

2017

Secondary 4

Geography

1.	Chung Cheng high School	SA1
2.	Crescent Girls' School	SA1
3.	Edgefield Secondary	SA1
4.	Ahmad Ibrahim Secondary	SA2
5.	Anglican High School	SA2
6.	Anglo Chinese School (Barker Road)	SA2
7.	Anglo Chinese School (Independent)	SA2
8.	Bedok View Secondary	SA2
9.	Fairfield Methodist School	SA2
10.	Geylang Methodist School	SA2
11.	Maris Stella High School	SA2
12.	St. Hilda's Secondary	SA2
13.	St. Joseph's Institution	SA2
14.	Temasek Secondary	SA2

Name:	Class	Class Register Number/ Centre No./Index No.
-------	-------	--



中正中学

CHUNG CHENG HIGH SCHOOL (MAIN)

Chung Cheng High School Chung Cheng High School Chung Cheng High School Chung Cheng High School Chung Cheng High School
 Chung Cheng High School Chung Cheng High School Chung Cheng High School Chung Cheng High School Chung Cheng High School
 Chung Cheng High School Chung Cheng High School Chung Cheng High School Chung Cheng High School Chung Cheng High School
 Chung Cheng High School Chung Cheng High School Chung Cheng High School Chung Cheng High School Chung Cheng High School
 Chung Cheng High School Chung Cheng High School Chung Cheng High School Chung Cheng High School Chung Cheng High School

MID-YEAR EXAMINATION 2017 SECONDARY 4

Geography

2236

Paper 1

Thursday 11 May 2017

1 hour 40 min

READ THESE INSTRUCTIONS FIRST

Do not open this booklet until you are told to do so.

Write your name, class and index number clearly in the spaces provided at the top of this page.

Write in dark blue or black pen on both sides of the paper.

You may use a pencil for any diagrams, graphs or rough working.

Do not use highlighters or correction fluid.

Section A

Answer Question 1

Section B

Answer one question.

Write all answers on the Answer Booklets provided.

Candidates should support their answers with the use of relevant examples.

Sketch maps and diagrams should be drawn wherever they serve to illustrate an answer.

At the end of the examination, submit Sections A and B separately.

The number of marks is given in brackets [] at the end of each question or part question.

This document consists of 10 printed pages.

[Turn over]

Section A**This question is compulsory.**

1. Some students were investigating two local beaches made up of different materials. The beaches were about 5 km apart in a popular tourist area. The beaches are shown in Fig. 1 on Page 3. They decided to test the following hypotheses:

Hypothesis 1: *The size of beach material increases away from the low water mark.*

Hypothesis 2: *The environmental impact of tourism varies between the two beaches.*

- a. To investigate Hypothesis 1, the students used a tape measure to plot a transect line from the edge of the sea at the low water mark to the top of each beach. They then used a quadrat to systematically sample the beach material at points along the transect line of each beach.
- i. Describe how data was collected using a quadrat. [4]
 - ii. What is systematic sampling? [1]
 - iii. Give two advantages of using systematic sampling. [2]

Fig. 1 for Question 1

Sketch map of beaches

Not to scale

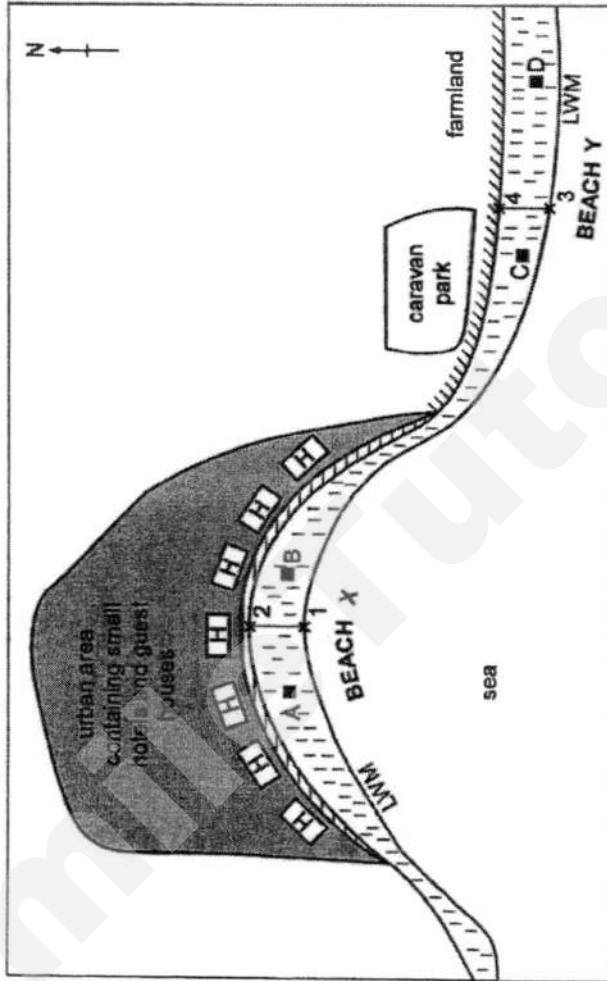

- Key
- large house
 - urban area
 - sea
 - cliff
 - beach
 - LWM
 - x1
 - x2
 - A

- b. The results of the investigation at selected sites are shown in Table 1, below.

Results of beach material investigation at selected sites

	Beach material (%)		
	Sand	Shingle	Pebbles
Site 1 – Beach X	90	10	0
Site 2 – Beach X	95	5	0
Site 3 – Beach Y	75	20	5
Site 4 – Beach Y	0	50	50

Table 1

- i. Complete the pie graph for site 3 at beach Y in Fig. 2 in Answer Booklet. [2]
- ii. Describe how proportions of the three materials (Sand, Shingle, Pebbles) differ between beaches X and Y. [3]
- iii. For which beach is **Hypothesis 1**: *The size of beach material increases away from the low water mark true?*
Support your conclusion with data from Table 1 and Fig. 2. [3]

- c. To investigate **Hypothesis 2**: *The environmental impact of tourism varies between the two beaches*, the students produced a bipolar scoring index which they used to survey the amount of litter on the beaches at four different sites (A, B, C and D), shown in Fig. 1. Fig. 3 shows their bipolar scoring sheet.

Scoring system for the survey of the impacts of tourism

Site:	-2	-1	0	1	2	
Lots of glass						No glass
Lots of paper						No paper
Lots of wood						No wood
Lots of plastic						No plastic
Lots of other litter (eg cigarette ends, food)						No other litter

Fig. 3

The results of the survey of the impacts of tourism are shown on Fig. 4.

Results of the survey of the Impacts of tourism

	Beach X		Beach Y	
	Site A	Site B	Site C	Site D
Glass	1	2	-1	0
Paper	1	2	-2	0
Wood	2	2	-1	-1
Plastic	2	2	-2	1
Other litter	1	2	-2	0
Total score	7	10	-8	0

Fig. 4

- i. Complete Fig. 5, in the Answer Booklet, by plotting the results for plastic at sites C and D. [2]

- ii. Do the results of the bipolar litter survey in Figs 4 and 5 support **Hypothesis 2: *The environmental impact of tourism varies between the two beaches?*** Explain your conclusion. [3]
- d. Suggest another hypothesis that the students could have investigated to compare the **natural** features of the two areas of coast they studied. Describe how they could investigate the hypothesis you have chosen. [5]

Section B
Answer one question from this section

- 2a. The Bahamas are a group of islands in the Atlantic Ocean where coral reefs have developed. Figs. 2A and 2B show the largest island, Andros Island, and the location of the nearby coral reefs.

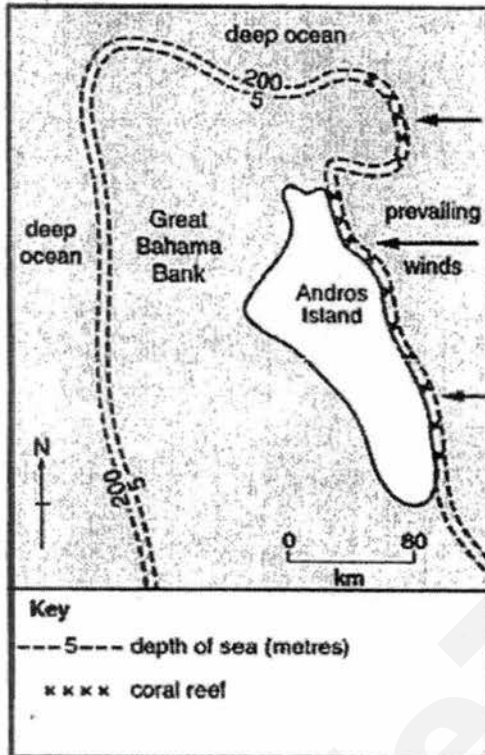

Fig. 2A

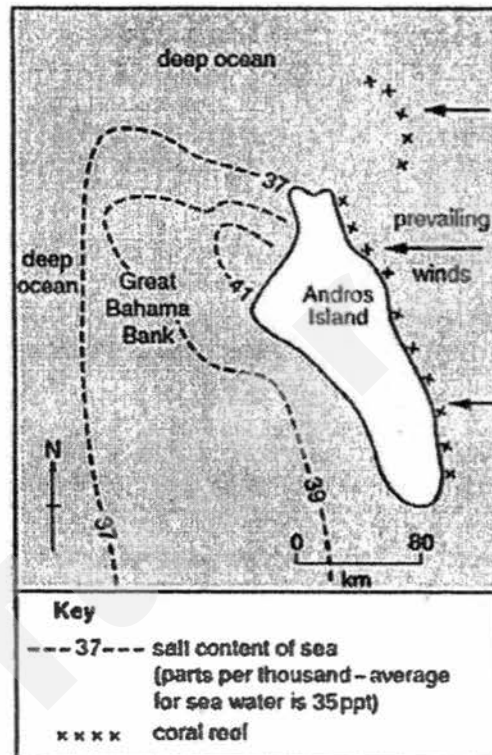
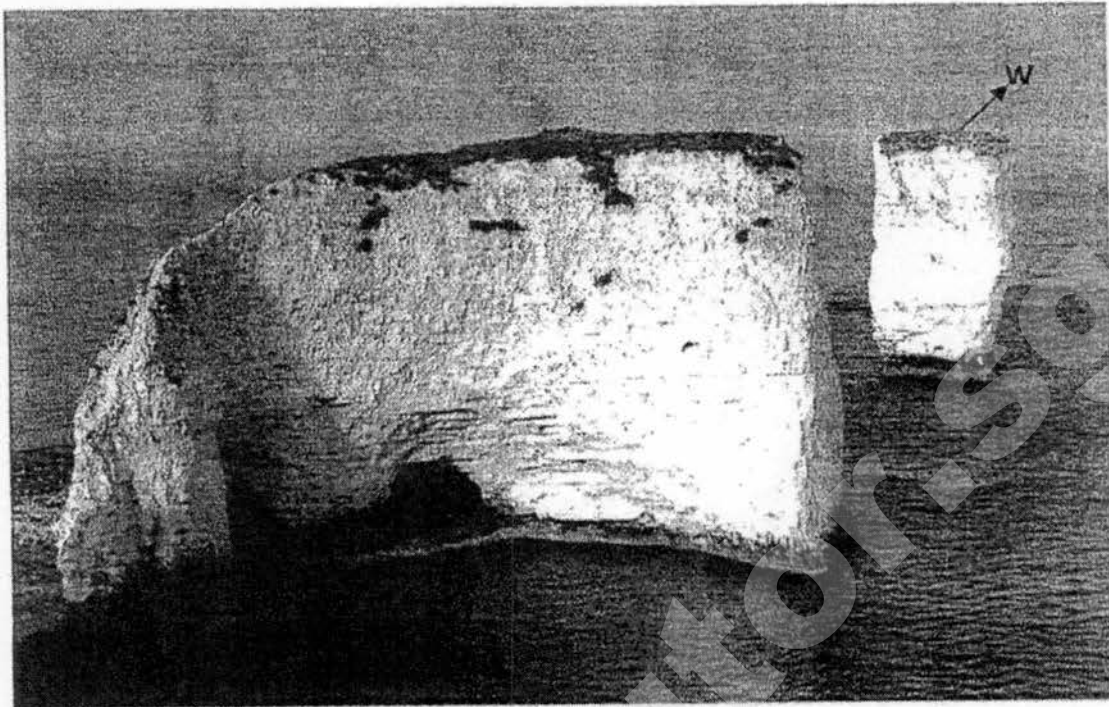

Fig. 2B

Using information from Figs. 2A and 2B, describe where the coral reefs are found and account for the location of these coral reefs. [6]

b. Study Photograph A, which shows a limestone coast.



Photograph A

With the help of well-labelled diagrams, explain the formation of coastal feature W. [6]

c. Explain why coastal erosion is much more rapid on some coasts than others. [5]

d. 'Investment in tourist destinations is the main reason for the growth of global tourism.'
How far do you agree with this statement? Support your answer using evidence. [8]

3a. Study Figs 3A and 3B, which show information about areas in Italy which attract tourists.

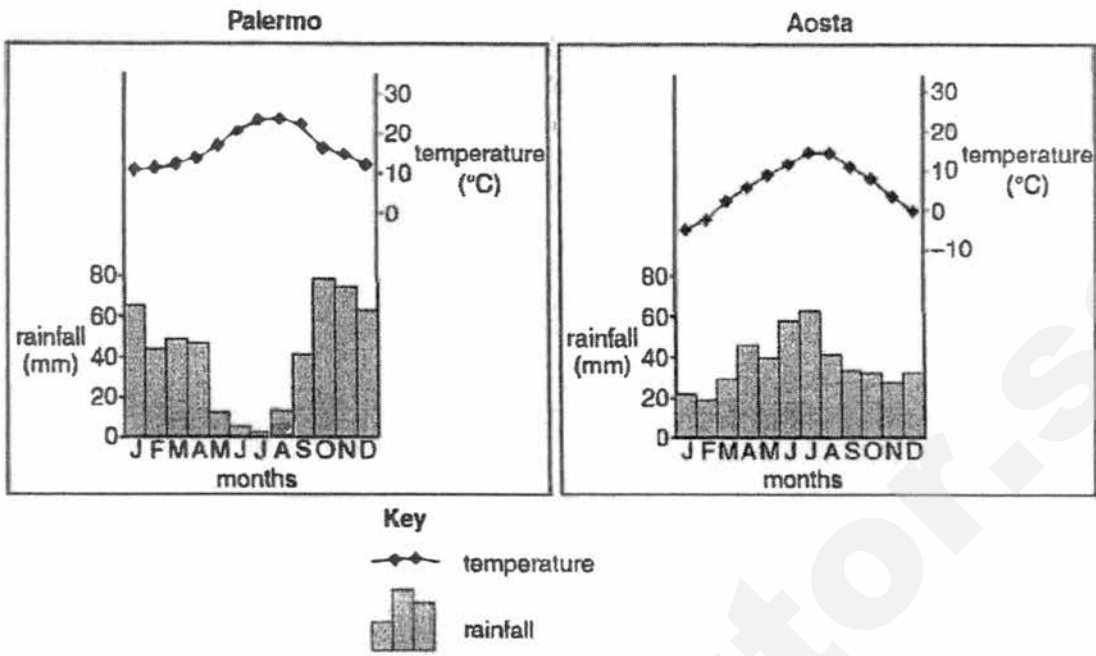

Figure 3A



Figure 3B

- i. Using only evidence from the climate graph for Palermo on Fig 3A, explain why it attracts large numbers of tourists between May and August. [3]
 - ii. Using Figs 3A and 3B only, suggest reasons why Aosta attracts tourists all year round. [4]
 - iii. Suggest how tourism may bring about possible benefits and problems for the locals. [5]
- b. Study Fig. 4, which shows newspaper headlines about the effects of tourism on an island in the Indian Ocean.

CORAL REEFS THREATENED BY TOURISM

PLANS ANNOUNCED TO RECLAIM COASTAL WETLANDS FOR RUNWAY EXTENSION TO INTERNATIONAL AIRPORT

100 ROOM RESORT AND CASINO TO OPEN IN SANDY BAY

Fig. 4

Based on Fig. 4, explain how tourism on the island could be developed in a sustainable way. [5]

- c. Using examples, evaluate the effectiveness of the role played by visitors and tour operators in developing sustainable tourism. [8]

END OF PAPER

Name:	Class:	Class Register Number:
-------	--------	------------------------



中正中学

CHUNG CHENG HIGH SCHOOL (MAIN)

Chung Cheng High School Chung Cheng High School Chung Cheng High School Chung Cheng High School Chung Cheng High School
 Chung Cheng High School Chung Cheng High School Chung Cheng High School Chung Cheng High School Chung Cheng High School
 Chung Cheng High School Chung Cheng High School Chung Cheng High School Chung Cheng High School Chung Cheng High School
 Chung Cheng High School Chung Cheng High School Chung Cheng High School Chung Cheng High School Chung Cheng High School

MID-YEAR EXAMINATION, 2017 SECONDARY FOUR

GEOGRAPHY

2236/02

Paper 2

3 May, Wednesday

1 hour 30 minutes

Additional
Materials:

Answer Booklets
Insert

READ THESE INSTRUCTIONS FIRST

Write your name, class and index number clearly in the spaces provided at the top of this page and on all answer booklets / writing paper used.

Write in dark blue or black pen.

You may use an HB pencil for any diagrams or graphs.

Do not use correction fluid.

Section A

Answer one question.

Section B

This question is **compulsory**.

Candidates should support answers with the use of relevant examples.

Sketch maps and diagrams should be drawn whenever they serve to illustrate an answer.

At the end of the examination, fasten all your work securely together.

The number of marks is given in brackets [] at the end of each question or part question.

This document consists of 6 printed pages.

Section A

Answer one question from this section.

- 1 (a) Fig. 1A and 1B show the climographs of Harbin and Shanghai respectively. Both cities are located in China and their geographical locations are shown in Fig. 1C (Insert).

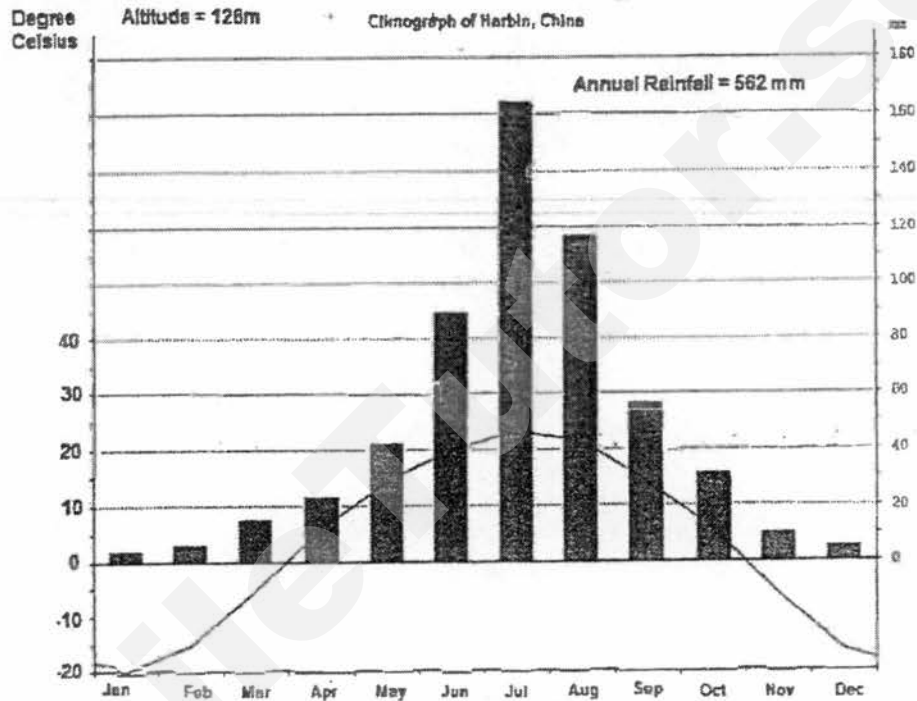

Fig. 1A

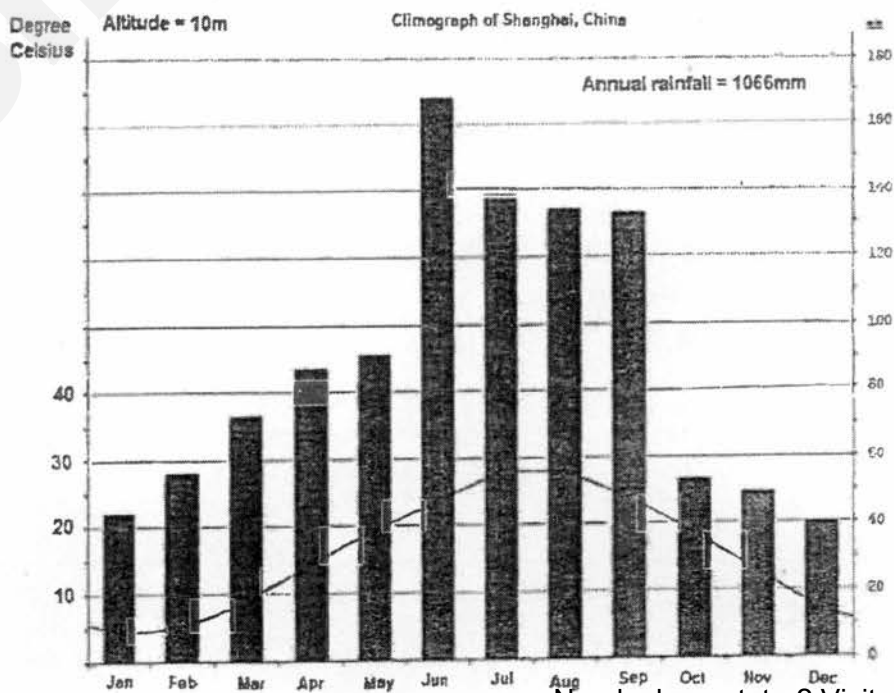

Fig. 1B

- (i) Compare the climatic conditions of Harbin and Shanghai. [3]
- (ii) Using information from Fig. 1A, 1B and Fig. 1C (Insert), explain the variation in the temperatures between Harbin and Shanghai. [6]
- (b) Fig. 2 shows the concentration of carbon dioxide (CO₂) and the average annual surface temperature of the Earth.

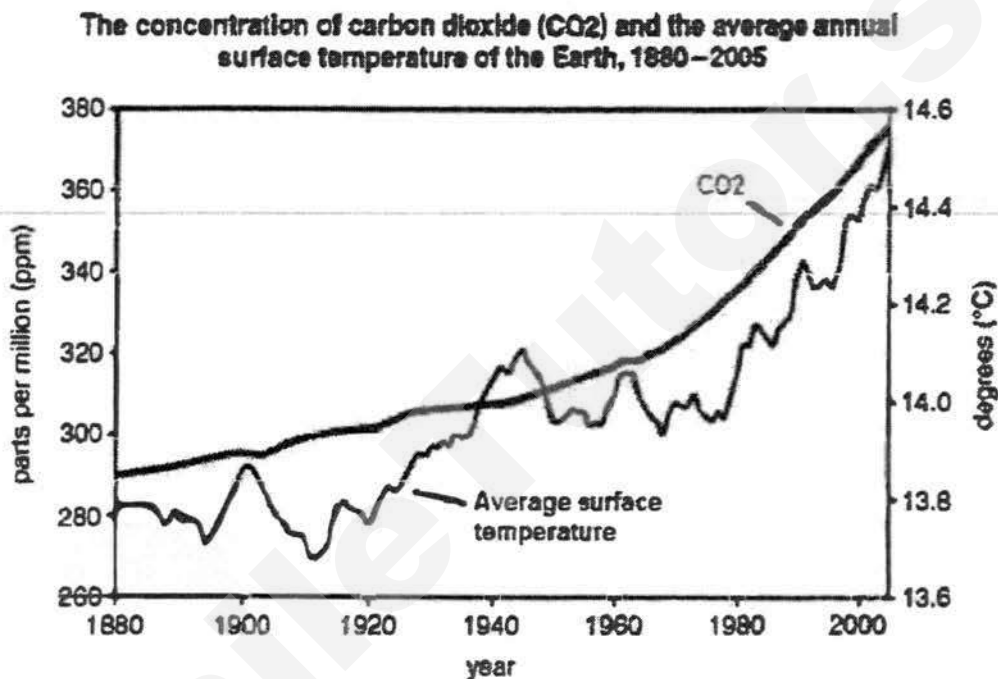

Fig. 2

Describe and explain the impact of changes in the concentration of carbon dioxide on the average annual surface temperature of the Earth from 1970 to 2000. [4]

(c) How does climate change affect people? [4]

(d) 'Human activities are a greater influence on climate change than natural causes.' To what extent do you consider this statement to be true? Give reasons to support your answer. [8]

- 2 (a) Fig. 3 (Insert) shows the hazards associated with the 1985 eruption of Nevado del Ruiz volcano in Columbia.

Describe the extent of the ash fall when the volcano erupted and explain possible risks caused by the eruption. [6]

- (b) Fig. 4 shows the location of some stratovolcanoes found in Columbia.

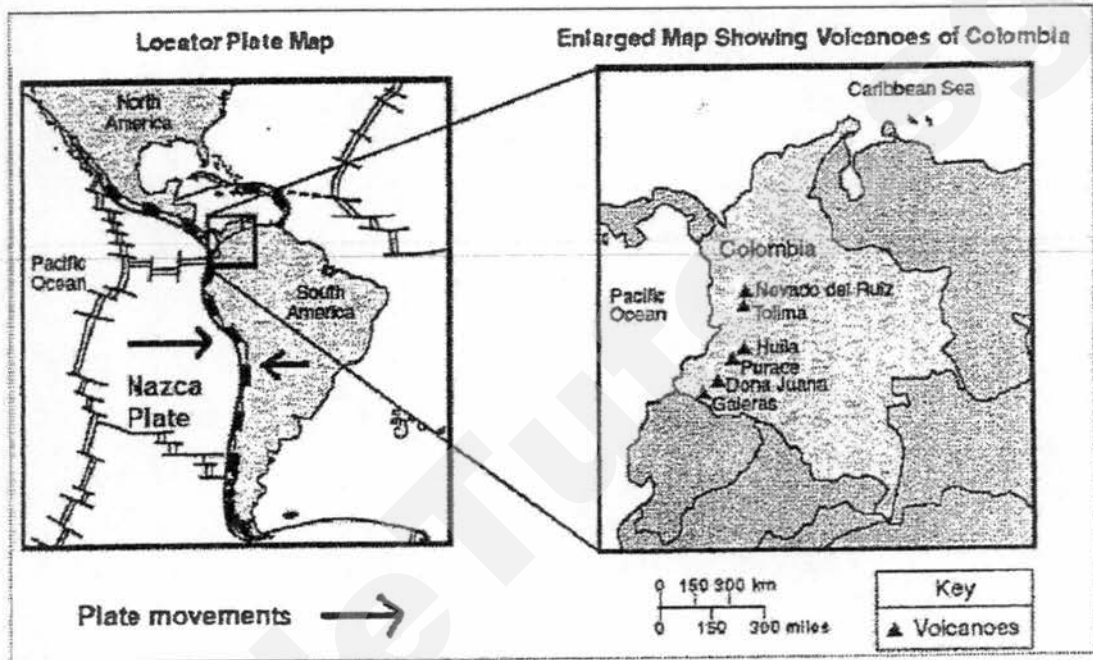

Fig. 4

- (i) With the use of a well-labelled diagram, illustrate the structure of a stratovolcano. [3]
- (ii) With reference to Fig. 4, explain why volcanoes are found along western Columbia. [4]
- (c) Describe the characteristics of tropical cyclones. [4]
- (d) 'The economic impacts of tropical cyclones are more difficult to overcome than the social impacts, when coping with the hazards brought about by the cyclones.'

How far do you agree with this statement? Give evidence to support your answer. [8]

Section B

This question is compulsory.

3.

- (ii) Using examples, explain the health and social problems faced by people living in areas where the population growth is greater than the increase in food production. [4]

(a) Fig. 6 shows meat consumption of China and Europe from 1961 to 2009.

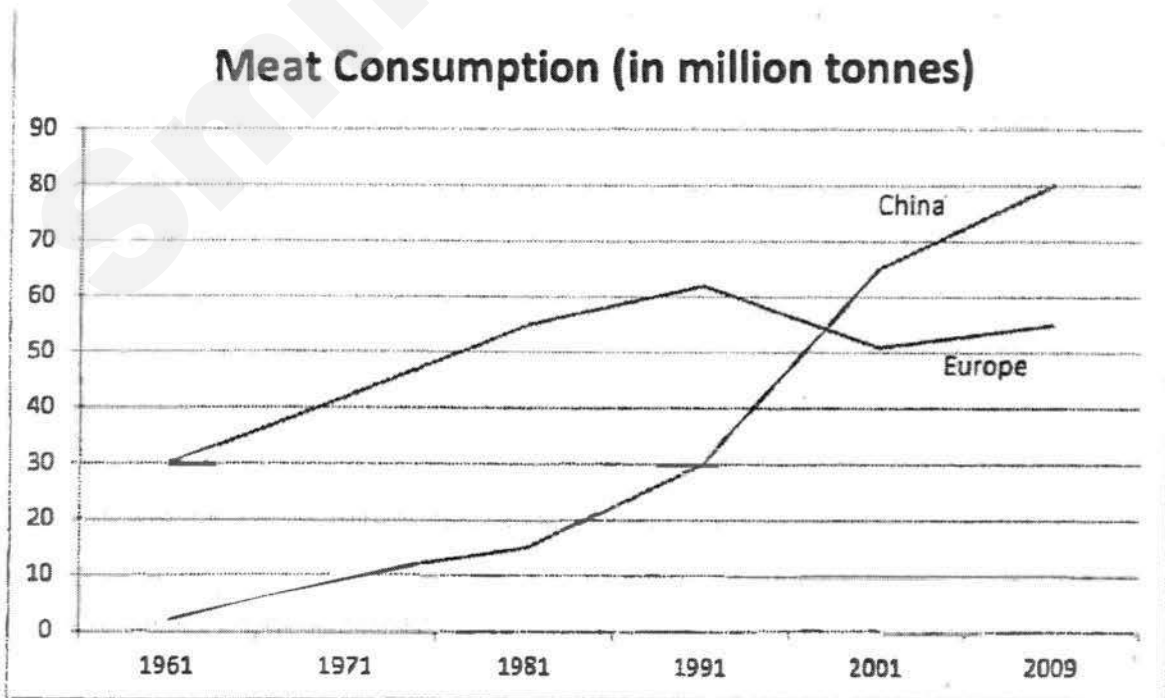

Fig. 6

Describe and account for the variation in changing consumption of meat between China and Europe from 1961 to 2009. [4]

(b) Explain the social and economic factors which result in food shortage in LDCs. [5]

(c) 'The use of biotechnology has been effective in overcoming food shortage.' How far do you agree? Give evidence to support your answer. [8]

-End of Paper-

SmileTutor.sg

Name:	Class	Class Register Number/ Centre No./Index No.
-------	-------	--



中正中學

CHUNG CHENG HIGH SCHOOL (MAIN)

Chung Cheng High School Chung Cheng High School Chung Cheng High School Chung Cheng High School Chung Cheng High School
 Chung Cheng High School Chung Cheng High School Chung Cheng High School Chung Cheng High School Chung Cheng High School
 Chung Cheng High School Chung Cheng High School Chung Cheng High School Chung Cheng High School Chung Cheng High School
 Chung Cheng High School Chung Cheng High School Chung Cheng High School Chung Cheng High School Chung Cheng High School

MID-YEAR EXAMINATION 2017 SECONDARY 4

Geography

2236

Paper 1

1 hour 40 min

**Section A
Question 1**

ANSWER BOOKLET

Please complete your answers for Question 1 in this booklet.

Section A Question 1	
Section B Question 2 / 3	
TOTAL	

Parent's signature: _____

Question 1

(b) (i)

Site 1 – Beach X at low water mark

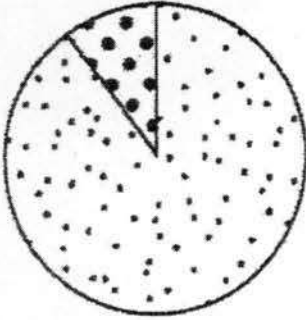

Site 2 – Beach X at the sea wall

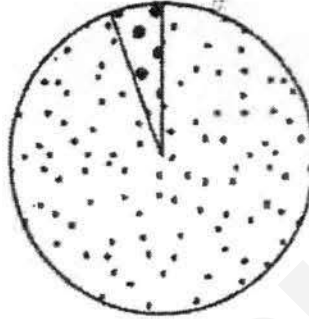

Site 3 – Beach Y at low water mark

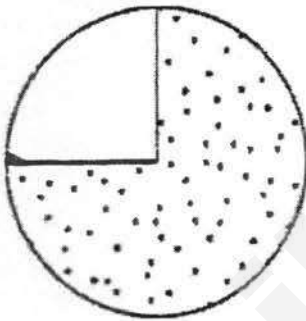

Site 4 – Beach Y at the foot of the cliff

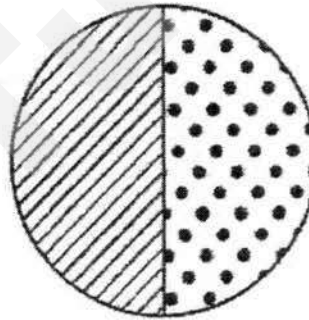

Key



sand



shingle



pebbles

Fig. 2

(c) (i)

Results of the survey of the impact of tourism

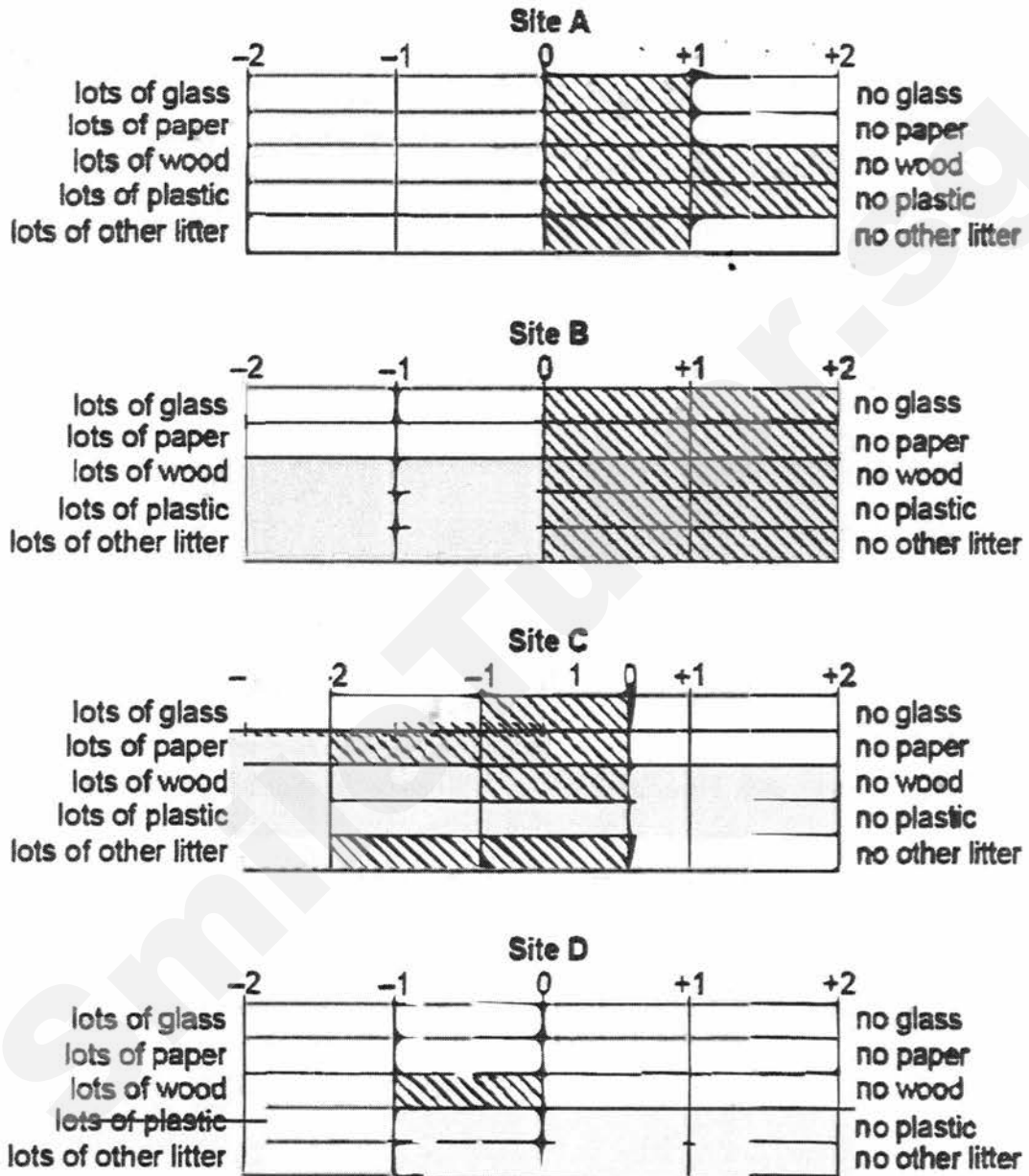

Fig. 5

Sec 4 Geog Mid-Year Examination Paper 1 2017

Suggested Answers

Section A

This question is compulsory.

1. Some students were investigating two local beaches made up of different materials. The beaches were about 5 km apart in a popular tourist area. The beaches are shown in Fig. 1 (Insert).

They decided to test the following hypotheses:

Hypothesis 1: *The size of beach material increases away from the low water mark.*

Hypothesis 2: *The environmental impact of tourism varies between the two beaches.*

- b. To investigate Hypothesis 1, the students used a tape measure to plot a transect line from the edge of the sea at the low water mark to the top of each beach. They then used a quadrat to systematically sample the beach material at points along the transect line of each beach.

- i. Describe how data was collected using a quadrat. [4]

- Quadrat was placed along the transect
- Sample of about 10 to 15 pebbles of beach material were measured
- along the long axis with a ruler or callipers
- location of beach material within quadrat chosen using random number tables

- ii. What is systematic sampling? [1]

- **Taking samples at equal distances / regular intervals / specific order**

- iii. Give two advantages of using systematic sampling. [2]

- **More efficient / Easier because sampling sites are evenly spaced out**
- **Fairer test / less bias than random**

- c. The results of the investigation at selected sites are shown in Table 1, below.

- (i) Complete the pie graph for site 3 at beach Y in Fig. 2 (Insert) in Answer Booklet. [2]

1 mark for dividing line – should be 72 / 18 degrees; allow +/- degree tolerance
1 mark for shading both slices correctly.

- (ii) Describe how proportions of the three materials (Sand, Shingle, Pebbles) differ between beaches X and Y. [3]

Sand:

- **higher proportion / percentage at beach X / Site 1 or 2 mainly sand at both sites on beach X but only at one site on beach Y**

- 90% (Site 1) or 95% (Site 2) as compared to 75% (Site 3) or 0% (Site 4)

Shingle:

- higher proportion / percentage at beach Y / Site 3 or 4 than 1 or 2 at X.
- 20% (Site 3) or 50% (Site 4) compared to 10% (Site 1) or 5% (Site 2).

Pebbles:

- no pebbles at beach X / Site 1 or 2 only pebbles at beach Y / Site 3 or 4
- 5% (Site 3) or 50% (Site 4) compared to 0% for Site 1 or Site 2

- (iii) For which beach is Hypothesis 1: The size of beach material increases away from the low water mark true?

Support your conclusion with data from Table 1 and Fig. 2.

[3]

Hypothesis is true for beach Y (1m)

Recognition that Site 3 is at LWM or site 4 is near cliff / further from LWM

- Sand decreases from 75–0% from Site 3 to 4/ by 75%
- Shingle increases from 20–50% from Site 3 to 4/ by 30%
- Pebbles increase from 5–50% from Site 3 to 4/ by 45%

[Any 2 supporting data; 1 mark each]

- (c) To investigate Hypothesis 2: The environmental impact of tourism varies between the two beaches the students produced a bipolar scoring index which they used to survey the amount of litter on the beaches at four different sites (A, B, C and D), shown in Fig. 1

Fig. 3 shows their bipolar scoring sheet.

The results of the survey of the impacts of tourism are shown on Fig. 4

- (i) Complete Fig. 5, in the Answer Booklet, by plotting the results for plastic at sites C and D. [2]

1 mark each for shading accurate bars at -2 on C and +1 on D for plastic

- (ii) Do the results of the bipolar litter survey in Figs 4 and 5 support Hypothesis 2: The environmental impact of tourism varies between the two beaches? Explain your conclusion. [3]

Yes / hypothesis is true

- Positive or no negative impact at beach X / mostly negative impact at beach Y
- Beach X / Sites A and B cleaner or less litter than Beach Y / Sites C and D (Total scores: 7 (Site 1), 10 (Site 2) compared to -8 (Site 3), 0 (Site 4).)

If disagree / partially agree no marks at all.

If no decision made, mark correct explanation for 1 max.

- d. Suggest another hypothesis that the students could have investigated to compare the natural features of the two areas of coast they studied. Describe how they could investigate the hypothesis you have chosen. [5]

Hypothesis (1 mark)

Can be phrased as a statement or question.

- *Constructive / destructive waves affect the beach X and Y differently.*
- *The beach profile varies between X and Y.*
- *Longshore drift affects the size of beach material at the beaches at X and Y*
- *The direction of sediment movement is influenced by wind direction (Investigate This 3: Pg 17)*
- *Wave frequency is more frequent at Beach Y*

Look for four logical sequential investigative methods

To avoid double penalising, if the hypothesis is not acceptable, award up to max. of 2 marks for HOW they would carry out their investigation.

Example: Beach profiles:

Mark the line of transect

Measuring pole stuck into beach of water's edge.

Measure 10m up the beach and stick other measuring pole into sand.

Use clinometer to measure angle between to poles.

Record the angle and repeat along the transect line

Repeat for other transect lines

2a. The Bahamas are a group of islands in the Atlantic Ocean where coral reefs have developed. Figs. 2A and 2B show the largest island, Andros Island, and the location of the nearby coral reefs.

Using information from Figs. 2A and 2B, describe where the coral reefs are found and account for the location of these coral reefs. [6]

- The corals are found between 5 and 200 m depth,
- As they require sunlight for the algae to photosynthesise
- Corals are also found in areas where salinity is between 35ppt to 37ppt (cannot be 35 or 37)
- Which is average since coral needs average salinity
- Corals are found on eastern coast of the island/windward/windy side/side of prevailing wind,
- As they require strong waves to provide oxygen and food supplies / to prevent sediments from suffocating living corals

2b. Study Photograph A, which shows a limestone coast.

With the help of well-labelled diagrams, explain the formation of coastal feature W. [6]

- Waves attack lines of weakness (joints and faults at the base of the headland/ undercut it.
- Continuous action / Further erosion of waves forms a cave. Caves may develop on each side of the headland. Erosion may eventually join caves together.
- Leaving a bridge of rock known as an arch above the opening.
- Top of the arch may collapse to form a stack.

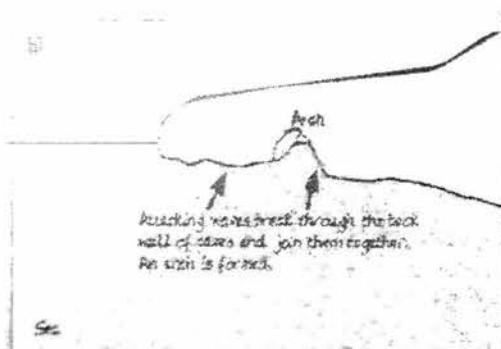

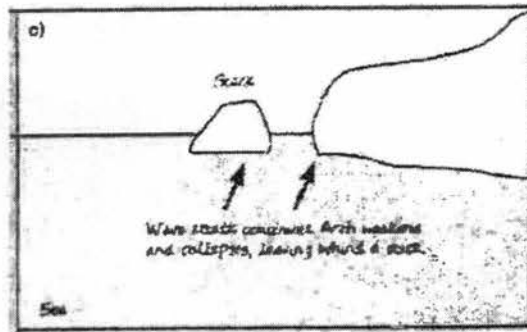

Note: Diagram – 2m (1m for diagram, 1m for labelling – details must be given)

2c. Explain why coastal erosion is much more rapid on some coasts than others. [5]

- Coastal erosion is more rapid when there are lines of weakness. These joints/ lines of weakness will make the rocks weaker and erosion can occur along these lines.
- Rock composition determines the hardness of rocks and their resistance to erosion, which affects the rate of erosion along coasts. More resistant rocks such as granite and basalt will erode slower than less resistant rocks such as limestone and shale.
- Coastal erosion is more rapid when the wave energy is high which is of destructive waves. The backwash is stronger than swash which erodes the coasts faster.
- Coastal erosion is more rapid on coasts which are unsheltered and hence the distance of the fetch is long. This will create high wave energy compared to coasts with shorter fetch.
- Coastal erosion is more rapid on coasts without coastal defences compared to coasts with coastal defences.

c. 'Investment in tourist destinations is the main reason for the growth of global tourism.' How far do you agree with this statement? Support your answer using evidence. [8]

I agree that investment in tourist destinations does help support the growth of global tourism. Destination factors such as building attractions, investment in infrastructure and services and access to information have helped in the growth. Places with more attractions will attract a larger number of tourists. Natural attractions as well as built attractions, such as medical services, theme parks etc, offer something unique and interesting to international tourists. For example, Dubai, has become a major destination and stopover location between Europe and Asia. It has a wide range of retail and luxury outlets. Two of Dubai's most well-known built attractions are: The Burj Al Arab, a 'seven-star' luxury hotel built on an artificial island; and the Palm Islands, the world's largest artificial islands for high-end residential, leisure and entertainment facilities. Hence investment in attractions will help to boost tourism growth as they attract more tourists.

Investment in infrastructure and services also help drive the growth of global tourism. Transportation infrastructure such as airport expansion and development; as well as road and railway links is crucial to help facilitate tourist movement. For example, Singapore's Changi Airport and Bangkok's Suvarnabhumi Airport have undergone considerable expansion to facilitate increased international tourist arrivals. Another type of infrastructure is accommodation. Sufficient hotels must be built to receive the rising number of tourists. Therefore, investment into infrastructure and services will help to increase the country's capacity to cater to higher tourist numbers.

However, there are also other reasons for the growth of tourism. Although the destination's infrastructure and attractions may be built, other reasons such as development in technology as well as demand factors arising from changing profile of tourists will also affect the growth of tourism. Demand factors which include disposable income, leisure time and changing lifestyle all play a part in determining people's ability to travel. With increasing disposable income, people are more willing to spend on activities that improve their quality of life. One such activity is travelling. Countries such as India and China have experienced rapid economic growth hence the number of travellers from the middle and high income groups has been growing.

This shows that other factors aside from investment alone, can also help to push tourism growth.

Level 1 (0 – 3)

At this level answers will be generalized or with minimal support if any given at all. Reasoning is rather weak and expression may be unclear. A basic answer that has little development. Answers lack examples or other evidence, or it is so sketchy that it adds little support to the answer.

Level 2 (4 – 6)

Disagreement or agreement will be supported by appropriate detail. Or, both agreement and disagreement are considered, but support is patchy so that the answer is not full. Good reasoning and logic in parts of the answer with good expression in places. Some examples or other evidence will be presented to support answers in at least one place in the answer.

Level 3 (7 – 8)

At this level answers will be comprehensive and supported by sound knowledge. Both agreement and disagreement are considered and well supported. Reasoning is clear and logical with good expression of language. Examples or other evidence to support answers will be extensive.

3a. Study Figs 3A and 3B, which show information about areas in Italy which attract tourists.

i. Using only evidence from the climate graph for Palermo on Fig 3A, explain why it attracts large numbers of tourists between May and August. [3]

- **Attractive to tourists as they can enjoy many activities with the warm temperatures and low rainfall**
- **High Temperatures from May to August range from 15°C to 25°C**
- **Low Rainfall between 5 to 15mm each month**

ii. Using Figs 3A and 3B only, suggest reasons why Aosta attracts tourists all year round. [4]

- **From Dec to Feb, it is winter season as the temperatures are below zero. There is likely to be snow where people can go skiing/ enjoy winter sports**
- **From Feb to Nov, the temperatures are mild with highest temperature at 15°C. People can have many activities such as walking, hiking, camping etc as conditions are comfortable**
- **Except for the months of June and July, rainfall is not very high at below 60mm per month**
- **Aosta is also attractive as there are mountains where people may want to visit for the scenery**

iii. Suggest how tourism may bring about possible benefits and problems for the locals. [5]

Benefits

- **Income**

The growth in tourism can bring about an increase in the number of tourism-related jobs which can provide the locals with employment. This can help locals earn income which can improve their standard of living.

- **Infrastructure development**

Roads that link airports, cities and tourist sites allow tourists access to local attractions. They also allow local people better access to more markets, health care, education and jobs.

- **Employment opportunities**

Tourism also brings about employment for local workers. Individuals involved in tourism related jobs can earn more income which can better their lives.

Problems

- **Shortage of services**

Tourist infrastructure may require the use of large amounts of land, water and power. This could lead to a shortage of services such as water supplies or power in non-tourist areas. Locals can suffer from a shortage of power or water when they cannot afford to pay as much as the tourists.

- **Increased congestion**

Large numbers of tourists can cause overcrowding in areas close to popular attractions. Due to the large crowd, tourist shops and accommodations can cluster near such areas and make them even more congested. This often causes vehicular

and pedestrian traffic to become congested which can disrupt the lives of the locals. The huge inflow of cars and buses can also contribute to air pollution which may affect the health of the locals

Note that answers must show how the locals are affected, the link must be explicit.

b. Study Fig. 2, which shows newspaper headlines about the effects of tourism on an island in the Indian Ocean.

Based on Fig. 2, explain how tourism on the island could be developed in a sustainable way. [5]

- There could be restrictions to the number of tourists to the coral reef. This will reduce the impact and pressure to the coral reefs.
 - Laws and regulations can be made to control/ stop people from fishing on the reef/ diving/ anchoring.
 - The authorities could ensure that areas are set aside to conserve wildlife. These protected areas eg coastal wetlands should not be cleared from tourism development.
 - The planning authorities could encourage ecotourism. Instead with the protected areas. This will help to educate the tourists on the importance of protecting the environment while they are visiting the areas.
 - There could be restrictions to sensitive areas eg coral reef to ensure that the environment is not destroyed
 - The authorities could also employ locals and use local materials for the building of the resort and casino to develop tourism in a sustainable way that also benefits locals.
- d. Using examples, evaluate the effectiveness of the role played by visitors and tour operators in developing sustainable tourism. [8]

Visitors play an important role in developing sustainable tourism as they can be respectful of the environment and the local people of the place that they are visiting. They should visit without causing damage or offence. For example, in a report in 2007, the Tourism Sustainability Group, set up by the European Commission in 2004, encouraged tourists to select their holiday destinations based on the conservation efforts of the place. This is because tourists want to minimize their carbon footprint while they are on holiday. They may thus consider factors such as the amount of water used and the amount of waste recycled at these destinations. This helps to promote sustainable tourism as visitors' demand will change the way tourism is organised.

Visitor spending can also provide funds to help conserve environment, preserve culture or maintain a tourist attraction. Such visitor spending can include entrance fees or the purchase of souvenirs can be used to conserve a tourist site. Visitor spending can also provide locals with income from employment and businesses. Visitors usually require hotel workers, hotel staff, waitresses and tour guides, which are employment positions that locals can easily fill. The arrival of tourists also gives locals opportunities to set up businesses such as tour companies or shops. Visitors to a destination may realise

the value of conserving and preserving the destination. These visitors also raise awareness about the destination at home by sharing their experiences via word-of-mouth. In turn their visits become more rewarding with the knowledge that they have done their best to avoid damaging these environments.

However, visitors may exhibit behaviours that can damage a tourist attraction. Examples of these behaviours are vandalism and littering. In some cases, the sheer number of tourists alone can damage a tourist site through their collective footsteps, noise or touch.

Large numbers of visitors can also cause a place to lose its identity, such as when dancers deliberately pose for tourists to take photographs. As a result, visitors may complain that a place or performance does not feel 'authentic'. The dilution of local culture becomes more pronounced whenever visitors outnumber locals in an area and commercial activities focus mainly on tourism.

Visitors spend much of their time in a tourist attraction with tour guides or other staff of a tour operator. Therefore, tour operators are often in the best position to regulate tourist behavior. This includes preventing tourists from littering, from vandering into restricted areas or from making too much noise to prevent damage to tourist site. For example, a group known as Phuket Alternative Tours (PAT) which was set up by the team of tour operators in Phuket in 2006. Tour operators who want to operate under PAT are required to sign an Environmental and Cultural Code of Practice, which commits members to operate in an environmentally sustainable way, seek to enhance the natural environment and the way that the industry uses it, and to create awareness about environmental conservation for visitors to Phuket.

Tour guides can also offer valuable feedback to tour operators about the social and environmental conditions of a tourist attraction. Their inputs are often used by local communities and planning authorities to plan tourism management strategies in a tourist attraction. This can help tourism to be more sustainable as the needs of the communities are taken into consideration.

However, tour operators are businesses and need to be profitable to survive. The need to generate profits may override concerns to preserve the environment when addressing these concerns would reduce their profits.

Level 1 (0 – 3)

At this level answers will be generalized or with minimal support if any given at all. Reasoning is rather weak and expression may be unclear. A basic answer with little development. Answers lack examples or other evidence, or is so sketchy that it adds little support to the answer.

Level 2 (4 – 6)

Successful or unsuccessful aspects are supported by appropriate detail. Or, both successful and unsuccessful aspects are considered, but support is patchy so that the answer is not full. Good reasoning and logic in parts of the answer with good

expression in places. Some examples or other evidence will be presented to support answers in at least one place in the answer.

Level 3 (7 – 8)

At this level answers will be comprehensive and supported by sound knowledge.

Both successful and unsuccessful aspects are considered and well supported.

Reasoning is clear and logical with good expression of language. Examples or other evidence to support answers will be extensive.

SmileTutor.sg

Name:	Class:	Class Register Number:
-------	--------	------------------------



中正中學

CHUNG CHENG HIGH SCHOOL (MAIN)

Chung Cheng High School Chung Cheng High School Chung Cheng High School Chung Cheng High School Chung Cheng High School
 Chung Cheng High School Chung Cheng High School Chung Cheng High School Chung Cheng High School Chung Cheng High School
 Chung Cheng High School Chung Cheng High School Chung Cheng High School Chung Cheng High School Chung Cheng High School
 Chung Cheng High School Chung Cheng High School Chung Cheng High School Chung Cheng High School Chung Cheng High School
 Chung Cheng High School Chung Cheng High School Chung Cheng High School Chung Cheng High School Chung Cheng High School

MID-YEAR EXAMINATION, 2017 SECONDARY FOUR

GEOGRAPHY

2236/02

Paper 2

3 May, Wednesday

1 hour 30 minutes

Additional
Materials:

Answer Booklets
Insert

READ THESE INSTRUCTIONS FIRST

Write your name, class and index number clearly in the spaces provided at the top of this page and on all answer booklets / writing paper used.

Write in dark blue or black pen.

You may use an HB pencil for any diagrams or graphs.

Do not use correction fluid.

Section A

Answer one question.

Section B

This question is compulsory.

Candidates should support answers with the use of relevant examples.

Sketch maps and diagrams should be drawn whenever they serve to illustrate an answer.

At the end of the examination, fasten all your work securely together.

The number of marks is given in brackets [] at the end of each question or part question.

This document consists of 16 printed pages.

Sec 4 Geography Mid-Year Examination Paper 2

Suggested Answers

Section A

Answer one question from this section.

- 1 (a) Fig. 1A and 1B show the climographs of Harbin and Shanghai respectively. Both cities are located in China and their geographical locations are shown in Fig. 1C (Insert).

Compare the climatic conditions of Harbin and Shanghai. [3]

- Average annual temperature in Harbin is 1°C , which is lower than Shanghai's 16.5°C .
- Annual temperature range in Harbin is 42°C , which is larger than Shanghai's 22°C .
- Annual precipitation in Harbin is 562mm , which is lesser than Shanghai's 1066mm .

- (i) Using information from Fig. 1A, 1B and Fig. 1C (Insert), explain the variation in the temperatures between Harbin and Shanghai. [6]

- Harbin is located at higher latitudes than Shanghai and hence the solar angle is lower / sun rays strike at a lower angle
- and the solar energy is spread out over a wider area, resulting in a lower average temperature.
- Harbin is located at higher altitude of 126m , as compared to Shanghai, which is 10m . The higher the altitude, the further it is from the surface of the Earth which emits heat in the form of longwave radiation, hence resulting in lower average temperature.
- Air is also less dense at higher altitudes, which absorbs less heat from the longwave radiation from the earth's surface, resulting in lower average temperature.
- Harbin has a larger annual temperature range as it is located further inland and not influenced by the sea.
- During summer, the air over the land gains heat faster, leading to warmer summers and during winter, the air over the land loses heat faster, leading to colder winters.

[Factors to include are latitude, altitude and distance from the sea – each factor to award max of 2 marks]

- (b) Fig. 2 shows the concentration of carbon dioxide (CO₂) and the average annual surface temperature of the Earth.

Describe and explain the impact of changes in the concentration of carbon dioxide on the average annual surface temperature of the Earth from 1970 to 2000. [4]

- CO₂ has increased rapidly from about 325 to about 370 ppm, an increase of 45 ppm.
- This sharp increase had resulted in an overall sharp increase of average annual surface temperature of the Earth from about 14.0 to 14.5 °C, an increase of about 0.5°C
- CO₂ is a **greenhouse gas** which absorb longwave radiation and
- **more concentration of CO₂ results in more longwave radiation being absorbed**, leading to higher average annual surface temperature of the Earth

- (c) How does climate change affect people? [4]

- Climate change results in melting of glaciers in Greenland and Antarctica, which leads to rising sea level. **Rising sea levels** threaten low-lying areas and islands, resulting in **the loss of homes of people** living in these areas.
- Climate change results in **extreme weather events**, such as more intense tropical storms, flooding and heat waves, which may kill people and also result in significant **economic loss**.
- Climate change could result in increased temperatures and rainfall which encourages the breeding of mosquitoes. This may result in **higher incidences of insect-borne diseases** such as malaria to spread among people.
- Climate change may affect **the growing season of crops as some regions** may be able to grow more types of crops which require **higher temperatures**, but **some regions** may find it too warm to grow certain crops. Hence, **food supply may be affected**.

- (d) 'Human activities are a greater influence on climate change than natural causes.'
To what extent do you consider this statement to be true? Give reasons to support your answer. [8]

I consider this statement to be true to a large extent.

While natural causes will also influence climate change, these natural cycles of periods of warming and cooling, as seen in historical records, may not have as great an influence, compared to human activities. Climate change has been linked to natural causes such as volcanic eruptions and variations in solar output. Changes in magnetic field cause the sun to emit varying amounts of solar radiation. Increase in

magnetic activity results in an increase in solar radiation thus causing global temperatures to increase. The number of sunspots, which are cooler regions on the sun's surface, affect the amount of solar radiation emitted. More sunspots results in more solar radiation being emitted, thus causing increase in temperatures. For example, in 2000, a peak in the number of sunspots coincided with higher solar activity and also increases in global temperatures.

In a volcanic eruption, large volumes of carbon dioxide, water vapour, sulphur dioxide, dust and ash are released into the atmosphere. Together with dust and ash, these particles reflect solar energy back into space. This results in a cooling influence on regional and global temperatures. Eg The eruption of Mount Pinatubo in the Philippines in 1991 lower temperatures in the northern hemisphere by as much as 0.6°C.

While natural causes such as these do influence climate change, the impact is not large as the significance of the resultant increase or decrease is usually not long term. For instance, periods of global dimming which were caused by volcanic eruptions will only last for as long as the volcanic dust and ash remain in the atmosphere. Once the dust and ash settle, the global cooling affect will cause. In the case of the Mount Pinatubo eruption in 1991, the lowering of global temperatures lasted for only two years in some locations.

Human activities do have a greater influence on climate change as these activities lead to the enhanced greenhouse effect where global temperatures have been on the rise.

When forests are cleared for mining, farming or construction of infrastructure, fewer trees and plants will absorb carbon dioxide, leading to an increase in carbon dioxide levels. Deforestation also leads to increasing rate of carbon oxidation in the soil, hence increasing the amount of carbon dioxide released from the soil. Forests are cleared extensively in Amazon Forest, Brazil and many parts of Southeast Asia.

Burning of fossil fuels helps to produce energy for industries, particularly manufacturing, transportation as well as domestic and commercial activities. Greenhouse gases are also released as by products when goods are produced. Large consumers of fossil fuels include China and USA. Burning of fossil fuels produce large amounts of carbon dioxide, which contributes to the increase in amount of greenhouse gases in the atmosphere, thus causing more heat to be trapped. This eventually leads to global warming. For example, in 2010, global carbon dioxide emissions totalled 30.6 billion tonnes which is an increase by 5.6% from 2009.

The greenhouse gases emitted as a result of human activities will remain in the atmosphere for a long time. Hence the influence on climate change is longer term than the natural causes. Therefore I consider the statement to be largely true.

Level 1 (0 – 3)

At this level answers will be generalized or with minimal support if any stand were given at all. Reasoning is rather weak and expression may be unclear. A basic

answer that has little development. Answers lack examples or other evidence, or is so sketchy that it adds little support to the answer.

Level 2 (4 – 6)

Disagreement or agreement will be supported by appropriate detail. Or, both agreement and disagreement are considered, but support is patchy so that the answer is not full. Good reasoning and logic in parts of the answer with good expression in places. Some examples or other evidence will be presented to support answers in at least one place in the answer.

Level 3 (7 – 8)

At this level answers will be comprehensive and supported by sound knowledge. Both agreement and disagreement are considered and well supported. Reasoning is clear and logical with good expression of language. Examples or other evidence to support answers will be extensive.

Note: To get L3 – 7/8, there must be an attempt to weigh the influence difference human activities and natural causes on climate change

2(a) Fig. 3 (Insert) shows the hazards associated with the 1985 eruption of Nevado del Ruiz volcano in Columbia.

Describe the extent of the ash fall when the volcano erupted and explain possible risks caused by the eruption. [6]

- The ash fall is largely confined to the north-eastern region of the volcano [must have this pt]
- And stretches a distance of 58.5km to Mendez, which is furthest away from the volcano

[Description, 2 pts]

- Volcanic materials produced by volcanic eruptions include lava and pyroclasts that consists of ash, rock fragments and volcanic bombs. These volcanic materials can lead to **widespread damage of property**.
- The pyroclasts when mixed with glacial ice along its path may trigger lahars or mudflows which may kill people and bury properties.
- Inhaling the hot ash and gases such as carbon dioxide, sulphur dioxide, hydrogen and carbon monoxide can result in **serious injury or death**
- Landslides can occur due to the structural collapse of a volcanic cone during a volcanic eruption. Landslides may obstruct the flow of rivers causing floods blocking roads and buried villages and farmlands.

- Ash particles ejected during a volcanic eruption can disrupt human activities over large distances from the volcano. Thick plumes of ash may eventually settle on the ground and block sunlight, suffocate crops and reduce food production, hence affect food supply.
- Volcanic ash clouds may contain tiny abrasive glass, sand and rock which pose a serious danger to aircraft, hence air space may be closed after a major volcanic eruption.

[Possible risks, 4 pts]

(b) Fig. 4 shows the location of some stratovolcanoes found in Columbia.

- (i) With the use of a well-labelled diagram, illustrate the structure of a stratovolcano. [3]

Answer:

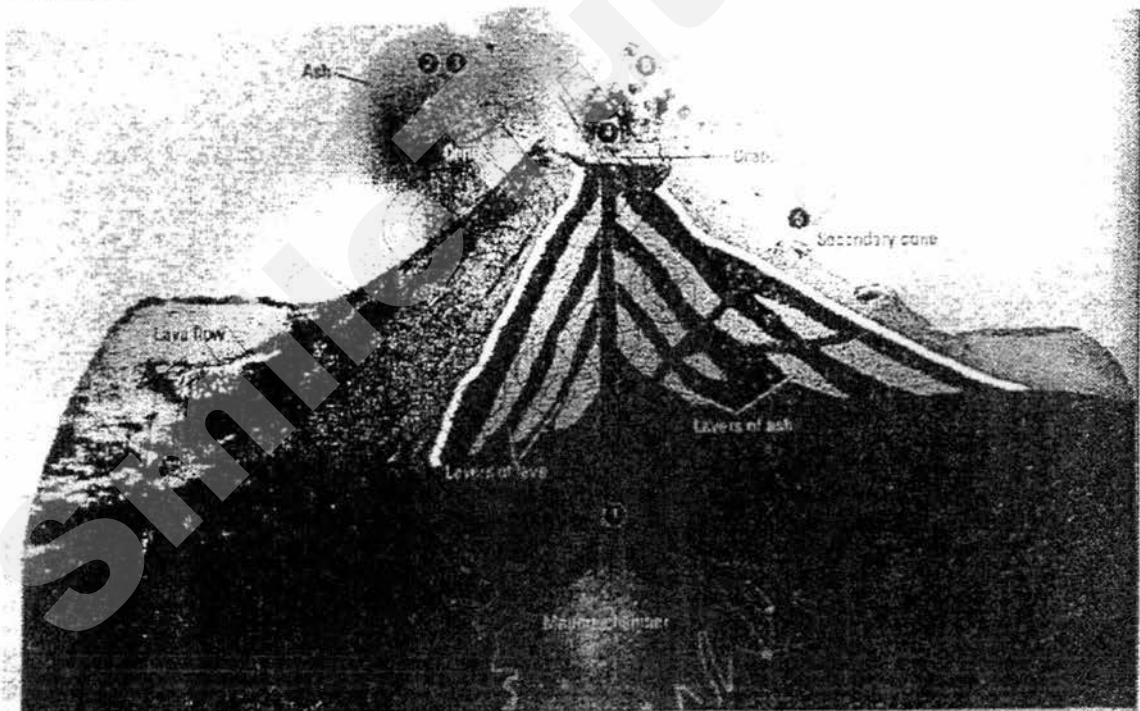

- Drawing of volcano – 1m (to show steeper at the top, gentler at the base)
- Key labels to be included – Vent, crater, secondary cone, layers or lava and ash – 2m (if any labels are missing, max of 1m)

- (ii) With reference to Fig. 4, explain why volcanoes are found along western Columbia. [4]

- When oceanic Nazca Plate converges with the continental South American Plate,
- the denser oceanic plate subducts under the less dense continental plate.

- At the same time, the **subducted ocean plate causes the mantle material above it to melt, forming magma**
- Melting of the subducting oceanic plate produces magma, which rises to the earth's surface through **fractures to form volcanoes.**

(c) Describe the characteristics of tropical cyclones. [4]

- Develop over the warm oceans in the tropics
- Range in diameter from 150 km to more than 1,500km
- Wind speeds of 119km per hour or more
- Steep pressure gradient
- Low central pressure
- Centre of the cyclone is calm and with no presence of clouds

[Any 4 points]

(d) 'The economic impacts of tropical cyclones are more difficult to overcome than the social impacts, when coping with the hazards brought about by the cyclones.'

How far do you agree with this statement? Give evidence to support your answer. [8]

I agree with the statement to a large extent.

Economic impacts of tropical cyclones include the costs of repairs of damaged property and infrastructure, and the loss of income due to damaged crops. These costs can amount to a large sum.

The damage to property and infrastructure caused by tropical cyclones can be expensive to repair. E.g the damage caused by Hurricane Katrina which struck the east coast of the USA in 2005, cost an estimated US\$81 billion. A large portion of the cost came from repairs of more than 200,000 homes.

Great economic costs are also incurred from damaged crops. When Tropical Cyclone Yasi hit North Queensland, Australia, in 2011, about 75% of the total banana crop amounting to US\$350 million was lost. Sugar cane farmers also suffered economic losses, as the tropical cyclone destroyed 20% of the total area of their farmland.

The economic costs for all countries affected by tropical cyclones amount to almost US\$26 billion annually. This amount is projected to increase to US\$55 billion by 2100 due to growing population in coastal areas. **Hence economic impacts of cyclones may be difficult to overcome as not all countries will have such large financial resources to restore damages caused by tropical cyclones.**

However, I disagree with the statement, as social impacts of cyclones may also be difficult to overcome.

Social impacts of tropical cyclones include disruption to the water supply, sanitation and hygiene facilities. Damage to water pipes and pumps may result in people not able to get fresh water.

Flooding caused by tropical cyclones may cause sewage from burst sewage pipes to flow into and contaminate existing water supplies. Consumption of the contaminated water leads to spread of water-borne diseases such as cholera and typhoid fever. In 2009, when Cyclone Aila hit West Bengal India, contaminated drinking water caused a cholera outbreak, resulting in about 1000 infected people and 14 deaths.

Flooding caused by a tropical cyclone may also result in the spread of diseases transmitted by insects. E.g cases of dengue fever and malaria increased in Guatemala and Nicaragua after Hurricane Mitch struck in 1998. In most of these cases, the large-scale flooding and the fast rate at which diseases spread make it difficult to provide adequate medical care.

People may be displaced from their homes and have to live in temporary shelters. E.g After Hurricane Katrina struck New Orleans, USA in 2005, Hundreds of thousands of people lost their homes and have to live in temporary shelters.

It may be difficult to overcome the social impacts of tropical cyclones such as the trauma of losing loved ones and being displaced from homes. It may be hard for victims of cyclones to remain resilient when their basic necessities such as food, clean water and sewage facilities are not met.

Economic impacts of tropical cyclones may be more difficult to overcome than the social impacts as without financial resources, countries which are affected will have difficulties in coping with the high cost involved in restoring damaged buildings and infrastructures. When these damages are not restored, the social impacts such as homelessness, lack of basic services such as water supply and sanitation, will be difficult to manage.

Level 1 (0 – 3)

At this level answers will be generalized or with minimal support if any stand were given at all. Reasoning is rather weak and expression may be unclear. A basic answer that has little development. Answers lack examples or other evidence, or is so sketchy that it adds little support to the answer.

Level 2 (4 – 6)

Disagreement or agreement will be supported by appropriate detail. Or, both agreement and disagreement are considered, but support is patchy so that the answer is not full. Good reasoning and logic in parts of the answer with good expression in places. Some examples or other evidence will be presented to support answers in at least one place in the answer.

Level 3 (7 – 8)

At this level answers will be comprehensive and supported by sound knowledge. Both agreement and disagreement are considered and well supported. Reasoning is clear and logical with good expression of language. Examples or other evidence to support answers will be extensive.

Section B

Answer this question

3. Fig. 5 shows information about food production in selected countries.

(a) (i) Describe the areas where annual population growth is greater than the increase in food production. [4]

- The areas where annual population growth is greater than the increase of food production is **mainly found within the Tropics.** [must have this point]
- Largest area where annual population growth is greater than the increase in food production is found in Africa. In northern Africa such as Mauritania, Algeria and Egypt
- In Sub-Saharan region, in countries such as Ghana, Senegal, Nigeria, Chad, Sudan, Eritrea, Ethiopia, South Sudan, Somalia, Cameroon, Congo, Democratic Republic of Congo, Angola, Zambia, Mozambique, Madagascar, Zimbabwe, Kenya
- Another area is found in Middle East region in countries such as Yemen and Iraq
- Another area is found in Central America, in countries like Nicaragua and Honduras, Haiti and Dominican Republic.
- It is also found in South America, in countries such as Peru, Ecuador, Venezuela
- Also found in South and South East Asia, in countries such as Bangladesh, Nepal, Thailand, Cambodia, Philippines and Papua New Guinea.

[Any 3 regions identified, with at least 2 countries included in each region]

(ii) Using examples, explain the health and social problems faced by people living in areas where the population growth is greater than the increase in food production. [4]

- People may be **malnourished** as their body do not get the sufficient or balanced nutrients it needs to maintain healthy tissues and organ functions. There may be greater child deaths as malnutrition is the underlying cause of diarrhoea, pneumonia, malaria and measles.
- Egg of malnutrition includes **visual impairment caused by lack of Vitamin A**, osteoporosis caused by lack of calcium and Vitamin D.

- People may suffer from **starvation**, which is the state of extreme hunger from a severe lack of food. Their body becomes skeletally thin and the organs become permanently damaged and may eventually lead to death.
- When desperate to find food, people may resort to **scavenging** in landfills or garbage dumps for food. Scavenging carries health risks because scavenged food may contain high levels of bacteria or chemicals such as heavy metals of mercury and lead. Scavenging for food also place people in dangerous or illegal situations in search of food, such as trespassing private property. Scavengers are also perceived as a nuisance to the public.
- An example of scavenging in landfills is in **Smokey Mountains, Manila, the Philippines**, where people scavenge for a living

[At least 2 examples to get max of 4m, otherwise max of 3 marks. Examples could be in the form of specific sickness suffered by people.]

(b) Fig. 6 shows meat consumption of China and Europe from 1961 to 2009

Describe and account for the variation in changing consumption of meat between China and Europe from 1961 to 2009. [4]

- Europe has **higher meat consumption** than China until the late 1990s.
- China's meat consumption has been increasing from about 2 to 80 million tonnes, an **increase of about 78 million tonnes**, whereas Europe's meat consumption shows a declining trend from around 1991, when meat consumption decreases from about 61 to 50 million tonnes, a **decrease of about 9 tonnes** before increasing slightly to about 55 million tonnes in 2009.
- China's increasing meat consumption could be because of higher disposable income as a result of **rapid economic growth**. With higher income, people in China could afford to eat more meat, which is more expensive.
- Europe's declining trend of meat consumption could be due to greater awareness of **health problems** such as obesity and heart disease, which is associated with consuming red meat.

(c) Explain the social and economic factors which result in food shortage in LDCs. [5]

- In LDCs, there may be lack of transport facilities such as road and rail links to transport food to people. There may be few food outlets and people may not have easy access to food and food outlets due to lack of accessibility.
- In LDCs, there may be inadequate logistics of food distribution and storage facilities which affects food distribution. This is made worse when local production in these areas is insufficient and imports are necessary to maintain food supplies. Physical barriers such as mountains and lack of storage facilities may make it difficult for food to be distributed to some areas in LDCs, hence leading to food shortage in these areas.

- Rapid population growth in LDCs results in food supply being unable to meet the growing demand for food.
- Some LDCs such as Brazil, Russia, India and China have developing economies that grow at rates that allow them to contribute significantly to the global economy. The rise of their disposable income allows them to increase their demand for food such as meat and dairy products. This sustained growth in demand for food in these countries is believed to be depleting global food inventories, resulting in food shortages in poorer LDCs.
- The cost of fertilisers and transport has been rising, hence leading to increasing cost of producing food which results in food prices to increase too. Oil is needed to fuel farm machinery and transport farm produce and increase in oil prices will lead to increase cost of food production and hence food prices. This aggravates the problem of food shortage in LDCs as many may not afford the increase in food prices.
- Many companies and industries have converted their farmland to grow crops for biofuels, such as palm oil, as it is more profitable than growing food crops and there is a rising demand for such fuels. This leads to less farmland used to grow food crops and hence leading to lower food production and food shortages in LDCs.

(d) 'The use of biotechnology has been effective in overcoming food shortage.' How far do you agree? Give evidence to support your answer. [8]

I agree to the statement.

Biotechnology refers to the science of modifying living organisms such as plants and animals. It is generally known as genetic modification (GM) and GM food crops had their genetic make-up modified.

GM crops have a higher yield than non-GM crops. This helps farmers to earn a higher income and helps countries to be more self-sufficient in food production and therefore less dependent on food imports.

The use of biotechnology has enabled food to be produced in areas previously considered unsuitable for agriculture. It has also helped to stabilise crop yield as GM crops are more resistant to extreme weather conditions. An example of such plants is the drought-resistant corn which is tolerant of low rainfall conditions. It can be grown on the **Western Great Plains of the USA**, where the maximum rainfall received in the area is about 600 mm.

Hence, the use of biotechnology has been effective in overcoming food shortage, as food production has been increased.

However, I disagree to the statement as GM crops may be ineffective in overcoming food shortages as the use of biotechnology poses some difficulties.

GM crops are mostly grown in large-scale commercial farms in DCs due to the high capital investment involved to purchase inputs such as seeds. For many small farmers in LDCs, these GM seeds are unaffordable. Food production may remain low in these countries and food shortage still occurs.

Many consumers are wary of consuming GM food due to the potential health risks associated with them. As a result, the production of GM food is small as the demand for them is low.

Biotechnology is mainly used to increase the yield of the world's three leading cereal crops, namely corn, soya bean and canola. Its use is limited in other crops, including many that are important in Sub-Saharan Africa, such as cassava, sorghum and banana. This region faces problem of food shortage and hence biotechnology has been unable to resolve the problem of insufficient food.

Level 1 (0 – 3)

At this level answers will be generalized or with minimal support if any stand were given at all. Reasoning is rather weak and expression may be unclear. A basic answer that has little development. Answers lack examples or other evidence, or is so sketchy that it adds little support to the answer.

Level 2 (4 – 6)

Disagreement or agreement will be supported by appropriate detail. OR, both agreement and disagreement are considered, but support is patchy so that the answer is not full. Good reasoning and logic in parts of the answer with good expression in places. Some examples or other evidence will be presented to support answers in at least one place in the answer.

Level 3 (7 – 8)

At this level answers will be comprehensive and supported by sound knowledge. Both agreement and disagreement are considered and well supported. Reasoning is clear and logical with good expression of language. Examples or other evidence to support answers will be extensive.

Class:	Register No:	Name:
--------	--------------	-------



CRESCENT GIRLS' SCHOOL
SECONDARY FOUR
MID-YEAR EXAMINATION 2017

GEOGRAPHY

2236/01

Paper 1

27 April 2017

1 hour 40 minutes

Additional Materials: Answer Paper
 2 Inserts

READ THESE INSTRUCTIONS FIRST

Write your name, index number and class in the spaces provided at the top of this page and on all separate sheets of paper used.

Write in dark blue or black pen on both sides of the paper.

You may use a pencil for any diagrams or graphs.

Do not use staples, paper clips, glue or correction fluid.

Section A

Answer Question 1.

Section B

Answer **one** question.

Start each question on a fresh sheet of paper.

Candidates should support their answers with the use of relevant examples.

Sketch maps and diagrams should be drawn whenever they serve to illustrate an answer.

Insert 1 contains Fig. 3 for Question 1 and Photograph A for Question 3.

Insert 2 contains Fig. 2 for Question 1 and Fig. 6 for Question 3. Remember to hand in Insert 2 with your Answer Paper.

At the end of the examination, fasten all your work securely together.

The number of marks is given in brackets [] at the end of each question or part question.

Section A

This question is compulsory.

- 1(a) Kampong Glam, known for its eclectic blend of history, culture and picturesque streets with their beautifully restored shop houses, attracts many tourists to Singapore.

A group of students wanted to assess the environment around Kampong Glam for the impacts of tourism, specifically on the noise level, human congestion and amount of litter. They decided to do an environmental perception survey of the area (Fig. 1) and the tabulated results are provided in Table 1.

Environmental Perception Survey							
Date:				Time:			
Location:							
Impacts	Positive aspects	+ 2	+ 1	0	- 1	- 2	Negative aspects
Noise Level							
Human Congestion							
Amount of litter							

Fig. 1

Impacts	+ 2	+ 1	0	- 1	- 2
Noise Level	15	10	4	6	5
Human Congestion	0	9	3	15	13
Amount of litter	7	15	10	8	0

Table 1

- (i) Suggest what should be written for the positive and negative aspects for the environmental perception survey in Fig. 1. [3]
- (ii) Discuss the usefulness of a perception survey. [4]
- (iii) Complete Fig. 2 (Insert 2) to present the findings of the environmental perception survey. [4]

- (b) Another group of students wanted to test the hypothesis: *Tourists visited Kampong Glam mainly for cultural and religious reasons*. They conducted interviews along two streets in Kampong Glam, *Bussorah Street* and *Sultan Gate*, as shown on Fig. 3 (Insert 1), for one day during the March holidays.

Table 2 shows the responses students obtained during their fieldwork.

Reason for visiting Kampong Glam	Number of respondents	Percentage Value
Cultural and religious reasons	15	37.5%
Convenience and easy accessibility	11	27.5%
Local and international cuisines	7	17.5%
Bustling night life	4	10%
Others	3	7.5%
Total	40	100

Table 2

- (i) Describe how students might have collected the data in Table 2. [4]
- (ii) Evaluate the reliability of the data collection methods and suggest **two** ways it can be improved. [5]
- (iii) Suggest a suitable mode of presentation for the data in Table 2. Explain your answer. [3]
- (iv) What conclusion can the students make about the hypothesis? Justify your answer with evidence from Table 2. [2]

Section B

Answer one question from this section.

2(a) Study Fig. 4 which shows Havana, the capital city of Cuba.

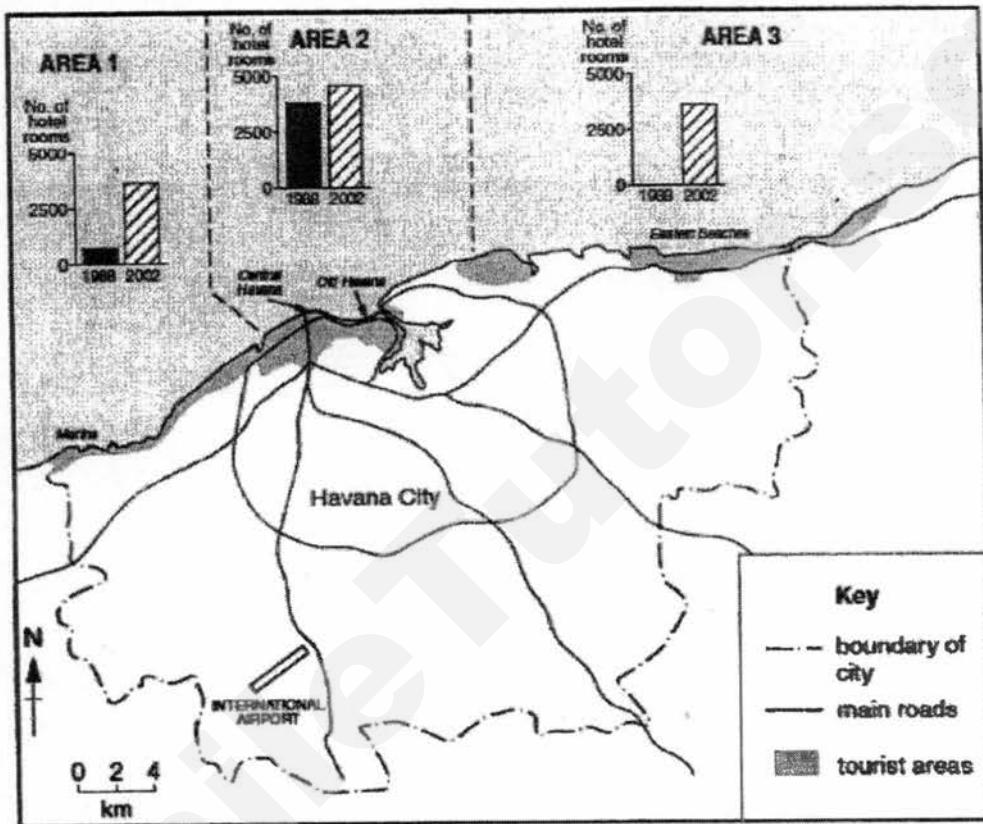

Fig. 4

With reference to Fig. 4,

(i) describe the location of the tourist areas. [3]

(ii) account for the growth of the tourist areas. [4]

(b) With reference to named example(s), suggest how LDCs can ensure sustainable tourism. [5]

(c) Study Fig. 5 which outlines the factors involved in the multiplier effect.

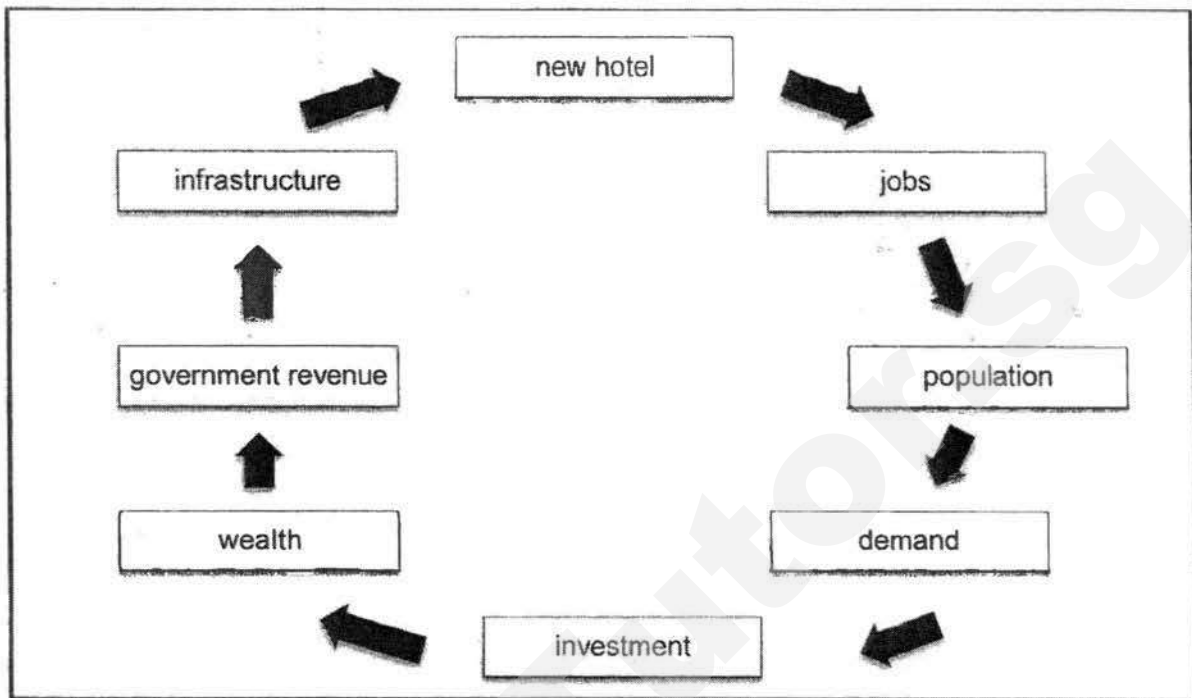

Fig. 5

With the help of Fig. 5, explain how tourism may bring about development of the area. [5]

(d) 'Tourism brings only disadvantages to the environment of countries.'

How far do you agree? Use examples to support your answer. [8]

- 3(a) Study Photograph A (Insert 1), which shows a beach and some coastal defences and Fig. 6 (Insert 2), a field sketch of the photograph.

With the aid of annotations to the sketch on Fig. 6, describe the beach and the hard engineering features used to protect the coast shown in Photograph A. [7]

- (b) Explain how an uneven coastline may be straightened over time. [5]
- (c) Study Fig. 7, which describes the medical tourism scene in Singapore.

Travellers from across Asia are making a beeline for Singapore – not to holiday here, but to seek medical treatment. Health-care providers say they are handling more patients from India, China, Cambodia and Mongolia, on top of traditional sources such as Indonesia and Malaysia.

Most sought costly treatments for ailments such as cancer and heart disease. Some foreigners choose Singapore for more personal reasons. Among them was Indian national, Timir Patel, 48. "I was having transplant surgery – which would normally scare you in India – but I felt that everything was as simple and easy as removing an appendix."

Fig. 7

Singapore is seeing an increase in the number of medical tourists. [5]

- (d) 'Planning authorities are the only ones responsible for ensuring sustainable tourism in the country.'

How far do you agree? Use examples to support your answer.

[8]

Copyright Acknowledgements:

Question 1 Fig. 3

© <https://www.google.com.sg/maps/place/Arab+St>

Question 2 Fig. 4

© Cambridge iGCSE, Specimen Paper 2016

Question 3 Photograph A

© Cambridge, GCE O Level Paper 2006

Fig. 6

© Cambridge, GCE O Level Paper 2009

Fig. 7

© The Straits Times 9 April 2012

Class:	Register No:	Name:
--------	--------------	-------



CRESCENT GIRLS' SCHOOL
SECONDARY FOUR
MID-YEAR EXAMINATION 2017

GEOGRAPHY**2236/01**

Paper 1

27 April 2017

Insert 2

1 hour 40 minutes

READ THESE INSTRUCTIONS FIRST

This Insert contains Fig. 2 for Question 1 and Fig. 6 for Question 3.

Fig. 2 for Question 1

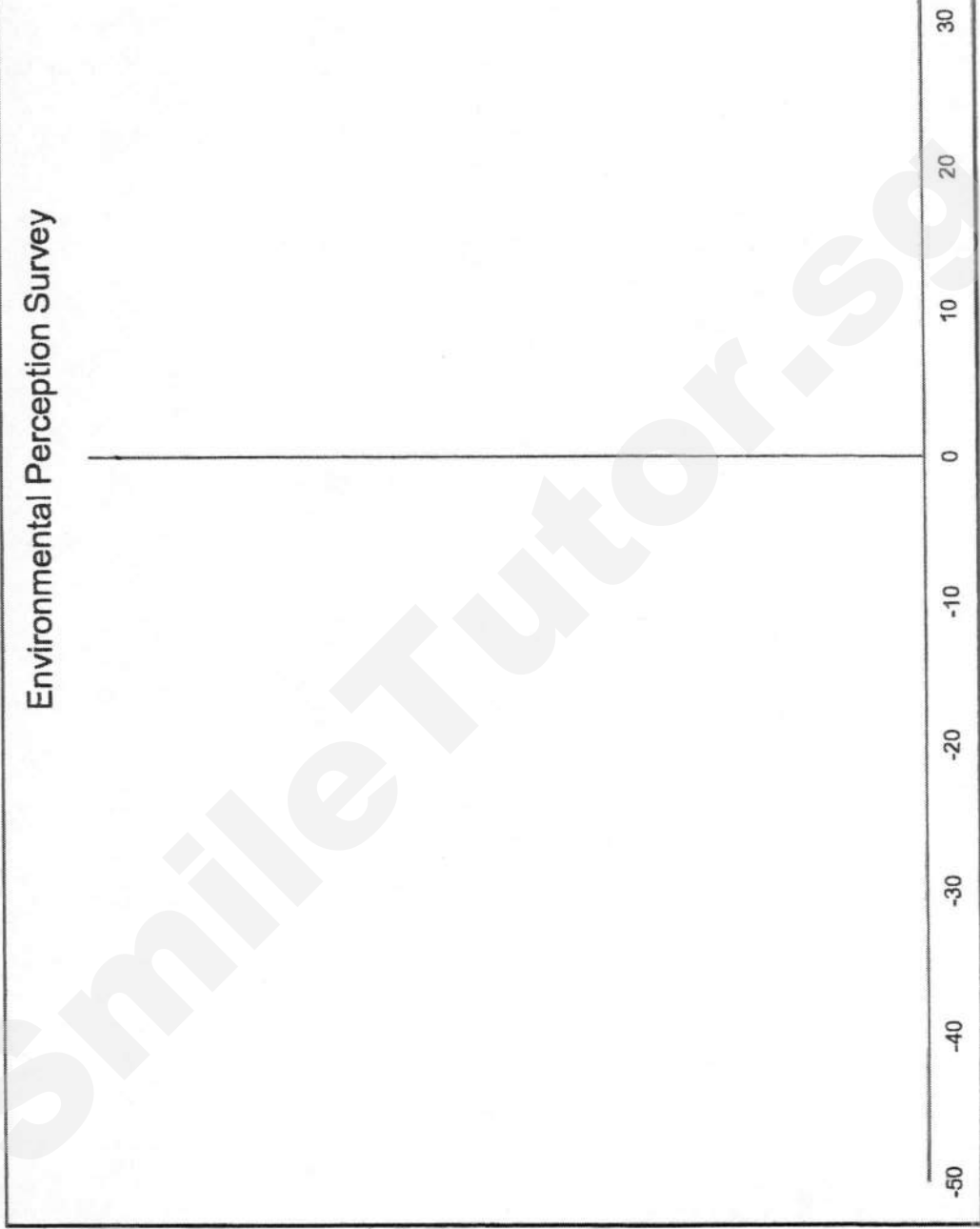

3

Fig. 6 for Question 3

A field sketch of Photograph A, showing a beach and some coastal defences

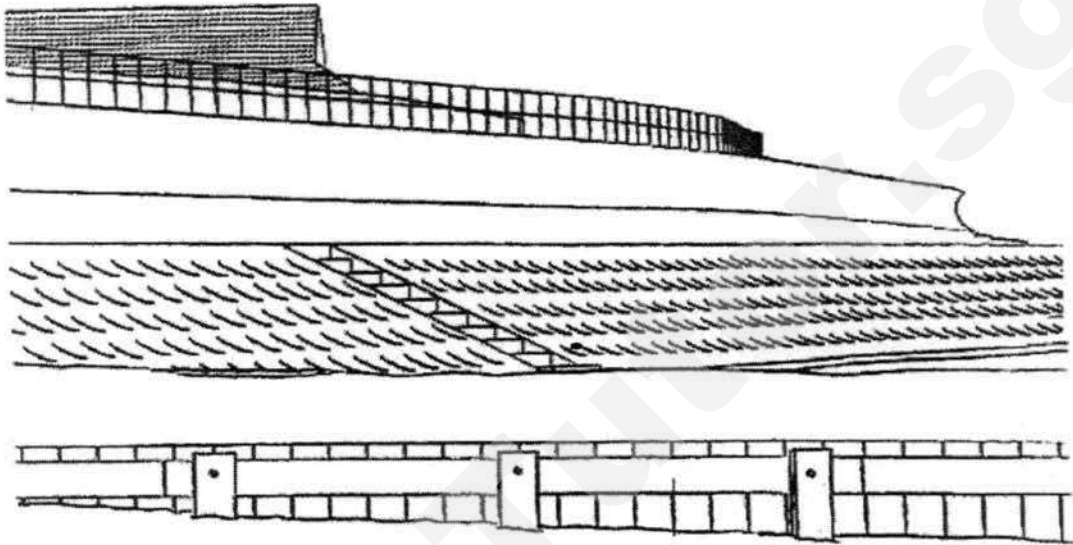

Class:	Register No:	Name:
--------	--------------	-------



CRESCENT GIRLS' SCHOOL
SECONDARY FOUR
MID-YEAR EXAMINATION 2017

GEOGRAPHY**2236/01**

Paper 1

27 April 2017

Insert 1

1 hour 40 minutes

READ THESE INSTRUCTIONS FIRST

This Insert contains Fig. 3 for Question 1 and Photograph A for Question 3.

Fig. 3 for Question 1

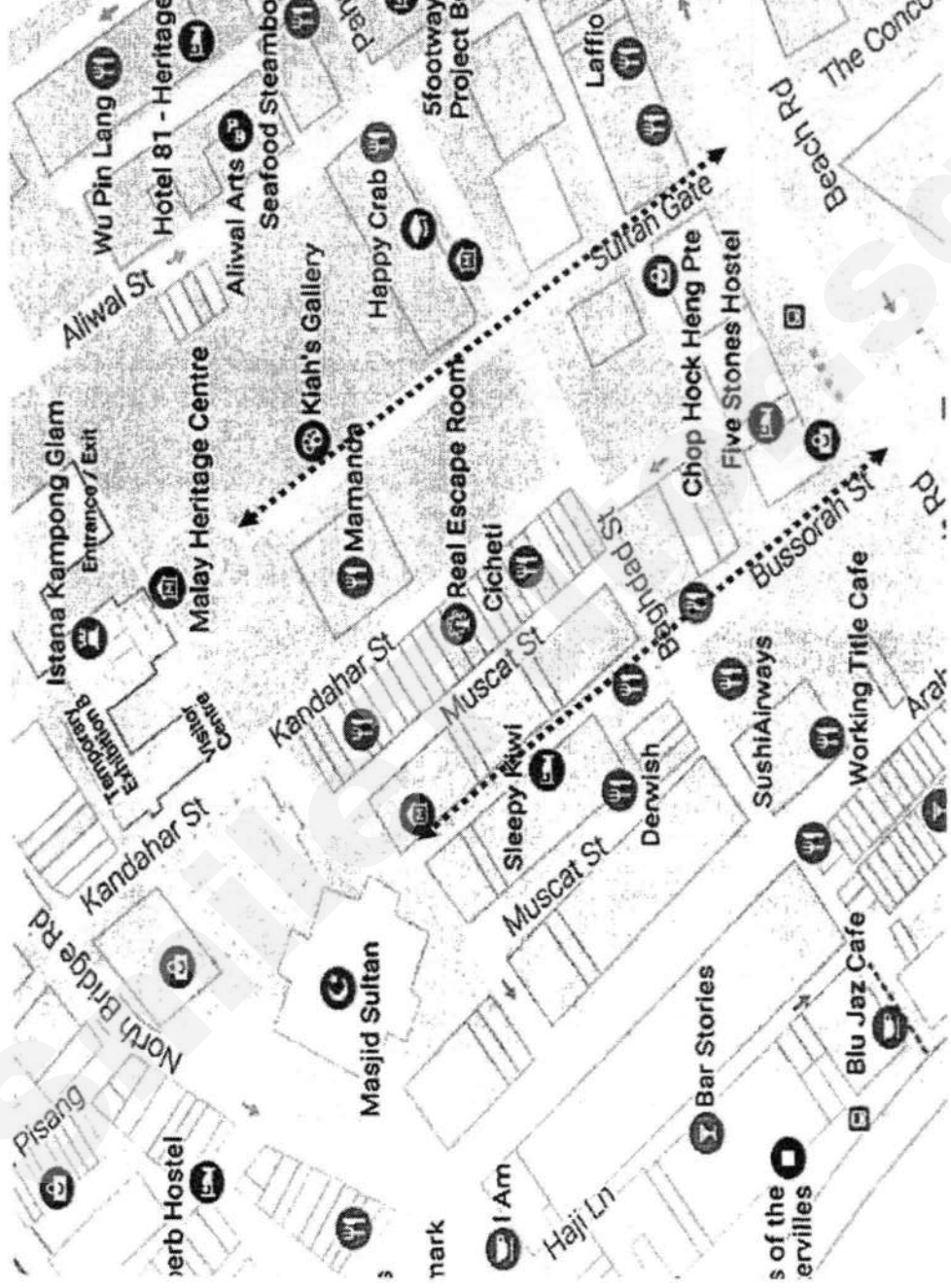

Photograph A for Question 3

A beach and some coastal defences



Copyright Acknowledgements:

Question 1 Fig. 3

Question 3 Photograph A

© <https://www.google.com.sg/maps/place/Arab+St>

© Cambridge GCE O Level Paper 2009

Need a home tutor? Visit smiletutor.sg

Class:	Register No:	Name:
--------	--------------	-------



CRESCENT GIRLS' SCHOOL
SECONDARY FOUR
MID-YEAR EXAMINATION 2017

GEOGRAPHY**2236/01**

Paper 1

27 April 2017**1 hour 40 minutes**

Additional Materials: Answer Paper
2 Inserts

Mark Scheme

Section A

This question is compulsory.

- 1(a) Kampong Glam, known for its eclectic blend of history, culture and picturesque streets with their beautifully restored shop houses, attracts many tourists to Singapore.

A group of students wanted to assess the environment around Kampong Glam for the impacts of tourism, specifically on the noise level, human congestion and amount of litter. They decided to do an environmental perception survey of the area (Fig. 1) and the tabulated results are provided in Table 1.

Environmental Perception Survey							
Date:				Time:			
Location:							
Impacts	Positive aspects	+ 2	+ 1	0	- 1	- 2	Negative aspects
Noise Level							
Human Congestion							
Amount of litter							

Fig. 1

Impacts	+ 2	+ 1	0	- 1	- 2
Noise Level	15	10	4	6	5
Human Congestion	0	9	3	15	13
Amount of litter	7	15	10	8	0

Table 1

- (i) Suggest what should be written for the positive and negative aspects for the environmental perception survey in Fig. 1. [3]

Impacts	Positive aspects	Negative aspects
Noise Level	Very quiet	Very noisy
Human Congestion	No congestion	Congested
Amount of litter	Much litter	Little litter

- (ii) Discuss the usefulness of a perception survey. [4]
Award 1 mark for each usefulness point up to a max of 2 marks and award 1 mark for each limitation point up to a max of 2 marks

Usefulness:

- Allows for the collection of quantitative data
- Useful in evaluating objectively the perception people have of the area
- Able to compare which criterion has the greatest impact
- Allows for quick and easy data collection

Limitations:

- Criteria do not have statements which makes it difficult for respondents to evaluate objectively
- Subjective opinions may not be convincing as evidence for conclusions to be drawn about hypothesis
- Criterion may contain too much jargon or geographical terminology such that respondents may not understand
- Criterion may be too broad and subjective

- (iii) Complete Fig. 2 (Insert 2) to present the findings of the environmental perception survey. [4]

Award 1 mark for accurate plotting of each category up to a max of 3 marks and award 1 mark for labels

Amt. of litter: -8, 29 (21)

Human congestion: -41, 9 (-32)

Noise level: -16, 40 (24)

- (b) Another group of students wanted to test the hypothesis: *Tourists visited Kampong Glam mainly for cultural and religious reasons*. They conducted interviews along two streets in Kampong Glam, *Bussorah Street* and *Sultan Gate*, as shown on Fig. 3 (Insert 1), for one day during the March holidays.

Table 2 shows the responses students obtained during their fieldwork.

Reason for visiting Kampong Glam	Number of respondents	Percentage Value
Cultural and religious reasons	15	37.5%
Convenience and easy accessibility	11	27.5%
Local and international cuisines	7	17.5%
Bustling night life	4	10%
Others	3	7.5%
Total	40	100

Table 2

- (i) Describe how students might have collected the data in Table 2. [4]
Award 1 mark for each point up to a max 4 marks

- Systematic sampling, of regular intervals of 10, could have been used to select the respondents
- They would interview a total of 40 tourists
- Students should station themselves along Bussorah Street and Sultan Gate in pairs/groups of 3
- They should be at each location at the same time and for the same duration

- (ii) Evaluate the reliability of the data collection methods and suggest two ways it can be improved. [5]

Award 1 mark for each reliability point up to a max of 3 marks and award mark for each suggested improvement up to a max of 3 marks

Reliability:

- Data collection was only carried out on one day
- Only 40 tourists were interviewed.
- Interviews were carried out only along two streets.

Improvements:

- Carry out the investigation over a longer period of time
- Increase the number of respondents
- Extend the interviews to include other streets in Kampong glam.

- (iii) Suggest a suitable mode of presentation for the data in Table 2. Explain your answer. *Award 1 mark for the identifying the mode of presentation and award 1 mark for each reason up to a max of 2 marks*

Mode of Presentation	Reasons
Pie chart	<ul style="list-style-type: none"> • Easy to interpret • Shows percentage total for each category
Simple bar graph	<ul style="list-style-type: none"> • Allow multiple sets of data to be compared easily • Patterns can be easily observed

(iv)

The hypothesis is valid;

Justification:

- The percentage of tourists who visited Kampong Glam for cultural and religious reasons was the highest at 37.5%.

The hypothesis is not valid;

Justification:

- Even though the percentage of tourists visiting Kampong Glam for cultural and religious reasons was the highest at 37.5% , a majority (62.5%) of them actually visited the area for other reasons.

Section B

Answer **one** question from this section.

2(a) Study Fig. 4 which shows Havana, the capital city of Cuba.

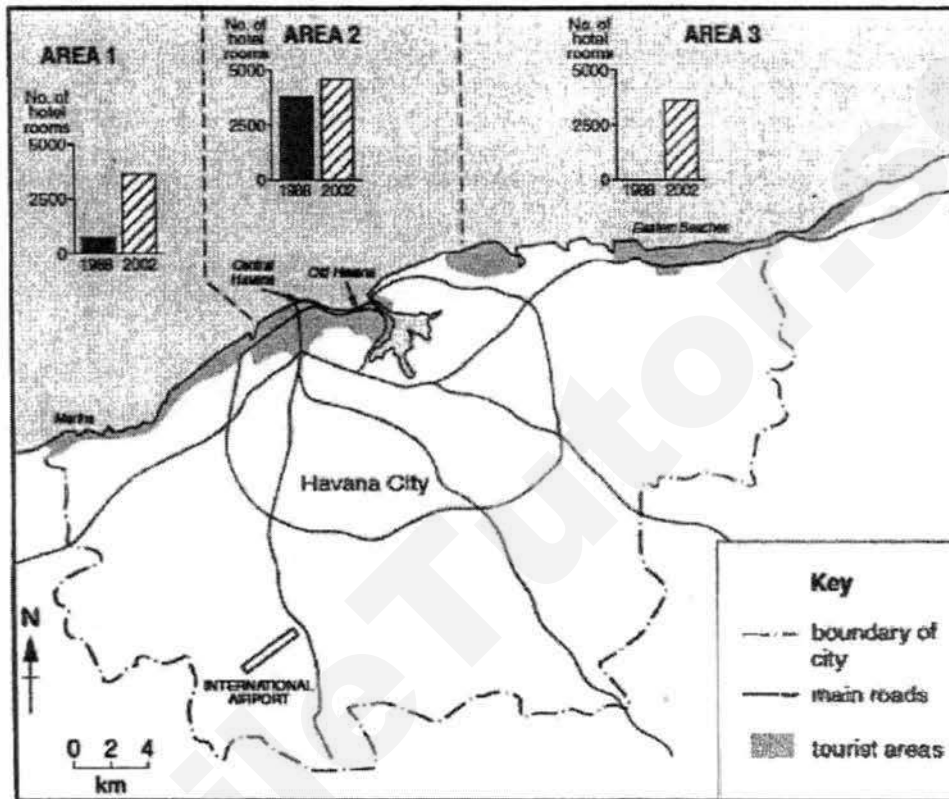

Fig. 4

With reference to Fig. 4,

(i) describe the location of the tourist areas.

Award 1 mark for each description up to a max of 3 marks

[3]

- The tourist areas are towards the north
- Located along the coast
- Mostly within the city boundary
- The Eastern Beaches extend beyond the city boundary

- (ii) account for the growth of the tourist areas. [4]
Award 1 mark for each point up to a max of 4 marks

- The city centre may have less space for new tourist accommodations, hence need to extend to other areas
- The central area has already established tourism, so the growth rate is slower than towards the east and west
- There is a main road that goes from the International Airport directly to the Central Havana
- The tourist areas are along the coasts to attract tourists who are on a beach holiday
- The Marina, located at the east, would attract cruise ships

- (b) With reference to named example(s), suggest how LDCs can ensure sustainable tourism. [5]
Award 1 mark for each suggestion up to a max of 4 marks. Award 1 mark for appropriate example(s)

- Reducing tourism leakages (e.g. Candirejo Village, Indonesia)
 - Training locals to perform skilled tourism job such as management and marketing
 - Developing homestay accommodations where visitors can pay local people directly for their accommodation
 - Promoting local food and drinks in restaurants to provide a market for local food producers and distributors
- Conservation of fragile environments
 - Careful management and use of resources so that they do not become depleted
- Limiting the number of visitors at a site to minimise congestion and degradation
- Withholding permission to proceed with tourism-related projects that could harm the environment
- Restricting tourists from some areas where only locals can enter

(c) Study Fig. 5 which outlines the factors involved in the multiplier effect.

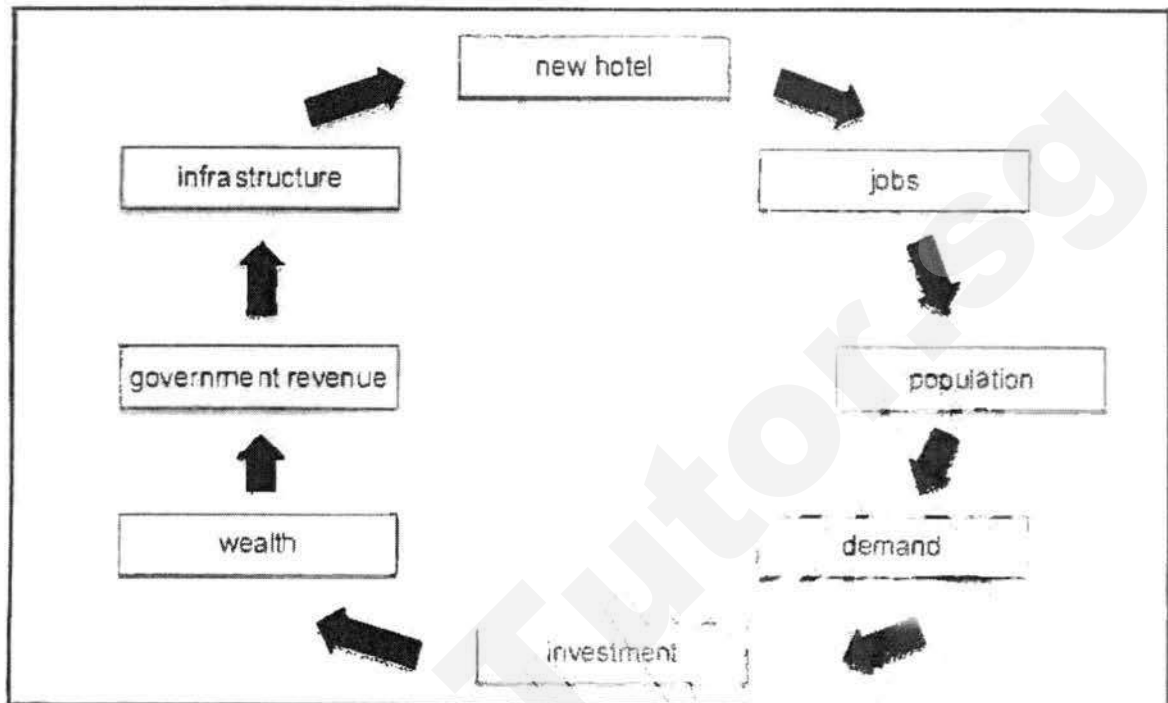

Fig. 5

With the help of Fig. 5, explain how tourism may bring about development of the area. [5]

Award 1 mark for each point up to a max of 5 marks

- The development of a new hotel will result in the creation of jobs, either direct or indirect employment
- When there are jobs available, people would be attracted to the area to live which results in an increase in population in the area
- This increase in population would in turn cause an increase in the demand for goods and services, which would attract business to invest in the area
- With more businesses and more people being employed, there would be an increase in government revenue through taxes
- The government would be able to improve the infrastructure of the area using the revenue generated, leading to the development of the area

(d) 'Tourism brings only disadvantages to the environment of countries.'

How far do you agree? Use examples to support your answer.

[8]

	Benefits	Problems
Social-cultural	<ul style="list-style-type: none"> • preservation of culture and local customs 	<ul style="list-style-type: none"> • dilution of culture and local customs • increased crime
Economic	<ul style="list-style-type: none"> • employment opportunities • growth in income • increase in foreign exchange • infrastructure development 	<ul style="list-style-type: none"> • seasonal unemployment • underuse of facilities • shortage of services
Environment	<ul style="list-style-type: none"> • conservation of natural environments 	<ul style="list-style-type: none"> • increased congestion • vandalism • pollution and littering • destruction of habitats • increased carbon footprint

A full answer does not need to include all the above points
Candidates at each level will show the following characteristics.

Level 1 (0-3 marks)

- At the level, answers will lack detail
- A basic answer that has little development
- There may be little or no attempt at assessment of factors
- An example may or may not be given

Level 2 (4-6 marks)

- At least two factors are considered, but support is patchy so that the answer is not full
- Assessment may be given but this usually amounts to simple declarations which are general in nature
- An example will be presented to support answers in at least one place in the answer

Level 3 (7-8 marks)

- Answers will be comprehensive and supported by sound knowledge
- There will be assessment of the extent of benefits/problems brought about by tourism
- Examples to support answers can be found in most places in the answer

- 3(a) Study Photograph A (insert 1), which shows a beach and some coastal defences and Fig. 6 (insert 2), a field sketch of the photograph.

With the aid of annotations to the sketch on Fig. 6, describe the beach and the hard engineering features used to protect the coast shown on Photograph A. [7]

Award 1 mark for each annotation up to a max of 7 marks

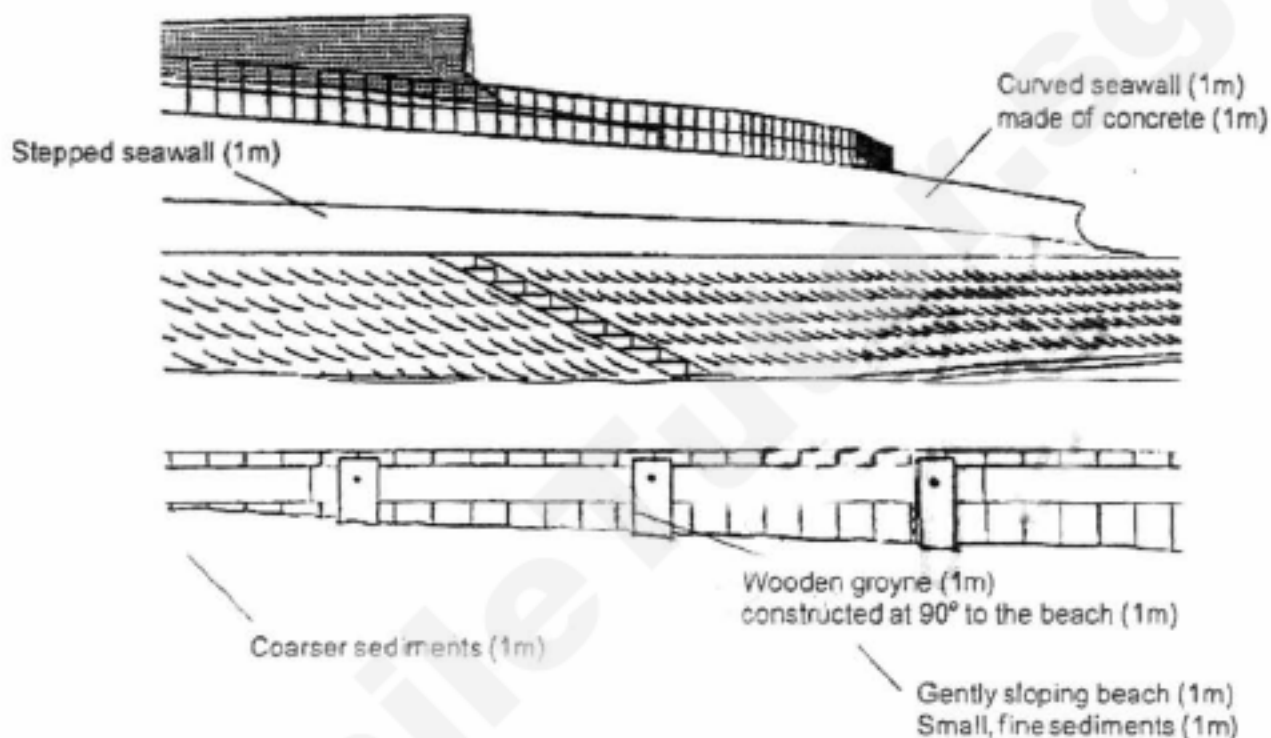

- (b) Explain how an uneven coastline may be straightened over time. [5]
Award 1 mark for each point up to a max of 5 marks

- When waves approach the indented coast with headlands and bays in a parallel manner, wave refraction occurs.
- Waves reach the water off the headlands first and slow down.
- At the headland, the waves converge or curve in. This is due to the shallower waters there, causing waves to break. Energy is concentrated and the headland undergoes more erosion.
- Conversely, the waves diverge or curve out in the bay. The deeper waters allows the wave to break very near the coast. Energy is thus diffused, deposition at the bay area occurs.
- Eventually, the coastline becomes straightened.

(c) Study Fig. 7, which describes the medical tourism scene in Singapore.

S

Travellers from across Asia are making a beeline for Singapore – not to holiday here, but to seek medical treatment. Health-care providers say they are handling more patients from India, China, Cambodia and Mongolia, on top of traditional sources such as Indonesia and Malaysia.

S

Most sought costly treatments for ailments such as cancer and heart disease. Some foreigners choose Singapore for more personal reasons. Among them was Indian national, Timir Patel, 48. "I was having transplant surgery – which would normally scare you in India – but I felt that everything was as simple and easy as removing an appendix."

S

Fig. 7

Singapore is seeing an increase in the number of medical tourists.

[5]

Award 1 mark for each point up to a max of 5 marks

- Good reputation
- The required treatment may not be available in their home country, which are mainly LDCs
- Close proximity to their home country
- Availability of skilled medical personnel
- Wide variety of cuisine available
- English is commonly spoken in Singapore
- Accessibility of Singapore

- (d) 'Planning authorities are the only ones responsible for ensuring sustainable tourism in the country.'

How far do you agree? Use examples to support your answer. [8]

	Strengths	Limitations
Planning authorities (STB, Singapore)	<ul style="list-style-type: none"> • Develops and maintain infrastructure and attractions • Draft laws and policies • Work with other government agencies 	<ul style="list-style-type: none"> • Difficult to plan for unforeseen factors • Opposing stakeholders
Local Communities (Candirejo Village, Indonesia)	<ul style="list-style-type: none"> • Locals are involved in decision making • Increase in tourism-related employment and businesses for locals 	<ul style="list-style-type: none"> • Difficulty in obtaining external funding • Shortage of skilling labour
Visitors	<ul style="list-style-type: none"> • Fund conservation and preservation • Provide income for locals • Raise awareness to conserve and preserve attractions 	<ul style="list-style-type: none"> • Damage tourist attractions • Dilute local culture and Customs
NGOs (TIES)	<ul style="list-style-type: none"> • Facilitate communication between various stakeholders • Support various stakeholders in managing the impact of tourism 	<ul style="list-style-type: none"> • Difficulty in obtaining external funding
Tour operators (PAT)	<ul style="list-style-type: none"> • Provide feedback on tourist attractions • Regulate tourist behaviour 	<ul style="list-style-type: none"> • Need to generate profits

A full answer does not need to include all the above points
Candidates at each level will show the following characteristics:

Level 1 (0-3 marks)

- At the level, answers will lack detail
- A basic answer that has little development
- There may be little or no attempt at assessment of stakeholders
- An example may or may not be given

Level 2 (4-6 marks)

- At least two stakeholders are considered, but support is patchy so that the answer is not full
- Assessment may be given but this usually amounts to simple declarations which are general in nature
- An example will be presented to support answers in at least one place in the answer

Level 3 (7-8 marks)

- Answers will be comprehensive and supported by sound knowledge.
- There will be assessment can be extend of responsibility of the various stakeholders
- Examples to support answers can be found in most places in the answer.

Class:	Candidate Name:	Candidate Index Number:
--------	-----------------	-------------------------



**EDGEFIELD SECONDARY SCHOOL
2017 MID YEAR EXAMINATION
Secondary 4 Express**

GEOGRAPHY

2236/02

Paper 2

May 2017

Additional Materials: Writing Paper

1 hour 30 minutes

READ THESE INSTRUCTIONS FIRST

Write your name, index number and class on all the work you hand in.
Write in dark blue or black pen.
You may use a soft pencil for any diagrams, graphs or rough working.
Do not use staples, paper clips, highlighters, glue or correction fluid.

Section A

Answer **one** question.

Section B

Answer **one** question.

At the end of the examination, fasten all your work securely together.
The number of marks is given in brackets [] at the end of each question or part question.

FOR EXAMINER'S USE	
SECTION A	/ 25
SECTION B	/ 25
TOTAL	/ 50

My target grade/mark: _____

Parent's signature

Section A

Answer one question from Section A

1.

Table 1 shows some earthquake occurrences with at least 7.0 magnitude in the year 2016.

Magnitude	Death toll	Location	Focus Depth (km)	Date
7.8	0	Indonesia	24.0	March 2
7.8	661	Ecuador	21.0	April 16
7.2	0	Russia	163.2	January 30
7.2	0	South Georgia and the South Sandwich Islands	72.7	May 28
7.0	40	Japan	10.0	April 11
7.0	0	Vanuatu	27.2	April 28

Table 1

- (a) Using information from Table 1, describe and account for the difference in death tolls between **Japan** and **Russia** in 2016. [3]
- (b) Study Fig. 1, which shows the impact of earthquake in Japan, 2011.



Fig. 1

<http://www.sify.com/news/factbox-economists-estimate-of-japan-earthquake-impact-news-environment-and-nature-ldpo4jdigibsi.html>

Using information from Fig. 1, describe and explain the social and economic impact of earthquake in Japan. [4]

- (c) Study Fig. 2, which shows the world's tectonic plates and their movements.

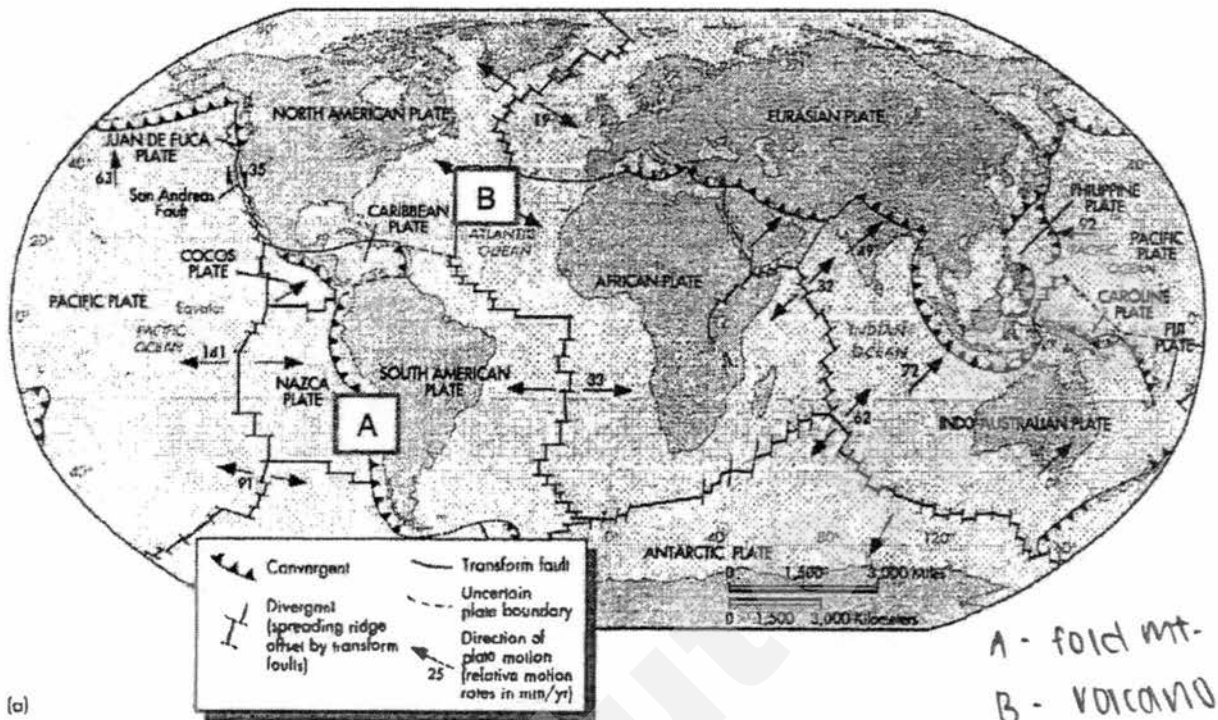

Fig. 2

Using information from Fig. 2, differentiate the processes leading to the formation of landforms found in locations A and B. [6]

- (d) 'Living near volcanoes has many benefits.' Justify this statement with relevant examples. [4]
- (e) Assess the effectiveness of short term and long term responses to earthquakes. Support with relevant examples. [8]

2(a) Study Fig. 3, which shows the climograph of a country.

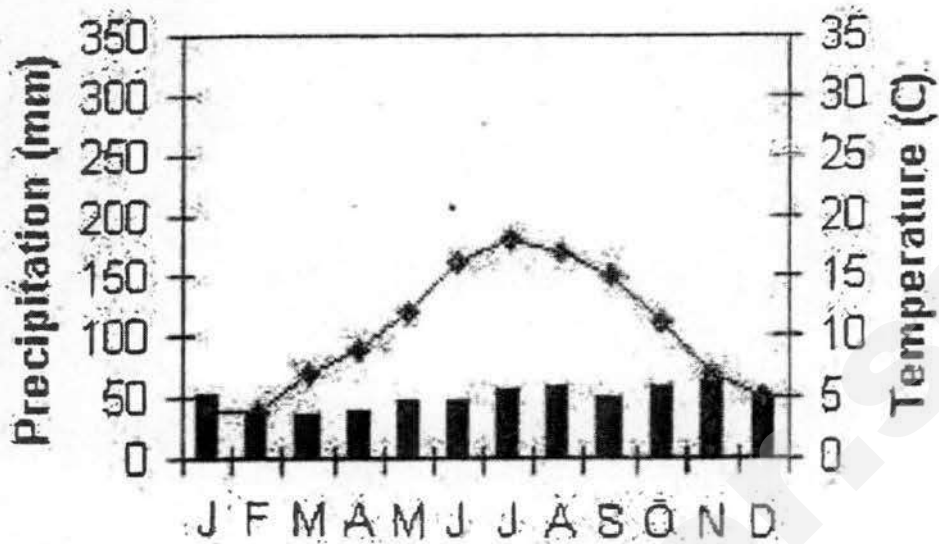

Fig. 3

http://www.earthonlinemedia.com/ebooks/tpe_3e/climate_systems/marine_west_coast.html

Identify and describe the climate shown in Fig. 3.

[3]

(b) 'Global warming has brought about only negative effects'. Justify this statement with relevant examples.

[4]

(c) Study Fig. 4a and 4b, which show the two types of monsoon.

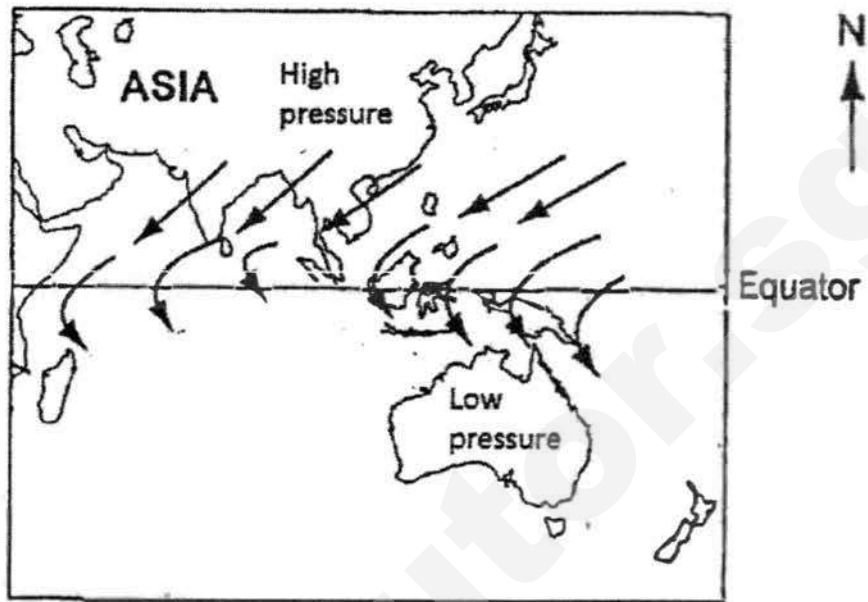

Fig. 4a

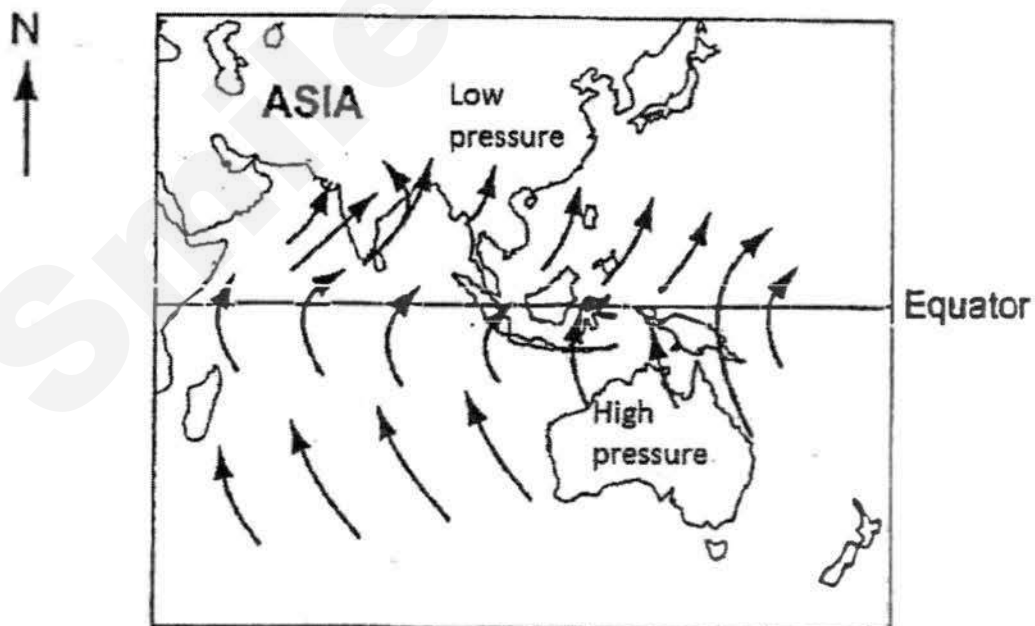

Fig. 4b

Source: Adapted from GCE O Level 2234/01 Oct/Nov 2005 Q16

Using information from Fig. 4a and 4b, differentiate the air pressure and movement of winds between the two seasons. [6]

- (d) Study Fig. 5, which shows a newspaper article on the effects of tropical cyclone, Typhoon Haiyan in 2013.

Typhoon Haiyan makes landfall in Philippines

As Typhoon Haiyan tore across the eastern Philippines, family coconut plantations were smashed like matchsticks and call centres that serve the world fell silent. The storm that killed thousands also wrecked livelihoods in the worst-hit region, a blow that will be felt long after the disaster fades from attention.

At a call and data centre in Palo, 9 kilometres from Tacloban, chairs, desks and computers are soaked in water and caked with dirt. The building was not hit by Haiyan's storm surge but high winds peeled off iron sheet roofing as more than 500 people huddled inside, leaving only the steel frame skeleton and soaking everything below. No one died there but some employees lost family elsewhere.

Fig. 5

Using information from Fig. 5, describe and explain the impact of Typhoon Haiyan.

[4]

- (e) With reference to examples, assess the effectiveness of mitigation measures used to reduce the impact of tropical cyclones.

[8]

Section B

Answer one question from Section B

- 3.(a) Study Fig. 6, which shows malaria death by country in Africa per 1000 population in 2010.

Cumulative probability of malaria death, % and per 1,000 population, 2010

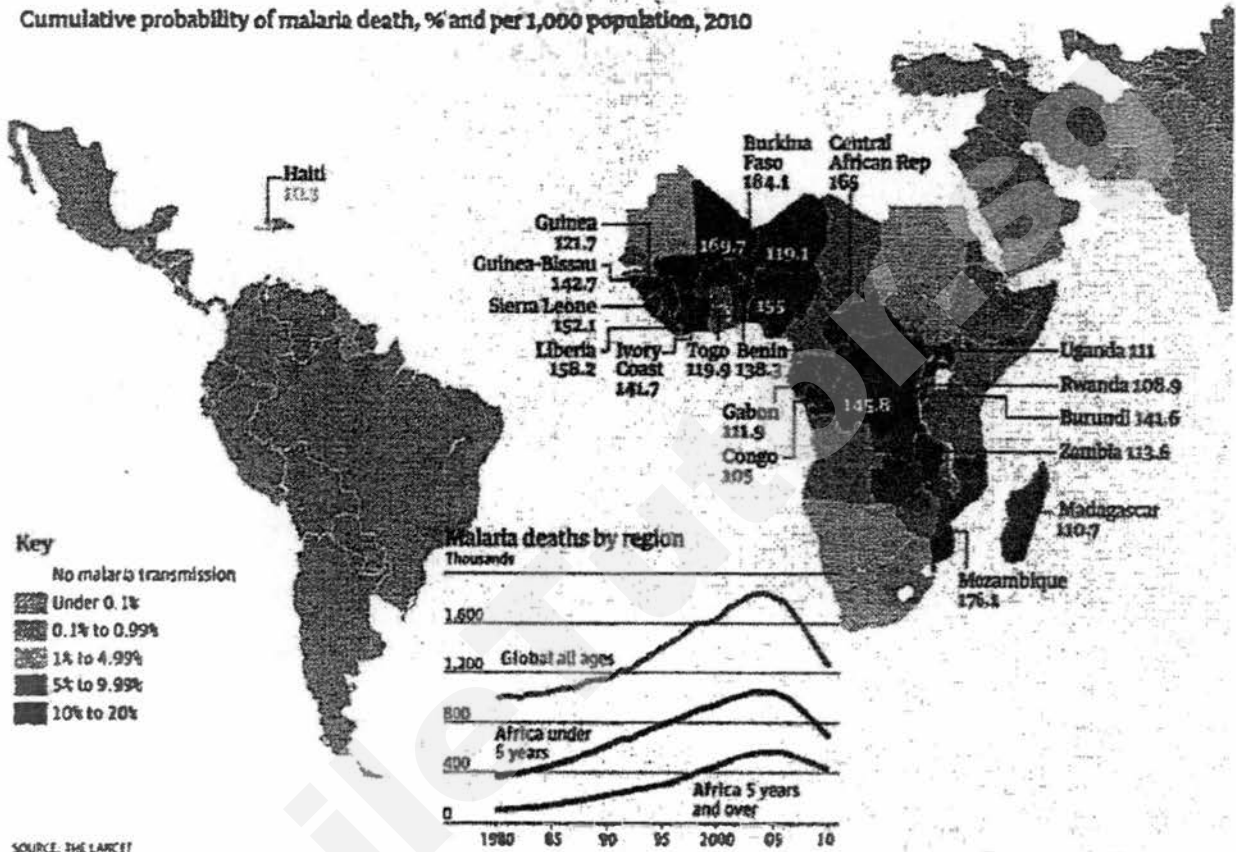

Fig. 6

Using information from Fig. 6, describe the distribution of malaria death in Africa per 1000 population in 2010. [3]

- (b) Explain the challenges in containing the spread of malaria. [4]

- (c) Study Fig. 7, which shows the average food consumption over the years from 1965 to 2025.

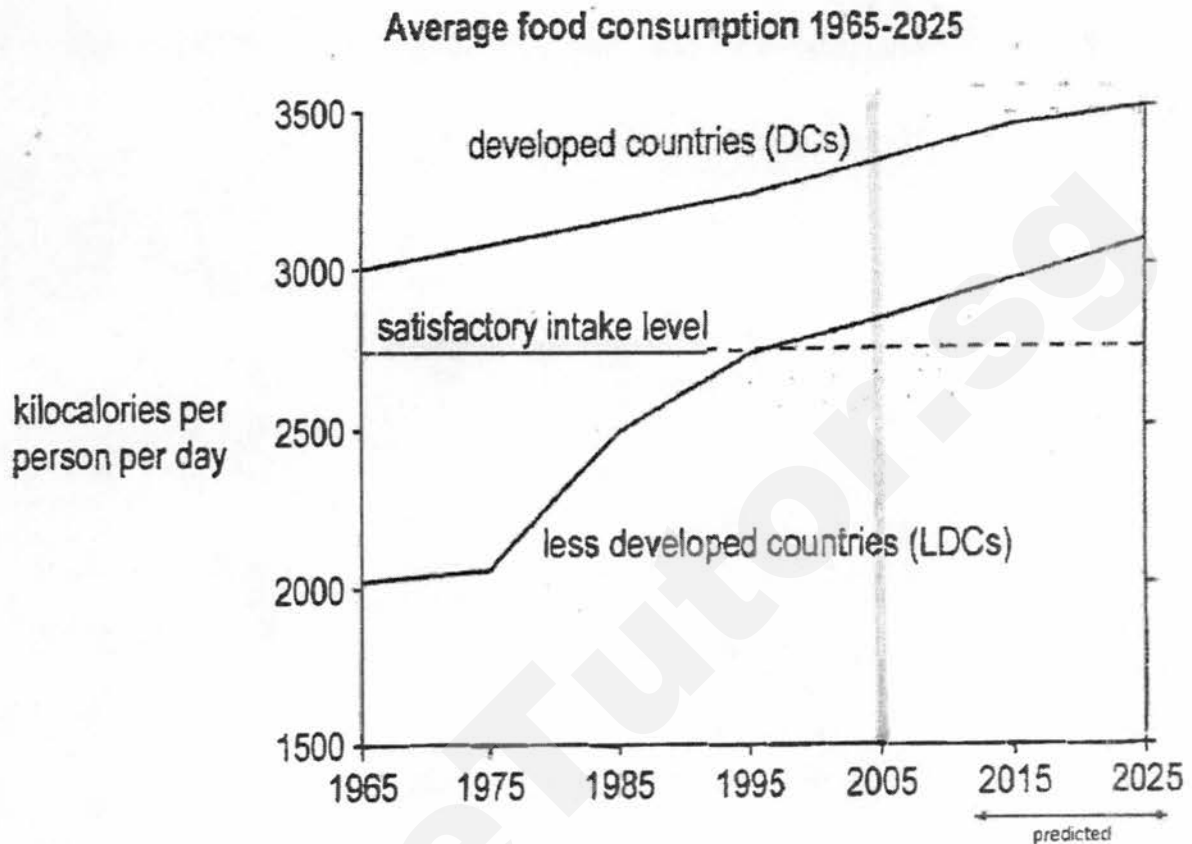

Fig. 7

Using information from Fig. 7, describe and explain the average food consumption trend between developed countries (DCs) and less developed countries (LDCs) from 1965 to 2005. [6]

- (d) Explain the impact of food consumption on the people and the economy for DCs if the trend continues as shown in Fig. 7. [4]
- (e) With reference to example, assess the effectiveness of using technology to increase food production. Support your answer using evidence. [8]

4(a) Study Fig. 8, which shows how malaria is being transmitted.

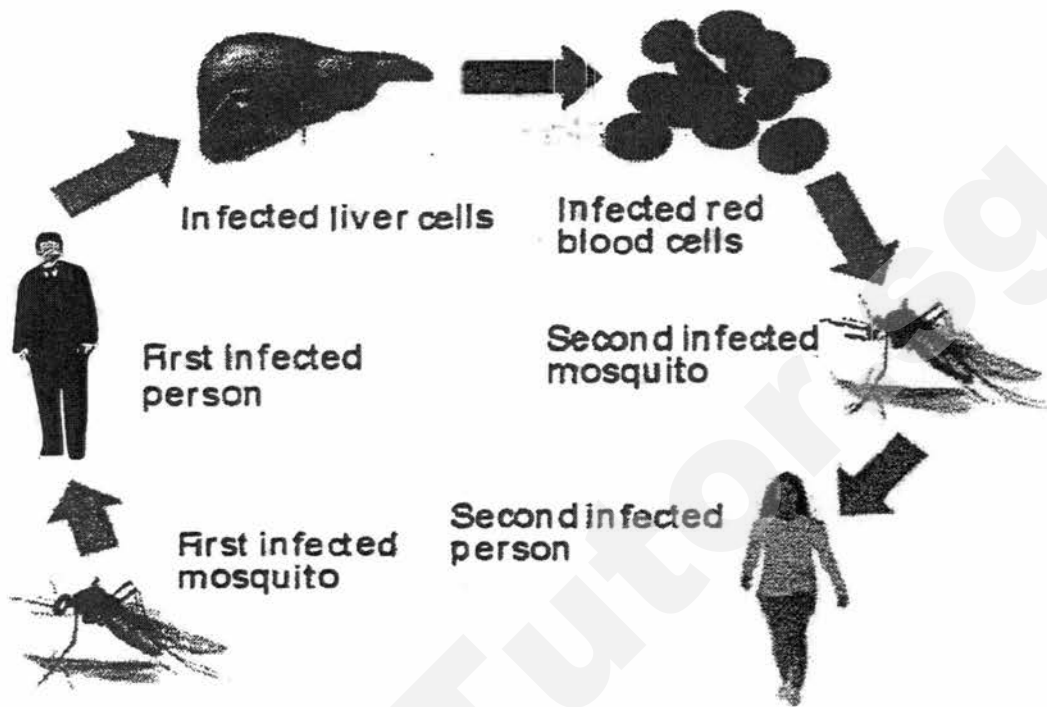

Fig. 8

<http://www.malaria-globalinitiative.com/malaria.php>

Using information from Fig. 8, describe how malaria is being transmitted. [3]

(b) Study Fig 9, which shows factors that contributed to the spread of malaria.



Fig. 9

<http://naniwillie.blogspot.sg/>

Explain how the environmental factors shown in Fig 9 have contributed to the spread of malaria. [4]

Need a home tutor? Visit smiletutor.sg

- (c) Study Fig. 10, which shows the impacts of HIV/AIDS.

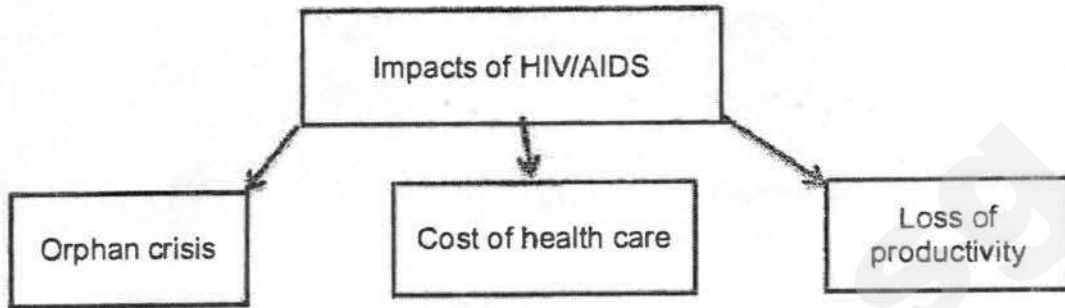

Fig. 10

- Explain the impacts of HIV/AIDS. Support with relevant examples. [6]
- (d) Explain the challenges in containing the spread of HIV/AIDS. [4]
- (e) Assess the effectiveness of implementing precautionary and mitigation measures to reduce the impact of a disease or health problem in Singapore. [8]

End of paper

Edgefield Secondary School

Answer Scheme for Sec 4 Express Pure Geography Paper 2 Mid-Year Examination 2017 + TOS

Question	Answers	AO 1+2	AO 1+3
1a.	<p>Japan has a higher death toll than in Vanuatu at 40 deaths compared to 0.</p> <p>Depth of focus is different. Japan depth of focus is 10 km while the depth of focus of Vanuata is at 27.2km.</p> <p>The deeper the depth of focus of the earthquake, the more distance from the surface of the earth and hence, the impact of the earthquake is less felt as the energy would have dissipated more, if it started from a deeper depth.</p>	<p>1</p> <p>1</p>	1
1b.	<p>Social impact</p> <ul style="list-style-type: none"> • Destruction of homes – homeless • Destruction of infrastructures – interruption to traffic thus lack of accessibility <p>Economic impact</p> <ul style="list-style-type: none"> • Need to channel funds for repair and rebuild, thus slows down for development. • Decrease in tourist arrivals due to government travel advisory, thus less revenue earn and slows down economic development 	1	
1c.	<p>Location A: Process: Divergent plates movement 2 oceanic plates move away from one another Oceanic plates diverge and results in sea floor spreading</p> <p>Landform: Ridge (Mid-Atlantic) Volcanic islands</p> <p>Location B: Process: Convergent plates movement 1 oceanic and 1 continental plates move towards one another Oceanic plate subduct under the continental plate</p> <p>Landform: Trench Volcanoes</p>	<p>1</p> <p>1</p> <p>1</p> <p>1</p> <p>1</p> <p>1</p> <p>1</p> <p>1</p> <p>1</p>	

1d.	<p>Agree</p> <p><u>Fertile volcanic soil</u></p> <ul style="list-style-type: none"> • Lava and ash from the volcanic eruptions break down to form fertile volcanic soils, favourable for agriculture • For example, the volcanic soils of Java and Bali in Indonesia support the cultivation of crops such as tea, coffee and rice, which is important for food consumption and earning revenue <p><u>Precious stones and minerals, building materials,</u></p> <ul style="list-style-type: none"> • Volcanic rocks can be rich in precious stones and minerals • For example diamond, which is used as industrial tools and in scientific research as well as a form of income for the locals <p><u>Tourism</u></p> <ul style="list-style-type: none"> • Many people/ tourists visit volcanoes to hike and camp in the area or simply to enjoy the scenery • Volcanic areas are rich in history and people can visit these areas to learn more about them as well as providing a source of income for the locals when they work as guides <p>Geothermal energy</p> <ul style="list-style-type: none"> • The hot water or stream can be harnessed to produce electricity for the homes • For example, electricity or over 70% of homes in Iceland is generated from geothermal power because of the large number of volcanoes in the country 	1 1 1 1 1	
1e.	<p>Short-term responses are those that occur immediately and last for weeks after the occurrence of an earthquake. Short-term include providing survivors with the basic necessities of food, water and shelter</p> <p>A) Search and rescue People trapped under collapsed buildings are quickly located and freed</p> <p>Success Some survivors who are found after being trapped in the buildings without food</p>		

For example after the earthquake in Tohoku, Japan in 2011, sniffer dogs and heat sensors were deployed and successfully rescued many who were trapped

Limitation

Rescue workers only have a limited time of 72 hours, or 3 days, to find trapped survivors
Without food and water, people who are trapped are unlikely to survive after 3 days

For example, rescue workers had a limited time of 3 days to rapidly search through 2 towns after the earthquake in Tohoku in 2011

B) Emergency, food and medical supplies

The injured are being treated and clean drinking water provided for survivors to prevent dehydration and the spread of diseases

Success

The provision of immediate aid helps survivors continue with their lives

For example, after the earthquake in Afyon in 2002, the Turkish Red Crescent Society immediately responded by delivering 20 000 tents, 50 000 blankets and 3000 heaters to the region.

Limitation

Medical supplies, food and water may not be sufficient and this may cause social unrest

For example, after the earthquake in Haiti in 2010, looting and fighting broke out as people fought for food and medical supplies.

Long-term responses are those that can stretch over months and years and involve rebuilding an affected region. However, carrying out such measures and responses can be costly.

C) Rebuilding of infrastructure

Infrastructure and amenities are rebuilt and improved upon after a disaster

Success

Authorities develop stricter building codes to ensure that infrastructure is restored at a higher safety level than before

	<p>For example, after the earthquake in Kobe, Japan in 1995, Japan government spent billions of dollars developing technology to build more earthquake-resistant buildings</p> <p>Limitation Reinforced buildings, which are built to protect against earthquakes, are not necessarily protected against tsunamis. Additional protection could be in the form of coastal protection structures such as breakwaters.</p> <p>For example, although many of Chile's buildings are earthquake-resistant, the coastal areas suffered massive damage from tsunami when the earthquake struck in 2010</p> <p>D) Provision of health care Health options such as long-term counseling are provided. The loss of loved ones, homes or jobs after earthquakes cause long-lasting trauma</p> <p>Success Problems can be identified and addressed early.</p> <p>For example, a year after the earthquake in Christchurch, New Zealand in 2011, significant Problems of anxiety and depression were identified amongst all age groups of the affected population. This resulted in a greater number of health workers Being deployed in the area</p> <p>Limitation Improving health options, such as restoring the resilience of people after an earthquake, can be very challenging. For example, many survivors, such as those in Haiti after the earthquake in 2010, continue to lack access to basic necessities</p>		8
2a.	<p>Cool temperate</p> <p>Temperature: Large temperature range of about (13°C)</p> <p>Rainfall: Evenly distributed throughout the year Moderate rainfall of about 600mm per year</p>	<p>1</p> <p>1</p> <p>1</p>	1

2b.	<p>Agree</p> <p><u>Sea level rise</u> Higher temperatures cause seas and oceans to expand and glaciers in Greenland and Antarctica to melt, adding meltwater to the sea, thus causing a rise in sea level.</p> <p>Rising sea levels threaten low-lying areas and islands. The lives and property of people living near these areas are threatened by the possibility of flooding.</p> <p><u>Extreme weather conditions</u> Increase in temperature has caused an increase in the evaporation rates, thus countries with wetter climates like China and South East Asia are more prone to flooding, destroying homes, industries and infrastructures.</p> <p>Strong winds from tropical storms have also disrupted economic activities like tourism and caused heavy economic losses as property crops and businesses were destroyed. For example, the Hurricane Wilma (2005) has devastating effects on the southeastern region of USA, Mexico.</p> <p>Places in the drier region like Sahel, experience droughts when temperature increases. High temperatures increase evaporation rates, causing lakes and rivers to dry up. The increase in temperatures has also led to heat waves in Milan, Italy, causing many deaths</p> <p><u>Spread of infectious insect-borne diseases</u> Increased rainfall and temperatures is favourable for mosquitoes to breed and this allows spread of insect-borne diseases like malaria and dengue fever</p> <p>As temperate countries like Europe and North America get warmer, mosquitoes are able to breed further. For example, dengue fever was reported in the cool climate areas of Nepal and Bhutan for the first time in 2004.</p>	<p>1</p> <p>1</p> <p>1</p> <p>1</p> <p>1</p> <p>1</p> <p>1</p>	
2c.	<p>Fig A shows high pressure in Central Asia and low pressure in Australia while</p> <p>Fig B shows low pressure in Central Asia and high pressure in Australia</p>	<p>1</p> <p>1</p>	

	<p>Wind blows from high pressure to low pressure</p> <p>Fig A: Monsoon wind blows from Northeast from Central Asia to Australia Coriolis effect deflects the wind to the left and becomes northwest wind which picks up moisture from Indian Ocean and pours in Australia</p> <p>Fig B: Monsoon wind blows from Southeast from Australia to Central Asia Coriolis effect deflects the wind to the right and becomes southwest wind which picks up moisture from Indian Ocean and pours in Central Asia</p>	<p>1</p> <p>1</p> <p>1</p>	
2d.	<p>Coconut plantations were smashed like matchsticks causing farmers to suffer a loss.</p> <p>Storm killed thousands also wrecked livelihoods causing people to die and homeless.</p> <p>High winds peeled off iron sheet roofing as more than 500 people huddled inside, leaving only the steel frame skeleton and soaking everything below causing government to spend money on repairs</p>	<p>1</p> <p>1</p> <p>1</p> <p>1</p> <p>1</p>	
2e.	<p><u>Mitigation measure: Prediction and warning</u> Predicting cyclones is by analysing long-term climate records This method is effective because by analyzing the pattern of occurrences, it helps to establish the pattern of occurrences and the severity of past cyclones to predict future cyclones</p> <p>However, this method has limitations because these records of past events only indicate the frequency of tropical cyclones and does not give accurate details about when future tropical cyclones will occur</p> <p><u>Computer modelling</u> This method is effective because it allows predictions to be made about the cyclones's path, as well as the likely areas which may be affected and the degree of damage</p> <p>However, this method has limitations because the predicted paths of tropical cyclones may not be completely accurate as predictions are based on weather information available at the particular point in time and weather conditions may change quickly</p>		

Mitigation measure: Land use control**Coastal plain management**

This method may be effective as restrictions are placed on areas along the coasts that are vulnerable to storm surges and flooding and to discourage development in these vulnerable areas, and thus reducing the number of casualties likely to be hit by these hazards

Developers are also required to pay higher taxes for use of land along the coast, and this is to discourage developments in these areas

Protected zones can be allocated and these areas are not allowed to have any development, in addition these protected zones serve as a barrier against storm surges and flooding

However, this method has limitations because effective implementation of such enforcement needs time and manpower

Moreover, many developments found along these coastal areas may be around for a long time and many residents who live along these coastlines are often reluctant to move out

Government needs to buy back the land to convert the land into recreational areas and it may be very costly to do so

Mitigation measure: Floodplain management

Floodplain management: Master plan to reduce the flood damage potential

Mapping the land use of an area and implementing measures to prevent floods

This method may be effective and can be achieved by ensuring new developments on floodplains are not prone to flooding and reducing flood damage potential in already developed floodplains

The master plan also draws up evacuation plans ensuring people are able to leave a flooded area as quickly as possible

However, this method has limitations because the measures implemented might not be able to cope with the large amount of rainfall and storm surge thus areas still get flooded

Mitigation measure: Reducing vulnerability of infrastructure

Infrastructure needs to be able to withstand the

	<p>impacts of tropical cyclones</p> <p>Reducing the vulnerability of infrastructure includes designing buildings that are resistant to wind and water damage, regular inspection of river embankment and coastal dikes for breaches due to erosion, and locating utility lines underground</p> <p>Wind and water resistant buildings by introducing galvanized steel hurricane ties that are nailed to the roof to prevent it from being blown off by the strong winds of tropical cyclones</p> <p>A layer of secondary water resistance is added to the roofs of houses to prevent leaking if the roof is blown off during the tropical cyclone</p> <p>For example, in Florida, USA, the state government aids homeowners by employing specialized companies to improve the design of the roof and the openings of houses</p> <p>This measure is effective because the houses of most citizens living on Jensen Beach in Florida suffered only minor roof damage when hurricane Wilma struck in 2005.</p>			8
3a.	<p>Highest at Northwest part of Africa; Burkina Faso (184.1 per 1000 population)</p> <p>And Southeast part of Africa: Mozambique (176.1 per 1000 population)</p> <p>Lowest at Central part of Africa: Congo (105 per 1000 population) Rwanda (108.9 per 1000 population)</p>			1 1 1 1
3b.	<p><u>Socio-economic challenges</u> <u>Limitations of health care</u> Challenge due to the ability of malaria parasites able to develop resistance to anti-malarial drugs</p> <p>Resistance to drugs is caused by incompletely treating an infected person and thus causes some of the surviving parasites to develop resistance to drugs, thus causing challenges in managing the spread of malaria</p> <p>For example, in 2009, resistance to anti-malarial drugs was observed along the Thai-Cambodia border</p>	4		

Population movement due to efficient transport and communications

Malaria Control programmes become ineffective because it is difficult to monitor the movement of people and increasingly even more difficult because movement is in larger volume and scale due to better and cheaper transport link

Border control is essential in places such as Greater Mekong subregion in SEA to control the spread of drug-resistant malaria across borders. This is because **malaria spread through uncontrolled migration and lack of coordination** between countries and this often led to malaria being transported to relatively low transmission areas, thus **causing challenges in managing the spread of malaria**

Travel advisories issued by governments to reduce travel to places where the risk of infection is very high. However, travel advisor may not be able to reach everyone especially those who do not have access to news and those who are illiterate, thus **causing challenges in managing the spread of malaria**

Environmental challenges

Climate

Changes in temperature and amount of rainfall affect the behavior and range of mosquitoes

Increased temperatures can cause mosquitoes to breed and mature faster and **increased rainfall** also provides more pools of standing water for mosquitoes to breed

These suitable conditions have **lengthened the period** in which mosquitoes can breed and transmit malaria

The result is a **greater frequency of malaria infection** and thus **causing challenges in managing the spread of malaria**

Monsoons

Monsoons bring high rainfall during the wet season and this helps to increase the number of malaria cases in India

In urban areas, heavy rains create long-lasting pools

	<p>of stagnant water for mosquitoes to breed and transmit malaria to the urban population, thus</p> <p>the spread of malaria</p>		
3c.	<p><u>Describe trend</u> Both DCs and LDCs experienced increasing trend in average food consumption from 1965 to 2015</p> <p>DCs have a higher average food consumption kilocalories per person per day than LDCs</p> <p>LDCs have a faster increasing rate in average food consumption kilocalories per person per day than DCs 2m more for data – total of 4m</p> <p><u>Explain trend</u> Higher income for DCs thus higher food consumption as compared to LDCs</p> <p>More people in LDCs have higher income thus they have an increasing rate of food consumption than DCs</p>	1 OR 1 OR 1	
3d.	<p><u>People</u> People suffer from obesity and other illnesses related to excessive food consumption include kidney, liver diseases and hypertension and can lead to health problems such as high blood pressure, coronary heart disease, diabetes and certain cancers</p> <p><u>Economy</u> Employees' inability to work as productively as before and who are absent from work due to sickness may cost companies millions in productivity and insurance costs</p> <p>Lower productivity also causes lower production of goods and services which reduces revenue due to lower exports</p> <p>Public health costs incurred thus more funds diverted to cater to the needs of treating obesity-related health thus less funds available for other developments thus progress of country can decline</p>	1 1 1 1 1 1	

3e.	<p><u>Increase food production</u></p> <p><u>High-yielding varieties</u></p> <ul style="list-style-type: none"> • Exhibit favourable characteristics like increased resistance to pest and diseases or the ability to grow within a shorter growing season, thus having more harvests and increase food production • For example, 'Wonder Rice' has a growing season of 100 days as compared to the growth duration of 120 days of the non-HYVs varieties, thus this helps to increase the intensity of food production <p><u>Fertilizers</u></p> <ul style="list-style-type: none"> • As farmlands are often not given the chance to fallow to regain its fertility, the application of fertilizers will help bring nutrients back to the soil, thus increasing food production <p><u>Pesticides and herbicides</u></p> <ul style="list-style-type: none"> • Pesticides are used to kill insects and small animals that destroy crops • Herbicides are used to kill weeds and other undesirable plants that compete with the food crops for nutrients • With the removal of pests, the crops are protected which in turn would increase the crop yield <p><u>Irrigation (supply of water)</u></p> <ul style="list-style-type: none"> • By supplying water to arid lands, irrigation has increased the amount of arable land for farming • For example, the Great Man-made River has made it possible to grow crops in the Sahara Desert • Water is also channeled to the coastal cities of Libya for domestic, industrial use and agriculture, helping to increase food production <p><u>Cannot increase food production</u></p> <p><u>Waterlogging</u></p> <ul style="list-style-type: none"> • Extensive irrigation can cause the ground to be waterlogged • Waterlogging occurs when too much water seeps into the soil and causes the soil to be oversaturated with water • This causes the roots to be deprived of air and nutrients that the crops need, eventually causing them to die 		
-----	--	--	--

	<ul style="list-style-type: none"> • This could lead a reduction in food production <p><u>Salinization</u></p> <ul style="list-style-type: none"> • Salinization occurs when water added to the soil during irrigation evaporates, causing salt to be left behind on the soil after evaporation • Excessive irrigation combined with inadequate drainage system, could also raise the level of the groundwater and bring salt particles closer to the surface • The groundwater may reach the upper soil layers, bringing up dissolved salts from the ground (capillary effect, or the upward movement of saline (salty) moisture through the fine spaces between the soil particles) • Saline soils could reduce the ability of crops to absorb water through their roots • The salt also inhibits (discourages) the ability of crops to transpire causing them to die thus reducing food production <p><u>Eutrophication</u></p> <ul style="list-style-type: none"> • Overuse of chemical fertilizers and pesticides causes chemicals to become concentrated on the soil and water, contaminating the ground water. • chemicals will seep into the soil and find their way to streams and rivers. • They become nutrients for the algae to grow, leading to eutrophication. • When the algae cover the water surface, they block sunlight from reaching the aquatic plants, causing them to die. • As a result, fishes feeding on aquatic plants will also die. • The Decomposition of the aquatic plants and animals depletes the oxygen in the water <ul style="list-style-type: none"> • Pollution from sewers in villages, towns and cities can contribute to the increase of nutrients in rivers and lakes, causing eutrophication, thus less water for irrigation and this causes reduction in food production 		8
4a.	<p>Mosquito takes blood from an infected person and becomes an infected mosquito</p> <p>Infected mosquito bites another human and the parasites are injected and migrated to the liver</p>	1	1

	<p>where they can reproduce and spread into the bloodstream</p> <p>Second mosquito bites the infected person and becomes infected and goes on to bite another person</p>	1	
4b.	<p>Fig. 9 – Stagnant pool of water Poor drainage of water creates conditions favourable for the growth of mosquito populations, thus contributing to the spread of malaria</p> <p>Fig. 10 – Overcrowded living conditions People live closely together in a small area and interact with one another more often, thus malaria spread quickly and easily</p>	1 1 1 1	
4c.	<p><u>Orphan crisis</u> Large numbers of children lose their parents due to HIV/AIDS</p> <p>Carers of the orphans are plagued by deeper poverty due to the medical costs and living expenses incurred when the orphans stay with them</p> <p>Orphans without the support of adults are vulnerable to forced labour into sex industry and to recruit as child soldiers</p> <p><u>Cost of health care</u> Health care costs can be expensive cost for individuals and countries</p> <p>Costs can come in the form of treatment and research and also high health care expenditures by governments for treating complications from HIV/AIDS</p> <p>This large amount of money could have been spent on other public services such as roads, public transport systems, schools and sanitation in the country</p> <p><u>Loss of productivity</u></p> <ul style="list-style-type: none"> • HIV/AIDS slows economic growth through a shortage of skilled labour in the workforce • Illnesses also cause employees to be absent from work for long periods, resulting in reduced labour productivity • Lack of funds to build an effective education 	1 1 1 1 1 1	

	<p>system results in lower skilled workforce</p> <ul style="list-style-type: none"> This deters foreign investments and hindered economic growth 		
4d.	<p><u>Difficulties in HIV detection</u> No visible signs of the disease for most of the period of infection</p> <p>Infected people may continue with their normal behavior, potentially infecting many others and people with limited access to healthcare made people difficult to obtain HIV testing, thus causing challenges in managing the spread of HIV/AIDS</p> <p><u>Lifestyle choices</u> Difficulty in containing the spread of HIV/AIDS due to sexually active years at young age and using injection drugs</p> <p>Cultures can influence lifestyle choices and makes it difficult to manage the spread of HIV/AIDS and causing individuals to continue with risk-taking behaviour</p> <p><u>Social stigma leading to non-reporting of disease</u> Social stigma causes many people to stay away from being tested and receiving treatment, thus increasing the spread and making it difficult to contain the spread</p> <p>Social stigma made people with HIV/AIDS to infect their partners because they are silent about their condition and also not to stay on track with their antiretroviral therapy, thus causing challenges in managing the spread of HIV/AIDS</p> <p>Health professionals may also discriminate against HIV infected patients as they believe that it is a waste of valuable resources to treat them and they will also get infected with HIV while treating these patients</p> <p>When left untreated, people infected with HIV/AIDS may spread disease to others, thus causing challenges in managing the spread of HIV/AIDS</p> <p><u>High cost of antiretroviral therapy</u> Treatment is costly and unaffordable to many patients</p> <p>Although antiretroviral treatment is becoming</p>		

	<p>cheaper, it is still unaffordable because of other costs such as transport costs to the clinic and forgoing a day's earning to a clinic, thus challenges the road to</p> <p><u>Population movement across borders and along highways for work</u> Some populations such as truck drivers who work long hours and spend long hours away from their families, are associated with the spread of HIV/AIDS due to their high mobility</p> <p>Thus they are more prone to risk-taking behavior such as seeking the company of commercial sex workers, thus ad c ages in n</p>		
4e.	<p><u>Precautionary measure</u> Providing vaccinations against H1N1</p> <p>In 2009, Singapore began providing vaccination for its population against the H1N1 influenza virus before it emerged in the country</p> <p>More than 400 family clinics island-wide stocked with H1N1 vaccines to ensure that Singaporeans had ready access to medical assessment and prompt treatment for mild cases of H1N1</p> <p><u>Success</u> Singapore is in the process of <u>developing its own vaccine for H1N1</u></p> <p><u>In 2013, Singapore's first H1N1 flu vaccine has reached the first phase of clinical trials, this could help to reduce the spread of H1N1</u></p> <p><u>Limitations</u> Vaccinations take up to 2 weeks to take effect</p> <p><u>Individuals may choose not to receive vaccinations and risk being infected with influenza virus, thus unable to manage the spread of dengue effectively</u></p> <p><u>Mitigation measure</u> Control measures during the SARS outbreak in 2003</p> <p><u>Detecting and Isolating infected people in a dedicated hospital</u></p> <p><u>A dedicated private ambulance service was used to transport people suspected to be infected</u></p> <p><u>Prevented and controlled spread within hospitals by</u></p>		

<p>closely monitoring the health of staff and by restricting visitors</p> <p>Potential patients of the disease were subjected to home quarantine by law</p> <p>Success Government intervention was prompt following the early detection of the disease</p> <p>WHO medical officials praised Singapore's handling of the outbreak and <u>its prompt and open reporting of cases</u></p> <p>They <u>encouraged other countries to learn from Singapore's</u> handling of the SARS outbreak</p> <p>WHO medical officials said stringent measures taken by Singapore <u>has contained the spread of the disease</u></p> <p>Limitations</p> <p>Some patients displayed <u>symptoms not commonly</u> associated with SARS</p> <p>Some <u>patients did not show any signs of SARS until much later</u></p> <p>As a result, these patients <u>infected people</u> they came in contact with</p> <p>This made the detection and the disease harder to contain. <u>Thus unable to manage the spread of SARS</u></p>	8	
Total	21	29

Name: _____ () Class: _____



**AHMAD IBRAHIM SECONDARY SCHOOL
PRELIMINARY EXAMINATION 2017**

GEOGRAPHY

2236/01

Level: Sec 4 Express

Date: 15 August 2017

Duration: 1 hour 40 minutes

READ THESE INSTRUCTIONS FIRST

Write your name, index number and class on all the work you hand in.

Write in dark blue or black pen on both sides of the paper.

You may use an HB pencil for any diagrams or graphs.

Do not use staples, paper clips, highlighters, glue or correction fluid.

Section A

Answer Question 1.

Section B

Answer one question.

Section	Marks
A	25
B	25
Total	50

Write all answers on the writing papers provided.

Candidates should support their answers with the use of relevant examples.

At the end of the examination, fasten all your answers securely together.

The number of marks is given in brackets [] at the end of each question or part question.

Submit the Question Paper and answers **separately**.

This question paper consists of 8 printed pages.

Setter: Mr. Faizal Osman

[Turn over]

Section A

This question is compulsory.

- 1 A group of students were investigating the coast at Whitley Beach, Vanuatu. Fig. 1 shows the surroundings, as well as transect (X-Y), along which they carried out their fieldwork.

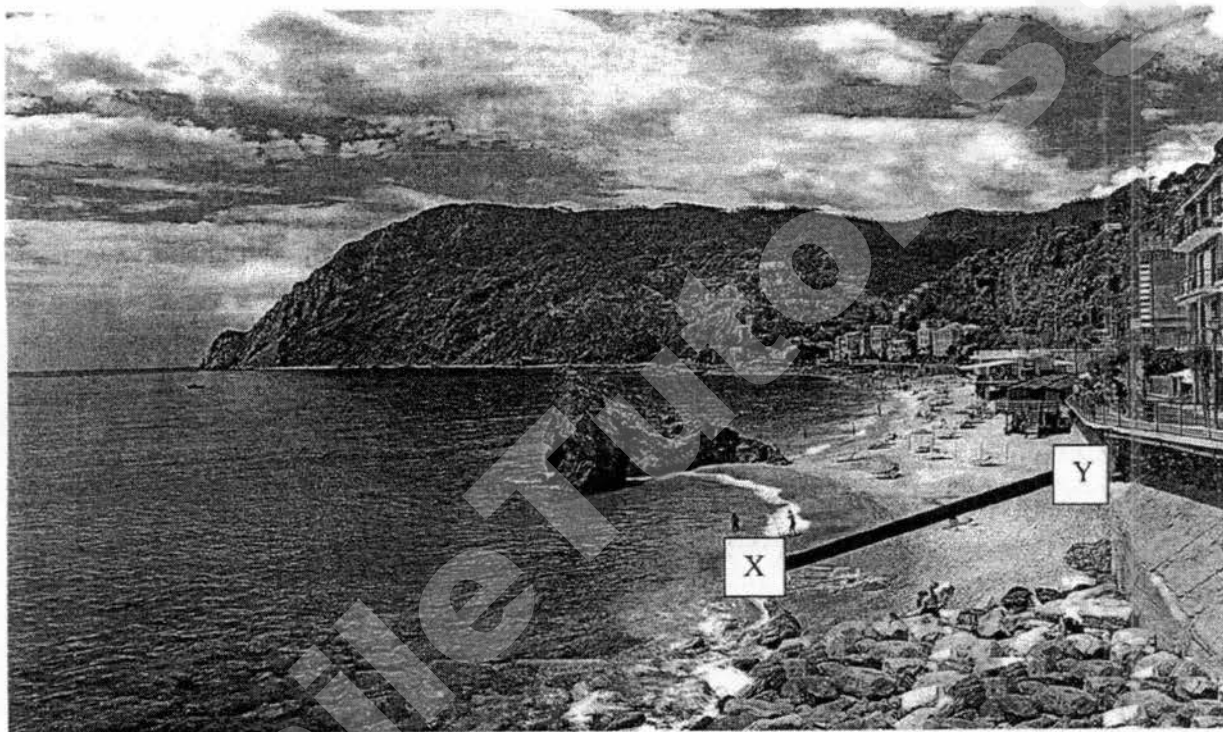

Fig.1

- (a) Draw a field sketch of the view shown in Fig. 1 using the blank paper provided. Annotate your sketch to identify and describe the coastal features shown.

[4]

- (b) The view of transect X-Y is shown in Fig.2 below. Students took sediment samples from four different sites, Q, R, S and T along the transect, as shown in Fig. 2. Fig. 3 and 4 show beach material found at sites Q and T in Fig. 2.



Fig. 2

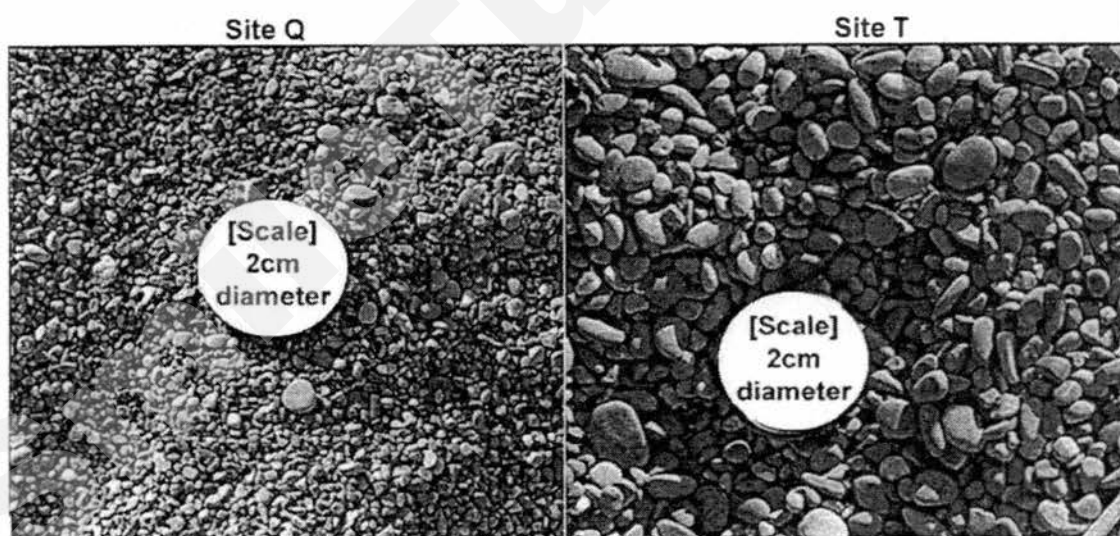

Fig. 3

Fig. 4

Compare the size of the beach materials at the two sites and suggest a hypothesis about the size of the beach material along the beach.

[2]

(c) They collected the data and presented it in Table 1 below.

Site	Distance from sea (m)	Diameter of sediments retained (mm) / Percentage of sediments (%)					
		0.0625	0.125	0.25	0.5	2	4
Q	0	20	40	20	10	5	5
R	5	30	25	20	10	10	5
S	10	35	20	20	10	10	5
T	15	5	5	10	15	20	45

Table 1

- (i) Describe how the data in Table 1 was collected at each site using a set of screen sieves. [4]
- (ii) From Table 1, identify the sampling method used by the students. Suggest an advantage of using this method. [2]
- (iii) What information would be needed the day before starting such a field investigation to ensure the safety of the students collecting the data? [2]
- (d) (i) Using the data in Table 1 and the graph paper provided, construct a comparative bar graph for Sites Q and T only. Your graph should show how the size of beach materials varies at these two sites. [3]
- (ii) What conclusions can the students draw from Table 1? [2]
- (e) Comment on the validity and reliability of the data in Table 1. You should evaluate the data collection strategy and suggest possible improvements. [6]

[Total: 25]

Section B

Answer one question from this section.

2 (a) Study Fig. 5 and 6 below, which show a stretch of coastline in Cape Town, South Africa.



Fig. 5



Fig. 6

- (i) Describe the coastline shown in Fig. 5. [3]
- (ii) With reference to Fig. 6, explain how the fragile nature of the coastline poses challenges for humans living in the area. [4]

- (b) Study Photograph A, which shows stilt houses in the sea in Kukup Island, Malaysia.



Photograph A

- With reference to Photograph A, explain how living along the coast provides advantages to the people of Kukup Island. [4]
- (c) Explain the conditions which favour the formation of beaches. [6]
- (d) "Restricting coastal development is the most effective method in the regulation and management of coastal areas."
To what extent do you agree with this statement? Support your answer with relevant examples. [8]

[Total: 25]

- 3 (a) Study Fig. 7 below, which illustrates the importance of global tourism to the world economy in 2014. Table 2 shows the growth in the number of tourism arrivals by region (ITA) as well as receipts from tourism by region (ITR) in 2014 compared with 2004 figures.

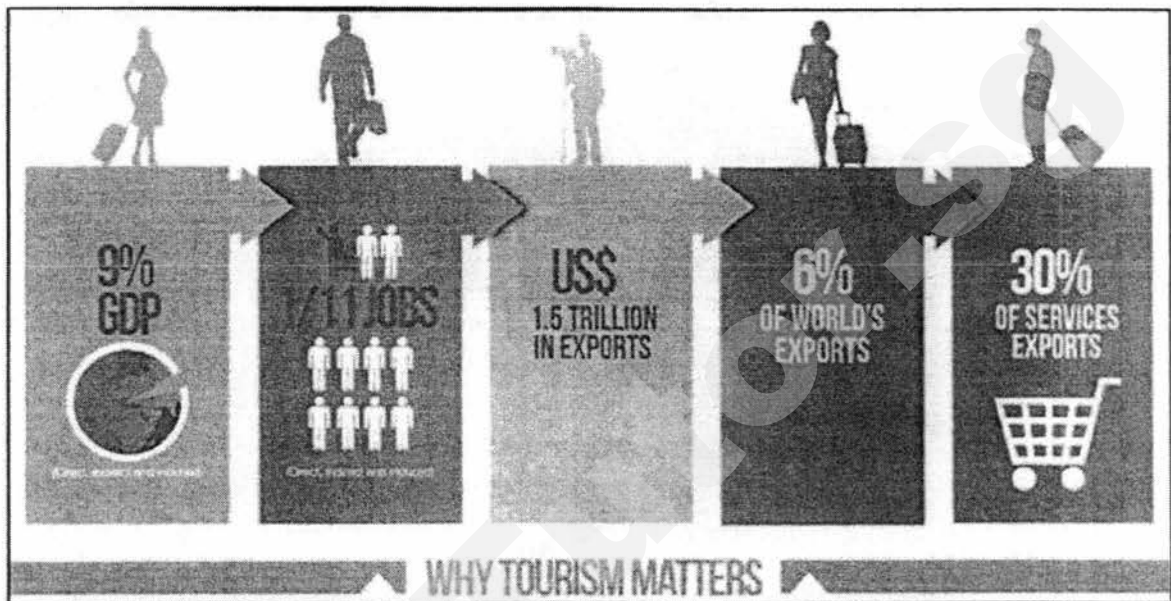

Fig.7

Region	International Tourism Arrivals (ITA)	International Tourism Receipts (ITR)
Americas (includes North and South America)	181 million (+16%)	US\$274 Billion (+22%)
Africa (excluding NE Africa)	56 million (+5%)	US\$36 Billion (+3%)
Europe (including Russia)	581 million (+51%)	US\$509 Billion (+49%)
Middle East (including NE Africa)	51 million (+5%)	US\$49 Billion (+4%)
Asia-Pacific (including Oceania & Pacific)	263 million (+23%)	US\$377 Billion (+30%)

Table 2

- (i) Based on the information in Fig. 7, explain the importance of tourism to the world's economies. [4]
- (ii) With reference to Table 2, describe the differences in international tourism arrivals and international tourism receipts in different parts of the world. [4]
- (iii) Account for the slower growth in regions like Africa and the Middle East compared to the rest of the world. [5]

- (b) Study Fig.8 that shows outbound leisure travelers over 65 years of age, by country, in Asia Pacific for 2011 and the predicted numbers in 2030.

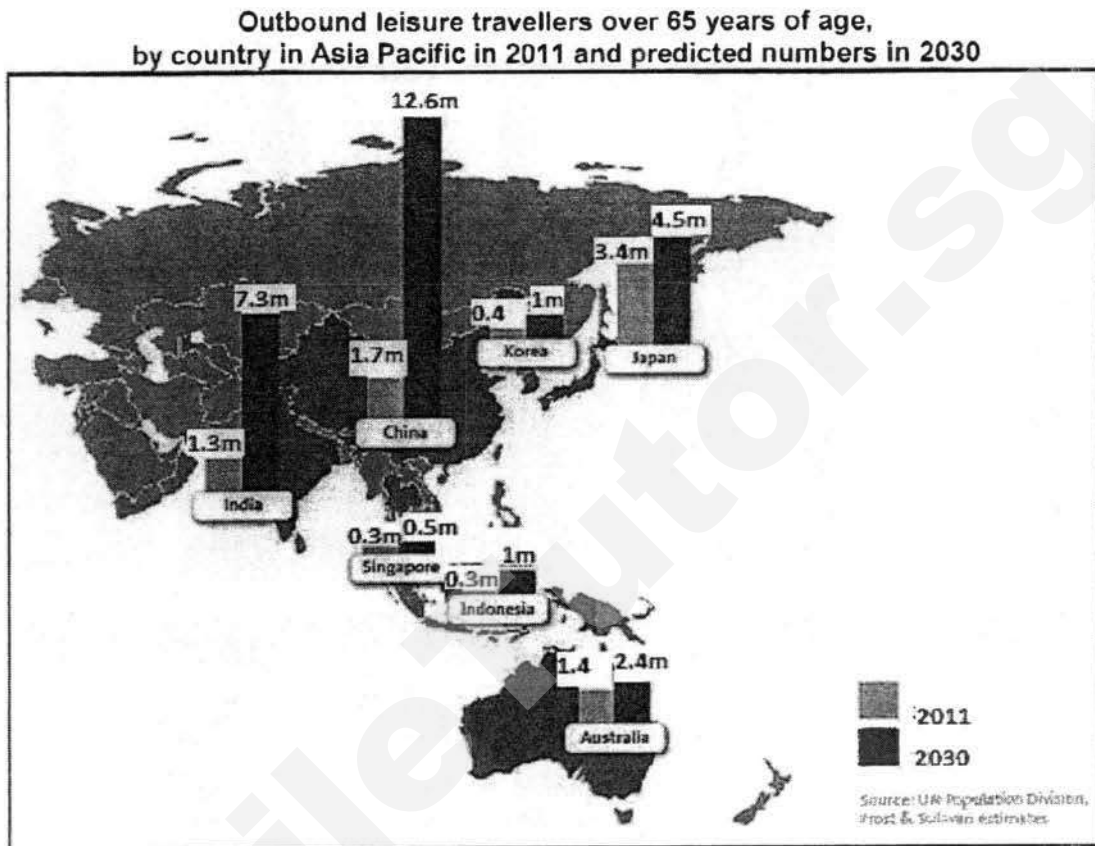

Fig. 8

With reference to Fig.8, compare the changes and suggest a reason for the predicted changes in the number of outbound leisure travelers over 65 years of age in Asia Pacific between 2011 and 2030. [4]

- (c) "Hard engineering methods are more effective than soft engineering methods in reducing coastal erosion." To what extent do you agree with this statement? Support your answer with relevant examples [8]

[Total: 25]

End of Paper

Name: _____ () Class: _____



**AHMAD IBRAHIM SECONDARY SCHOOL
PRELIMINARY EXAMINATION 2017**

**GEOGRAPHY
2236/02**

Level: Sec 4 Express

Date: 17 August 2017

Duration: 1 hour 30 minutes

READ THESE INSTRUCTIONS FIRST

Write your name, index number and class on all the work you hand in.

Write in dark blue or black pen on both sides of the paper.

You may use an HB pencil for any diagrams or graphs.

Do not use staples, paper clips, highlighters, glue or correction fluid.

Section AAnswer **one** question.**Section B**Answer **one** question.

Section	Marks
A	25
B	25
Total	50

Write all answers on the writing papers provided.

Candidates should support their answers with the use of relevant examples.

At the end of the examination, fasten all your answers securely together.

The number of marks is given in brackets [] at the end of each question or part question.

Submit the Question Paper and answers **separately**.

This question paper consists of 9 printed pages.

Setter: Mr. Faizal Osman

[Turn over]

Section A

Answer one question from this section.

Answer ALL questions.

1(a) Study Fig. 1 which shows a map of the world.

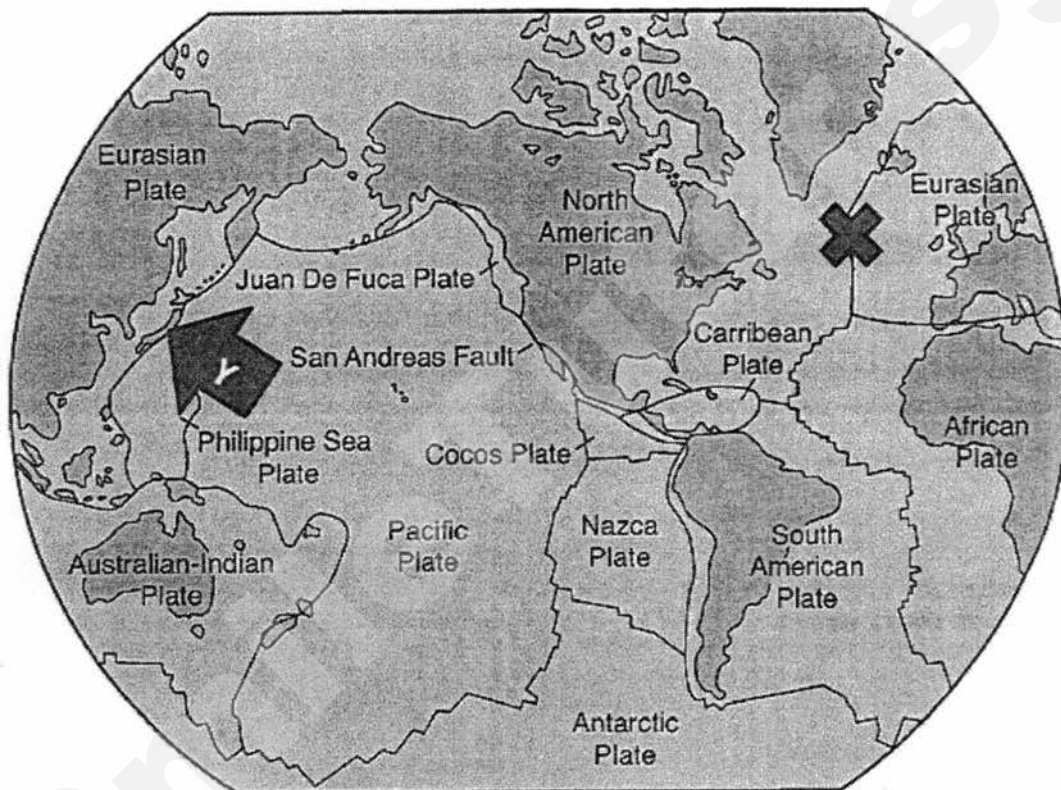

Fig. 1

X Mid-Atlantic Ridge

- (i) Using Fig.1, describe and account for the formation of the Mid-Atlantic Ridge. [4]
- (ii) Explain the presence of volcanoes in Country Y. [3]
- (iii) Using examples that you have studied, describe the advantages and disadvantages of living near volcanoes. [5]

- (b) Photographs A and B shows the effects and magnitude of earthquakes in Nepal, 2015.



Photograph A



Photograph B

Using the evidence from **Photograph A** and **B**, account for the severity of the impacts of the earthquake. [5]

- (c) "Preparedness measures are more important than long term responses to threats and impacts of earthquakes."
How far do you agree with the statement? Support your answer with relevant examples. [8]

[Total: 25]

- 2 (a) Fig. 2 shows the global land temperature readings and named volcanic eruptions from 1750 to 2000.

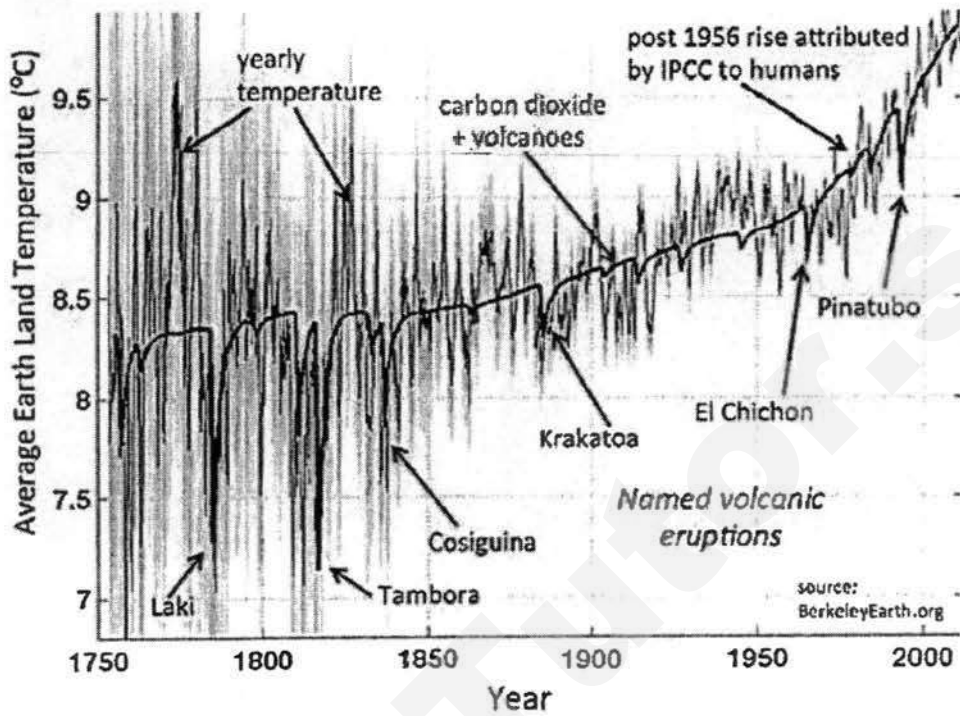

Fig.2

- (i) Describe the trend of the average surface temperature as shown in Fig.2. [4]
- (ii) Discuss the impacts of volcanic eruptions and human activities on global climate. [5]

- (b) Fig. 3 shows the pathway and seasons of tropical storms.

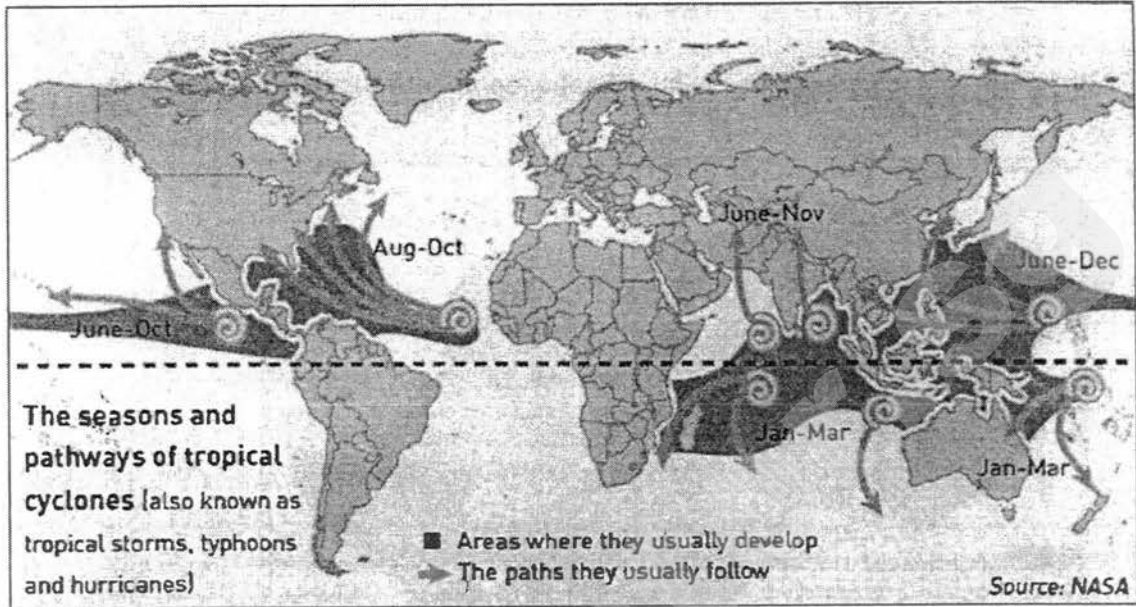

Fig.3

Account for the occurrence of tropical storms in the areas shown in Fig.3. [

- (c) Using named examples, discuss two possible impacts of tropical storms as shown in Fig. 3. [
- (d) "Floodplain management is the most effective in mitigating the impact of tropical storms." How far do you agree with the statement? Support your answer with relevant examples. [

[Total: 24,

Section B

Answer one question from this section.

3(a) Study Fig. 4 which shows the distribution of undernourished population in Africa.

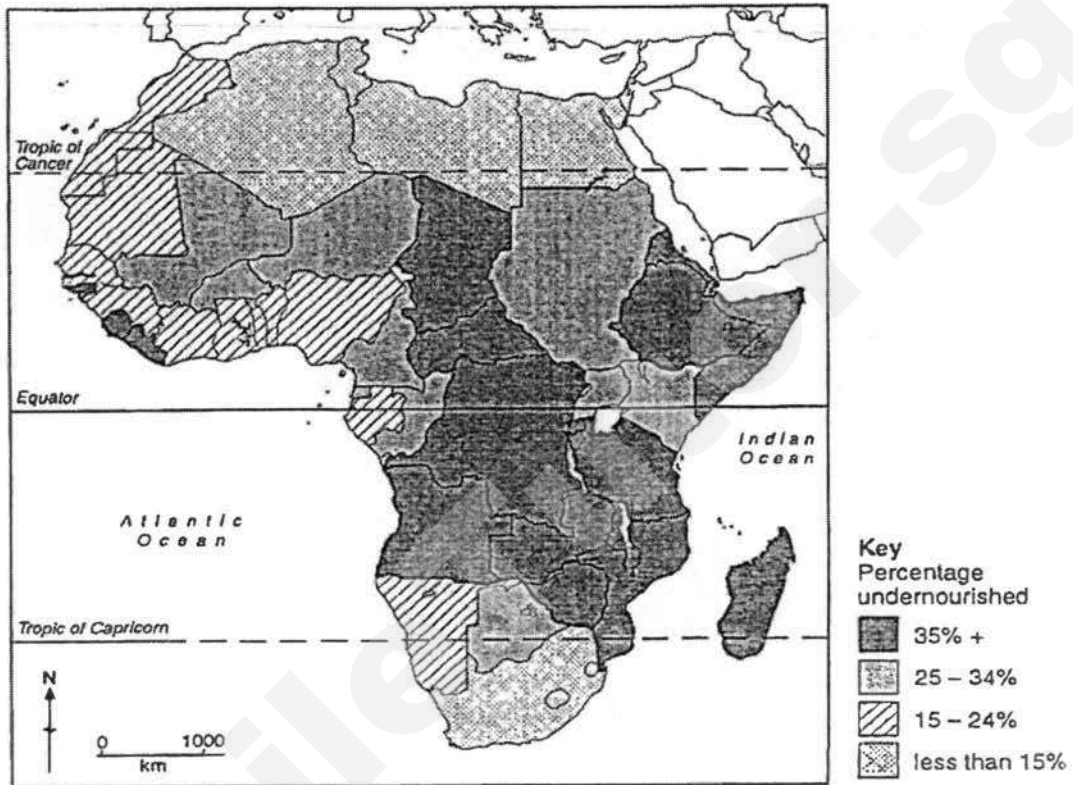

Fig. 4

Describe the pattern of undernourished population shown in Fig.4.

[4]

- (b) Fig 5 shows land transactions in Tanzania.

Tanzania, a hotspot for agrofuel investments

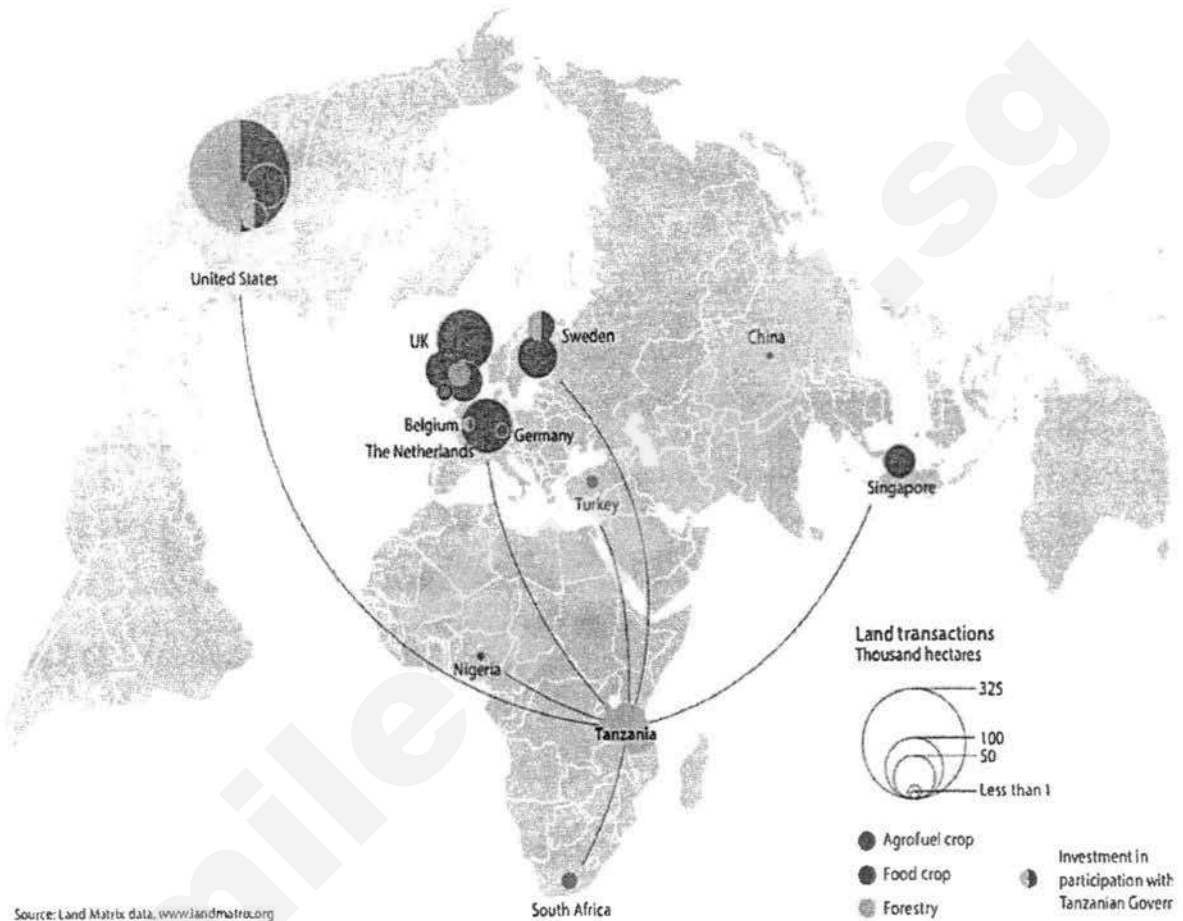

Fig.5

- b (i) Describe the distribution of countries with land transactions with Tanzania and the various ways they use the land. [4]
- (ii) Explain both the positive and negative impacts of selling or leasing land to another country for the purposes shown in Fig 5. [5]
- (c) With reference to Singapore, describe and explain what the government can do to ensure food safety and stability in a country. [4]
- (d) "Intensification of food production can have negative impacts on water and soil quality". How far do you agree with the statement? Support your answer with relevant examples. [8]

[Total: 25]

- 4 Study Fig. 6, which shows the distribution of HIV/AIDS in parts of Africa.

HIV/AIDS Rate in Sub-Saharan Africa

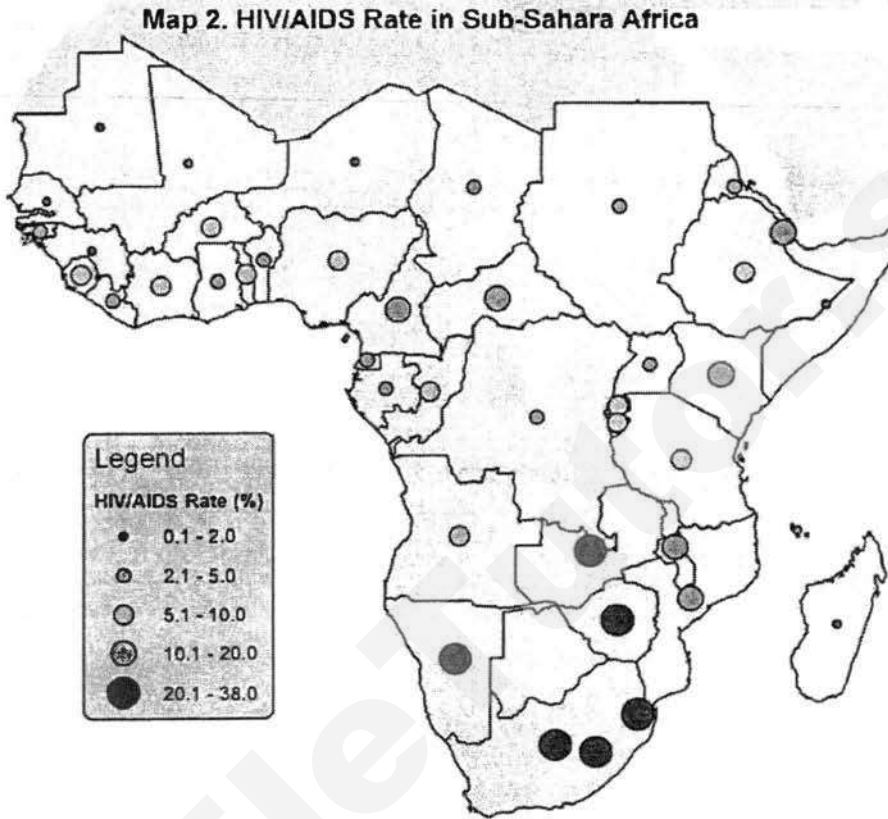

Fig.6

- (a) (i) Describe the distribution of the areas with more than 10% of HIV/AIDS infection rates. [3]
- (ii) Describe the socio-economic impacts of high HIV/AIDS infection rates in the region shown in Fig.6. [5]

ANSWER KEY

Section A

This question is compulsory.

1	A group of students were investigating the coast at Whitley Beach, Vanuatu. Fig. 1 shows the surroundings, as well as transect (X-Y), along which they carried out their fieldwork.	
(a)	<p>Draw a field sketch of the view shown in Fig. 1 using the blank paper provided. Annotate your sketch to identify and describe the coastal features shown.</p> <p>1m for field sketch title: Field sketch of Coastal Features shown in Fig.1 1m for accuracy in sketching: must show the shape and features of the coastline 1m for identification of at least 2 coastal features: spit, wave cut platform, cliff, arches, stack, stumps 1m for annotation: shoreline, beach, headland (must include at least 2 for 1 mark, no marks given if only 1 annotation)</p>	[4]
(b)	The view of transect X-Y is shown in Fig.2 below. Students took sediment samples from four different sites, Q, R, S and T along the transect, as shown in Fig. 2. Figs. 3 and 4 show beach material found at sites Q and T in Fig. 2.	
	<p>Compare the size of the beach material at the two sites and suggest a hypothesis about the size of the beach material along the beach.</p> <ul style="list-style-type: none"> • Sediment size is larger at Site T than at Site Q (or sediment size is smaller at Site Q than Site T).(1) • Sediments at both sites are mostly much smaller than 2cm. (1) • Hypothesis: The further up the beach from the sea, the larger the sediment size (or vice versa) (1) <p><i>1 mark each for description for a maximum of 2m.</i></p>	[2]
(c)	They collected the data and presented it in Fig. 5 below.	

Site	Distance from sea (m)	Diameter of sediments retained (mm) / Percentage of sediments (%)					
		0.0625	0.125	0.25	0.5	2	4
Q	0	20	40	20	10	5	5
R	5	30	25	20	10	10	5
S	10	35	20	20	10	10	5
T	15	5	5	10	15	20	45

Fig. 5

	(i)	<p>Describe how the data in Fig. 5 was collected at each site using a set of screen sieves.</p> <ul style="list-style-type: none"> • Use a set of screen sieves (with netting of different sizes) that is <u>arranged with largest holed-netting on top and finest at the bottom.</u> • Ensure sediments collected are <u>dry, or dried.</u> • Collect a <u>fixed amount</u> of sediment (e.g. 1 cup or 100g) from a site. • <u>Pour</u> sediments into the top sieve and <u>shake</u> the entire screen sieve so that the sediments pass through different layers and are sorted into different sizes. • <u>Weigh</u> the amount of sediment in each sieve layer and <u>calculate</u> the % of sediments of different sizes. <p><i>1 mark each for description for a maximum of 4m.</i></p>	[4]
	(ii)	<p>From Fig. 5, identify the sampling method used by the students. Suggest an advantage of using this method.</p> <ul style="list-style-type: none"> • Systematic sampling • This ensures that the transect will be <u>evenly sampled at regular intervals</u> as compared to using random sampling or it is <u>free from human bias.</u> <p><i>1 mark each for description for a maximum of 2m.</i></p>	[2]
	(iii)	<p>What information would be needed the day before starting such a field investigation to ensure the safety of the students collecting the data?</p> <ul style="list-style-type: none"> • Tide times (times of high/low tide) • Wind conditions/size of waves (check that the size of waves are not too large and are suitable for conducting fieldwork safely) • Weather conditions (too cold, too hot or too wet for fieldwork) • Any other information related to safety • <i>X Check for broken glass etc, check for tsunami</i> 	[2]

1 mark each for description for a maximum of 2.

- (d) (i) Using the data in Fig. 5 and the graph paper provided, construct a comparative bar graph for Sites Q and T only. Your graph should show how the size of beach materials varies at these two sites. [3]

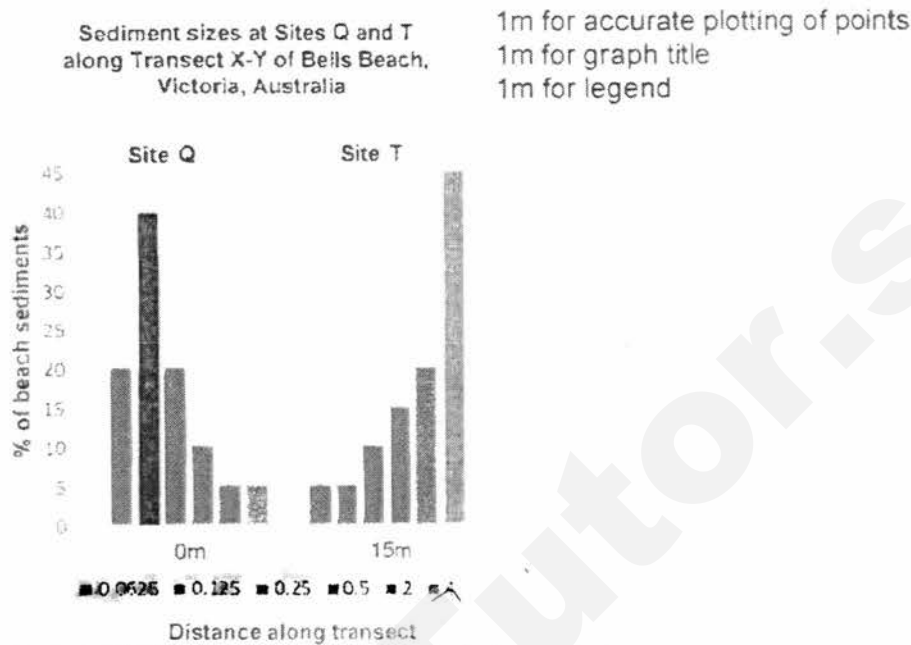

- (ii) What conclusions can the students draw from Fig. 5? [2]

- The further the distance from sea, the bigger the sediment size. [1]
- *[Example of use of data]*- at 0m from the sea, 60% of the sediments were smaller than 0.25mm. While at 15m from the sea, 45% of the sediments were bigger than 2mm. [1]

Any of the above points (overall statement, examples or identification of anomaly), 1 mark each. For mark to be awarded for example, ensure that data cited is accurate.

- (e) Suggest how valid and reliable the data in Fig. 5 is. You should evaluate the data collection strategy and suggest possible improvements. [6]

Validity/Reliability

- From the anomaly (Site S at 10m from the sea), data observed by the students may have been influenced by human activities and not a result of natural sorting by wave action.
- The students only collected the data on 1 day.

However, the data was also valid/reliable because:

- Measurements were taken at regular intervals along the line of transect i.e. every

5m

Improvements

- Students should select a part of the beach that is not affected by human activities.
- They could conduct the investigation for a longer period of time (e.g. 3 days)
- They should conduct the investigation at more parts of the beach.
- *Reduce interval where samples were taken from 5m to 2m for e.g.*

1 mark each for any reason, elaboration on why this would affect validity/reliability or improvement. If no explanations of validity/reliability or suggestions for improvements – max 3 marks.

Section B

Answer one question from this section.

2 (a)	Study Figs. 6 and 7 below, which shows a stretch of coastline in Cape Town, South Africa.	[4]
(i)	<p>Describe the coastline shown in Fig. 6.</p> <ul style="list-style-type: none"> • Steep coastal cliff/escarpment • Jagged/ rocky cliff face • Presence of horizontal rock joints at base of cliff • Some rocks/ rubble at base of cliff • Gently sloping beach at base of cliff with sand deposits • Signs of mass movement, landslides, erosion <p><i>1 mark each for description, up to 3 marks</i></p>	[3]
(ii)	<p>With reference to Fig. 7, explain how the fragile nature of the coastline poses challenges for humans living in the area.</p> <p>Evidence from Fig. 7</p> <ul style="list-style-type: none"> • Road/footpath eroded, damaged and cut off makes access difficult for the people living in the area/require alternative access transport routes to be developed • Houses, buildings and other property near the cliff may be damaged as the cliff continues to slump and retreat backwards householders may suffer economic losses/be rendered homeless • Fences to property may be destroyed in parts where they collapse together with the eroded cliff pose security risk to homeowners • Exposure of underground service lines such as electricity/telephone/water damage of communications/electricity/water supplies which will disrupt the domestic and other activities of the people living there • Exposure of underground service lines such as electricity/ telephone/water requires maintenance/replacement cost <p><i>Award 1 mark per point of suggestion explained, up to a maximum of 4 marks. If no photographic evidence is provided, cap at 2 marks. Not accepted → (Living near at or near the coast, a tsunami will affect the residents and result in the loss of lives) Candidates are to note that the threat of tsunami is ever-present when one decides to make the coast his/her place of residence.</i></p>	[4]

(b)	With reference to Photograph A, explain how living along the coast provide advantages to the people of Kukup Island.	[4]
	<p>The nutrients from the sea provide food for the development of fisheries/aquaculture; Which in turn provide employment/source of livelihood to the people living on Kukup Island;</p> <p>The aquaculture in turn attracts tourists who want to enjoy the fresh seafood; Which in turn provide income and employment to the people living on Kukup Island</p> <p>Living next to the sea makes transportation convenient As the water allows for the use of boat services to ferry the people around</p> <p>Living next to the sea makes it convenient for the people to dispose of their waste; As the water transports their waste away</p> <p><i>Award 1 mark per point of suggestion explained, up to a maximum of 4 marks. If no evidence from photograph is provided, cap at 2 marks.</i></p>	
(c)	<p>Explain the conditions which favour the formation of beaches.</p> <p>Beaches form in sheltered bays/areas where the reduction of energy will lead to deposition;</p> <p>As the waves enters the sheltered areas it experiences refraction and dissipates wave energy thus leading to more loss of energy</p> <p>Presence of gently sloping coast that allows waves to break gently on the coast thus depositing the load that the waves carry;</p> <p>The reduction of energy will create constructive waves which have more swash than backwash which will lead to deposition of materials on the beach;</p> <p>Abundant material is available for example, where longshore drift brings in abundant material from various sources like cliffs and headlands.</p> <p>The areas of beach formation must not be exposed to strong winds, storms and typhoons that will carry the sediments away thus retarding beach formation.</p> <p><i>Credit points of explanation at one mark each</i></p>	[6]

(d)	<p>'Restricting coastal development is the most effective method in the regulation and management of coastal areas.'</p> <p>How far do you agree with this statement? Use examples to support your answer.</p>	[8]
<p style="text-align: center;"><u>***coastal protection strategies are not accepted***</u></p> <p>This is because the question asks specifically for regulation and management of coastal areas.</p> <p><u>Restrict development in areas prone to natural hazards</u></p> <p>Restricting development involves implementing laws and policies that involve relocation of built structures away from areas prone to natural hazards. In future planning of uninhabited coastal areas, risks are also calculated and new structures are being built away from coasts to mitigate the disastrous impacts brought about by natural hazards. Natural coastal hazards, such as tsunamis are disastrous to natural environments and human activities. The earthquake in Tohoku, Japan, in 2011 for example brought about a huge tsunami that caused the death of 20,000 people and US\$300 billion losses. Government bodies, therefore, research on how severe or widespread the problem is, plan for it, then make and enforce laws. In USA, for example, the Federal Emergency Management Agency (FEMA) steers development away from areas prone to flooding or coastal erosion, by relocating current buildings away. Another method is avoidance, where developments are being regulated and restricted from being established on low-lying lands.</p> <p>However, this method has its limitations. People are still attracted to coasts despite the occurrence and unpredictability of natural hazards, as coasts provide natural resources and built services, such as docks, ports, etc. Therefore, there is a limit to how effective restrictions are, as some people may still continue to stay in areas where it has been cordoned off. Residents and investors of coastal areas may have to spend more in construction and maintenance, and will also need to be prepared for emergencies.</p> <p><u>Protection of coastal resources</u></p> <p>A strategy to prevent sources from being exploited or depleted. Fish is an example of what needs to be protected and areas close to the coastline where around 90% of all marine fish are caught are vulnerable to overfishing. This is especially seen in areas where destructive fishing methods of blasting and poison fishing are used in the coral reef areas.</p> <p>In both Wakatobi National Park in Indonesia and Goat Island Marine Reserve in New Zealand, zones have been marked off to prevent commercial fishing. This is done through local management or establishment of a marine reserve. Marine reserves protect marine ecosystems which allow fish and endangered species to breed and thrive.</p> <p>The Goat Island Marine Reserve is now a tourist attraction because of its plentiful fish;</p>		

there are now up to 14 times more snappers within the reserve than outside it. This demonstrates the positive management impact of protecting coastal resources.

However, the establishment of marine reserves is often strongly opposed by local fishermen. Their access to a valuable resource and possibly a source of food, is now being denied. The potential long-term benefits of a marine reserve may not be significant to locals who can no longer fish in an area that has supported them for a long time.

Limit damaging activities

These refer to activities that interrupt the functioning of natural systems. Some of these activities include blasting coral reefs to create a channel for boats, clearing mangroves to develop fish farms, dumping waste into coastal areas or into seas, and constructing facilities such as docks and marinas that replace the natural features of the coast.

As banning these damaging activities might be costly and inefficient, many national and local governments instead try to limit these activities. This is done through management that aligns the needs and demands of the people together with the nature of the coastal environment.

Sand dunes, which are deposits of windblown sand from the foreshore zone stabilized by plants, were often trampled on by people visiting the beach in Port Philip. Dune vegetation was being destroyed and the sand dunes were left exposed to wind erosion. Houses behind the dunes were in danger of being partly buried by the large volumes of sand blown by the wind.

To allow the dunes to recover, authorities fenced off the dunes and built access paths to the beach. This decision allowed the coastal environment to recover. However, these fences make the beach look less attractive and do not allow visitors and residents access to all parts of the beach.

Level 1 (0-3m)

Generally addresses restricting coastal development only
 Poor description of management strategy
 No or poor evaluation of the management strategy
 No example given

Level 2 (4-6m)

Addresses at least restriction of coastal development and 1 other management strategy
 Or coastal protection measures (e.g. seawall and planting of mangroves)
 Some description of the management strategy
 Satisfactory evaluation of the management strategy
 At least one example given

Level 3 (7-8m)

Addresses at least restriction of development and 2 other management strategies
 Clear description of management strategies

Thorough evaluation of impact management strategies At least one example given for each strategy	
---	--

3 (a)	Study Fig. 8 below, which illustrates the importance of global tourism to the world economy in 2014. Table 1 shows the growth in the number of tourism arrivals by region (ITA) as well as receipts from tourism by region (ITR) in 2014 compared with 2004 figures.	
-------	--	--

(i)	Based on the information in Fig. 8, explain the importance of tourism to the world's economies.	[4]
-----	---	-----

Information from Fig. 8 indicates that tourism is very important to the world's economies; the data indicates that:

Tourism accounts for 9% of the world's total GDP – this shows that many of the world's economies/countries depend on tourism for revenue

Fig. 8 also indicates that tourism alone accounts for as many as 1/11 of all jobs in the world either directly, indirectly or linked – this shows that without tourism, unemployment numbers in many parts of the world will be much higher

Fig. 8 also indicates that tourism and related industries together accounts for US\$1.5 trillion in exports – this shows that to service the tourism industries, exports of materials and services help to generate not only business for economies and industries but is also important for world trade and development

As Fig. 8 indicates, tourism alone accounts for 6% of the world's exports – this is achieved through export of resources as needed by the tourism industry either directly e.g. food resources, building materials or indirectly e.g. transport, electricity and infrastructure materials needed to build tourism-related services and activities

The tourism also accounts for as much as 30% of all services exported – this is due to the need for transport as well as travel-related services that are required to serve the tourism industry – this indicates that the tourism industry is a major service industry for the world economy.

Overall, this shows that the tourism industry is a key player in the world's economy.

4 @ 1m each; answers shd not only repeat points showed in Fig. 4 but also elaborate/explain how this is important to the world's economy.

Award max. of 2m for answers that simply repeat points/ideas from Fig. 4 with link to show how it is important to the world's economies.

Award max. 2m if no data is provided in support of reasons.

(ii)	With reference to Table 1, describe the differences in international tourism arrivals and international tourism receipts in different parts of the world.	[4]
	<p>Table 1 indicates that most of the tourist arrivals in the world go to Europe – this is shown by Table 3 which shows that Europe alone accounts for more than half of the total arrivals at 581 million.</p> <p>This is compared with the rest of the world which accounts for only 551 mill of international tourist arrivals (ITA)</p> <p>Europe also accounts for the largest proportion of tourism receipts at US\$509 bill followed by the Asia-Pacific region at US\$377 bill</p> <p>Comparatively, Africa and the Middle East account for the smallest numbers of ITA at 55 mill and 51 mill respectively;</p> <p>They also account for the smallest in terms of ITR at US \$34 bill and US\$49 bill respectively</p> <p>In terms of the rate of growth of ITA, Europe experiences the highest rate at 51%, followed by the Asia-Pacific Region (+23%) and the Americas (+16%).</p> <p>This is compared with only 5% for Africa and the Middle East regions. This is compared with only 5% for Africa and the Middle East regions.</p> <p>4 @ 1m each with explanation/ elaboration;</p> <p>Award max. of 2m if there is no reference to Table 1. Award max. 2m if no comparison is made in ITA/ITR between the different regions.</p>	
(iii)	Account for the slower growth in regions like Africa and the Middle East compared to the rest of the world.	[5]
	<p>The reason for this is due to factors like disposable income– developed regions have a higher disposable income so the highest numbers go to Europe, while the Americas also account for a fairly large number.</p> <p>Award 1 marks for stating disposable and 1 mark for explaining it using the DC vs LDC (level of disposable income) framework.</p> <p>Another possible reason is that Africa is fairly undeveloped in terms of infrastructure compared with other parts of the world – this also includes poor infrastructure such as airports or other transport infrastructure, hotels for tourists or services such as water and electricity.</p>	

	<p>Award 1 marks for stating factor and 1 mark for explaining it using the DC vs LDC (infrastructural development) framework.</p> <p>This would be a discouraging factor for tourists who may be interested in visiting Africa. This would have led to smaller numbers visiting Africa (ITA) as well as smaller receipts due to the smaller ITA and lack of services/activities that serve the tourism industry in Africa and the Middle East.</p> <p>Award 1 mark for further explanation it using the DC vs LDC (infrastructural development) framework.</p>	
(b)	<p>Study Fig. 9 that shows outbound leisure travellers over 65 years of age, by country in Asia Pacific up to 2030. With reference to Fig. 9, compare the changes and suggest a reason for the changes in outbound leisure travellers over 65 years of age in Asia Pacific between 2011 and 2030.</p>	[4]
	<p>Increasing trend across Asia Pacific countries.(1) Largest increase is in China with 640% and least increase is in Japan with 32%. (1)</p> <p>Max 2m for comparison of changes. Must include data from source for marks.</p> <p>Reasons: Growing affluence – especially for the rising economy like china where they are better-off would choose to travel. Retirees also have more resources to travel. Changing lifestyle – more elderly who are healthier than their predecessors travel more after retirement.</p> <p>2 m for stating one reason with explanation.</p>	
(c)	<p>"Hard engineering methods are more effective than soft engineering methods in reducing coastal erosion." To what extent do you agree with this statement?</p>	[8]
	<p>Soft Engineering</p> <p><u>Stabilising coastal dunes</u> -A coastal dune acts as barriers along the coast protecting human property such as houses and roads against coastal erosion and flooding from waves Limitations: -Vegetation cannot totally prevent soil erosion -For long term solution, human activities such as property development and recreational activities should be kept to the minimum</p> <p><u>Planting mangroves along the shores</u> -Mangrove have prop roots or kneed roots that anchor the trees firmly in muddy soil -The roots bind the loose soil and protect it from erosion The roots bind the loose soil and protect it from erosion Limitations: -Young mangroves are fragile, local people must cooperate by not letting young animals graze on them</p>	

Beach nourishment

-Where beach erosion has become a major problem, a method of beach replenishment is used, involving the adding of sand, brought in from an external source to the badly eroded beach

Limitations:

- last only for about 10 years
- cost is extremely high
- regular maintenance is required
- e.g. In 2005, 24 km of Miami Beach, USA cost US\$64 m

Encouraging growth of coral reefs:

It has several positive impacts and it is an important resource to the marine ecosystem. It reduces the impact of wave energy from the sea. It also is an important ecosystem for the creatures of the sea. It is relatively cheap as it is a self-sustaining if left untouched by human activities.

Limitations:

- Depends on cooperation of various groups of people including fisherman, industries and government bodies
- Take a very long time to proliferate and it is fragile and is prone to destruction

Breakwater

- Breakwaters help break the force of oncoming waves
- Built either parallel to the coast or with one end attached to the coast
- When constructed offshore, breakwaters can create a zone of calm water behind them
- Materials are deposited and build up in this zone of calm water

However,

- Aesthetically unappealing
- Costly to build and maintain
- Protect the coast unevenly as materials away from the breakwater are subjected to wave action and possible erosion
- Examples:
 - Along the reclaimed shorelines of East Coast Park in Singapore
 - Siloso Beach in Sentosa Island in Singapore
 - Portland Harbour, England
 - Almeria, Spain

Seawall

- Usually made of concrete, granite or stone
- Build along/parallel to the coast
- To protect the coastlines against wave attack by absorbing the wave energy
- Protect against strong waves especially during storm

However,

- Waves energy is directed/reflected towards the base of the seawall

- Resulting in undermining which wears away the base of the seawall
- Causing it to weaken thus collapse over time

Examples:

- Along the coast of Drakes island in England
- Pathway on the seawall, which has been extended far outside the boundaries of Stanley Park has become one of the most-used features of the park by both locals and tourists.

Candidate at each level will show the following characteristics:

Level 1 [0 – 3 marks]

- No reference to named example(s).
- Answer limited to descriptions of strategies only.
- No evaluation OR one-sided evaluation of strategies only.

Level 2 [4 – 6 marks]

- Clear explanation of how strategies help to reduce erosion
- At least ONE balanced discussion of a strategy.
- Good use of example in the answer
- May attempt to evaluate between the different type of strategies
- Reference to named example(s)

Level 3 [7-8 marks]

- Clear explanation of how both strategies help to reduce erosion.
- Balanced discussions of all strategies and explains relative importance of the discussed strategies i.e. not just why they are effective/ineffective, but explains why one is more, and the others less effective.
- Excellent use of examples in the answers provided.

Answers

Section A [25marks]		
1	a	Study Fig. 1 which shows a map of the world.
	i	Using Fig.1, describe and account for the formation of the Mid-Atlantic Ridge. [4]
		<ul style="list-style-type: none"> • 2 oceanic plates, N.America & European plates move from each other at the divergent plate boundaries. • Creates cracks/faults between the plates • Magma rises through the cracks, cools and solidifies. Forming new crust. (Sea-floor spreading) • Mid-Oceanic ridges are then formed to the the sea-floor spreading the the build up of magma at the cracks/fault lines. • 4 points @ 1 mark each
	ii	Explain the presence of volcanoes in country Y. [3]
		<ul style="list-style-type: none"> • Even at the divergent plate boundaries there are cracks and faults allowing for magma to flow (possible of using terms like vent and pipes) during the plate divergence. • They will then be able to reach the earth's surface and form a layer of lava which cools and solidify. • Many layers forming results in volcanoes after thousands of years. • 3 points @ 1 mark each.
	iii	Using examples that you have studied, describe the advantages and disadvantages of living near volcanoes.
		<p>Elaboration on each point is needed, including a named example.</p> <ul style="list-style-type: none"> • Advantages: Fertile volcanic soil (Japan, Java etc) • Precious stones and minerals, building materials (Java, Japan etc) • Tourism (Bali, Madagascar etc) • Geothermal energy.(Iceland, Japan, etc) • Example: An advantage is geothermal energy when groundwater comes into contact with hot rocks beneath the surface, it heats up and erupts as hot water or steam. The hot water or steam can be harnessed to drive turbines and produce electricity. [1 mark] • Disadvantages: Destruction by volcanic materials (Philippines, Italy etc) • Landslides (Japan, Java etc) • Pollution (Philippines, Indonesia, Iceland etc) • Effects on weather (Philippines, Indonesia, Iceland etc) • Example: A disadvantage is landslides where parts of the volcanic cone will collapse during an eruption, ranging from a few rock fragments to landslides of several hundreds of cubic kilometres. They will obstruct flow of rivers causing floods, blocked roads and buried villages and farmlands. • 5 points @ 1 mark each • 3 points on advantages and 2 points on disadvantages or vice versa

	b	Photograph A and B shows the effects of an earthquake in Nepal, 2015. Using the evidence from Photograph A, account for the severity of the impacts of the earthquake. [5]
		<p>Severity of impacts:</p> <ul style="list-style-type: none"> • Destruction of properties where many buildings crumbled and impossibly hard to live in. • With so many obstacles and communication lines dangling or snapped, there will be disruption of services. • Loss of lives and property <p>Max. 2 marks for describing the impacts in the Photograph.</p> <p>Reasons for the impacts:</p> <ul style="list-style-type: none"> • Distance from epicentre (near) thus the energy from the earthquake is more • Type of soil (Nepal is a mountainous region) thus causing landslides • Magnitude (high) • Population density (tourism & largest city in Nepal) <p>3 points @ 1 mark each</p>
	d	'Preparedness measures are more important than long term responses to threats and impacts of earthquakes.' How far do you agree with the statement? Give reasons for your answer. [8]

	Section A [25marks]	
2	a	Fig. 2 shows the global land temperature readings and named volcanic eruptions from 1750 to 2000.
	(i)	Describe the trend of the average surface temperature as shown in Fig.2. [3]
		Generally increase trend from about 8°C in the 1750s to 9.5°C in the 2000s. Higher (exponential) rate of temp increase since the 1950s. Dip in temperature coincides with the named volcanic eruption such as Mt Pinatubo. (must give named example)
	(ii)	Discuss the impacts of volcanic eruptions and other human activities on global climate. [6]

	<ul style="list-style-type: none"> • Define climate change: variation of global climate or climatic pattern in the long term. • Large volume of CO₂ and water vapour, sulfur dioxide dust and ash are released into the atmosphere during an volcanic eruption such as Krakatou in 1800s. • Sulfur dioxide reacts with water vapor to form sulfur based particles in the atmosphere. • Together with ash and dust, these particles reflect solar energy back into space resulting in global dimming and lower temperature. <p>Other human causes : Deforestation/ urbanization/ Agriculture</p> <ul style="list-style-type: none"> • Deforestation: removal of trees and forest in forested areas. • Removes trees which could have absorb billions of tonnes of CO₂ from the earth atmosphere via photosynthesis. • Deforestation exposes soil to sunlight, increasing rate of oxidation in soil releasing more CO₂ into the atmosphere. <p>With CO₂ in the atmosphere, more heat is trapped leading to higher temperature.</p>
(b)	<p>Figure 3 shows the pathway and seasons of tropical storms. Account for the occurrence of tropical storms in the areas shown in Fig.3. [4]</p>
	<ul style="list-style-type: none"> • Latitude of 9 and 15 degree North and South of the equator. • Where Coriolis Effect is strongest away from the equator. • High ocean surface temp of 26.5°C is necessary bec the heat and moisture. Late summer or early Autumn, when sea temperatures are at their highest • Tropical cyclones usually weaken when they make landfall (i.e. hit the land) because they are no longer being fed by the energy from the warm ocean waters. • In the northern hemisphere they track (i.e. move) anticlockwise ie westwards and clockwise ie eastwards due to the Coriolis effect.
(c)	<p>Using named examples, discuss two possible impacts of tropical storms. [4]</p>

	<p>Physical impact</p> <ul style="list-style-type: none"> • Coastal flooding: bring disruption to basic services such as electricity and water supplies • Destruction of infrastructure such as roads and bridges, which makes transportation of aid supplies difficult in the aftermath of a tropical storm. <p>Economic Impact</p> <ul style="list-style-type: none"> • Cost of repairs to damaged properties such as buildings. Cost of repairs could have been channeled for other infrastructural developmental projects. • Economic cost of damaged crops which could lead higher food prices and food shortage. <p>Social Impact</p> <ul style="list-style-type: none"> • Flood could lead to spread of diseases • Displacement of people from homes, where many have to seek temporary shelter. Affects the poor who might assistance in order to start their lives afresh in the aftermath.
(d)	<p>"Floodplain management is the most effective in mitigating the impact of tropical storms." To what extent do you agree? Explain your answer with reference to studies you have made. [8]</p>

Flood plain management/ Land use control

- Masterplan to reduce potential of flood damage.
- Involves mapping the land use of an area and implementing strategies to prevent floods.
- Ensure that new devt in floodplains are not prone to floods.
- e.g floodplain mgmt. for Cairns in Aust ensures that new devt are not vulnerable to floods.
- In Bangladesh, 50% of the population lives in floodplains and relies on agriculture for their livelihood.
- Mississippi Floodplain management plan allows residents to purchase flood insurance, giving residents a source of funds to rebuild their lives in the aftermath of a tropical storm.
- BUT flood insurance premium could be high and not affordable to segments of the population limiting its effectiveness.
- Limiting devt in flood prone area could only work if authorities exert strict enforcement which required time and manpower.
- People with vested interest in coastal areas could be reluctant to relocate which could result in costly compensation fees from the govt.

Other Strategies

Emergency action

- Involves taking immediate action in response to any situation that poses risks to people health and lives.
- Involves setting up of emergency shelters
- Setting up of community shelter in LDCs such as Bangladesh has helped to reduce the number of deaths in the aftermath of a tropical storms.
- BUT cyclone shelters are very expensive to build and require regular maintenance, especially when they are vulnerable to damage caused by severe tropical storms. LDCs might lack the financial resources to build and maintain them. There is still shortage of cyclone shelters in Bangladesh.
- 2010 typhoon Megi victims were aided by Red Cross with basic necessities such as food, shelter and health care.
- BUT poor coordination could hampered the effectiveness of the aid provided.
- Poor accessibility could delay the delivery of emergency supplies, especially in the event where transport links were damaged during the tropical storm.

Reducing vulnerability of infrastructure

- Designing buildings that are resistant to wind and water damages, regular inspection of river embankments and coastal dikes.
- Buildings can be designed to resistant to wind and water with galvanized hurricane ties nailed to the roof. A layer of secondary water resistance is added to the roof of houses to prevent leaking.
- In USA govt helps homeowners by employing specialized companies to improve the design of the roof and openings of the houses.
- Utility lines such as power and telecommunication and water supply could be placed underground to avoid damage by strong winds and storm surges.
- High financial burden on the govt, might not be affordable to govt in LDCs.

Prediction and warning

- Analysing long-term climatic records in order to predict possible climatic events
- However this method only indicates frequencies of cyclones and not predict the next climatic event.
- Another method is computer modelling which accounts for predictions to be made on the cyclones path as well as areas that will be effected.
- However, it might not be totally accurate as weather conditions may change quickly.

Level	Descriptors
L1 0-3	Brief description of either ONE Emergency response or mitigation response. No examples given
L2 4-6	General discussion of ONE Emergency response and mitigation response. Makes an attempt to link description to less developed countries and mention why they are a it is the best response for LDCs. Some examples given
L3 7-8	Detailed discussion of ONE Emergency response and mitigation response. Makes an attempt to link description to less developed countries and mention why they are a it is the best response for LDCs. Clear links made to less developed countries Relevant examples given (Need to provide a balanced viewpoint with suitable examples. They should also include a concluding analysis)

Section B [25marks]

3	a	Describe the pattern of undernourished population shown in Fig.4 [5]
		<ul style="list-style-type: none"> • Countries with less than 15% undernourished population are found in northern Africa such as Algeria and Egypt. • Countries with an undernourished population of 25%-35% are mainly found in many parts of Sub-Saharan Africa. • Examples of countries are Ethiopia, Chad and Angola found in Central and Eastern Africa. • Those with an undernourished population of 15% to 24% tend to be concentrated in Western Africa bordering the Atlantic Ocean, such as Nigeria and Ghana as well as Namibia in Southern Africa. • South Africa also experiences less than 15% of undernourishment. • Madagascar also experiences more than 35% of its population facing undernourishment. <p>1 mark for identifying regions and another 1 mark for giving at least 2 examples of such regions.</p>
	b i	Describe the distribution of countries with land transaction with Tanzania and the various ways they use the land.
		<p><u>Description of countries with land transaction with Tanzania</u></p> <ul style="list-style-type: none"> • The land transactions are mainly between developed countries and Tanzania. • Most of the transactions are between the countries in Europe • The transactions are mainly for agrofuel crops (about 500,000 ha of land) • The least usage is for forestry (about 30,000 ha of land) • Singapore rents/ buys labour 50,000 ha of land from Tanzania only for food crops <p>(4@1m each. Reserve 1m for the use of data to support answers.)</p>
	b ii	Explain both the positive and negative impacts of selling or leasing land to another country for the purposes shown in Fig 3A.

- (b) Study Fig. 7, which shows the food consumption patterns of USA and Bangladesh.

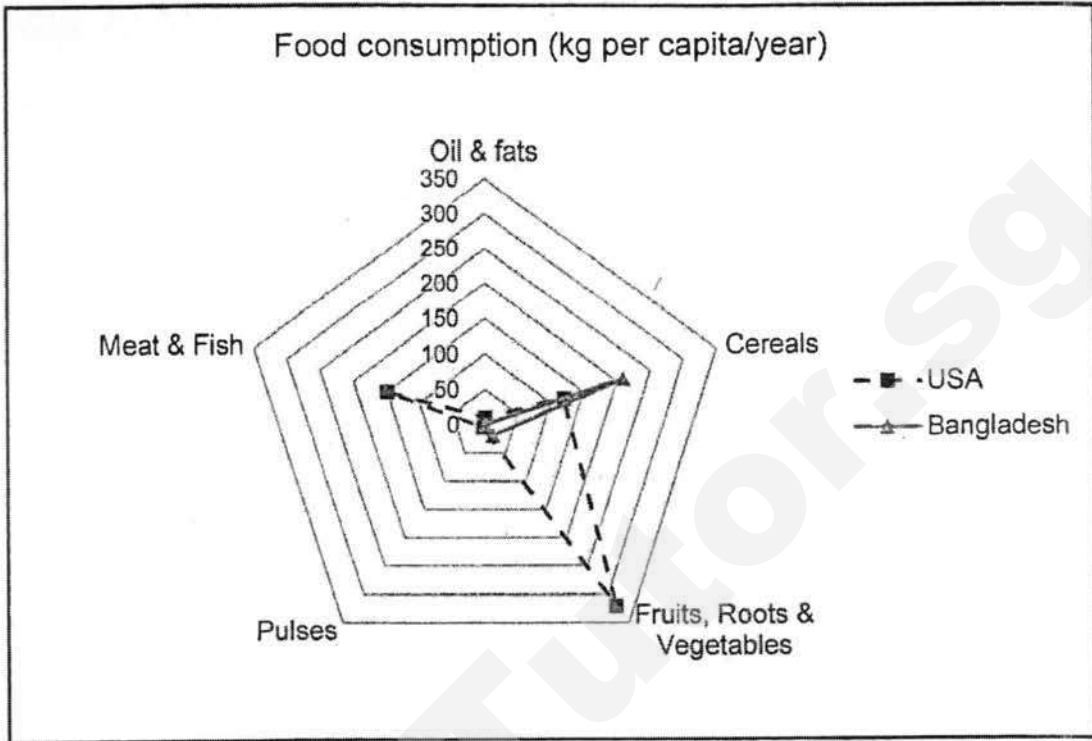

Fig.7

With reference to Fig.7, compare the food consumption patterns in USA and Bangladesh.

[4]

- (c) With the use of examples, explain how migration and population growth can influence the change in food consumption patterns in a country.
- (d) "National efforts made by countries to manage the outbreak of HIV/AIDS has been unsuccessful". How far do you agree with the statement? Support your answer with a named example.

[5]

[8]

[Total: 25]

End of Paper

	<p>Positive impacts</p> <ul style="list-style-type: none"> Increasing the amount of food available in the country that buys/ leases the land. This is so as food can be now grown in Tanzania, processed if needed and sent directly to the country (eg: Singapore). This helps Singapore to increase its food stability by ensuring that there will always be food crops grown and sent to Singapore from Tanzania This also helps in diversifying food source for the country that rents/ buys land from Tanzania. For example, Singapore would not need to rely solely on one country like Malaysia for its food imports as they can now choose to also grow the food in Tanzania. Thus this reduces reliance on just one importer Leasing out land generate income for the government that can be used to help local Tanzanian farmers improve their farming methods <p>Negative</p> <ul style="list-style-type: none"> However, the leasing and buying of land from Tanzania will reduce the amount of land available for agricultural activities for the locals themselves. This might in turn lead to lower food stability and food supply for themselves. However, if Tanzania is not able to grow enough food for themselves, they will have to turn to imports. This will expose them to more market fluctuations in food prices. With lesser land available for food production, and greater fluctuations in food prices, the food prices may increase for the people in the country The competition of land from the foreign country may cause land prices within the country to increase thus making it difficult for local farmers to rear <p>(4@1m each. Reserve at least 1m each for positive and negative impacts.)</p>
c	<p>With reference to Singapore, describe and explain what the government can do to ensure food safety and stability in a country. [4]</p> <ul style="list-style-type: none"> The government plays an active role in ensuring food safety standards are in place and are met. [1] In 2011, there was an earthquake in Japan and subsequent nuclear radiation contaminated farmland and water resources so the government restricted seafood imports from Japan to Singapore for many months so as to ensure the safety of food consumers in Singapore. [1] The Ministry of Development set up a \$5 million fund to help food production businesses grow or import from more places so Singapore will not be dependent on limited sources to feed its people. [1] The fund will also help develop research into how to increase productivity at the 266 farms in Singapore so that we will always have a steady food supply. [1]
d	<p>With reference to examples, evaluate the effects that intensification of food production can have on water and soil quality. [8]</p>

Candidates may include the following material:

- Irrigation allows greater areas of land to be farmed
- Irrigated land likely to have greater yields than when not irrigated
- Regular supply of water – farming can take place throughout the year
- Increase yield leads to increased income for the farmers
- Increased income leads to improvement of standard of living
- Poorer farmers might not have enough knowledge and money to use irrigation leading to inappropriate usage leads to salinisation
- Build-up of salts and soil deterioration decreases future yield of crops
- Flood irrigation → water covers field surface
- Water contains natural salts, left behind by continuous flooding + Dissolution of natural salt rocks, carried to surface
- water used by plants/ evaporated → salts in water left behind
- Soil deterioration leads to lower yields and land becoming infertile
- Decline in income for the farmers = lower standard of living
- Eg: Water in Aswan dams used for irrigation – Sediments and minerals dissolve in water from upper course of river accumulate behind dam – water used to irrigate fields → ↑ salinity
- Waterlogging might also result **too much water is used in fields** – cause soil to become saturated with water
- Nutrients and air cannot enter soil and reach root causing crops to wither & die → ↓ food production, decreases future yield of crops
- Eg: India – **used large amt of water to wash excess salt to reduce salinisation** → waterlogging
- Increased risk of water-borne pests or diseases in irrigated areas, eg: mosquitoes
- High yield seeds increases output per one growth cycle, Shorter growing period, making multiple cropping possible – increases income as farmers can now sell more crops, thus increasing the standard of living with the income
- BUT HYVs need huge quantities of fertilisers and pesticides
- Poorer farmers might not have enough knowledge to on fertilisers and pesticides use leading to inappropriate usage leads to eutrophication
- Eutrophication – increase in nutrients in water bodies, caused by widespread overuse of fertilisers containing nitrogen and phosphorous leads to excess minerals unabsorbed by plants – Excessive minerals and nutrients (chemical fertilisers) from fields washed into rivers and lakes OR leached into soil layers and contaminate groundwater
- causes water source to be undrinkable
- Lowers standard of living of farmers
- Moreover, if yields become affected, the poorer farmers will be much greatly affected as they might have taken loans to buy the seeds

Students must give a valid stand and present a balanced argument.

Students should use appropriate examples to support their stand. Examples could be of a town/ country or how the type of coastal protection measure employed not should not be employed because of its outcome.

Section B [25marks]

Students must give a valid stand and present a balanced argument. Students should use appropriate examples to support their stand. Examples could be of a town/ country or how the type of coastal protection measure employed not should not be employed because of it's outcome.

All examples must be accompanied with a clear place-specific example.

A full answer does not need to include all the above points

Candidates at each level will show the following characteristics:

Level 1 (0 – 3 marks)

- One or two suggestions about increase or damage, eg: 'extra water helps crops grow more, 'more water means more food'
- No place reference or very general, eg: 'in America', 'in Africa'
- No mention of extent/ counter argument, just repetition of question, eg: 'but damages the environment', 'and the environment is damaged'

Level 2 (4 – 6 marks)

- Suggests how both irrigation and HYVs may increase food, eg: ' extra water helps crops grow more' and 'HYV enables greater amount of food to be grown', water means new land can be used and HYVs shortens growing period, multiple cropping made possible'
- Place reference given, but with little detail, eg: 'in India', 'in Australia'
- Brief extent/ counter argument, eg: 'but run offs affects river and streams', or 'but might increase salt content of soil'

Level 3 (7 – 8 marks)

- Suggestions have some detail (often linked to location chosen), eg: 80% agricultural output in Pakistan relies on irrigation', or 'land that was once desert in Egypt now grows crops with water from the Aswan Dam'
- Place reference is fairly specific, eg: 'most of this water is diverted from the Indus', 'most farmland in the Muray-Darling Basin is now irrigated'

Detailed/ supported extent/ counter argument clear, eg: 'but soil quality is reduced when salt is left behind after evaporation, 'farmers need knowledge and money for fertilisers that can increase the HVYs' yield.

4	a	<p>Study Fig. 6, which shows the distribution of HIV/AIDS in parts of Africa. Describe the distribution of the areas with more than 10% of HIV/AIDS infection rates. [3]</p>
		<p>10.1% - 20%</p> <ul style="list-style-type: none"> - Central Africa: Cameroon, Central Africa Republic, [1] - East Coast: Somalia, Kenya, Malawi, Mozambique [1] <p>20.1% - 38%</p> <ul style="list-style-type: none"> - Highest level in Southern Africa: Zambia, Zimbabwe, Namibia, South Africa, Lesotho, Swaziland [1] <p>Must include a named country for marks.</p>
	b	<p>Describe the socio-economic impacts of high HIV/AIDS infection rates in the region shown in Fig.6. [5]</p>
		<ul style="list-style-type: none"> - Reduces life expectancy in countries - Increases infant mortality rate - Orphan crisis: increase number of orphans leading to great burden on extended families and countries. Orphans suffer from emotional trauma, stigmatization, malnutrition and illness - Increase health care expenditure: <ul style="list-style-type: none"> o Govt spendings on treating complications from HIV/AIDS and expensive drugs o Less funds for education system o Lower skilled workforce o Less foreign investment - Slower economic growth: <ul style="list-style-type: none"> o High absenteeism, decline in labour and loss of skilled labour resulting in lower labour productivity o Increase costs of recruitment and training <p>One mark each, must include explanation</p>
	c	<p>With reference to Fig.7 compare the food consumption patterns in USA and Bangladesh. [4]</p>
		<ul style="list-style-type: none"> • People in USA consume more fruits, roots and vegetables (320kg per capita/year) compared to people in Bangladesh where the consumption is only 20kg per capita/year • People in Bangladesh consume more cereals than those in USA by 90kg per capita/year • People in USA consume more meat and fish than those in Bangladesh by 100kg per capita/year • Both USA and Bangladesh consume little oil and fats, ranging from 0kg per capita/year to 10kg per capita/year • Both USA and Bangladesh do not consume pulses (0kg per capita/year)
	d	<p>With the use of examples, explain how migration and population growth can influence the change in food consumption patterns in a country. [5]</p>

Max of 3+2 marks per well-explained point. Maximum of 3 marks if no named examples were used.

- Migration can lead to an increase in the variety of food consumed in a country.
- Migrants introduce new foods to places and drive demand for new food. When migrants relocate, they bring with them their local cuisines. This might then influence the cuisine of the local people, thus forming a fusion of local and migrant cuisines.
- For example, Korean food has become more popular in Manila Philippines due to Korean retirees and the growing number of Korean students staying in Philippines for short term English studies.

OR

- Migration can lead to an increase in the quantity or amount of food consumed in a country.
- Migrants earn a higher wage while working abroad and hence have a higher purchasing power/more able to afford more or wider variety of food
- Population growth can lead to an **increase** in the amount of food consumed in a country.
- Growth rates are faster in LDC than DC. **when population grows** so does the demand for food to meet the needs of a rising world population.
- EG China (LDC) **has a faster population growth** than Singapore hence they consume more food overtime than Singapore (DC)

OR

- Population growth can lead to a change in type of food consumed to more staples.
- Pop growth happens more rapidly in LDCs; and this may increase the **burden** on families to provide for more people than they can afford, hence resulting in consumption of more staples which is more affordable than meats

e Assess the efforts made to manage the outbreak of HIV/AIDS in a country you have studied.

Efforts and success may vary from country but the main ones are included below.

Candidates may express these efforts in a variety of relevant ways.

An indication of success is given for some efforts as examples of what is acceptable.

Educating men, women, adolescents and children about the disease and prevention.

e.g. 'national women and girls awareness days' e.g. March 10th every year | countries such as South Africa.

Some efforts at spreading information are not very aggressive and reach only small percentage of population.

Research, counselling and care – but shortage of health care workers limits success.

Efforts of aid organisations and charities including community projects.

Attitude towards sexual activity

- Abstain from sex until marriage
- Be faithful to partner – can be very successful but difficult in the case of migrant workers.
- Correctly and consistently use condoms – can be as successful as reducing risk by 90% but depends upon overcoming traditions/religious difficulties of communicating to rural areas and free access to condoms.
- Provision of clean drug using equipment – success difficult because of illegal nature of drug taking – not all users will come forward or agree to treatment. Also 40% of countries have laws that prevent or limit effective prevention services.
- Substitute therapy

Attitude towards mother to child transmission

- Antiretroviral drugs for HIV positive mothers and children – success rate of 40% - 70% in reducing transmission of AIDS to newborns in Botswana – large percentage lack access to drugs. In addition, the success depends on adequate nutrition as HIV/AIDS sufferers need more calories and protein than those unaffected.
- Alternatives to breast feeding

Attitude towards blood transfusion

- Blood screening and safe procedures – low level of blood screening in most LDCs but screening in India has seen reduction in infected blood since 1986. In many countries such as India, medical treatment is often difficult because of the discrimination against women with HIV/AIDS in the form of ridicule, harassment and physical assault.

In some countries, there is a national action plan but in others the efforts lack coordination, finance, drugs and equipment

In Kenya, there is a National AIDS Strategic Plan 2009/10 to 2012/13.

Level 1 (0 – 3 marks)

At this level answers will lack detail and may be general in nature. A basic answer that has little development.

Level 2 (4 – 6 marks)
At This level answers will contain some appropriate detail. The content will lack balance and some relevant detail.
This means that only successful or not successful points are considered. OR both successes and failures are considered but support is patchy so that the answer is not full.
Assessment may be given but may be limited or general in nature. A country will be named in answer.
Level 3 (7 – 8 marks)
At this level answers will be comprehensive and supported by sound knowledge.
There will be assessments of the extent to which efforts were successful, i.e. considering both successful and not successful points.
Students will make a stand on which method is considered the best or suggest a method to ensure the

**ANGLICAN HIGH SCHOOL
PRELIMINARY EXAMINATION 2017**



S4

CORE GEOGRAPHY

2236/01

Paper 1

4 Aug 2017

Secondary 4

1 hour 40 minutes

Additional Materials: 5 sheets of writing paper and 1 insert (2 pages)

READ THESE INSTRUCTIONS FIRST

Write your index number and name on all the work you hand in.

Write in dark blue or black pen on both sides of the paper.

You may use an HB pencil for any diagrams or graphs.

Do not use staples, paper clips, glue or correction fluid.

Section A

Answer Question 1.

Section B

Answer **one** question.

Write all answers on the writing paper provided.

Candidates are encouraged to support their answers with the use of relevant examples.

Sketch maps and diagrams should be drawn whenever they serve to illustrate an answer.

At the end of the examination, fasten all your work securely together.

Hand in Section A, Section B and the question paper separately.

The number of marks is given in brackets [] at the end of each question or part question.

This document consists 7 printed pages and 1 insert (2 pages).

[TURN OVER

SECTION A

This question is compulsory.

- 1 A group of students from a school in Dorset set out to study the nature of tourism in Lyme Regis, a popular beach resort, along the Dorset coast of England commonly known as the 'Jurassic Coast'. They wanted to learn more about the profiles of tourists who visit this area and their reasons for visiting Lyme Regis. The students interviewed 136 tourists who visit Lyme Regis on a weekend in July during the summer months.

Photograph A



Fig. 1

- (a) Photograph A in Fig. 1 shows the location of the survey point in the foreground, used by the students when conducting their interviews. The survey point is between the visitor carpark and the entrance to the promenade that leads to the beachfront.

Suggest one advantage of the location of the survey point used by the students to carry out the survey. [1]

- (b) In conducting their survey, the students would like to take into consideration the following issues: gender, age and choice of activities. In order to select tourists to interview, the students decided to use a method of stratified sampling.

Evaluate the use of this sampling method in this investigation. [2]

- (c) Some students thought that there may be a link between age of visitors and their choice of activities. They decided to investigate the following hypothesis:

'The type of activities chosen is dependent on the age of visitors.'

Results of the survey are tabulated in Table 1.

What conclusion can be made regarding the hypothesis? Support your answer with evidence from Table 1. [3]

Table 1

Choice of Activities in Lyme Regis	Age				Total
	Under 20	20-40	40-60	Over 60	
Fishing	2	4	10	6	22
Wind surfing	10	12	5	0	27
History and geology bus tours	8	12	12	9	41
Snorkelling	10	11	2	0	23
Admiring Scenery	0	3	8	12	23
Total	30	42	37	27	136

- (d) Suggest one way to improve the reliability of data collected and explain why it might be useful for the students to do so. [2]
- (e) The students also want to determine the economic impact of the large number of tourists in Lyme Regis. Other than the use of a questionnaire, describe and justify another suitable fieldwork method the students might carry out along the promenade in Photograph A. [4]

Students also carried out a fieldwork exercise on a length of coastline in Lyme Regis, UK, which is exposed to the stormy conditions of an open sea. A large part of the coastline is mainly protected with seawalls. The students wanted to find out about the wave frequency that Lyme Regis experiences so that they may learn more about the impacts of the waves on the coastline and the effectiveness of the seawalls in reducing these impacts.

Fig. 2 (Insert) shows a map of part of the Lyme Regis coastline and Photograph B (Insert) shows one of the areas the students visited.

The students photographed a section of the seawall, which has been further supported by large rocks and boulders known as rock armour. This is shown in Photograph C (Insert).

- (f) Draw and annotate a sketch of the coastal defence strategy shown in Photograph C to show how the strategy is able to protect the coastline. [3]
- (g) Describe and explain the steps the students can take to measure wave frequency at a location in Photograph B safely. [4]
- (h) The students collected data on wave frequency at the location shown in Photograph C. They collected the data on three days in one week. On each day, the students decided to collect three sets of data for greater accuracy. Table 2 shows the number of waves per minute at each time of count on the three different days.

Table 2

Time of count	Day 1	Day 2	Day 3
10.00 am (high tide)	33	35	34
1.00 pm (low tide)	11	12	13
4.00 pm (low tide)	12	13	13
Average number of waves:	15	20	20

- (i) Comment on the time interval chosen for the collection of data on wave frequency shown in Table 2. [1]
- (j) Explain one factor that could affect the reliability of the conclusions made from the data collected shown in Table 2. [2]
- (k) Describe one method the students could use to present the information in Table 2 to show a comparison of wave frequency on the different days. [3]

5

Section B

Answer **one** question from this section

- 2 (a) Study Fig. 3 (Insert) which is an aerial photograph of the Durdle Door Peninsula and its adjacent coast in England.

Account for the uneven coastline along the Durdle Door Peninsula and its adjacent coastline. [4]

- (b) Study Fig. 4 (Insert) which shows a close-up view of Durdle Door and Durdle Cove.

(i) Identify features A and B. [1]

(ii) Describe the different coastal processes that resulted in the formation of features A and B. [6]

- (c) Explain how geology and coastal ecosystems can affect the rate of erosion along coastal areas. [6]

- (d) 'The only way to manage the negative impacts on coastal areas is through the use of laws and regulations.'

How far do you agree? Support your answer with examples. [8]

- 3 (a) Explain how climate change and human activities threaten coral reef ecosystems. [6]

- (b) With reference to Fig. 5, compare and explain the variations in the number of international inbound tourists in Egypt and Thailand between 2000 and 2013. [6]

Number of international inbound tourists in selected countries, 2000-2013

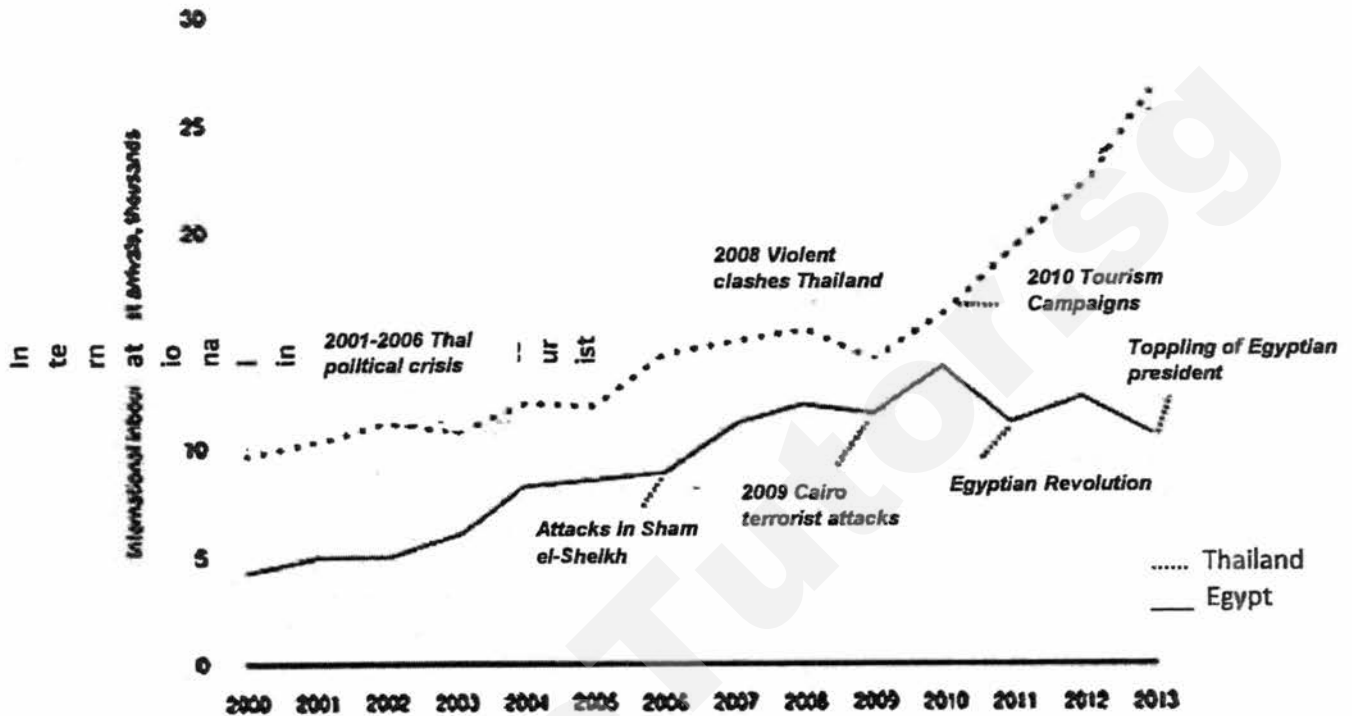

*Inbound tourists: visitors visiting a place outside his usual environment for leisure or business.

Fig 5

- (c) Study Fig. 6 which shows an article on how tourism's changing profile has led to the rapid rise in international tourist arrivals today and in the future.

Tourism's changing profile

International tourist arrivals generally surpassed 1 billion in 2012 and are forecast to reach 1.8 billion by 2030. Today, emerging nations like China spend eight times more on tourism than it did 12 years ago. Chinese tourists spent US\$102 billion in 2012, a 37% increase over the previous year and more than any other country.

The profile of today's travellers differs sharply from that of their predecessors. Demographically, tourists are older— 23% aged 55 or above. Geographically, they tend to live in emerging economies, especially in industrialised cities, rather than in developed countries. Many travellers are better educated and informed with more paid leave. Most holidays are now booked online instead of through travel agencies.

7

Fig. 6

Using information from Fig. 6, explain how the changing profile of travellers contribute to the continual rise in international tourist arrivals. [5]

(d) 'Environmental degradation due to tourism does not justify the benefits that it brings.'

How far do you agree? Support your answer with examples. [8]

END OF PAPER**Acknowledgements:**

Question 1 Photograph A in Fig 1:

https://upload.wikimedia.org/wikipedia/commons/9/9e/Lyme_regis_beach_arp.jpg

Question 1 Photograph B: http://www.discoveringfossils.co.uk/lyme_regis_fossils.htm

Question 1 Photograph C: http://s0.geograph.org.uk/photos/48/40/484056_3c058c07.jpg

Question 1 Fig 2: http://thebritishgeographer.weebly.com/uploads/1/1/8/1/11812015/hard_engineering.pdf

Question 2 Fig 3: <http://www.southampton.ac.uk/~imw/durdle.htm>

Question 2 Fig 4: <http://www.southampton.ac.uk/~imw/durdle.htm>

Question 3 Fig 5: https://www.strategvand.pwc.com/media/image/Exhibit01_Surviving-disaster670x385.jpg

Question 3 Fig 6: http://oecdobserver.org/news/fullstory.php/aid/4255/Tourism_92s_changing_profile.html

**CORE GEOGRAPHY PAPER 1
INSERT 2236/01**

Fig. 2 for Question 1

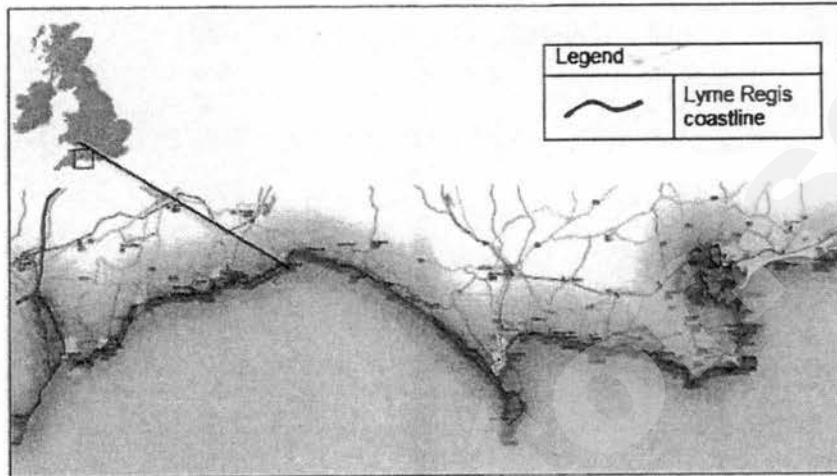

Photograph B for Question 1

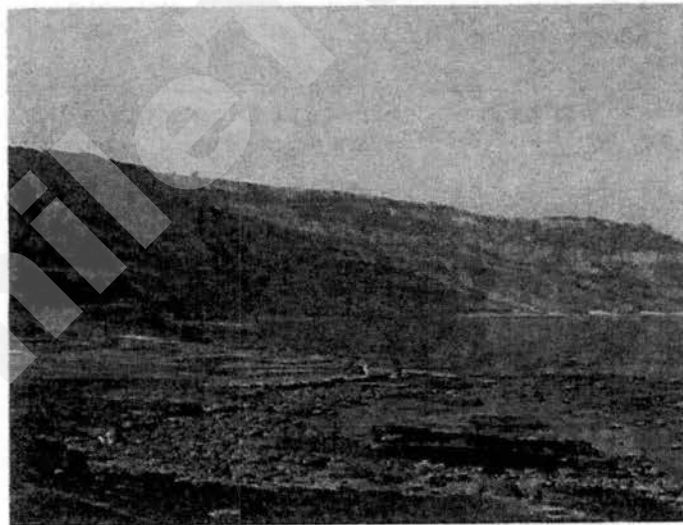

Photograph C for Question 1

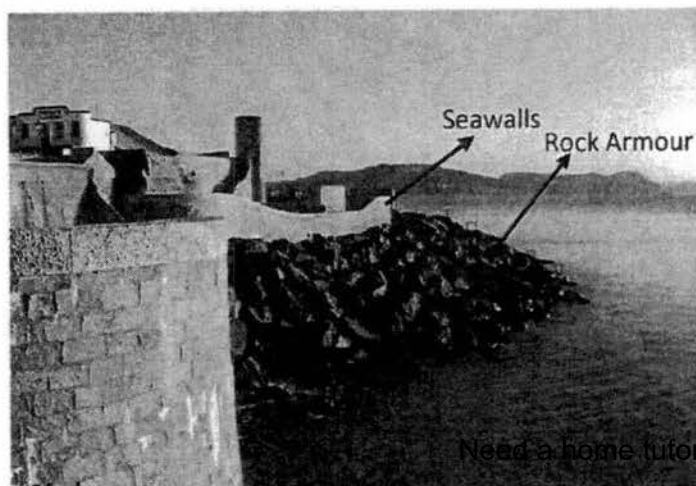
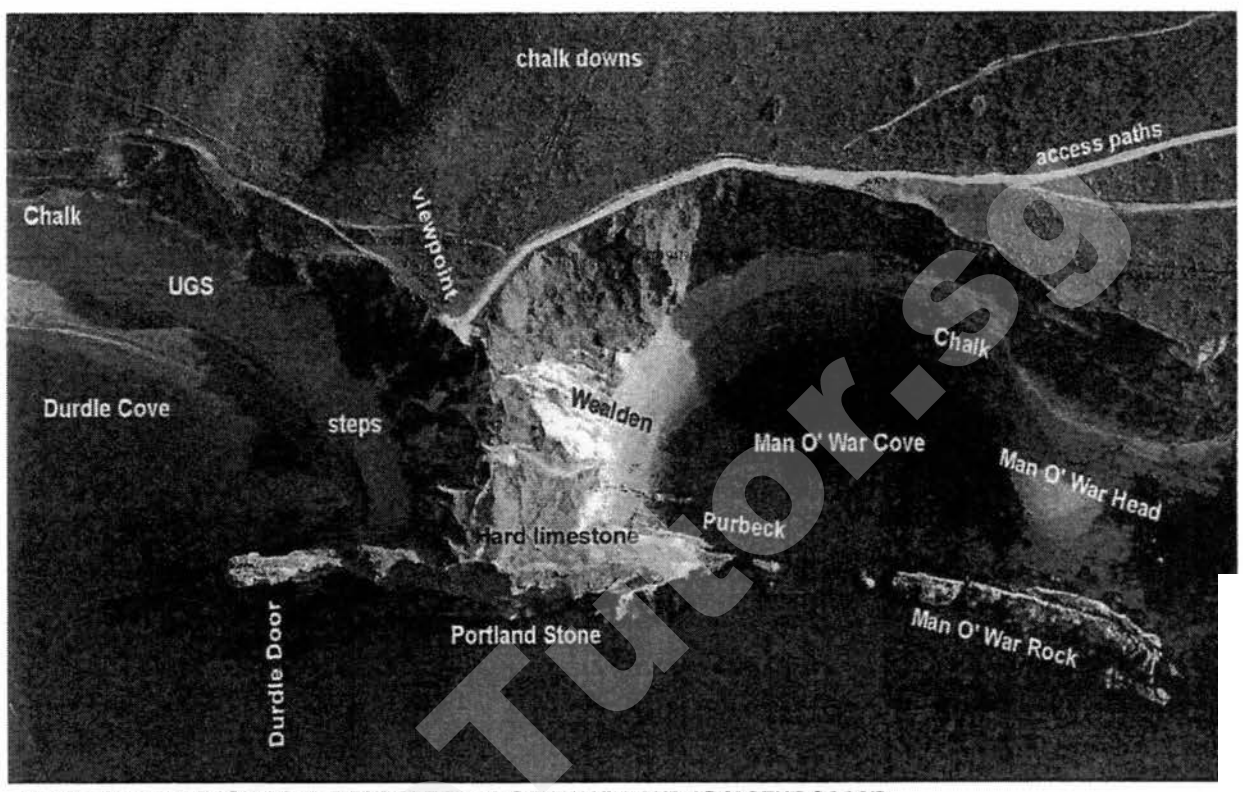
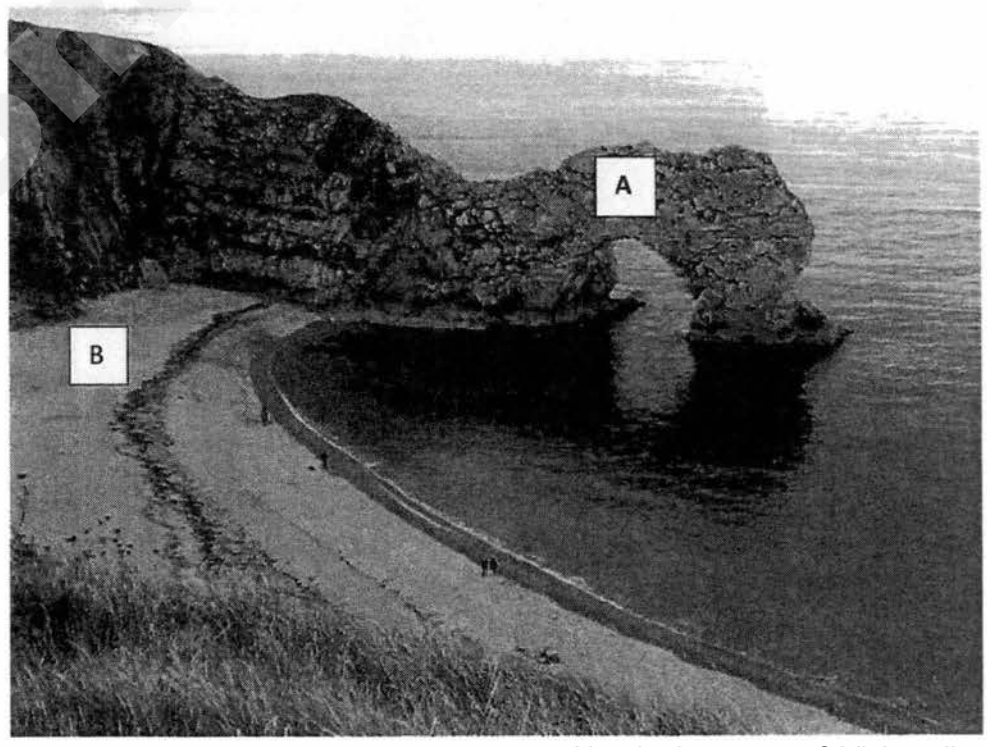

Fig. 3 for Question 2



AERIAL PHOTOGRAPH OF THE DURDL E DOOR PENINSULA AND ADJACENT COAST.
Courtesy of, and copyright of the Channel Coastal Observatory. (Ian West, 2010)

Fi. 4 for Question 2



Name: _____ () Class: _____



**ANGLICAN HIGH SCHOOL
PRELIMINARY EXAMINATION 2017**

S4

CORE GEOGRAPHY

2236/02

Paper 2

20 July

2017

Secondary 4

1 hour 30 minutes

Additional Materials: 5 sheets of writing paper and 1 insert (3 pages)

READ THESE INSTRUCTIONS FIRST

Write your index number and name on all the work you hand in.
Write in dark blue or black pen on both sides of the paper.
You may use an HB pencil for any diagrams or graphs.
Do not use staples, paper clips, glue or correction fluid.

Section A

Answer **one** question.

Section B

Answer **one** question.

Write all answers on the writing paper provided.

Candidates are encouraged to support their answers with the use of relevant examples.
Sketch maps and diagrams should be drawn whenever they serve to illustrate an answer.

At the end of the examination, fasten all your work securely together.

Hand in Section A, Section B and the question paper separately.

The number of marks is given in brackets [] at the end of each question or part question.

This document consists 7 printed pages and 1 insert (3 pages).

2

Section A

Answer one question from this section.

- 1 (a) Fig. 1 (Insert) is an aerial photograph of the Great African Rift Valley in Africa, while Fig. 2 shows its location on a map.

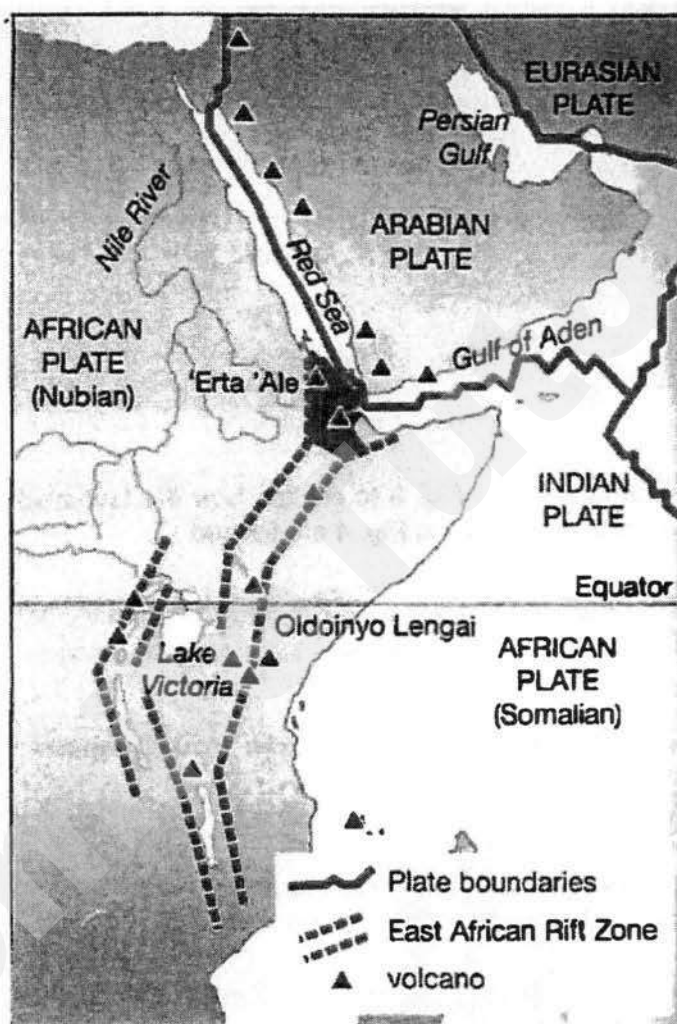

Fig. 2

Use Fig. 2 to explain how the formation and appearance of the rift valley shown in Fig. 1 are a result of plate tectonics. [5]

- (b) Study Fig. 3 (Insert), which shows the magnitude of the earthquake that occurred offshore Japan, and Fig. 4, which shows the wave heights of the tsunami that formed as a result of the earthquake.

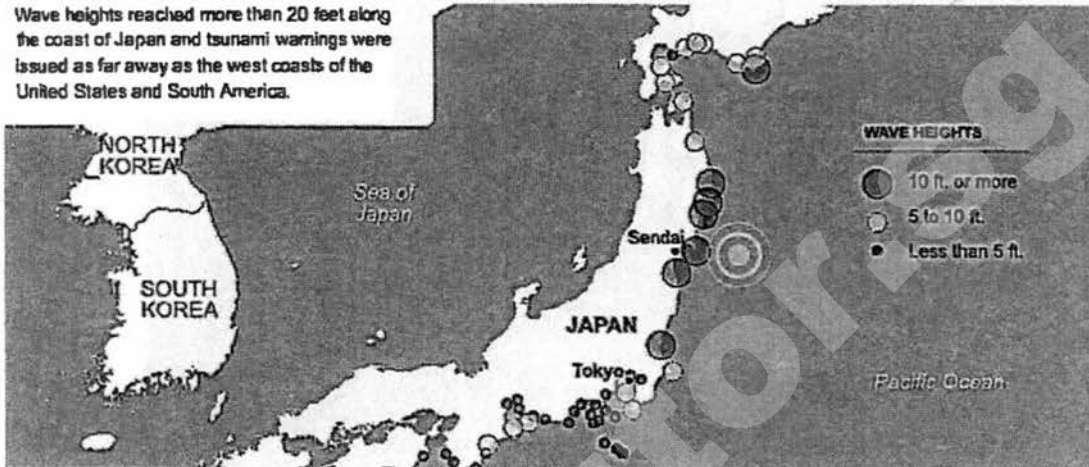

Fig. 4

- (i) Use information from Fig. 3 to explain how the tsunamis with wave height of 10 ft. or more as shown in Fig. 4 are formed. [4]
- (ii) Suggest the possible impacts of the earthquake and tsunami along the Japan coastline. [4]
- (c) Explain how land use regulations can help reduce impacts of earthquakes and tsunamis. [4]
- (d) 'Distance from the epicentre is the most important factor affecting the extent of damage of an earthquake.'
- Do you consider this statement to be true? Explain your answer. [8]

- 2 (a) Fig. 5 shows the locations of earthquakes that have occurred over the years.

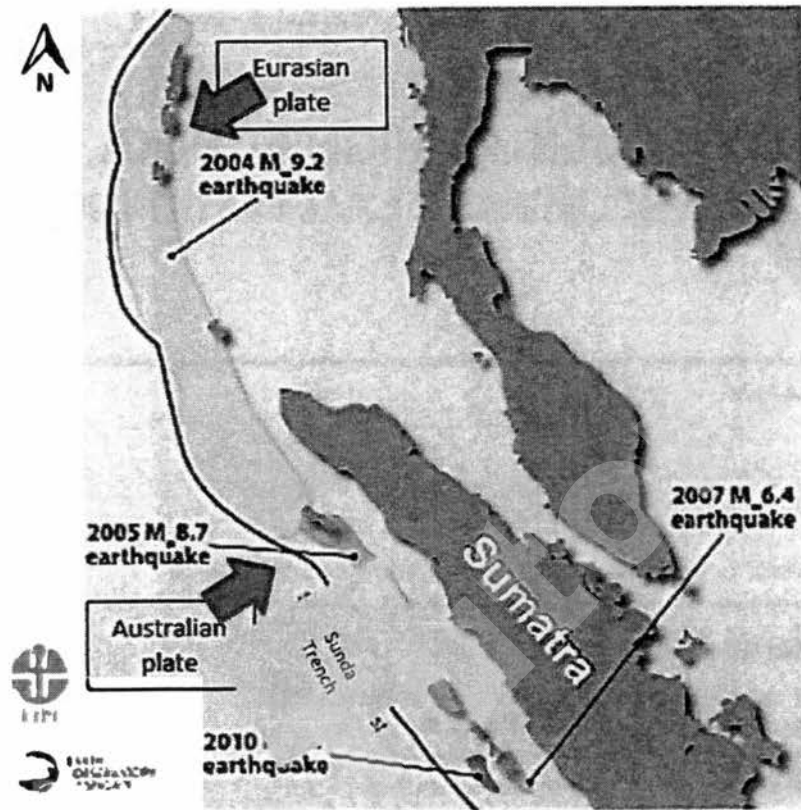

Fig. 5

Describe the pattern of earthquakes along the Sunda trench over the years shown in Fig. 5 and explain why earthquakes occur there. [5]

- (b) Study Fig. 6 (Insert), which shows countries' potential vulnerability to climate change.

Describe the distribution of the countries' potential vulnerability to climate change and the possible impacts to the countries that are very vulnerable to climate change. [6]

- (c) Compare the characteristics of monsoon winds and local winds. [3]

- (d) Fig. 7 (Insert) shows the satellite images of the before and after destruction on urban port city of Tacloban.

Explain how Typhoon Haiyan caused the damages shown in Fig. 7. [3]

- (e) 'Climate change brings about mostly negative impacts.'

To what extent is this true? Support your answer with evidence. [8]

5

Section B

Answer **one** question from this section.

- 3 (a) Fig. 8 (Insert) shows the daily calorie intake per capita in 1961 and 2009.
- (i) Using Fig. 8 (Insert), describe how daily calorie intake per capita has changed across the world over the years. [4]
- (ii) Account for the changes observed in part (i). [5]
- (b) Fig. 9 shows a response to a physical limitation in food production.



Fig. 9

- Explain how the strategy shown and other strategies can increase agricultural productivity despite physical limitations. [4]
- (c) Explain how food shortages can be caused by social factors. [4]
- (d) "The impacts of inadequate food consumption are more serious than excess food consumption."
To what extent do you agree with the statement? Support your answer using evidence. [8]

- 4 (a) Study Fig. 10, which shows the world's food security situation based on the global supply and demand conditions for grains.

Global Supply and Demand conditions for grains 2001 and 2012

	2001 (million tons)			2012 (million tons)		
	Output	Consumption	Net surplus/deficit	Output	Consumption	Net surplus/deficit
World	2,060	2,060	0	3,025	3,025	0
Developed countries	637	530	107	681	608	74
Less developed countries	1,424	1,530	-106	2,344	2,418	-74
• Middle-income countries	484	565	-81	1,133	1,194	-61
• Low-income countries	939	965	-26	1,211	1,223	-12

Fig. 10

Describe how far the food security situation for grains has changed between 2001 and 2012. [5]

- (b) Study Fig. 11, which is a climate map of Odisha, formerly known as Orissa, India and Fig. 12 (Insert), which is a photograph of a village in Odisha.

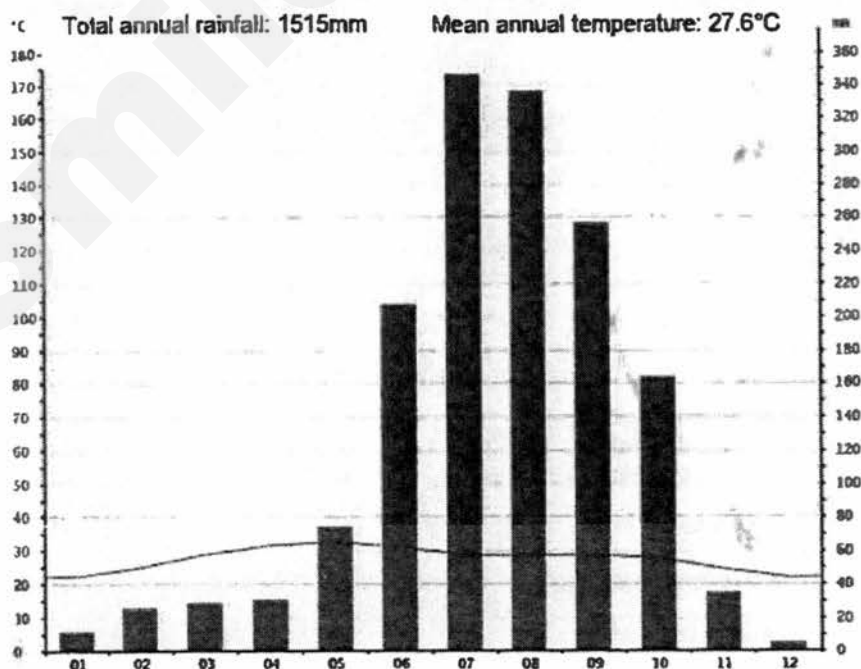

Fig. 11

Use Fig. 11 and Fig. 12 to explain the social and environmental factors that contribute to the spread of malaria in Odisha. [5]

- (c) Study Fig. 13, which is an excerpt of an article about the challenges of malaria prevention in less developed countries.

Effective control and treatment of malaria presents enormous logistical challenges. Malaria is a disease that stems from and causes poverty, and many at-risk populations live in extremely destitute, remote areas. Poor, rural families are the least likely to have access to the preventative measures that are fundamental to malaria control, and may live kilometres from the nearest healthcare facility.

Fig. 13

Use Fig. 13 to suggest the possible challenges to managing the spread of malaria in less developed countries. [3]

- (d) Explain how malaria may limit the economic development of a country. [4]
- (e) 'Communities are more effective than governments in managing the spread of diseases.'

Do you consider this statement to be true? Explain your answer. [8]

END OF PAPER

Acknowledgements

Fig. 1: <https://s-media-cache-ak0.pinimg.com/originals/33/0c/16/330c1686ce8412f78023040f59ac6689.jpg>

Fig. 2: http://year9scienceourchangingearth.weebly.com/uploads/3/1/9/3/31938515/3103378_orig.png

Fig. 3: <http://www.nytimes.com/interactive/2011/03/11/world/asia/maps-of-earthquake-and-tsunami-damage-in-japan.html#panel0>

Fig. 4: <http://www.nytimes.com/interactive/2011/03/11/world/asia/maps-of-earthquake-and-tsunami-damage-in-japan.html#panel0>

Fig. 5: <http://www.earthobservatory.sg/outreach/natural-hazard-outreach/west-sumatra-tectonics-and-tsunami-hazard>

Fig. 6: https://www.washingtonpost.com/news/worldviews/wp/2013/11/15/8-maps-that-explain-why-typhoon-haiyan-hit-the-philippines-so-hard/?utm_term=.d74d12145cde

Fig. 7: <http://www.npr.org/sections/thetwo-way/2013/11/14/244996256/images-of-tacloban-before-and-after-typhoon-haiyan>

Fig. 8: <https://ourworldindata.org/food-per-person/>

© Anglican High School Humanities Department 2017
2236/02/S4 PRELIMINARY EXAMINATION /2017

Fig.9: <https://www.britannica.com/topic/terrace-cultivation>

Fig.10: <https://ourworldindata.org/food-per-person/>

Fig.11: <https://en.climate-data.org/location/2813/#climate-graph>

Fig. 12: <http://www.indiamike.com/india-images/pictures/tribal-village-near-onukdelli-orissa>

Fig. 13: <https://malariajournal.biomedcentral.com/articles/10.1186/1475-2875-8-S1-S2>

SmileTutor.sg

**CORE GEOGRAPHY PAPER 2
INSERT GEOGRAPHY 2236/02**

**Fig. 1 for Question 1
Aerial photograph of the Great African Rift Valley in Africa**



**Fig. 3 for Question 1
Magnitude of the earthquake that occurred offshore of Japan**

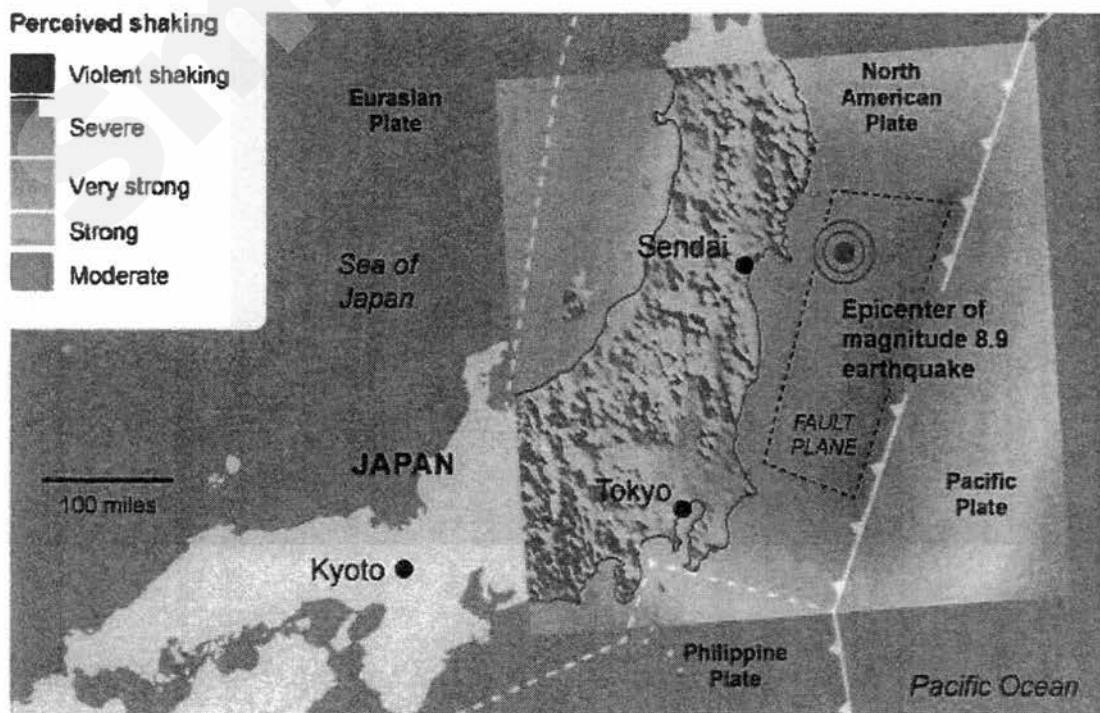

Fig. 6 for Question 2
Countries' potential vulnerability to climate change

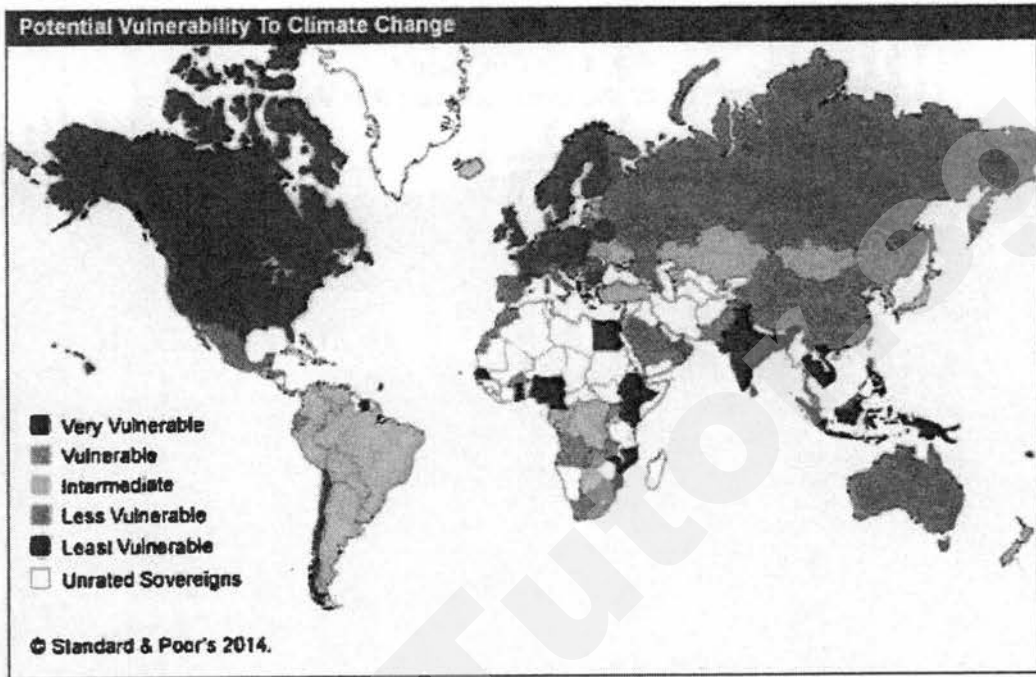

Fig. 7 for Question 2
Satellite images of the before and after destruction on urban port city of Tacloban

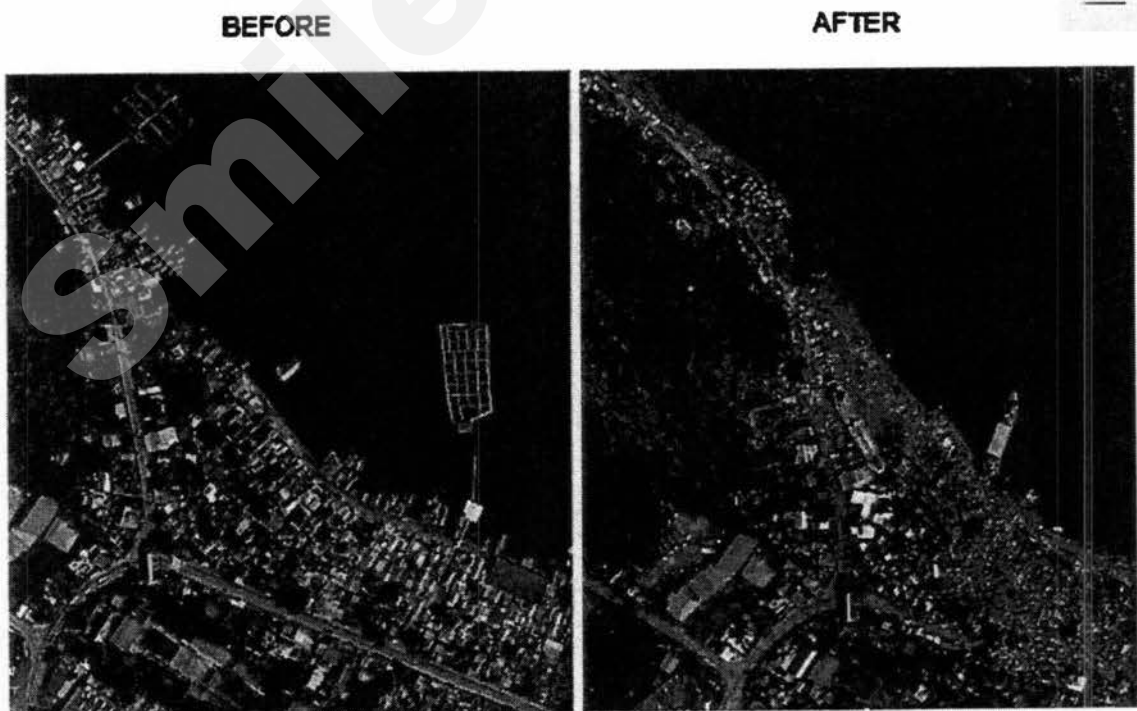

Fig. 8 for Question 3

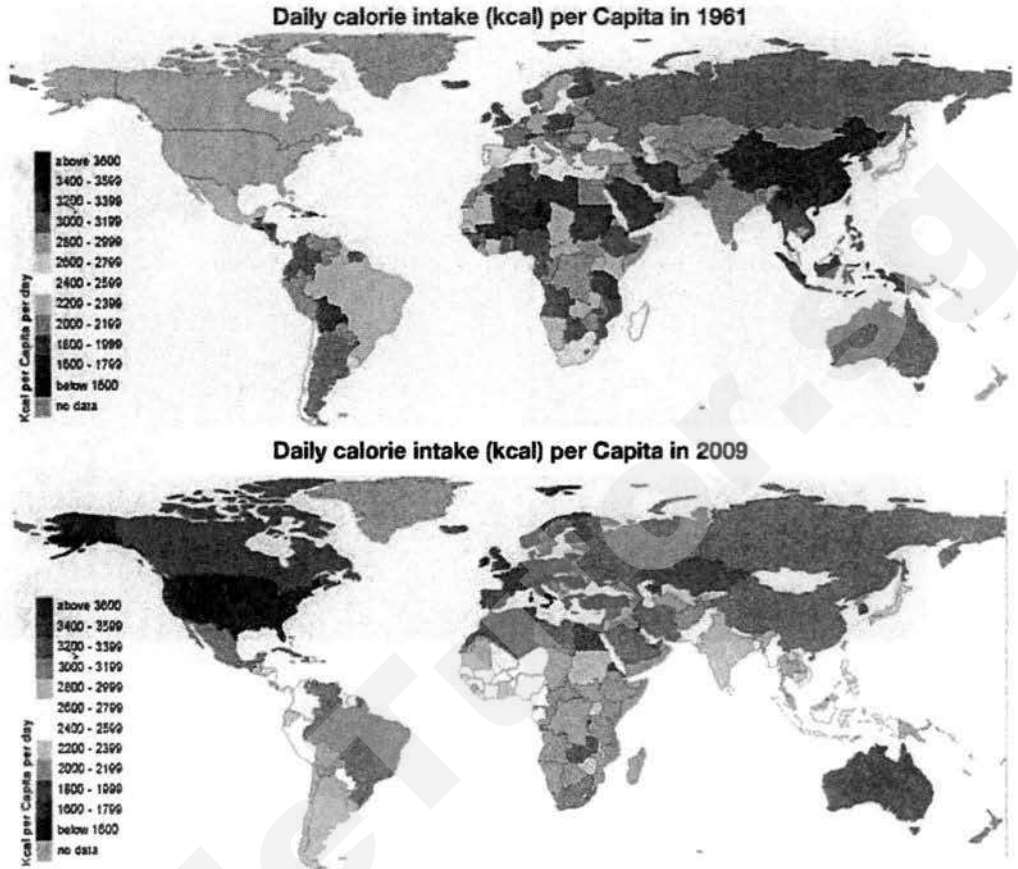

Fig. 12 for Question 4
Photograph of a village in Odisha



SmileTutor.sg

**Preliminary Exam Core Geog Paper 1
Section A**

ANSWERS

- 1 A group of students from a school in Dorset set out to study the nature of tourism in Lyme Regis, a popular beach resort, along the Dorset coast of England commonly known as the 'Jurassic Coast'. They wanted to learn more about the profiles of tourists who visit this area and their reasons for visiting Lyme Regis. The students interviewed 136 tourists who visit Lyme Regis on a weekend in July during the summer months.

Photograph A



*look out for:

physical features of the area eg types of shops, beach ..
activities in the area
width /connectivity of survey area
purpose

- a. Photograph A shows the location of the survey point used by the students when conducting their interviews, which was between the visitor carpark and the entrance to the promenade that leads to the beachfront.

Suggest one advantage of the location of the survey point used by the students to carry out the survey. [1]

Comment: (Give your opinions) Any 2

- Gathering data at the entrance of the promenade is an effective place as it is near carpark where tourists will most likely alight to go to promenade – so can get more people to interview
- Strategic location as most tourists will enter the promenade by as it is near to the entrance to the promenade so there is enough sampling size
- Wide area to conduct the survey and will not cause inconvenience to visitors. [1]

Any other plausible answer

Need a home tutor? Visit smiletutor.sg

- b. In conducting their survey, the students would like to take into consideration the following issues: gender, age and choice of activities.
In order to select tourists to interview, the students decided to use a method of stratified sampling. Evaluate the use of this sampling method in this investigation. [2]

Advantage (1m)

- Stratified sampling is an effective method to ensure sufficient, representative data collection of each group where various sub-groups eg gender, age groups will be represented.
- It gives greater precision in the data collected - due to the representation of each sub group

Disadvantage (1m)

- Some of the criteria for the various subgroups may overlap eg gender and age. This makes analysis more difficult.
- It is not always possible to find people available in the correct age group.

- c. Some students thought that there may be a link between age of visitors and their choice of activities. They decided to investigate the following hypothesis:

'The type of activities chosen is dependent on the age of visitors.'

Results of the survey are tabulated in Table 1.

What conclusion can you make regarding the hypothesis in [c] with reference to the data in Table 1? Justify your answer. [3]

Choice of Activities in Lyme Regis	Age				Total
	Under 20	20-40	40-60	Over 60	
Fishing	2	4	10	6	22
Wind surfing	10	12	5	0	27
History and geology bus tours	8	12	12	9	41
Snorkelling	10	11	2	0	23
Admiring Scenery	0	3	8	12	23
Total	30	42	37	27	136

Table 1

- The hypothesis is true as more strenuous / more physical / sporting activities are more popular with younger groups of people (those under 40).

40 yrs old) but not for the older groups of people (over 40 years age group). (no acknowledgement that hypothesis is true no marks)

Justification / Example:

- Sports like Windsurfing and snorkelling is more popular at 59.7% for those under 40 age group but only 19% and 0% for those between 40-60 years and over 60 years old respectively. [1]
(comparison must be made before 1m is given)

OR

Admiring scenery is most popular with over 60 age group at 44.4% compared to only 7.1% for those 20-40 years old and 0% under 20 years old.

OR

Sporting activities like snorkelling for under 20 years accounts for 66.6% but admiring scenery is most popular for over 60 yrs old at 44.4%.

Reserve 1m for anomaly:

- Anomaly is history and geology tours. This activity is popular across all age groups. It accounts for around 30% for every age group. - no need data for 1m [1]

- d. Suggest one way to improve the reliability of data collected and explain why it might be useful for the students to do so [2]

Suggest - 1m: Repeat the investigation during the December holidays

Explain - 1m: Change in season may affect activities that are preferred.

OR

Suggest – 1m: Increase the number of respondents for those over 60 years and under 20 year age groups. / to ensure equal number of respondents in each age group

Explain – 1m: To get a better representation of their views/ too few interviewed may not be an accurate representation

OR

Suggest – 1m: Repeat the investigation on a weekday

Explain – 1m: The profile of visitors may be different on a weekday and affect the reliability of data collected.

OR

Suggest – 1m: To conduct the investigation along another stretch of beach in Lyme Regis

Explain – 1m: to increase the scope of investigation so that data collected is more representative of the area covered.

Do not accept:

- do it on other days (what day? weekday or another weekend?)

- e. The students also want to determine the economic impact of the large number of tourists in Lyme Regis. Other than the use of a questionnaire, describe and justify
Need a home tutor? Visit smiletutor.sg

another suitable fieldwork method the students might carry out along the promenade in Photograph A. [4]

- Conduct a land use survey method by marking out the main street along the promenade on a blank sheet of paper where the beach front is in Photograph A.
- From the starting point of the promenade, start walking down and observe the different land uses on the ground floor or the second floor of the shops till the end of the promenade.
- Use boxes to represent the shops along the promenade and label the different land uses observed in the respective boxes on the paper

[Compulsory point]

- The greater or lesser the number of tourism related goods and services in the area will suggest whether tourism contributes significantly to creation of jobs and incomes to the residents of Lyme Regis and thus a positive or negative economic impact.

Or

- Use a bipolar perception survey to evaluate economic impact of the area.
- Should include a scale of +2 to -2 with two extreme aspects of 'Many shops and services related to tourism', 'vibrant business environment' to 'few shops and services for tourists' and 'dull business environment'.
- Collate the responses by adding up the scores to determine whether there is a positive or negative economic impact in the Lyme Regis.

[Compulsory]

- The more positive the score will suggest that tourism contributes significantly to creation of jobs and incomes to the residents of Lyme Regis and thus a more positive economic impact.

*May include the use of secondary data (to find out economic impact before and after tourism takes places in the area) for a full answer.

Students also carried out a fieldwork exercise on a length of coastline in Lyme Regis, UK, which is exposed to the stormy conditions of an open sea. The coastline is mainly protected with seawalls and beach replenishment has been done twice to further protect the area and attract tourists.

Fig. 1 (Insert) shows a map of part of the Lyme Regis coastline and Photograph A (Insert) shows one of the areas the students visited.

Fig. 1 for Question 1

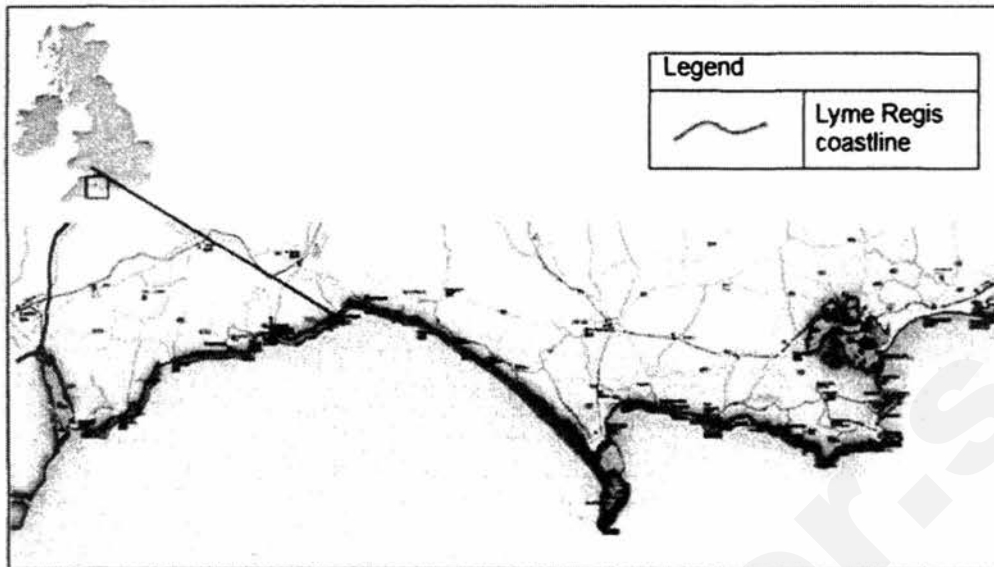

Source: http://thebritishgeographer.weebly.com/uploads/1/1/8/1/11812015/hard_engineering.pdf

Photograph A for Question 1



Source: http://www.discoveringfossils.co.uk/lyme_regis_fossils.htm

f. The students photographed a section of the seawall, which has been further supported by large rocks and boulders. This is shown in Photograph C (Insert).

(i) Draw and annotate a sketch of the coastal defence strategy shown in Photograph C to show how the strategy is able to protect the coastline. [3]

- Reserve 1m for sketch and 2m for annotation explaining how the seawalls and rock armour protects the coastline
- Sketch:
 - o 1m – proportion and orientation, labels to identify seawall and rocks
- Annotation: 2m
 - o 1m – seawalls absorbs wave energy and reduces it / reflect wave energy
 - o 1m – rock armour (gabions not accepted) protect the base of seawalls from erosion / the rocks dissipate energy / the rocks weaken wave energy / reduces wave energy before it reaches seawalls

(ii) Describe and explain the steps the students can take to measure wave frequency at a location in Photograph B safely.

Need a home tutor? Visit smiletutor.sg

- let the tallest student to enter the water but do not go beyond ankle-deep (if explaining method using ranging pole)
- proper footwear to prevent them from slipping
- should choose a spot that is least rocky
- Method: observe and count the number of waves that break in a minute for 5 minutes / 10 minutes
- Method: Calculate the average number of waves per minute to get the wave frequency
- Frequency: Conduct this three times in a day, for 3 days (any number of times is acceptable) to increase reliability
- Recording sheet: Record the results in a recording sheet as shown below: / State column headings if no sketch is given

Timing	1 st reading	2 nd reading	3 rd reading
10am			
1pm			
4pm			

Photograph B for Question 1

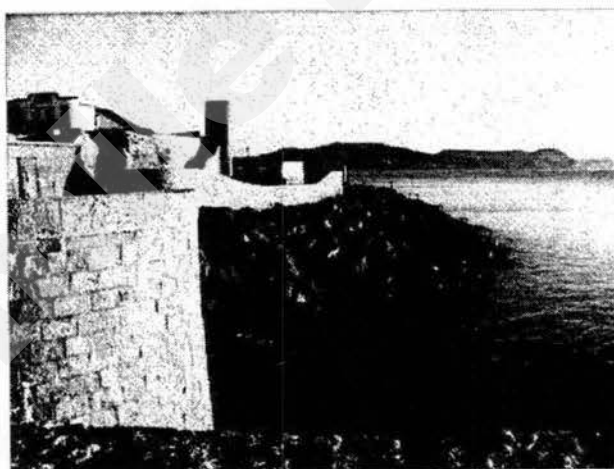

- g. The students collected data on wave frequency at the location shown in Photograph B. They collected the data on three days in one week. On each day, the students decided to collect three sets of data for greater accuracy. Fig. 2 shows the number of waves per minute at each time of count on the three different days.

Time of count	Day 1	Day 2	Day 3
10.00 am (high tide)	33	35	34
1.00 pm (low tide)	11	12	13
4.00 pm (low tide)	12	13	13
Average number of waves:	15	20	20

Need a home tutor? Visit smiletutor.sg

Fig. 2

i Comment on the time interval chosen for the collection of data on wave frequency shown in Fig. 2. [1]

- The students chose a systematic sampling method, where data was collected in equal intervals of 3 hours / every 3 hours. This increases reliability of data.

ii Explain one factor that could affect the reliability of the conclusions made from the data collected shown in Fig. 2. [2]

- 1m - Tide timings – did not take an equal number of counts during both high tide and low tide (once at high tide and twice at low tide)
- 1m - hence data may not be representative of wave frequency at the location for the day / inconsistency may affect the reliability of the data
- only at 1 location hence not representative
- data collected using both high and low tides which may not be accurate as high tides tend to have a higher wave frequencies
- results collected during high and low tide are combined and hence average reading may not be accurate to compare

iii Describe one method the students could use to present the information on Fig. 2 to show a comparison of wave frequency on the different days. [3]

- 1m – method – comparative bar graph
- 1m – variables – x axis is day OR timing, y axis is number of waves per minute
- 1m – comparison/legend – use different colours to represent the different timing or day

Section B

Answer one question from this section

- 1a. Study Fig 1 which is an aerial photograph of the Durdle Door Peninsula and its adjacent coast in England.

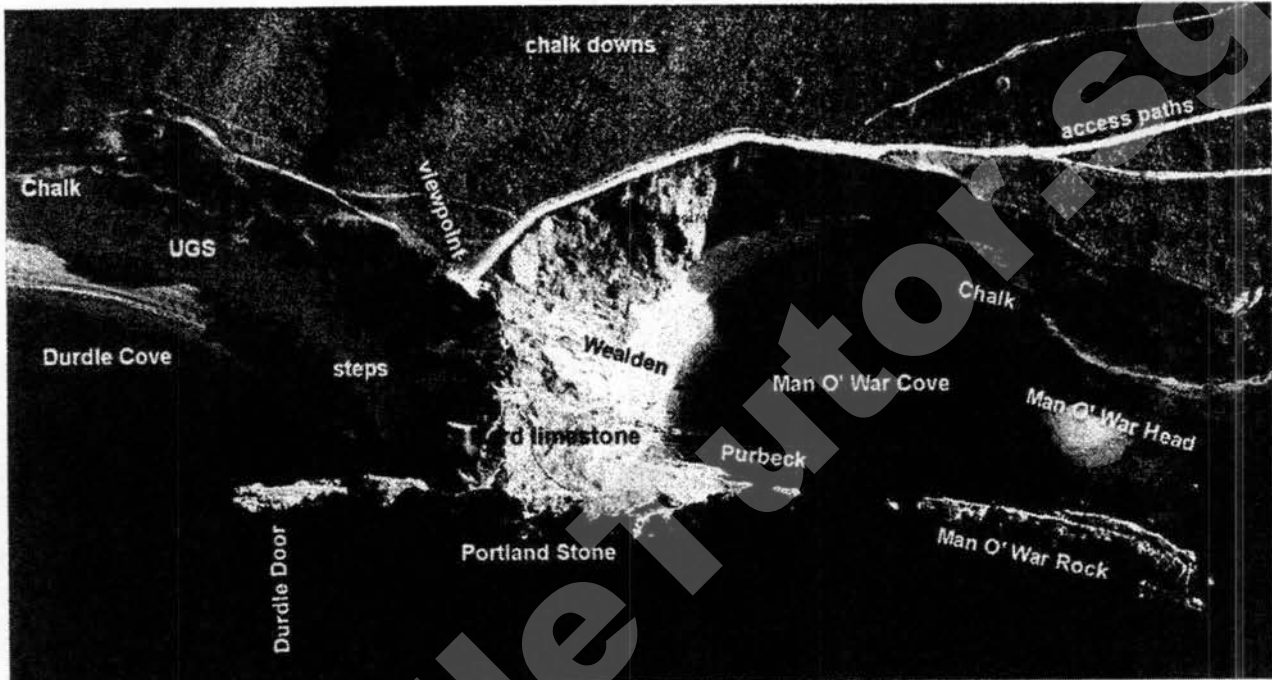

AERIAL PHOTOGRAPH OF THE DURDLÉ DOOR PENINSULA AND ADJACENT COAST.
 Courtesy of, and copyright of the Channel Coastal Observatory. (Ian West, 2010)

<http://www.southampton.ac.uk/~imw/durdle.htm>

Fig 1

Account for the uneven coastline along the Durdle Door Peninsula and its adjacent coastline. [4]

- o The coastline has alternate bands of more resistant rocks like limestone and less resistant rocks like chalk. These rocks are arranged at right angles to the coast / perpendicular to the coastline
- o Less resistant rocks erode faster than harder rocks.
- o As the less resistant rocks (chalk) was eroded away faster, they form bays which are indented / curved in like Man O War Cove
- o while the remaining more resistant rocks (limestone) extend into / protrude out into the sea as headlands (Portland Stone).

(No reference to given figure minus 1m)

- 1b. Study Fig 2 which shows a close up view of Durdle Door and Durdle Cove. [1]

- (i) Identify features A and B. [1]
- (ii) Describe the different coastal processes that resulted in the formation of features A and B. [6]

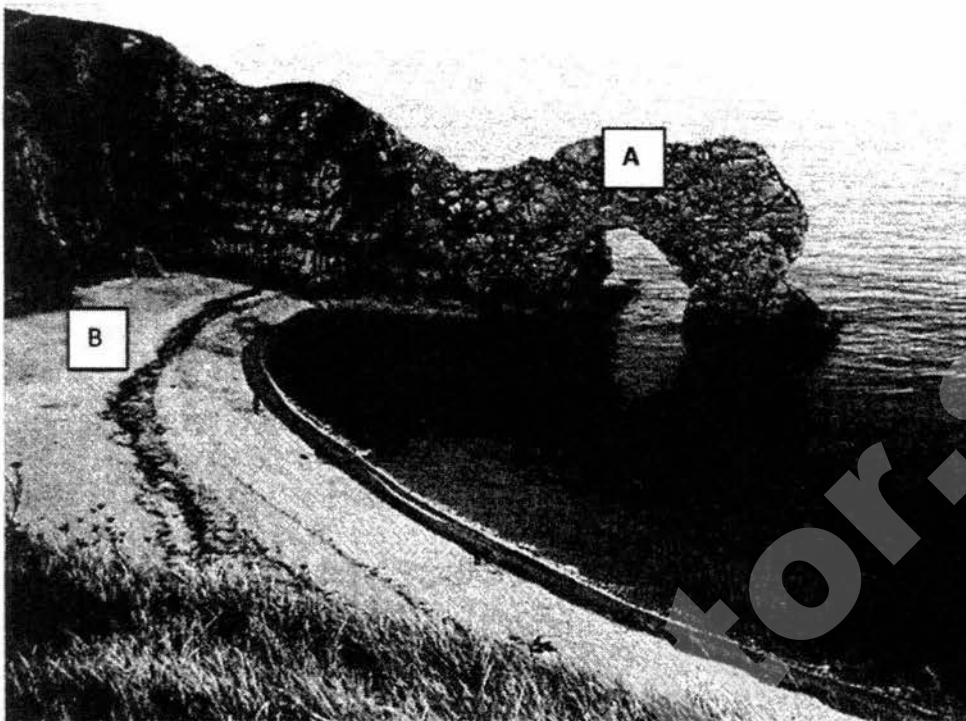

<http://www.southampton.ac.uk/~imw/durdle.htm>

Fig 2

A- Arch
B- Beach

[1]

Arch 3m

- When waves approach the headland, they tend to **refract and curve towards the headlands leading to high energy waves / waves converge at headlands leading to high energy waves or destructive waves**
- **Erosional processes** such as **hydraulic action / abrasion** occur at **lines of weakness** at the base of the headland.
- Eventually this leads to **caves developing on both sides of the headlands** which finally joins leaving a **bridge of rock called an arch.**

Beach 3m

- As waves enter Durdle Cove, they approach feature B and **spread out / diverge as they approach shallower waters** of the bay giving rise to **low energy waves.**
- With low energy waves / constructive waves at B, **swash is stronger than backwash**
- This leads to **deposition of materials** resulting in **beach formation**

1c. Explain how geology and coastal ecosystems can affect the rate of erosion along coastal areas. [6]

- Geology implies the arrangement, structure and composition of rocks found in the area.
- Arrangement – different layers of rocks arranged either in alternate bands perpendicular to the coast etc
- Coasts with harder rocks like granite erode more slowly than softer rocks like chalk or shale.
- Coasts with well jointed rocks / more lines of weaknesses are more vulnerable to erosion / eroded faster when joints of these rocks are attacked by waves
- Ecosystems are communities of plants and animals that interact with each other as well as the environment such as corals and mangroves.
- Coral reefs along coasts provide natural barriers near the coast that slow down the speed and impact of waves on coastline
- Mangroves have aerial and prop roots that help trap sediments – build up of shoreline and thus resist wave erosion
- The prop roots also anchor them firmly to the seabed thus reducing the rate of coastal erosion by reducing the impacts of waves on coast.
- Coral reefs/ Mangroves act as a buffer and absorb wave energy and slow down the waves

1d. 'The only way to manage the negative impacts on the coastal areas is through the use of laws and regulations.'

How far do you agree? Support your answer with examples.

[8]

Marks Descriptors

L1 : 1-3m

- Generalised answers or with minimal detail on at least one strategy in coastal areas.
- A basic answer with little development
- Reasoning rather weak and expression may be unclear. Measures are not thoroughly examined and generalized statements are made about them.
- No or little attempt to address one's stand on the statement.
- No named example is given or only one example is given to show success or limitation. Examples are merely stated, with little or no explanation or evidence

L2 : 4-6m

- Answers contain some appropriate detail. Simple details of at least 1 laws and regulation strategy (limiting damaging activities, protecting coastal areas and restricting development in areas prone to natural hazards) and 1 other strategy (hard or soft engineering)
A clear stand is necessary and evaluation must be done for each measure;
Scripts with only one point should be awarded less than 4 marks.
- Content lack good balance and evaluation and some relevant detail, i.e. simple indication of how strategy/strategies are able to sustainably manage coastal areas
- Support is patchy so argument is not fully substantiated.
- At least 1 named example with some elaboration.
- Good content elaboration and use of examples but weak conclusion– max of 6m
Only two points needed for 4 – 6 marks;

L3 : 7-8m

- Answers are comprehensive and supported by sound knowledge.
- Specific details and elaboration of strategies both laws and regulations and 1 or 2 other strategies.
- At least 2 named example is given (with details provided about the example that helps to illustrate the answer).
- Detailed assessment of relative impact of strategies linking Need with merit. Visit smiletutor.sg
scope/extent/time frame of impacts

3a. Explain how climate change and human activities threaten coral reef ecosystems. [6]

Human activities such as :

- **Fishing and illegal fishing:** like dynamite fishing, can destroy entire colonies of coral reef, the dynamites cause corals to break up and burst. Eg Philippines
- trawlers and anchors from boats scour through ocean floors degrading coral reefs,
- Selective depletion of fish population through spearfishing disrupts delicate balance of the ecosystem's food chain eg parrotfish eating algae and inhibit coral growth.
- **Shipping** – Ships can pollute waters with engine by-products, dump oily ballast into water causing pollution. Oil spills from ships and boats can choke corals due to lack of oxygen and sunlight.
- **Recreation use of coast** – tourism activities eg unplanned expansion of coastal resorts and anchoring of boats result in sewage disposal into water and oil spills from boats. This pollutes water, stress corals and damage them. Eg Japan
- **Dredging and port /coastal development** eg reclamation and expansion of coastal resorts and urban housing - result in waste discharge and heavy sedimentation of the waters cuts off sunlight and promotes algae growth choking the coral polyps (deprived of oxygen, sunlight & food)
- **Fertilizers and sewage disposal** – pollutes water and suffocates corals.

Climate change [Reserve 1m]

- **Rapid increase in sea temperatures** (thermal stress) results in the loss of algae that supports the corals leading to mass coral bleaching. This causes corals to turn completely white or be bleached Eg Seychelles
- **Changes to the frequency and intensity of tropical storms** and cyclones can **destroy reef structure.**
- **Rapid Sea level rises it may causes excessive sedimentation and choke corals.**
- **Increasing acidity in oceans** due to increasing atmospheric carbon dioxide levels reduces the ability of corals to grow well.

(b) With reference to Fig. 3, compare and explain the variations in the number of international inbound tourists in Egypt and Thailand between 2000 and 2013. [6]

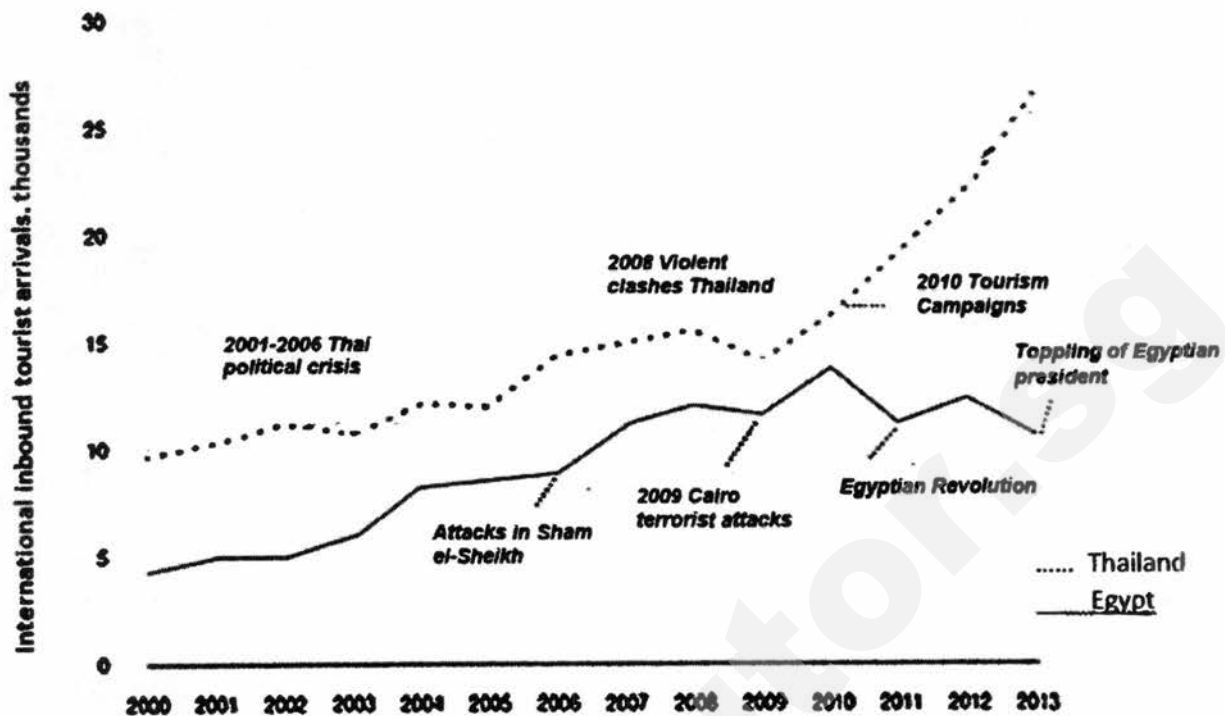

Fig 3

Similarities

- Generally, there is an **increase in inbound tourists to both countries** from 2000 to 2013.
- In Egypt the increase is not very significant of only **5,500** tourist arrivals (4,500 to 10,000) compared to Thailand with an increase of **17,000** (10,000 to 27,000) tourist arrivals.

[2]

OR

- Both **experience** downturns in international inbound tourists whenever they experience political situations in their country.

Example : Thailand : drop of 1,500 inbound tourists in 2008 Thai violent clashes 15K -13.5K and 2009 Cairo terrorist attacks and Egyptian revolution with a drop of 2,500 tourist arrivals.

13.5-11K (Must mention at least 1 example from each country with name, year and decline in numbers)

[2]

Difference

- From 2009- 2013, inbound tourist arrivals for Thailand increased but decreased for Egypt.
- Inbound tourist arrivals for Thailand increased by **85.7%** or **12000** tourists. (26,000-14,000=**12000**) from 2009-2013, but inbound tourists to Egypt declined by **16.7%** or **2,000** tourists. (from 12000-10000= 2000)

Reasons the dips in tourist arrivals

- Tourists do not want to risk getting killed or injured in social unrests. the dangerous situation poses risks.
- The political unrests also disrupt services and cause damage to infrastructure like transport and hotels discouraging tourism.
- Government advisories from many countries against travelling to Egypt or Thailand due to the political situation has also adversely affected tourist arrivals.
- tourists delay or cancel travel plans

Need a home tutor? Visit smiletutor.sg

Reason for the sudden increase in Thailand

- In Thailand there was a significant recovery / increase in tourist arrivals after 2009 due to government measures. Tourism campaigns attracts tourists to go to Thailand by projecting a more positive image of the country and provide incentives to travel agents and travellers eg cheaper hotels and flights etc but not for Egypt

(c) Study Fig 3 which shows an article on how tourism's changing profile has led to the rapid rise in international tourist arrivals today and in the future.

Tourism's changing profile

International tourist arrivals generally surpassed 1 billion in 2012 and are forecast to reach 1.8 billion by 2030. Today, emerging nations like China spends eight times more on tourism than it did 12 years ago. Chinese tourists spent US\$102 billion in 2012, a 37% increase over the previous year and more than any other country.

The profile of today's travellers differs sharply from that of their predecessors. Demographically, tourists are older—23% aged 55 or above. Geographically, they tend to live in emerging economies, especially in industrialised cities, rather than in developed countries. Many travellers are better educated and informed with more paid leave. Most holidays are now booked online instead of through travel agencies

http://oecdobserver.org/news/fullstory.php/aid/4255/Tourism_92s_changing_profile.html

Using information from Fig 3, explain how the changing profile of travellers contribute to the continual rise in international tourist arrivals. [5]

Economic

- **Disposable income** - industrialization and development especially in emerging nations, lead to greater employment and income eg China / India
- Define disposable income – 1m
- Increase in affluence of middle class from emerging economies allows them the purchasing power to go on trips/ holidays. eg China spends eight times more on tourism than it did 12 years ago.

Paid Holidays / leisure

- As a result of stronger economies, unions and changes in society people can expect to receive a minimum four weeks paid holiday. Inevitably if people have more time then there is a greater chance that they will use some of that time in the tourism industry.

Changing Lifestyle

- A fast paced lifestyle and the associated stress of modern living has given some people reason to travel as a form of relaxation
- Moreover, as people become better educated and well-informed, travel has become an avenue for self-discovery. People travel to see places that they learn about from books and the mass media resulting in the growing demand for niche tourism that are thematic, unique and away from the masses.
- The people are more familiar with use of IT / prefer using IT – information is readily available and accessible and up to date. Travel arrangement can be easily made via internet and more bookings are now made online
- Retirees are also major contributors to the growth of tourism especially those above 55 years of age who have the money and time to travel off the beaten track and outback away from cities eg Australia.

- tourists are older because of healthier lifestyles - travel seems to be a productive way to spend the remainder of their healthy years

(d) 'Environmental degradation due to tourism does not justify the benefits that it brings.' How far do you agree? Support your answer with examples. [8]

Level 1 (0-3)

Generalised answers with minimal support if any stand were given at all.

Reasoning rather weak and expression may be unclear.

A basic answer that has little development.

There may be little or no attempt at indicating the positive impacts on LDCs

Level 2 (4-6)

Positive or negative impacts will be supported by appropriate detail.

Or, both positive and negative impacts are considered but support is patchy so that the answer is not full.

Good reasoning and logic in parts of the answer with good expression in places.

There should be at least 1 attempt on a positive impacts

Level 3 (7-8)

Answers are comprehensive and supported by sound knowledge.

Both positive and negative impacts are considered and well supported.

Reasoning is clear and logical with good expression of language.

At least 2 negatives and 2 positives mentioned.

Answers are well supported with detailed examples and evidence.

Name: _____ () Class: _____



**ANGLICAN HIGH SCHOOL
PRELIMINARY EXAMINATION 2017**

S4

CORE GEOGRAPHY

2236/02

Paper 2

20 July

2017

Secondary 4

1 hour 30 minutes

Additional Materials: 5 sheets of writing paper and 1 insert (3 pages)

ANSWERS

Section A

Answer **one** question from this section.

- 1 (a) Fig. 1 (Insert) is an aerial photograph of the Great African Rift Valley in Africa, while Fig. 2 shows its location on a map.

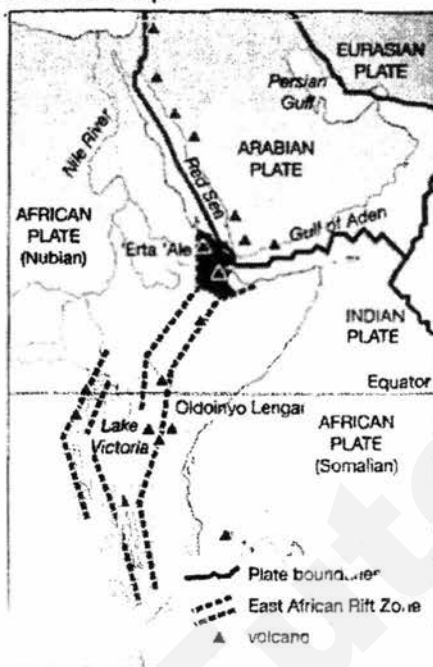

Fig. 2

Use Fig. 2 to **explain how** the **formation and appearance** of the **rift valley** shown in Fig. 1 are a result of plate tectonics. [5]

- The Great African Rift valley formed due to the **divergence between two continental plates**, the **Somalian and Nubian** parts of the African plate – hence the rift valley stretches along the plate boundary
- The plates are pulled apart, **giving rise to faults**. This process is called faulting. A fault is a fracture in the rocks along which the rocks are displaced. **Tensional forces** from these movements result in **parts of the crust being fractured**.
- Along these faults, sections of the crust can extend.
- When sections of the crust extend along fault lines, tensional forces can cause a **central block of land to subside between a pair of parallel faults**, forming a **linear depression**
- surrounded by block mountains which creates its **steep sides**

2 (a) Fig. 5 shows the locations of earthquakes that have occurred over the years.

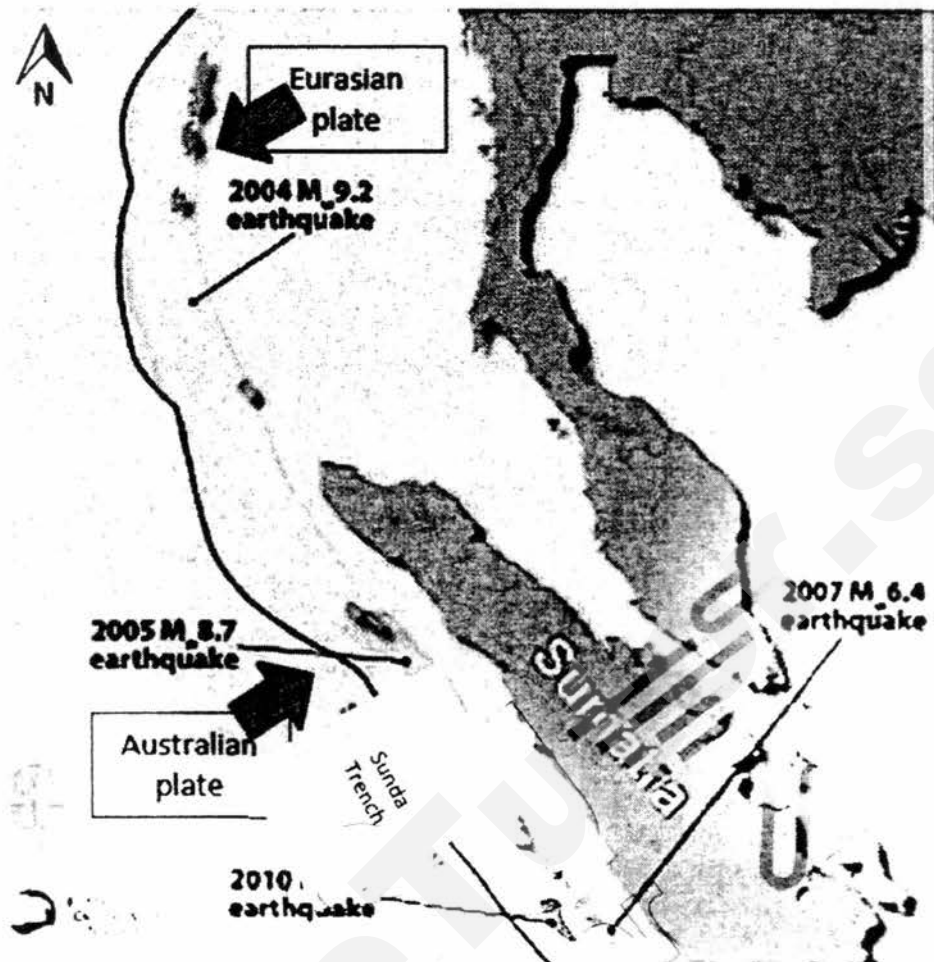

Fig. 5

Describe the pattern of earthquakes along the Sunda trench over the years shown in Fig. 5 and explain why earthquakes occur there. [5]

- **Patterns:**
 - Generally magnitude of earthquakes has decreased over the years towards the south (data)
 - Decreased from magnitude 9.2 in 2004 to 7.7 in 2010.
 - Anomaly: except for 2010
 - Earthquakes occur along the Sunda Trench starting from the Northern part of the trench in 2004, and towards the Southeast over the years.
 - All earthquakes occur eastern side of the Sunda Trench
 - All earthquakes occur close to the plate boundary
- **Why earthquakes occur there:**
 - presence of a convergent plate boundary between the Australian plate and the Eurasian plate
 - the Australian plate subducts under the Eurasian plate creates the immense pressure and friction / compressional force caused by the subduction results in a build up of stress OR
 - the buckling and folding of the Eurasian plate also causes plates to build up friction and stress

- (b) Study Fig. 3 (Insert), which shows the magnitude of the earthquake that occurred offshore Japan, and Fig. 4, which shows the wave heights of the tsunami that formed as a result of the earthquake.

Wave heights reached more than 20 feet along the coast of Japan and tsunami warnings were issued as far away as the west coasts of the United States and South America.

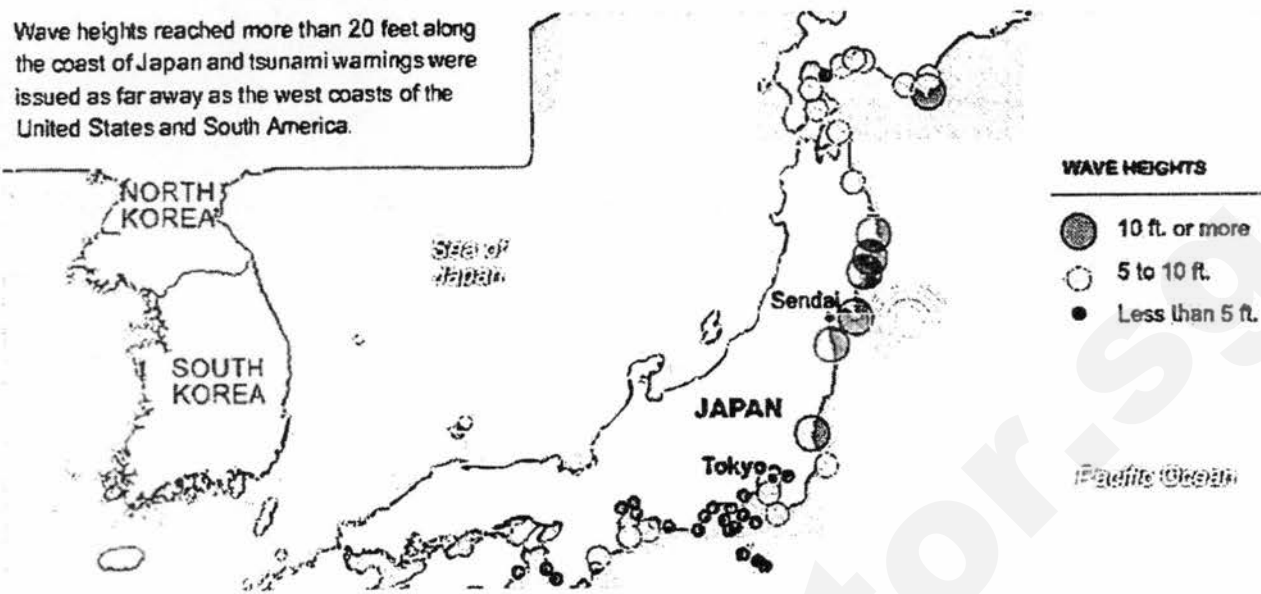

- (i) Use information from Fig. 3 to **explain how the tsunamis with wave height of 10 ft. or more** as shown in Fig. 4 **are formed**. [4]

- The earthquake occurred due to the convergence **of the Pacific Plate and the North American Plate.**
- Formation of the tsunami starts when seismic energy from **an offshore earthquake / undersea earthquake forces out a mass of sea water** in Pacific Ocean
- the **high magnitude of 8.9** means that a large mass of sea water forced out due to high energy **creating high waves of 10 ft.**
- As the **epicentre of the offshore earthquake is close / nearest to Sendai,** it causes **very strong shaking / greater wave energy** that may lead to **bigger waves of higher wave height** hitting Sendai as compared to other areas.
- On **reaching shallower water nearer to the Sendai coastline,** greater **friction** slows the waves and forces them to increase in height.

- (ii) Suggest the possible impacts of the earthquake and tsunami along the Japan coastline. [4]

- Tsunamis can cause a **disruption of services such as the supply of electricity, gas and water in settlements** along the coastline, particularly to dense cities such as Tokyo and Sendai
 - o Vibrations on the ground can **snap pipes and break cables** which **may cause the outbreak of fires**
 - o Communication services such as television broadcasts and telephone connections may also be affected

- Mudflows may occur, where floodwaters from the tsunami may mix with soil debris and flow down slopes, particularly along places affected by the tsunami
- Flooding causes loss of lives
- flooding causes loss of natural vegetation and habitats along the coastline
- Damage to properties: The earthquake can also cause widespread destruction to homes, displacing people – in Sendai where tsunami reaches a height of 10 ft or more, most homes would be flooded by water
 - People will have to reside at temporary shelters, which may lead to other bigger problems such as a spread of diseases or insufficient resources
- Infrastructure such as roads and bridges may also crack due to the force of the earthquake
- Earthquakes and tsunamis can cause loss of great number of lives
 - For places with wave height of 10 ft or more, such as in Sendai, lives may be lost

This question was well done. Many could describe the cause and impacts well.

(c) Explain how land use regulations can help reduce impacts of earthquakes and tsunamis. [4]

- Land use regulations are a set of rules implemented to restrict developments in certain areas including across fault lines or at risk of liquefaction. (Land use regulations can help reduce impacts of earthquakes as it prevents housing and industrial development from occurring at areas close to or across fault lines...)
 - ...where the impacts of earthquakes would be greater due to proximity to the epicentre/faultlines, where energy released is greater, hence less destruction of buildings / loss of lives
 - Elaboration of Liquefaction: liquefaction occurs when vibrations from an earthquake cause saturated soil to flow like liquid. The ground becomes unstable and buildings should not be constructed in these areas as it is unsafe.
 - Elaboration of low-lying: Another land use regulation is the prohibition of constructing new buildings on low-lying land which are vulnerable to tsunamis. Low-lying areas are at risk of flooding by tsunamis.
- Developments may be allowed only when protective barriers such as seawalls facing the ocean are constructed
 - Places along coastlines which are low-lying can be protected if seawalls are built to absorb the impact of large waves such as tsunamis or to prevent flooding caused by tsunamis

- (d) 'Distance from the epicentre is the most important factor affecting the extent of damage of an earthquake.'

Do you consider this statement to be true? Explain your answer. [8]

Level 1

Generic statements of distance from epicentre. Examples are very general. No discussion of one other factor. No relevance to extent of damage or examples that illustrate it.

Level 2

Definitions of terms are given

Explanation of distance of epicentre and one other factor given but very brief

Examples may be brief (name of country only) or no examples given or only 1 example given.

Examples may not be relevant to extent of damage

No evaluation in conclusion.

Level 3

damage and earthquake

Definitions of terms are given

Explanation of distance from epicentre and one other factor

Both factors are well-explained and precise

At least two precise examples

Evaluation made in conclusion

- o when the plates can no longer withhold the stress, the plates may slip several metres causing a release of energy. The release of energy forms earthquakes, which occur on the surface of the plates

(b) Study Fig. 6 (Insert), which shows countries' potential vulnerability to climate change.

Describe the distribution of the countries' potential vulnerability to climate change and the possible impacts to the countries that are very vulnerable to climate change. [6]

Description of distribution:

- Overall spatial distribution - Countries that are very vulnerable to climate change are located nearer to the Equator while countries further away from the Equator are generally less vulnerable.
- LDCs tend to be more vulnerable to climate change than DCs
- The areas that are very vulnerable and vulnerable / more vulnerable - in South Asia, countries such as India are very vulnerable to climate change while in Southeast Asia, most countries except Malaysia are very vulnerable to climate change. Some parts of Africa such as Ethiopia and Kenya are very vulnerable to climate change.
- The areas less vulnerable and least vulnerable to climate change - countries which are less vulnerable include Russia and Australia while places that are least vulnerable include most of North America and Europe

Possible impacts on areas that are very vulnerable:

- Sea level rise
 - a. Cause for Sea level rise: Increase in the mean height of the sea's surface between high and low tide relative to land. This is caused by higher temperatures which cause water to expand/causes glaciers to melt, adding meltwater to the sea.
 - b. Impact of sea level rise: Flooding of low-lying coastal areas such as islands in Southeast Asia, India, Bangladesh
- Frequent extreme weather events
 - a. Extreme weather events: severe and rare weather phenomenon that results in significant economic losses and the loss of lives
 - b. Higher temperatures have resulted in greater amounts of water vapour and latent heat in a warmer atmosphere.
 - c. Eg. Heat waves, floods, droughts and tropical cyclones
- Spread of infectious insect-borne diseases
 - a. Increased rainfall and temperatures is favourable for mosquitoes to breed (allows spread of malaria and dengue fever)
 - b. As temperate countries get warmer, mosquitoes are able to breed further up north of the Equator
 - c. Distribution of occurrence of infectious insect-borne diseases is also changing. E.g. dengue fever was reported in the cool climate areas of Nepal and Bhutan for the first time in 2004.
- Shortening of growing season in certain regions



Fig. 9

Explain how the strategy shown and other strategies can increase agricultural productivity despite physical limitations. [4]

Terracing (name the strategy and say create flat land on steep slope) and 1 other strategy well-explained:

- o Terracing ⑦ creating flat land on steep slopes through cutting steps on slopes ⑦
 - maximises land space for farming to overcome steep relief conditions
 - overcome the problem of erosion on steep slopes and loss of nutrients
- o Greenhouses ⑦ allow people to regulate the temperature and environmental conditions → mitigating unsuitable climatic conditions/ increases the growing season and allows certain types of crops to be grown throughout the year
- o Farming technology:
 - Using chemical fertilisers ⑦ replaces nutrients in soil → allows land to be used continuously/ maximising areas with poor soil
 - Irrigation ⑦ overcome water shortages and hot weather
 - HYVs →
 - increased resistance to pests and diseases → overcome problem of pests OR
 - the ability to grow within a shorter growing season → overcome land constraints
- o Biotechnology - some breeds of GM have high yield for small land area hence overcoming land constraints, some are drought resistant, some are pest-resistant
- o Water and soil conservation ⑦ no-till farming overcome poor soil conditions
- o Crop rotation is a way of growing several crops on the same land areas in a specific order, following the changes in seasons.
 - helps farmer overcome soil erosion and prevent a decrease in soil fertility

- Disadvantage (Cool regions are now getting hotter, less conducive for crop growing)
- Apples and cherries production in Yunnan is reduced as they need cool conditions.
- Wheat yield has decreased in Canada.

(c) Compare the characteristics of monsoon winds and local winds.

[3]

1m for each comparison:

Points of comparison	monsoon	local	Answer
scale	large	small	Monsoon winds occur at a larger scale than local winds
area	Regional	Within a country	Monsoon winds may occur across oceans or regions while local winds can occur over a small area in a country
time	Occurs during specific seasons such as the middle and end/start of the year	Occurs at any time throughout the year	Monsoon winds occur within specific times of the year or seasons such as in the middle and end/start of the year while local winds may occur at any time throughout the year
direction	Crosses oceans	Wind moving from sea to land	Monsoon winds cross oceans such as the Indian ocean during the southwest and northeast monsoon while local winds are winds that move from the sea to land or vice versa

(d) Fig. 7 (Insert) shows the satellite images of the before and after destruction on urban port city of Tacloban.

Explain how Typhoon Haiyan caused the damages shown in Fig. 7.

[3]

- Strong winds could have pushed water to coast causing a storm surge
- Sudden rise of sea level in which water is piled up against a coastline beyond normal conditions at high tide.

- This causes loss of lives and damage to infrastructure and property due to flooding/In the aftermath of Typhoon Haiyan, it can be observed that the settlements and transport routes along the coastline have been destroyed.
- High wind speed could have caused the damage to the infrastructure
- Large amount of rainfall causes flooding inland and also cause rivers to overflow.

(e) 'Climate change brings about mostly negative impacts.'

To what extent is this true? Support your answer with evidence.

[8]

Level 1

Generic statements of negative impacts of climate change. Examples are very general. No discussion of positive impacts of climate change. No link to enhanced greenhouse effect. Missing negative or positive impacts of climate change. Missing one example for one point.

Level 2

Definitions of terms are given
 Explanation of negative impacts of climate change and one other factor – very brief
 Examples may be brief (name of country only) or no examples given.
 No link to enhanced greenhouse effect and global warming
 No evaluation in conclusion.

Level 3

Defined climate change
 Definitions of terms are given
 Explanation of negative impacts of climate change and one other factor
 Both factors are well-explained and precise
 At least two precise examples
 Links to enhanced greenhouse effect and global warming made
 Evaluation made in conclusion

Section B

Answer **one** question from this section.

3 (a) Fig. 8 (Insert) shows the daily calorie intake per capita in 1961 and 2009.

(i) Using Fig. 8 (Insert), describe how daily calorie intake per capita has changed across the world over the years. [4]

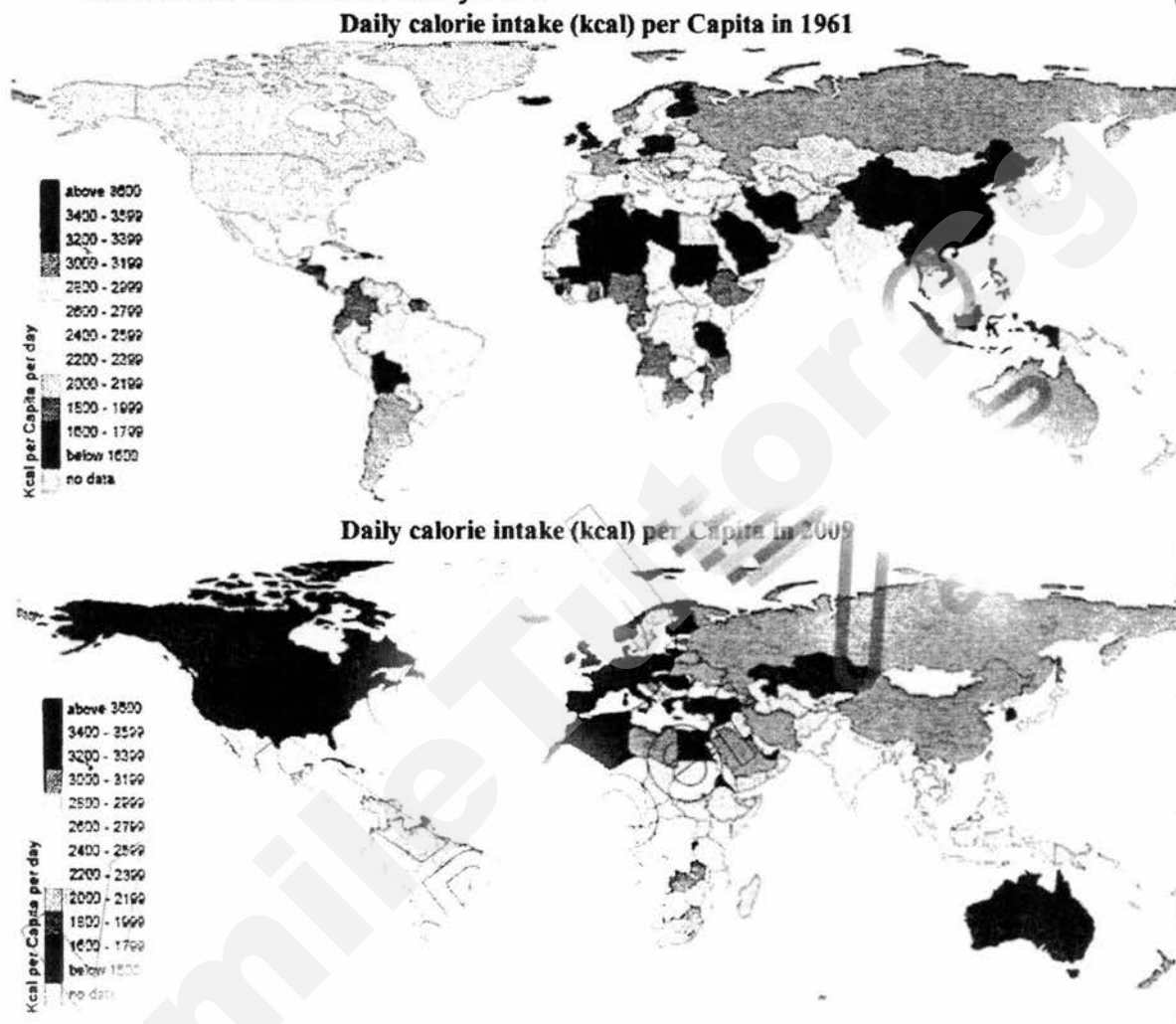

- Generally, daily calorie intake has increased across the world over the years.
- Daily calorie intake remains higher for the DCs than the LDCs
 - DCs such as those in North America like the USA and Canada, in Europe like UK and Norway, the daily calorie intake per capita has been above 2800 kcal over the years
 - Daily calorie intake per capita in LDCs such as those in most parts of Sub-Saharan Africa like Ethiopia and Madagascar has remained below average at between 2000-2399 kcal
- Some parts of the world that have shown significant improvements in daily calorie intake per capita are China(at least 1400 kcal per capita), some parts of Southeast Asia and Northern Africa. (with data - lowest band minus lowest band or highest band minus lowest band)
- Parts of the world that have shown the least improvements are found in Subsaharan Africa, mostly central, eastern and southern parts remained below avg of less than 2400kcal

Need a home tutor? Visit smiletutor.sg

- Some parts have remained the same
 - o Russia remains at 2800-2999kcal
 - o Uganda remains at 2200-2399kcal
- Some parts have shown decrease
 - o Madagascar, Chad, Central African Republic and Namibia

(ii) Account for the changes observed in part (i).

[5]

1m for each point.

- **Disposable income**
 - o The amount of income left to an individual after taxes have been paid
 - o More disposable income → greater purchasing power to consume a larger variety and amount of food
- **Technological factors**
 - o GR: HYVs lead to increase in crop yield/ irrigation increases arable land
 - o increase in food supply → lower prices therefore more affordable for both DCs and LDCs
- **Political**
 - o governments can ensure stability of food supply for the DCs
 - o they have the technology and finances to implement technology on a large scale therefore daily calorie intake remains high over the years
- **Globalisation** → more fast food chains → fast foods usually prepared with large amounts of oil, processed meat and chemicals
 - o well received by people due to its convenience, comfortable dining atmosphere and affordable price

(b) Fig. 9 shows a response to a physical limitation in food production.

- o Multiple cropping is a practice of growing 2 or more crops on a single piece of land at the same time
 - minimises the problem of pests, crops such as garlic, pepper and onions planted next to tomatoes OR
 - leguminous crops such as groundnut and soya bean have roots that are able to replenish nitrogen in the soil are planted next to non-leguminous crops to benefit from the nitrogen generated

(c) Explain how food shortages can be caused by social factors.

[4]

1m per point:

- Lack of accessibility
 - o Accessibility to food refers to how easily residents can reach the food that is available
 - o Transport facilities such as road and rail links must be made available so that food can be reached even by people who live far away from shops
 - o Accessibility depends on number and location of food outlets
 - Hence a lack of accessibility leads to food shortages
- Inadequate logistics of food distribution and storage
 - o Food distribution is movement of food from farms to retail outlets
 - o Depends on presence of good transport network
 - o Accessibility is affected due to physical barriers such as mountains or events such as landslides
 - o worsened by lack of storage facilities
 - o This affects stability of food supply and can cause food shortages
- Rapid population growth in LDCs
 - o due to lack of education and family planning
 - o food supply unable to meet the growing demand for food

(a) "The impacts of inadequate food consumption are more serious than excess food consumption."

To what extent do you agree with the statement? Support your answer using evidence. **[8]**

Level 1

Generic statements of political factors. Examples are very general. No discussion of one other factor.

Level 2

Definitions of terms are given

Explanation of impacts of inadequate food consumption and impacts of excess food consumption – very brief

Examples may be brief (name of country only) or no examples given.

Examples may not be relevant to DCs or LDCs

No evaluation in conclusion.

Level 3

Definitions of terms are given

Explanation of impacts of inadequate food consumption and impacts of excess food consumption

Both impacts are well-explained and precise

At least two precise examples

Both examples are relevant to DCs & LDCs

Evaluation made in conclusion

- 4 (a) Study Fig. 10, which shows the world's food security situation based on the global supply and demand conditions for grains.

Global Supply and Demand conditions for grains 2001 and 2012

	2001 (million tons)			2012 (million tons)		
	Output	Consumption	Net surplus/deficit	Output	Consumption	Net surplus/deficit
World	2,060	2,060	0	3,025	3,025	0
Developed countries	637	530	107	681	608	74
Less developed countries	1,424	1,530	-106	2,344	2,418	-74
• Middle-income countries	484	565	-81	1,133	1,194	-61
• Low-income countries	939	965	-26	1,211	1,223	-12

Fig. 10

Describe how far the food security situation for grains has changed between 2001 and 2012. [5]

- o Overall there is no change in food security situation for the world.
- o DCs: **there's food security** as supply/output exceeds demand/consumption for both years,
 - both years had surpluses, 2001: 107 mil tons and 2012: 74 mil tons
 - However, less food secure- net surplus for DCs has decreased by 33 mil tons
- o LDCs: **less food security** demand/consumption exceeds supply/output,
 - both years had deficits, 2001: deficit of 106 mil tons and 2012: deficit of 74 mil tons
 - food security situation has improved slightly, decreased in deficit of 32 mil tons
- o Middle income countries in LDCs have greatest shortage 2001: 81 mil tons and 2012: 61 mil tons (with data 1m)
 - However shortage decreased over the years for middle income countries (decreased from 16.7% to 5.4%)
- o Overall supply has increased faster than demand **in LDCs** to meet consumption needs, supply increased by 64% and demand increased only by 58%

- (b) Study Fig. 11, which is a climate map of Odisha, formerly known as Orissa, India and Fig. 12 (Insert), which is a photograph of a village in Odisha.

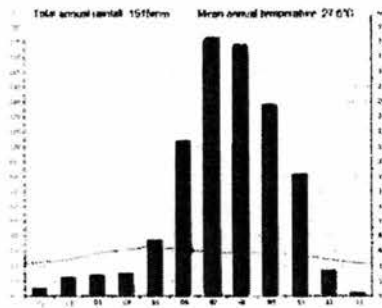

Fig. 11

Use Fig. 11 and Fig. 12 to explain the social and environmental factors that contribute to the spread of malaria in Odisha. [5]

Social factors:

- Lack of proper sanitation
 - Waste water is not disposed of properly as seen in the foreground of photograph due to lack of proper sanitation. Water from the pipes is not drained away or disposed of properly. Hence stagnant pools of water is formed.
 - Stagnant pools of water provides a favourable breeding ground for mosquitoes. When located close to settlements such as the rural village shown in the photograph, it increases the risk of people being infected with malaria.

Environmental factors:

- Effect of climate:
 - There is evidence of monsoons in Odisha, which creates favourable conditions for mosquitoes to breed in by bringing large amounts of rainfall. Between June to October, there is high rainfall of between 80 to 170mm of rainfall per month. This is followed by a period of low rainfall.
 - Pools of stagnant water would be left behind by the heavy rain→ provide favourable breeding grounds for mosquitoes
 - This is often due to blocked storm water drains caused by accumulation of debris
 - High temperatures→ Mean annual temperature is high at 27.6 degrees Celsius
 - High temperatures increase the lifespan of and frequency of bites by mosquitoes

- Higher temperatures shorten the development time of the parasites in the mosquito host. As a result, mosquitoes become active and infectious sooner.
- the aquatic life cycle of mosquitoes will be reduced from 20 days to 7 days when temperature decreases
- **Overcrowded living conditions** → Dwellings in the background seems to be built close to each other/ basic dwellings with no proper windows and doors to keep out Anopheles mosquitoes that tend to be active at night
 - the crowded living conditions also mean that mosquitoes can go easily from person to person

(c) Study Fig. 13, which is an excerpt of an article about the challenges of malaria prevention in less developed countries.

Effective control and treatment of malaria presents enormous logistical challenges. Malaria is a disease that stems from and causes poverty, and many at-risk populations live in extremely desolate, remote areas. Poor, rural families are the least likely to have access to the preventative measures that are fundamental to malaria control, and may live kilometres from the nearest healthcare facility.

Fig. 13

Use Fig. 13 to suggest the possible challenges to managing the spread of malaria in less developed countries.

- **Poverty** causes limitations in health care. Resistance to drugs is caused by the incomplete treatment of an infected person. This causes some of the surviving parasites to develop resistance to the drugs.
- **Poverty** also mean that there is a lack of resources to build necessary infrastructure for improved sanitation. A lack of drainage for example could lead to stagnant pools of water to be left behind after heavy rains.
- **Poor families** also would be unable to afford medical help which might be costly. Travel time to clinics may also mean families lose a day of work. The families may not get help to prevent forgoing a day of work.
- **Lack of accessibility:** nearest healthcare facility is very far away therefore, poor families may not be able to afford transportation to clinics.
- Poverty ⑦ lack of education hence lack of awareness

(d) Explain how malaria may limit the economic development of a country.

[4]

- Burden of malaria on households
 - Increased medical expenses
 - Economic costs include insecticide-treated nets, purchase for medication, travel expenses, lost income from days off from work for treatment, days lost from school, costs of implementing preventive measures

- Cost of health care
 - o Countries need to set aside funds for the provision of health care to address the disease
 - o The funds are used for costs such as building maintenance and investments in hospitals and clinics
 - o Less resources left aside for other areas of development such as education, infrastructure and public transport
- Loss of productivity
 - o People infected with malaria might not be able to work due to poor health. This results in loss of productivity of workforce
 - o Lower productivity results in slower economic growth

(e) 'Communities are more effective than governments in managing the spread of diseases.'

Do you consider this statement to be true? Explain your answer.

[8]

Level 1

Generic statements of communities. Examples are very general. 1 example given. No discussion of one other factor. No explanations of community (only examples given).

Level 2

Definitions of terms are given
 Explanation of community and one other role but very brief
 Examples may be brief (name of country only) or no examples given.
 Only success discussed, no limitations
 No evaluation in conclusion

Level 3

Definitions of terms are given
 Explanation of community and one other factor given
 Both factors are well-explained and precise
 At least two precise examples
 Success and limitations discussed for both points
 Evaluation made in conclusion

END OF PAPER

Acknowledgements

Fig. 1: <https://s-media-cache-ak0.pinimg.com/originals/33/0c/16/330c1686ce8412f78023040f59ac6689.jpg>

Fig. 2: http://year9scienceourchangingearth.weebly.com/uploads/3/1/9/3/31938515/3103378_orig.png

Fig. 3: <http://www.nytimes.com/interactive/2011/03/11/world/asia/maps-of-earthquake-and-tsunami-damage-in-japan.html#panel/0>

Fig. 4: <http://www.nytimes.com/interactive/2011/03/11/world/asia/maps-of-earthquake-and-tsunami-damage-in-japan.html#panel/0>

Fig. 5: <http://www.earthobservatory.sg/outreach/natural-hazard-outreach/west-sumatra-tectonics-and-tsunami-hazard>

Fig. 6: https://www.washingtonpost.com/news/worldviews/wp/2013/11/15/8-maps-that-explain-why-typhoon-haiyan-hit-the-philippines-so-hard/?utm_term=.d74d12145cde

Fig. 7: <http://www.npr.org/sections/thetwo-way/2013/11/14/244996256/images-of-tacloban-before-and-after-typhoon-haiyan>

Fig. 8: <https://ourworldindata.org/food-per-person/>

Fig. 9: <https://www.britannica.com/topic/terrace-cultivation>

Fig. 10: <https://ourworldindata.org/food-per-person/>

Fig. 11: <https://en.climate-data.org/location/2813/#climate-graph>

Fig. 12: <http://www.indiamike.com/india-images/pictures/tribal-village-near-onukdelli-orissa>

Fig. 13: <https://malariajournal.biomedcentral.com/articles/10.1186/1475-2875-8-S1-S2>

SmileTutor.sg



**Anglo-Chinese School
(Barker Road)**

PRELIMINARY EXAMINATION 2017

SECONDARY 4 EXPRESS / 5 NORMAL (ACADEMIC)

**GEOGRAPHY PAPER 2
(2236/02)**

1 HOUR 30 MINUTES

READ THESE INSTRUCTIONS FIRST

Write your name, class and register number on all the work you hand in.
Write in dark blue or black pen on both sides of the paper
You may use an HB pencil for any diagrams or graphs.
Do not use staples, paper clips, glue or correction fluid.

Section A

Answer **one** Question.

Section B

Answer **one** Question.

Write all answers on the Answer Paper provided.
Candidates are encouraged to support their answers with the use of relevant examples.
Sketch maps and diagrams should be drawn whenever they serve to illustrate an answer.

At the end of the examination, fasten all your work securely together.
The number of marks is given in brackets [] at the end of each question or part question.

Section A

Answer one question from this section.

- 1 (a) Study Fig. 1(a) and 1(b) which show the climographs of 2 different locations.

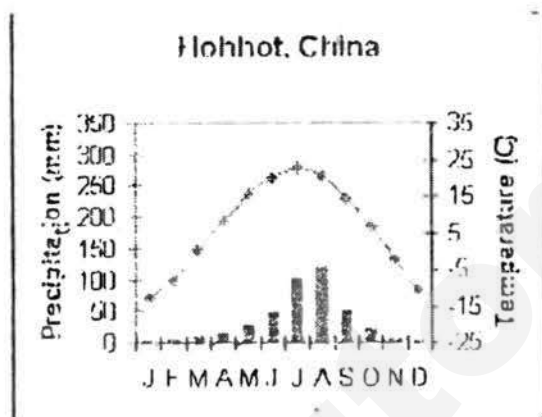

Fig. 1(a)

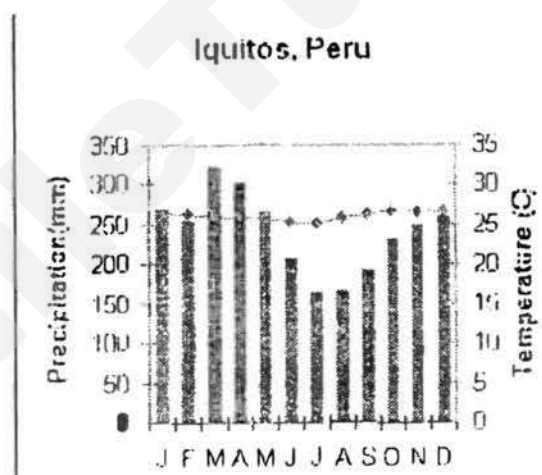

Fig. 1(b)

- (i) With reference to Fig. 1(a) and 1(b), compare the climographs of Hohhot and Iquitos. [4]
- (ii) Describe and explain the reasons for the differences in the temperatures of Hohhot and Iquitos. [5]

- (b) Study Fig. 2 which shows winds moving across the equator during the month of July.

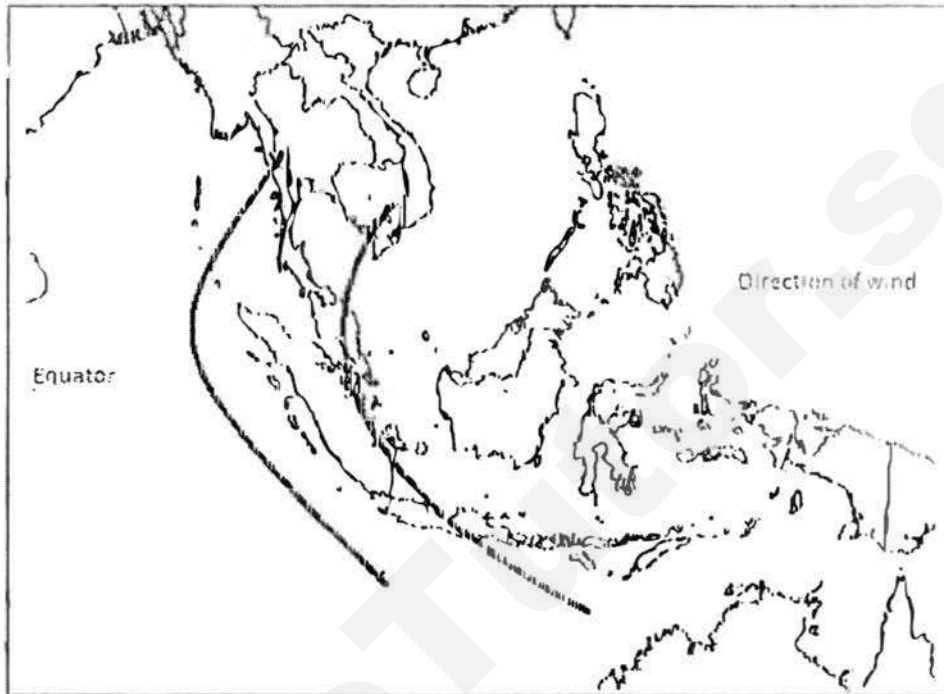

Fig. 2

- Using Fig. 2, explain the direction of the winds. [4]
- (c) Describe and explain how a land breeze is formed. [4]
- (d) 'Storm surges during a tropical cyclone cause the most damage to people and the environment.'
How far do you agree? Explain your answer with relevant examples. [8]

- 2 (a) Study Fig. 3 which shows how plate movement is caused.

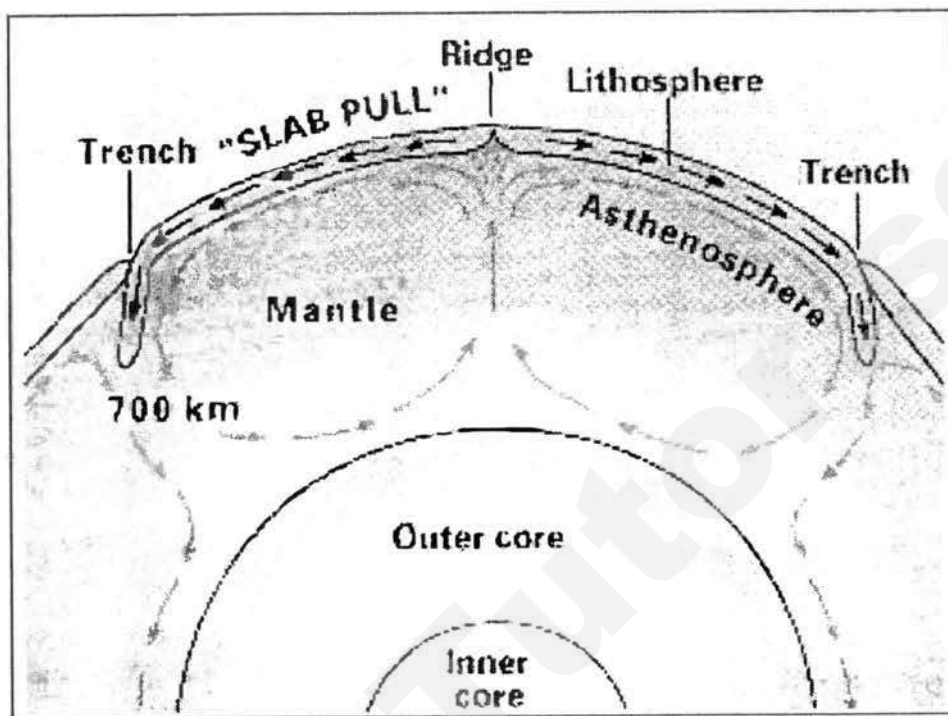

Fig. 3

Using Fig. 3, describe and explain how the slab pull force occurs.

[4]

- (b) Explain how volcanic materials cause massive destruction to the surrounding area during a volcanic eruption.

[4]

- (c) Study Fig. 4 which shows a graph with temperature and relative humidity (RH) data plotted over 24 hours.

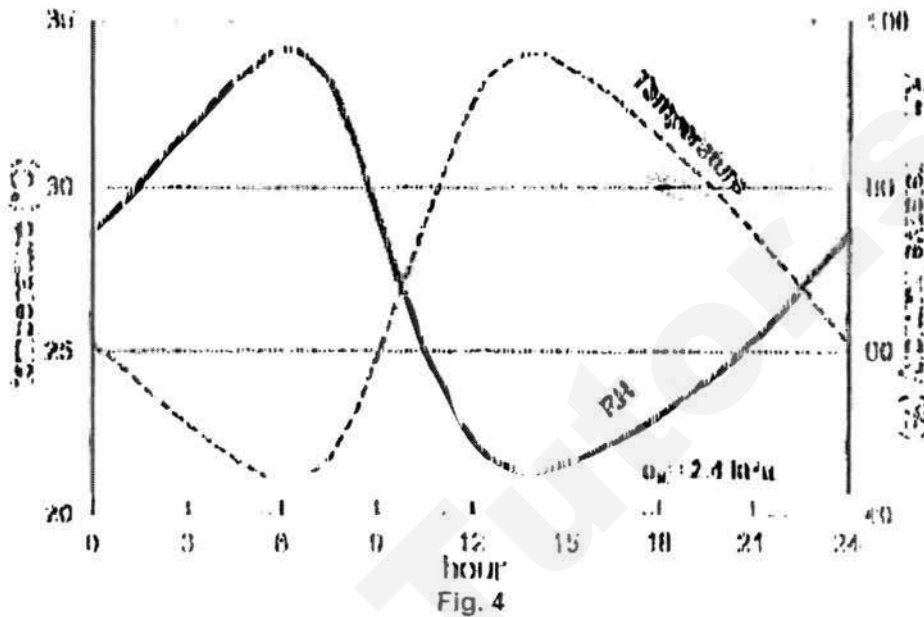

Using evidence from Fig. 4, describe and explain the relationship between temperature and relative humidity (RH).

[5]

- (d) Study Fig. 5 which shows an excerpt about a natural phenomenon.

The fact that Earth has an average surface temperature comfortably between the boiling point and freezing point of water, and thus is suitable for our sort of life, cannot be explained by simply suggesting that our planet orbits at just the right distance from the sun to absorb just the right amount of solar radiation. Our moderate temperatures are also the result of having just the right kind of atmosphere due to a natural phenomenon taking place.

Fig. 5

Identify the natural phenomenon discussed in Fig. 5 and outline its effect on Earth's atmosphere.

[4]

- (e) 'Recent climate change is more affected by natural causes than anthropogenic factors.'
To what extent do you consider this statement to be true? Give reasons to support your answer.

[8]

Section B

Answer ONE question from this section.

- 3 (a) Study Fig. 6 which shows the global demand for meat in 2005 and 2050.

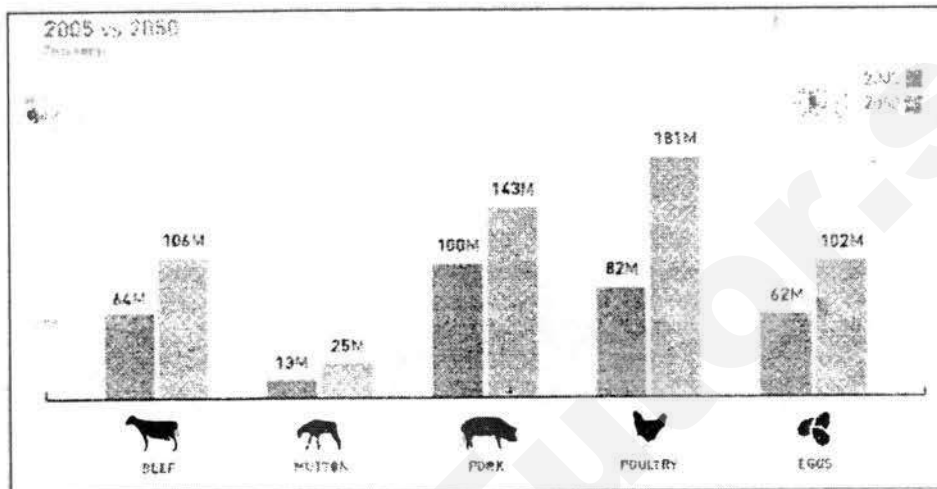

Fig. 6

Compare the changes in demand for meat between 2005 and 2050 and suggest reasons for the changes.

[5]

- (b) Using a relevant example, explain how inadequate food consumption caused political instability in a country.

[5]

- (c) Study Fig. 7 which shows the percentage of HIV-infected people engaged in selected stages of the continuum of HIV care

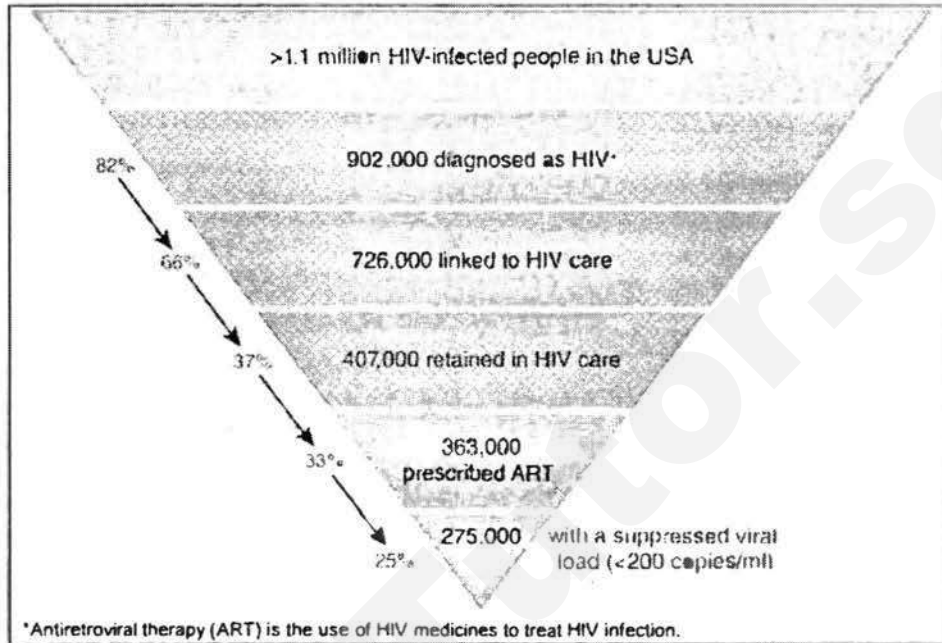

Fig. 7

Describe the changes seen in Fig. 7. Suggest reasons for the changes.

[4]

- (d) Study Fig. 8 which shows an online screenshot discussing one of the reasons for the re-emergence of malaria.

Drug Resistant Malaria a grave threat to Developing Countries

The emergence of resistance of *Plasmodium falciparum* to chloroquine, once a mainstay in the prevention of malaria, has led to a global resurgence of this disease

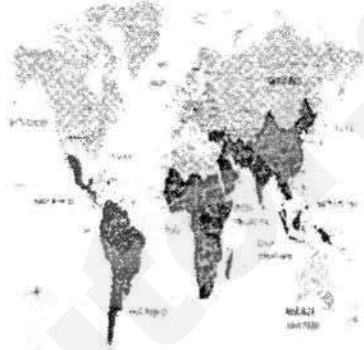

Fig. 8

With the help of information in Fig. 8, explain why there has been a global resurgence of malaria. [3]

- (e) 'Many countries like Singapore have been quite successful in implementing precautionary and mitigation measures when managing the spread of infectious diseases.'
How far do you agree? Support your answer with examples. [8]

- 4 (a) Study Fig. 9 which shows the price of staples in Singapore from 2007 to 2016.

Goods	2007	2016
Fresh milk (one-litre packet)	\$2.63	\$2.81 (▲ 6.8 per cent)
Infant milk powder (900g tin)	\$25.42	\$56.06 (▲ 120.5 per cent)
Cheese (pack of 12 slices)	\$3.89	\$4.56 (▲ 17.2 per cent)
Hen eggs (10)	\$1.69	\$2.17 (▲ 28.4 per cent)
Ordinary white bread (400g)	\$1.21	\$1.62 (▲ 33.9 per cent)
Thai fragrant rice (5kg)	\$7.87	\$13.13 (▲ 66.8 per cent)

Fig. 9

With the aid of Fig. 9, explain how Singaporeans' food preferences may change over time.

[4]

- (b) What are the differences between organic and non-organic food?

[5]

- (c) Study Fig. 10 which shows the estimated prevalence of diabetes in 2020.

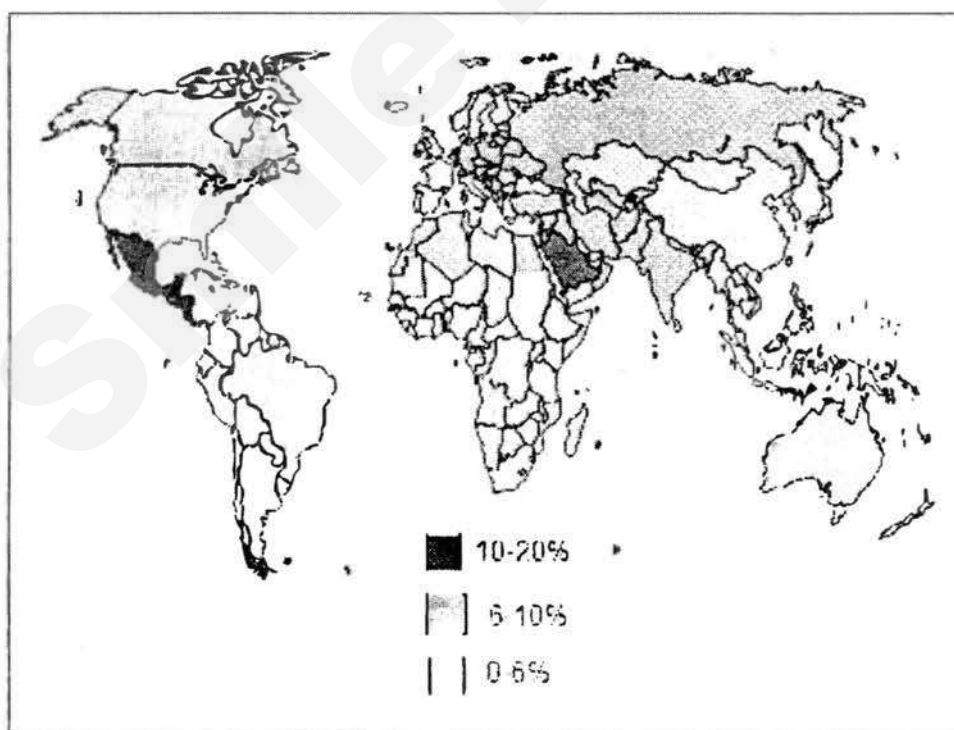
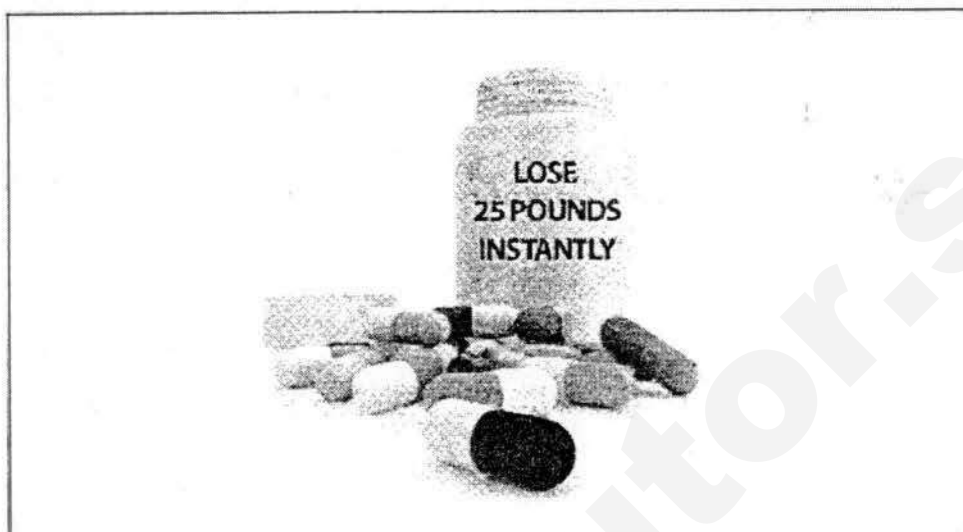

Fig. 10

Using Fig. 10, describe the global trend of diabetes estimated in 2020.

[3]

- (d) Study Photograph A which shows an impact on society due to excessive food consumption.



Photograph A

Describe the impact shown in Photograph A and explain its advantages related to a country's economy. [5]

- (e) 'Intensification of food production through irrigation and use of fertilisers and pesticides have many benefits and little negative consequences.'
How far do you agree? Give reasons to support your answer. [8]

END OF PAPER



Anglo-Chinese School (Barker Road)

PRELIMINARY EXAMINATION 2017

SECONDARY 4 EXPRESS / 5 NORMAL (A, A¹, A², A³, A⁴, A⁵)

GEOGRAPHY PAPER 2
(2236/02)

1 HOUR 30 MINUTES

READ THESE INSTRUCTIONS FIRST

Write your name, class and register number on all the work you hand in.

Write in dark blue or black pen on both sides of the paper.

You may use an HB pencil for any diagrams or graphs.

Do not use staples, paper clips, glue or correction fluid.

Section A

Answer one Question.

Section B

Answer one Question.

Write all answers on the Answer Paper provided.

Candidates are encouraged to support their answers with the use of relevant examples.

Sketch maps and diagrams should be drawn whenever they serve to illustrate an answer.

The Insert contains Fig. 1 and 2 for Question 1, Fig. 4 for Question 2, Fig. 6 for Question 3, and Fig. 7 for Question 4.

At the end of the examination, fasten all your work securely together.

The number of marks is given in brackets [] at the end of each question or part question.

This paper consists of 4 printed pages inclusive of this page.

Section A

Answer one question from this section.

- 1 (a) Study Fig. 1(a) and 1(b) which shows the climographs of 2 different locations.

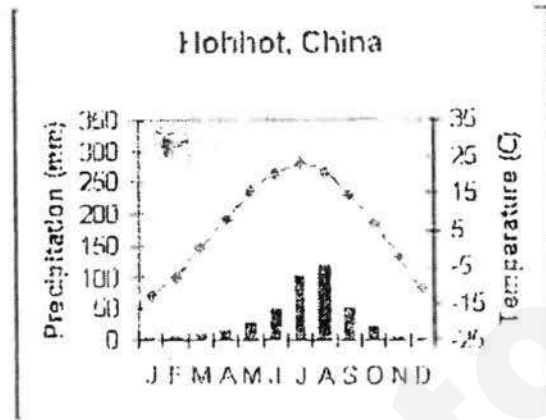

Fig. 1(a)

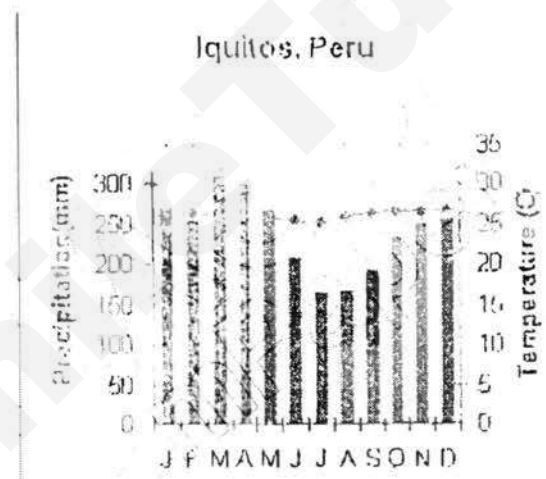

Fig. 1(b)

- (i) With reference to Fig. 1(a) and 1(b), compare the climographs of Hohhot and Iquitos. [4]

Precipitation

- Low throughout the year, with precipitation highest at 100mm
- High throughout the year, with precipitation highest at 325mm

Temperature

- Lowest at -10°C , highest at 25°C
- Stable at $25-28^{\circ}\text{C}$

Wet vs dry spells

(Evidence must be provided otherwise 0m)

(Accept any other relevant comparisons)

- (ii) Describe and explain the reasons for the differences in the temperatures of Hohhot and Iquitos. [5]

- Latitudes which result in different temperatures
- Angle of incidences which result in either more concentrated or less concentrated heat from sun
- Maritime vs Continental effect which affects temperature ranges
- If near the coast, the effect of large ocean bodies will cause small annual temperature range
- If inland, temperatures are not influenced by the sea, thus large annual temperature range

(b) Study Fig. 2 which shows winds moving across the equator during the month of July.

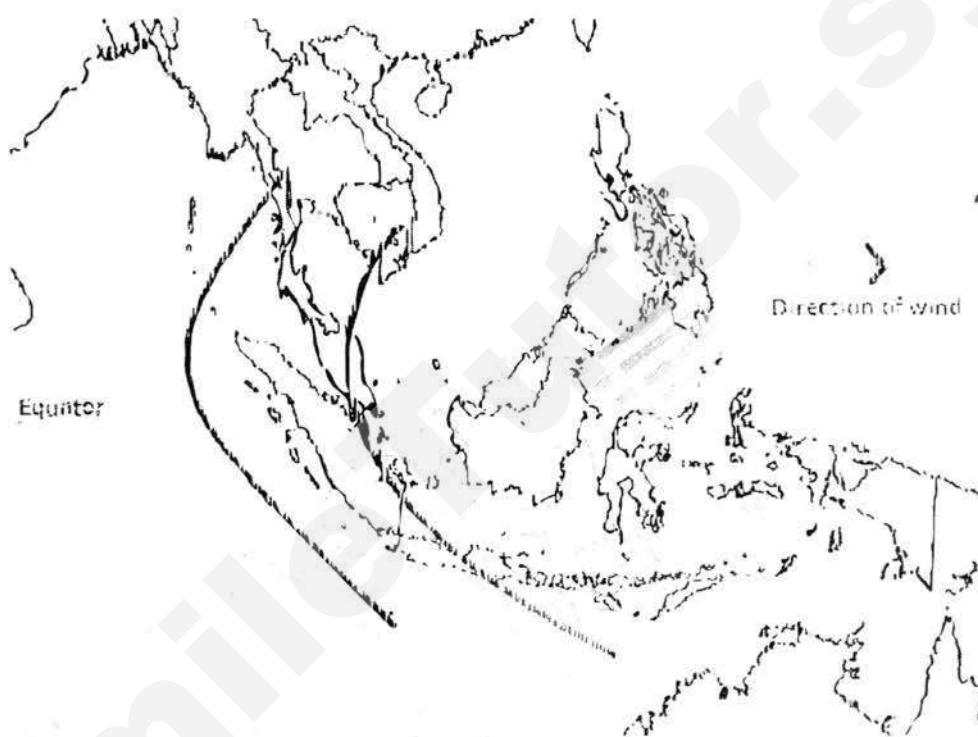

Fig. 2

Using Fig. 2, explain the direction of the winds.

[4]

- Air over Central Asia heats up, expands and rises, forming a warm region of low pressure over the area
- During the same period, the southern hemisphere experiences winter, the low temperature causes the air to be cold and dense, forming a cool region of high pressure over Australia
- Due to the difference in pressure, air from Australia moves to Central Asia as the southeast monsoon winds
- As the winds cross the Equator, the Coriolis effect deflects the winds to the right, which becomes the southwest monsoon winds

(c) Describe and explain how a land breeze is formed.

[4]

- Formed by differences in air pressure due to the different rates at which land and water bodies cool
- Land loses heat or cools down faster than water bodies at night

- As a result the sea has a higher temperature and lower air pressure than the land
- As air moves from an area of high pressure to an area of low pressure, it forms a land breeze that blows from the land to the sea at night

(d) 'Storm surges during a tropical cyclone cause the most damage to people and the environment.'

How far do you agree? Explain your answers with relevant examples.

[8]

1st para: storm surges (explain with e.g.)

(e.g.) Storm surges are sudden rises of sea level in which water is piled up against a coastline beyond the normal conditions at high tide. Strong winds then push the water towards the coast and create huge waves, giving rise to a storm surge. In 2008, Hurricane Ike caused a storm surge of between 4 and 6 metres above the normal tide level in Texas. It caused massive flooding which destroyed property, with damage estimated at US\$24.9b, and caused deaths. The surge might have also resulted in some vessels being swept in from the coast and stranded inland.

2nd para: strong winds (explain with e.g.)

(e.g.) Strong winds can damage or destroy infrastructure as well as injure people by causing loose debris to fly and hit people and buildings. In 1992, Hurricane Andrew attained strong winds of up to 177km/hr which caused widespread damage to the Bahamas and various parts of the United States of America. Damage to infrastructure disrupted power supply and left about 150000 homes without electricity.

3rd para: torrential rain (explain with e.g.)

(e.g.) Tropical cyclones produce torrential rain that can result in inland flooding. This sudden and large amount of rainfall adds to the flow of water in rivers and streams and causes them to overflow. In 2003, Hurricane Isabel flooded rivers that flowed across states of Virginia, Maryland, Delaware and Washington DC in the USA. The flooding affected areas about 120 times the size of Singapore and resulted in damage of more than US\$2.23b.

Probable conclusion:

Storm surges during a tropical cyclone cause huge damage to the people and the environment, nonetheless, they do more direct damage to coastal areas and seem to have reduced impacts on inland areas over time. However, impacts of strong winds and torrential rain seem to affect much larger areas than storm surges rather than just coastal areas, thus I do believe that these cause much more damage than storm surges.

2 (a) Study Fig. 3 which shows how plate movement is caused.

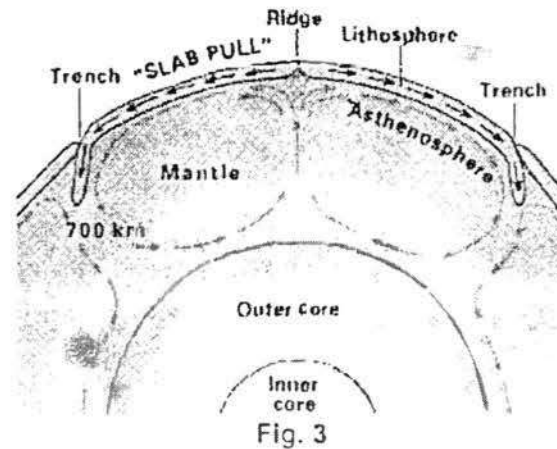

Using Fig. 3, describe and explain how the slab pull force occurs.

[4]

- Material in the mantle is heated by the core, causing the mantle material to expand, rise and spread out beneath the plates
- This causes the plates to be dragged along and to move away from each other
- Then the hot mantle material cools slightly and sinks at the trenches pulling the plates along
- Which results in the slab pull force as the dense, sinking oceanic plate at subduction zones pulls the rest of the plate behind it

(b) Explain how volcanic materials cause massive destruction to the surrounding area during a volcanic eruption.

[4]

- Volcanic materials include lava and pyroclasts that consists of ash, rock fragments and volcanic bombs which can lead to widespread damage of property
- Lava has high temperatures of between 500 to 1400°C and burns the area it flows through
- Pyroclastic flow can destroy everything in its path with hot rock fragments ranging from ash to boulders travelling at speeds greater than 200m/s
- Volcanic bombs of heated rocks can fall in areas surrounding the volcano and cause damage to property

(c) Study Fig. 4 which shows a graph with temperature and relative humidity (RH) data plotted over 24 hours.

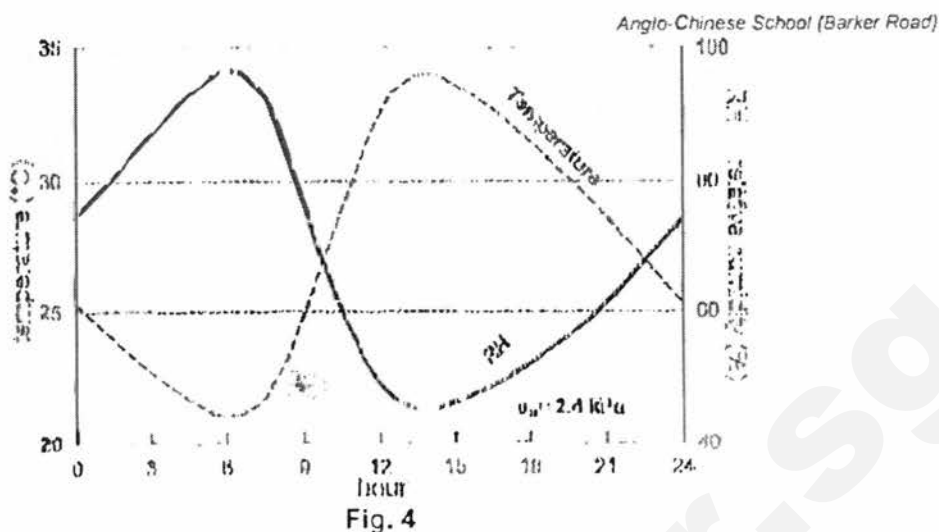

Using evidence from Fig. 4, describe and explain the relationship between temperature and relative humidity (RH). [5]

- Temperature has an inverse relationship with RH
- as temperature increases and decreases, RH decreases and increases respectively
- Warm air can hold more water vapour than cool air.
- When temperature increases during the 6-12 hour, the amount of water vapour in the air stays the same but the rise in temperature from 21°C to 34°C makes air more able to hold water vapour
- Thus RH decreases from 95% to 45% as temperature increases
(no use of evidence from figure = 0 m)

(d) Study Fig. 5 which shows an excerpt about a natural phenomenon.

The fact that Earth has an average surface temperature comfortably between the boiling point and freezing point of water, and thus is suitable for our sort of life, cannot be explained by simply suggesting that our planet orbits at just the right distance from the sun to absorb just the right amount of solar radiation. Our moderate temperatures are also the result of having just the right kind of atmosphere due to natural phenomenon taking place.

Fig. 5

Identify the natural phenomenon discussed in Fig. 5 and outline its effect on Earth's atmosphere. [4]

- Greenhouse effect
- Incoming solar radiation from the sun passes into the atmosphere
- Some re-radiated heat escapes into space but some gets reflected back by the presence of greenhouse gases
- which warms the atmosphere to sustain life on earth

(e) 'Recent climate change is more affected by natural causes than anthropogenic factors.' To what extent do you consider this statement to be true? Give reasons to support your answer. [8]

Point 1: Variations in solar output [explain with e.g. and link to question]

(e.g.) In 2000, a peak in the number of sunspots (170) coincided with high solar activity – global temperatures increased during this period

In 2009, when the number of sunspots reached its minimum (2) – global temperatures were the lowest

Point 2: Volcanic eruptions [explain with e.g. and link to question]

(e.g.) In 1991, eruption of Mount Pinatubo in the Philippines released 17m tonnes of sulphur dioxide into the atmosphere forming sulfur-based particles that spread around the earth in 2 weeks. The sulfur-based particles reflected solar energy back into space and lowered temperatures in the northern hemisphere by as much as 0.6°C and the temporary lowering of global temperatures lasted for 2 years in some locations. Change was not permanent as the volcanic dust and ash settled, global climate returned to its original state.

Point 3: Deforestation [explain with e.g. and link to question]

(e.g.) Between 2000 and 2010, 52000 km² of forest was lost every year. Greatest overall loss of forests occur in South America. Southeast Asia experiences the second highest rate of deforestation. The need for development like agriculture and commercial activities is the cause of forest clearance.

Point 4: Changing land use [explain with e.g. and link to question]

(e.g.) Large consumers of fossil fuels include China, the USA, Canada, and the United Kingdom. The world's usage of fossil fuels has increased in recent years, releasing billions of carbon dioxide into the atmosphere each year. In 2010, global carbon dioxide emissions totalled 30.6 billion tonnes, which was a 5.6% increase from 2009.

Probable conclusion:

It is true that recent climate change has been affected by both natural and anthropogenic causes. However, natural causes like huge volcanic eruptions, which do not happen on a daily basis, and solar output variations, which follow an 11 year cycle, seem to be less influential than anthropogenic factors like deforestation and land use changes, which appears to be around-the-clock activities. Thus, I would believe that recent climate changes could be attributed more to anthropogenic causes rather than natural ones.

- | | |
|--------------|--|
| L1
(0-3m) | <ul style="list-style-type: none"> • No attempt of question (0 marks) • No relevant examples were given • At least 1 main point was described and explained |
| L2
(4-6m) | <ul style="list-style-type: none"> • At least 1 relevant example was given for point made • At least 2 points were described and explained in detail |
| L3
(7-8m) | <ul style="list-style-type: none"> • At least 1 relevant example was given for points made • 3 points were described and explained in detail • Relevant examples were given for all points made |

Section B

Answer **ONE** question from this section.

- 3 (a) Study Fig. 6 which shows the global demand for meat in 2005 and 2050.

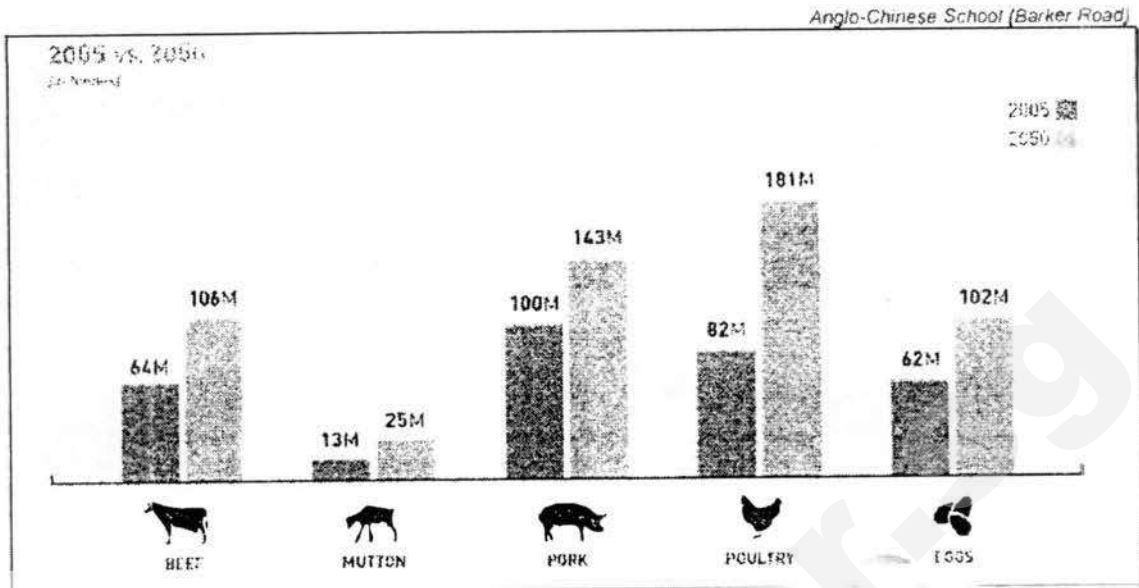

Fig. 6

Compare the changes in demand for meat between 2005 and 2050 and suggest reasons for the changes [5]

- 2005: highest to lowest – pork (100) poultry (82) beef (64) mutton (13)
- 2050: highest to lowest – poultry (181) pork (143) beef (106) mutton (25)
- Greatest changes: poultry (99) pork (43) beef (42) mutton (12)
- Chicken considered a more healthy meat as compared to the rest
- Chicken cheaper / more accessible

(accept any other relevant reasons)

(b) Using a relevant example, explain how inadequate food consumption caused political instability in a country. [5]

- Food prices in Mozambique increased by as much as 30% in 2010
- Caused by a drought in Russia that decreased its wheat production,
- which in turn increased the price of wheat sold to Mozambique
- Meaning that people had not enough money to buy a necessity, thus less to eat
- Resulted in violent protests leaving 400 injured and 10 dead

(c) Study Fig. 7 which shows the percentage of HIV-infected people engaged in selected stages of the continuum of HIV care

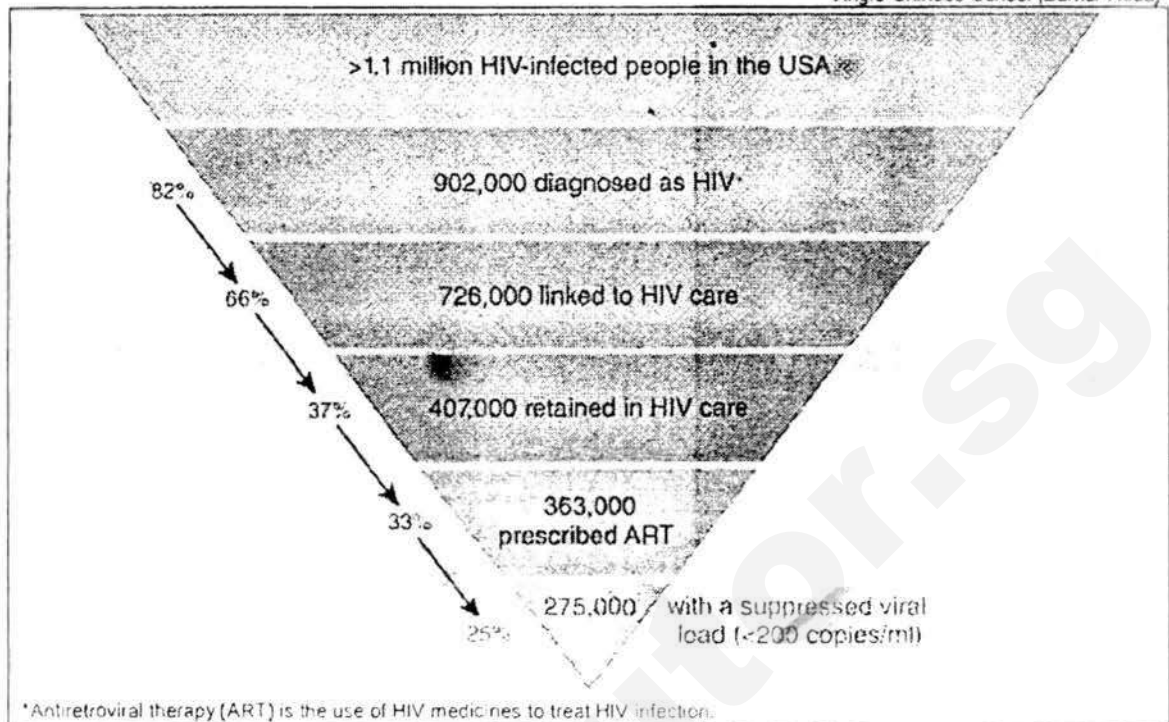

Fig. 7

Describe the changes seen in Fig. 7. Suggest reasons for the changes.

[4]

- Decreasing trend (state numbers and stages as evidence)
- Biggest drop from linked to HIV care to retained in HIV care (29%)
- Still stick to unsafe lifestyle choices so many still exposed to dangers
- Less social stigma related to disease so many more coming forward to receive treatment

(reasons should deal with both living with HIV and treatment)

- (d) Study Fig. 8 which shows an online screenshot discussing one of the reasons for the re-emergence of malaria.

Drug Resistant Malaria a grave threat to Developing Countries

The emergence of resistance of *Plasmodium falciparum* to chloroquine, once a mainstay in the prevention of malaria, has led to a global resurgence of this disease



Fig. 8

With the help of information in Fig. 8, explain why there has been a global resurgence of malaria. [3]

- Resistance to anti-malarial drugs have increased due to the rise in the use of counterfeit or incomplete doses of anti-malarial drugs
- Allows the surviving malaria parasites to build resistance to the drug
- Since the drugs did not kill all the parasites, making existing treatment ineffective against the hardened parasites

(e) 'Many countries like Singapore have been quite successful in implementing precautionary and mitigation measures when managing the spread of infectious diseases.'
How far do you agree? Support your answer with examples. [8]

P1: precautionary (describe + success + limitation+e.g.) Providing vaccinations against H1N1 (e.g.) In 2009, vaccinations provided for population against the H1N1 influenza virus before it emerged. More than 400 family clinics island-wide stocked with vaccines to allow access to prompt treatment. Most cases reported were mild, though there were 18 deaths still. However, vaccinations take up to 2 weeks to take effect and individuals may not want to receive them.

P2: mitigation (describe + success + limitation) Control measures during the SARS outbreak in 2003

(e.g.) People who were detected with SARS were isolated in a dedicated hospital. This was to prevent and control the spread by monitoring both staff and visitors. Potential patients were quarantined at home. These controls allowed the government to stem the spread and WHO approved of such measures and even encouraged other countries to follow suit. However, as some did not display symptoms of SARS till later, these people would have infected others without realising, thus negating the measures the government had put in

(b) What are the differences between organic and non-organic food?

[5]

- Fertilisers: organic vs chemical
- Crop yield: smaller vs larger
- Labour: more vs less
- Cost: expensive vs cheap
- Health: healthier vs less healthy

(Points above need to be described to have 1m)

(c) Study Fig. 10 (Insert) which shows the estimated prevalence of diabetes in 2020.

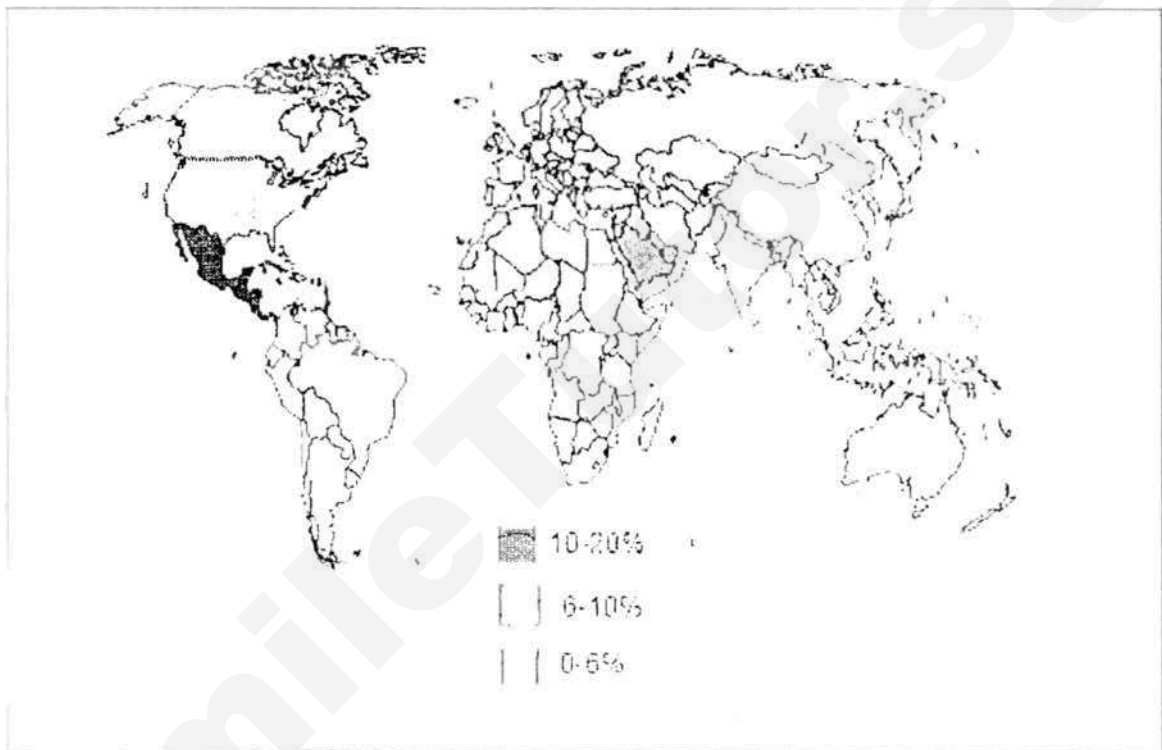

Fig. 10

Using Fig. 10, describe the global trend of diabetes estimated in 2020.

[3]

- 10-20%: only 1 area - SW of Middle East
- 6-10%: more seen in the Americas and Europe and Middle East
- 0-6%: seen mainly in South and Southeast Asia, Africa, Australia

(d) Study Photograph A which shows an impact on society due to excessive food consumption.

place.

P3: mitigation (describe + success + limitation) Singapore's National Environment Agency (NEA)'s 5-pronged approach to vector control (e.g.) By having a 5-pronged approach (surveillance, education, enforcement, research and regulation) to vector control, the NEA could reach out to the masses in many different ways, producing a safer environment in the process. WHO cited Singapore as a good role model in preventing and managing dengue cases for the number of such cases had decreased in recent years since the 2005 dengue fever outbreak in Singapore. Of course, there would be those that would be complacent about such approaches, creating problems for the authorities. The dengue virus would have since mutated as well, infecting people 2-3 days faster than the usual 7.

Probable conclusion

Many countries would have made strong attempts in implementing precautionary and mitigation measures in managing infectious diseases. In order for such measures to be successful, countries would have to take into account the different roles that have to be played by the community. Once all areas are covered, the measures can then be said to be stringent and effective against any infectious disease.

- | | |
|--------------|--|
| L1
(0-3m) | <ul style="list-style-type: none"> No attempt of question (0 marks) No relevant examples were given At least 1 main point was described and explained At least 1 relevant example was given for point made |
| L2
(4-6m) | <ul style="list-style-type: none"> At least 2 points were described and explained in detail At least 1 relevant example was given for points made |
| L3
(7-8m) | <ul style="list-style-type: none"> 3 points were described and explained in detail (precautionary and mitigation covered) Relevant examples were given for all points made |

- 4 (a) Study Fig. 9 which shows the price of staples in Singapore from 2007 to 2016.

Goods	2007	2016
Fresh milk (one-litre packet)	\$2.63	\$2.81 (▲ 6.8 per cent)
Infant milk powder (900g tin)	\$25.42	\$56.06 (▲ 120.5 per cent)
Cheese (pack of 12 slices)	\$3.89	\$4.56 (▲ 17.2 per cent)
Hen eggs (10)	\$1.69	\$2.17 (▲ 28.4 per cent)
Ordinary white bread (400g)	\$1.21	\$1.62 (▲ 33.9 per cent)
Thai fragrant rice (5kg)	\$7.87	\$13.13 (▲ 66.8 per cent)

Fig. 9

With the aid of Fig. 9, explain how Singaporeans' food preferences may change over time. [4]

- Shows food pricing increasing
 - (state any above example to show increase)
 - Singaporeans may buy less to consume
 - Or switch to cheaper options to satisfy needs
- (Accept any other relevant explanations)



Photograph A

Describe the impact shown in Photograph A and explain its advantages related to a country's economy. [5]

- People may become overweight due to excessive food consumption
- These people may choose to go on a diet in order to lose weight
- People who are dieting often also engage in physical exercise
- Dieting provides employment and value to an economy by creating jobs in the health sector through the publishing of diet books, sale of medication and medical procedures

(e) 'Intensification of food production through irrigation and use of fertilisers and pesticides have many benefits and little negative consequences.'

How far do you agree? Give reasons to support your answer. [8]

Para 1: irrigation (explain + e.g.)

(e.g.) in the North African country of Libya, the Great Man-made River is one of the most extensive irrigation projects in the world and has made it possible to grow crops in the Sahara Desert, increasing the amount of arable land and thus increasing food production

Para 2: fertilisers and pesticides (explain + e.g.)

(e.g.) pesticide Malathion was used widely in the 1980s to address a fruit fly problem in fruit orchards in California, USA. With the removal of pests, the crop is protected which in turn increases crop yield

Para 3: salinisation (explain + e.g.)

(e.g.) Murray-Darling Basin in Victoria, Australia where naturally occurring salts became concentrated in some parts due to human activities such as irrigation development and land clearing. With low rainfall and high evaporation rate due to heat, salinisation occurs.

L1

(0-3m)

- No attempt of question (0 marks)
- No relevant examples were given
- At least 1 main point was described and explained
- At least 1 relevant example was given for point made

L2

(4-6m)

- At least 2 points were described and explained in detail
- At least 1 relevant example was given for point made

L3
(7-8m)

- 3 points were described and explained in detail
- Relevant examples were given for all points made

- END OF PAPER-

SmileTutor.sg

Anglo - Chinese School
(Independent)



PRELIMINARY EXAMINATION 2017
YEAR FOUR EXPRESS

GEOGRAPHY CORE
PAPER 1

2236/01

Monday

7 August 2017

1 hour 40 minutes

INSTRUCTIONS TO CANDIDATES

Do not open this booklet until you are told to do so.

Write your Index Number on all the work you hand in. Write in dark blue or black pen on both sides of the paper. You may use an HB pencil for any diagrams or graphs. Do not use staples, paper clips, highlighters, glue or correction fluid.

Section A

Answer Question 1.

Section B

Answer **one** question.

Write all answers on the Answer Paper provided.

Candidates are encouraged to support their answers with the use of relevant examples. Begin each question on a fresh page. Leave a line after each part-question. Sketch-maps and diagrams should be drawn whenever they serve to illustrate an answer.

At the end of the examination, fasten all your work securely. The number of marks is given in brackets [] at the end of each question or part question.

This question paper consists of **9** printed pages, an Insert and an Answer Cover Sheet.

[Turn Over

Section A

This question is compulsory.

- 1 A group of students conducted fieldwork study at a beach resort in Bali, Indonesia during the school holidays. Fig. 1 shows part of the area of study.

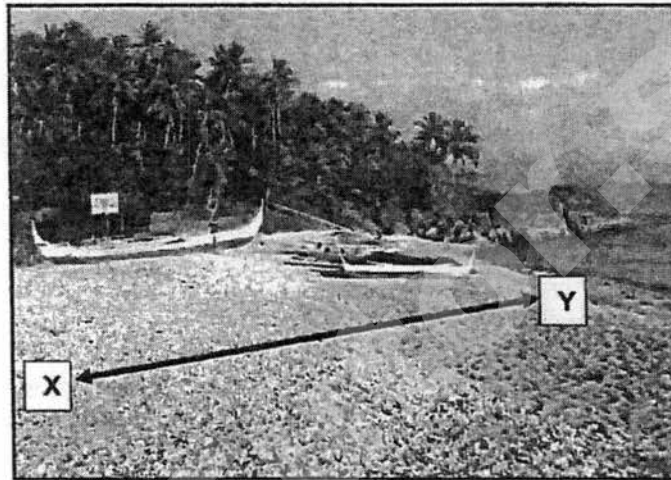

Fig. 1

- (a) They collected beach sediments along a line of transect labelled XY as shown in Fig. 1. Their hypothesis statement is 'The further the distance from the low tide mark, the larger the beach sediments.'
The data collected is shown in Fig. 2.

Distance from low tide mark (m)	0.5	1	1.5	2	2.5	3	3.5	4	4.5
Average length of long axis of sediment (mm)	1.5	2	2.5	5	2.5	3.5	4	4	4.5

Fig. 2

- (i) State some safety precautions that the students would need to take before proceeding for their investigations at the beach. [2]
- (ii) Describe, in detail, how the students collected the data in Fig. 2, using a quadrat and other instruments. [4]

[Turn Over

- (iii) Using data from Fig. 2, present the information, to show the relationship between distance from low tide mark and average length of long axis of sediment, on Fig. 3 on the Insert. [3]
- (iv) What conclusion can be drawn from Fig. 3 with reference to the hypothesis? [2]
- (v) Suggest some ways to improve the reliability of data collected. [2]
- (b) Another group of students conducted surveys by systematic sampling of 40 tourists on a Saturday morning in June. They interviewed tourists at location A, which is next to a hotel and location B, which is next to a local market.
They designed a questionnaire, as shown in Fig. 4, to investigate the hypothesis that **'The duration of stay in Bali is longer for tourists, above the age of 60'**.

Good morning. We are a group of students conducting Geography fieldwork. Can you please spare some time to answer a few questions? Thank you. _____

Q1: Age: below 20 / 21 to 40 / 41 to 60 / above 60 years old

Q2: How many days will you be in Bali? _____ days

Q3: What are your reasons for visiting Bali? (please circle)
business / visit relatives or friends / holiday / study /
others _____ (please specify)

Q4: What type of accommodation are you staying in? _____

Fig. 4

- (i) Which location, A or B, is better to select tourists to be interviewed? Justify your answer. [2]
- (ii) Suggest possible improvements to the Questionnaire in Fig. 4 to ensure relevance to the hypothesis that the students are testing. [2]

[Turn Over

(iii) The findings from the survey is shown in Fig. 5.

Age – group	Average length of stay (days)
below 20 years	8
21 to 40 years	4
41 to 60 years	7
above 60 years	5

Fig. 5

Evaluate the validity of the hypothesis: 'The duration of stay in Bali is longer for tourists, above the age of 60' by quoting evidence from Fig. 5.

[3]

(iv) State a limitation of the study and suggest how it can be improved.

[2]

(c) The students also investigated the impacts of visitors at the beach by conducting a perception survey as shown in Fig. 6. The results are shown in Fig. 7.

	-2	-1	0	+1	+2	
Lots of litter						Free from litter
Noisy						Quiet
Crowded						Few visitors
More traffic congestion						Few traffic congestion

Fig. 6

	Score
Cleanliness	+20
Noise level	-20
Human congestion	-10
Traffic congestion	-15

Fig. 7

Do the results in Fig. 7 suggest that the impacts of visitors have been largely positive? Explain your answer.

[3]

[Turn Over

Section B

Answer one question from this section.

- 2 (a) Study Fig. 8, which shows some factors why Singapore is a leading Meetings, Incentives, Conventions and Events (MICE) destination.

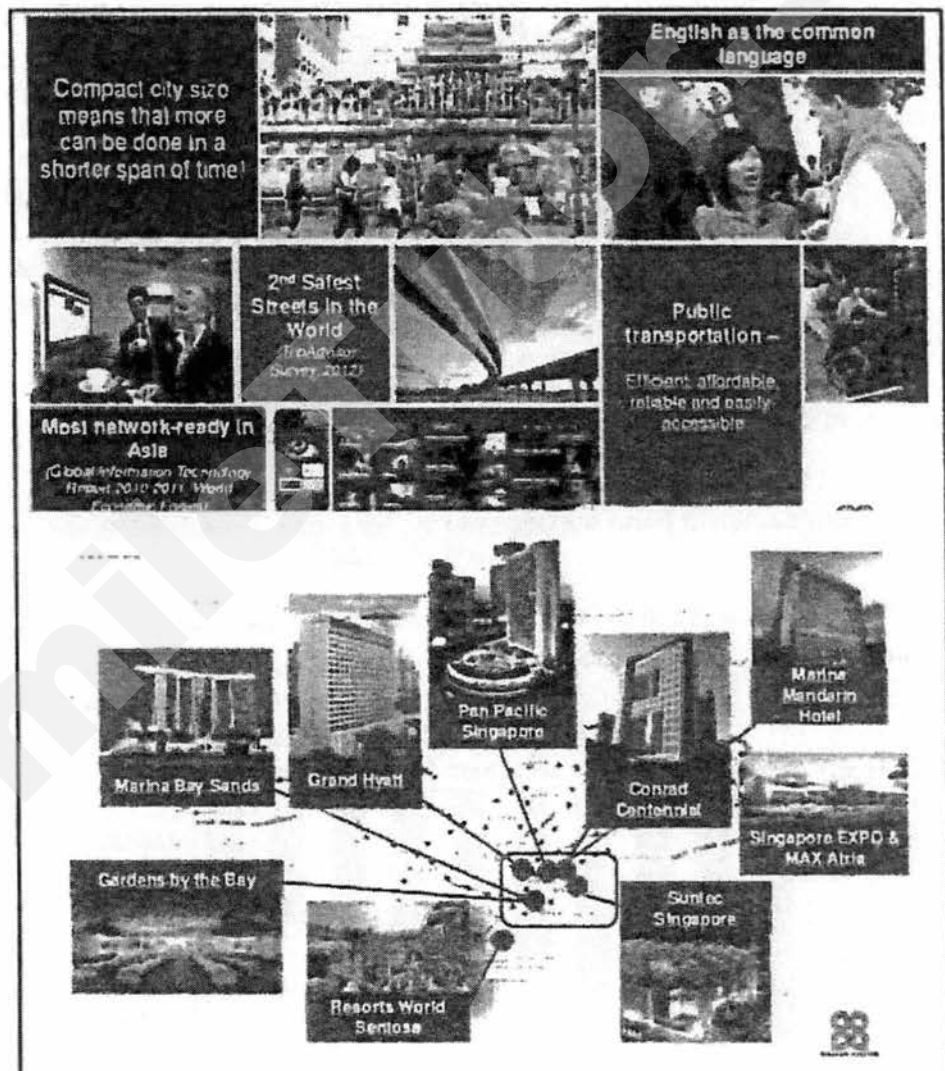

Fig. 8

(Source: <https://www.slideshare.net/MICEboard/singapore-presentation-mice-2014>)

With reference to Fig. 8 and studies you have made, identify and explain the reasons for this.

[5]

[Turn Over

- (b) Study Fig. 9, which shows some tourists on elephant rides in a river in Thailand.



Fig. 9

Explain how tensions might occur among different stakeholders involved in the tourist activity in Fig. 9 and suggest some strategies that the Thai government might use to minimise the tensions mentioned.

[4]

[Turn Over

7

- (c) Study Fig. 10, which shows international tourist arrivals and hotel room occupancy for Pattaya, Thailand from 2002 to 2011.

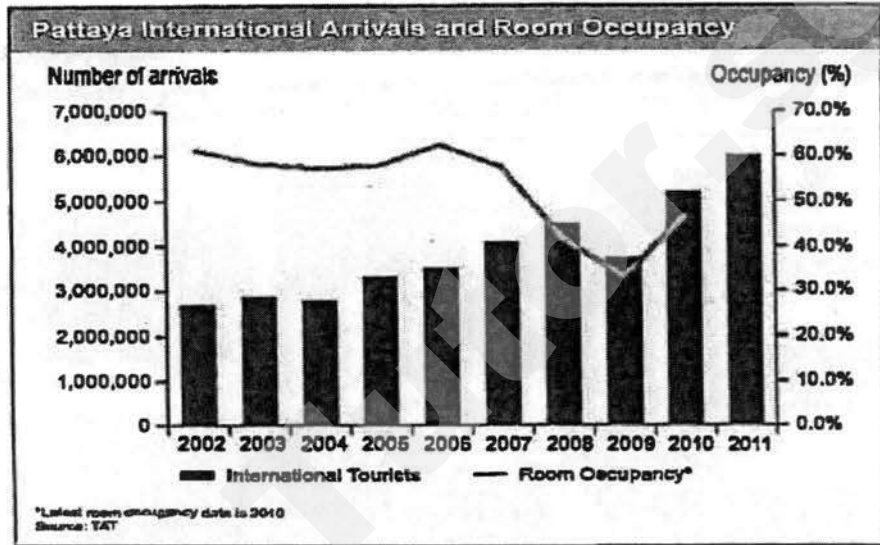

Fig. 10

(Source: http://powerhousedev.com/intl/wp-content/uploads/2013/08/0022_s9.jpg)

- (i) Using information from Fig. 10, describe the trend in international tourist arrivals and room occupancy from 2002 to 2010. [4]
- (ii) Explain how developments in technology promote the growth of tourism in Pattaya, Thailand. [4]
- (d) "Demand factors are more important than destination factors as the main reason for the growth of global tourism."

How far do you agree? Support your answer with examples. [8]

[Turn Over

Need a home tutor? Visit smiletutor.sg

- 3 (a) Study Fig. 11, which shows a coastal area.

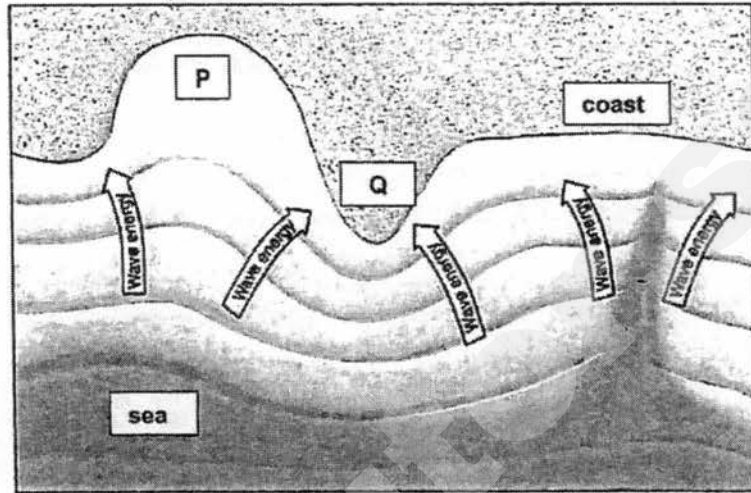

Fig. 11

With reference to Fig. 11, describe and account for the differences in the energy and frequency of waves at locations P and Q.

[4]

- (b) Study Fig. 12, which shows some houses at the edge of a cliff in England.

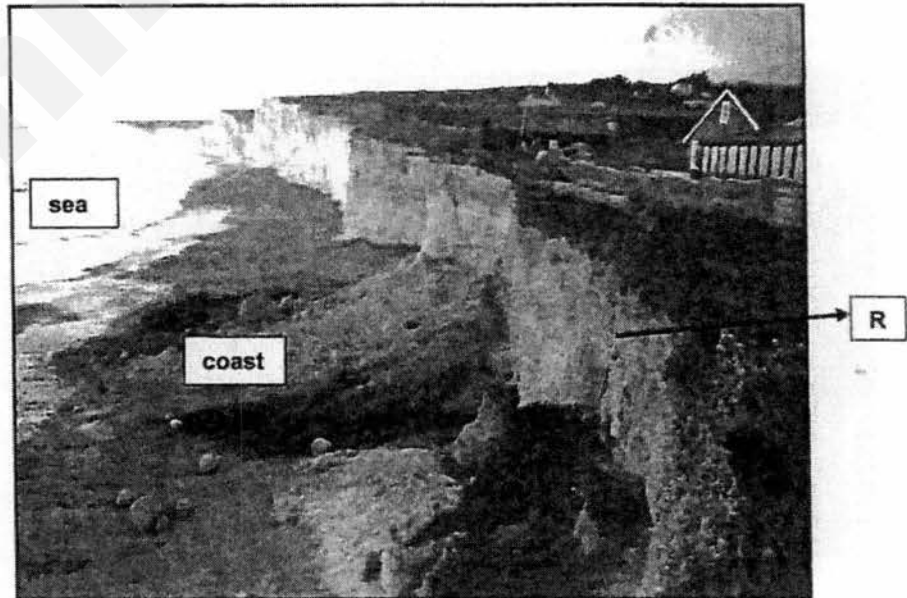

Fig. 12

[Turn Over

- (i) Describe the coastline shown in Fig. 12 and explain the stages in the development of the coastal feature R. [5]
- (ii) Outline two long-term protection measures that can help to manage the coastal area in Fig. 12. [4]
- (c) With the help of specific examples, explain any two factors that may lead to fluctuations in the tourism industry. [4]
- (d) "Areas with coral reefs and mangroves should be conserved mainly for tourism industry."
How far do you agree? Support your answer with examples. [8]

END OF PAPER

[Turn Over

Anglo - Chinese School
(Independent)



PRELIMINARY EXAMINATION 2017
YEAR 4 EXPRESS

ANSWER COVER SHEET

GEOGRAPHY CORE
PAPER 1

2236/01

Monday

7 August 2017

1 hour 40 minutes

Index Number: _____

Please indicate the Question Number attempted in the box below.

Question No	Marks obtained
1	
Total	/ 50

[Turn Over

INDEX NUMBER: _____

INSERT
(Please attach behind Answer Cover Sheet)

Fig. 3 for Question 1 (a) (iii)

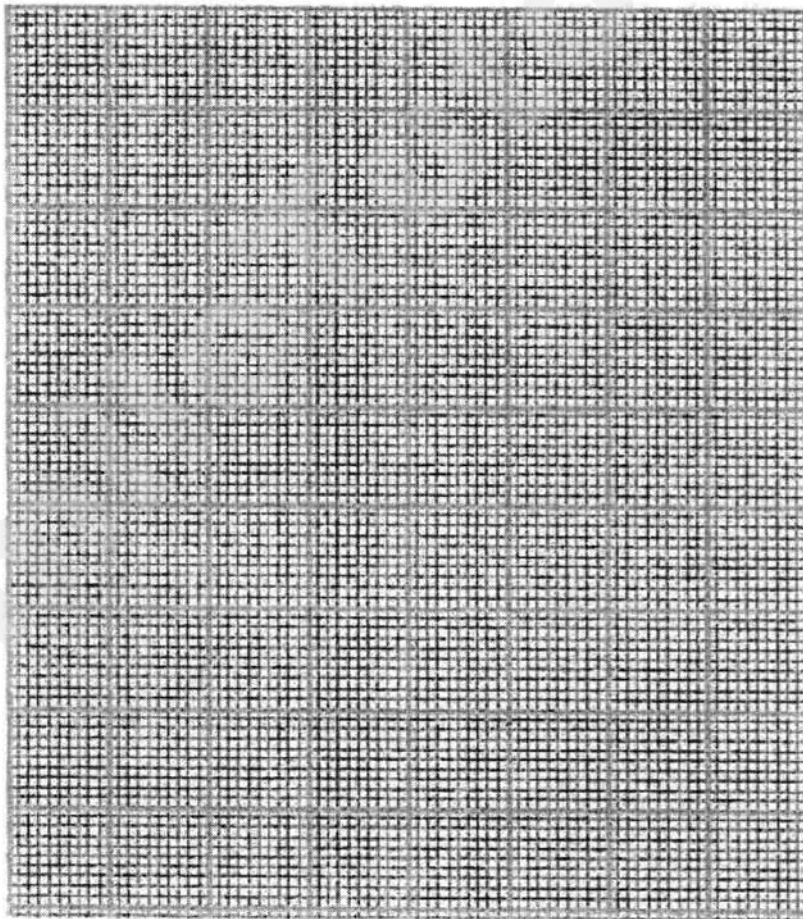

Anglo-Chinese School
(Independent)



PRELIMINARY EXAMINATION 2017
YEAR 4 EXPRESS

GEOGRAPHY
PAPER 2

2236/02

Friday

11 August 2017

1 hr 30 min

INSTRUCTIONS TO CANDIDATES

Do not open this booklet until you are told to do so.

Write your index number on all the work you hand in.

Write in dark blue or black pen on both sides of the paper.

You may use a soft pencil for any diagrams, graphs or rough working.

Do not use staples, paper clips, highlighters, glue or correction fluid.

Section A

Answer one question.

Section B

Answer one question.

Write all answers on the Answer paper provided.

Candidates should support their answers with the use of relevant examples.

Sketch maps and diagrams should be drawn whenever they serve to illustrate an answer.

At the end of the examination, fasten all your work securely together.

The number of marks is given in brackets [] at the end of each question or part question.

This question paper consists of 9 printed pages, 1 blank page and an Answer Cover Sheet.

[Turn over

Section A

Answer one question from this section.

1. (a) Study Fig. 1, a map showing the earth's tectonic plates and margins (boundaries).

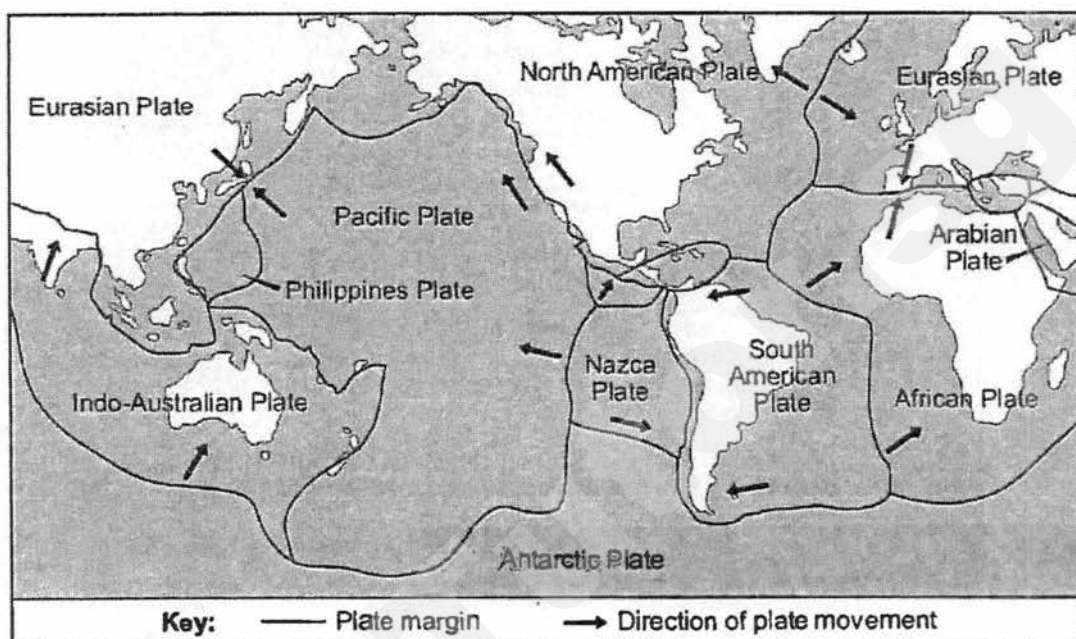

Fig. 1

(Source: David Waugh and Tony Bushell (2007) *New Key Geography for GCSE*, 2nd Edition, Nelson Thornes Ltd, UK)

- (i) With the help of Fig. 1, outline the differences between constructive and destructive plate margins. [3]
- (ii) With the aid of a labelled diagram, describe the formation of a composite volcano. [4]

- (b) Study Fig. 2, a map showing plate boundaries and areas affected by the Japanese tsunami of March 2011.

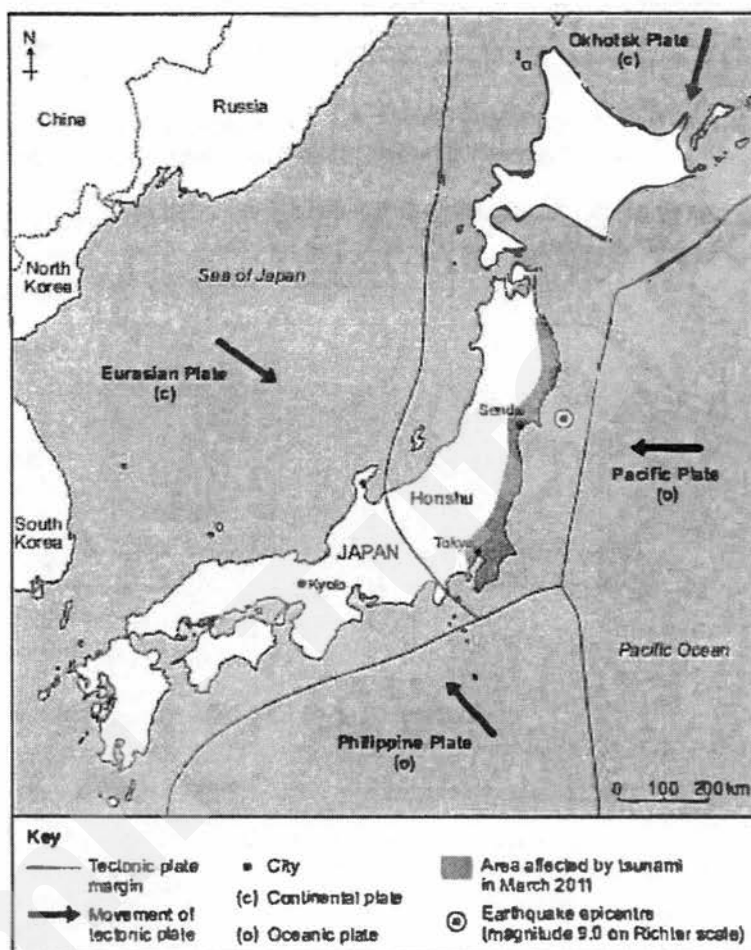

Fig. 2

(Source: USGS/2011 Tohoku Mag 9.0 Earthquake and Tsunami)

- (i) Using Fig. 2, suggest two reasons why it was difficult for people to escape from the tsunami in coastal areas of eastern Honshu. [2]
- (ii) With the help of Fig. 2, explain the likely cause of the tsunami in March 2011. [4]
- (iii) Describe the effect an earthquake and its resultant tsunami may have in Japan and the surrounding islands. [4]
- (c) 'Preparedness measures are the most effective in mitigating the impact of earthquakes and tsunamis.'
- Do you consider this statement to be true? Explain your answer. [8]

- 2 (a) Study Fig. 3 which shows the weather forecast for Singapore over a three day period in July.

	Wednesday July 12	Thursday July 13	Friday July 14
Overnight weather conditions	28°C Mostly Cloudy Slight chance of showers	27°C Mix of cloud and clear skies Chance of showers	27°C Mix of cloud and clear skies Chance of showers
Morning weather conditions	30°C Mix of cloud and sun Chance of showers	30°C Mix of cloud and sun Chance of showers	29°C Cloudy with sunny periods Chance of showers
Afternoon weather conditions	31°C Mix of cloud and sun Chance of thunderstorm	33°C Mix of cloud and sun Chance of thunderstorm	32°C Mix of cloud and sun Chance of thunderstorms
Evening weather conditions	30°C Mix of cloud and clear skies A few showers	29°C Mix of cloud and clear skies Chance of showers	30°C Mix of cloud and sun Chance of thunderstorms

Fig. 3

- (i) Identify the day with the lowest range of temperature and suggest how this is influenced by cloud cover. [3]
- (ii) Describe and explain the rainfall forecast in Singapore over the three days as shown in Fig. 3. [5]

- (b) Study Fig. 4, which is a map showing the distribution and strength of tropical storms.

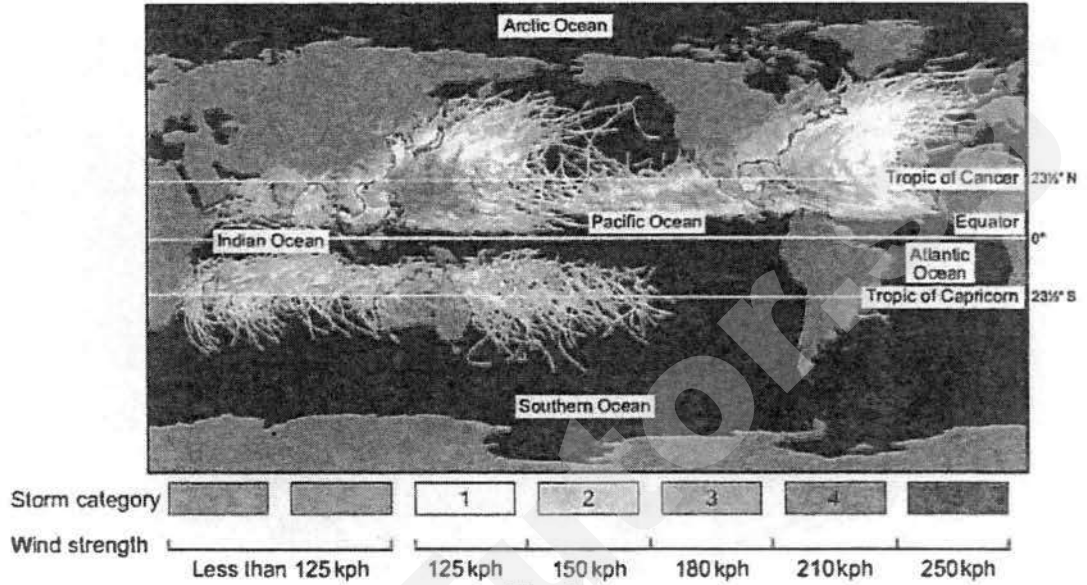

Fig. 4
(Source: NASA)

Using information from Fig. 4, describe the distribution of the tropical storms. [3]

- (b) Study Fig. 5 which shows the impact of Hurricane Sandy on selected states in the Eastern United States in 2012.

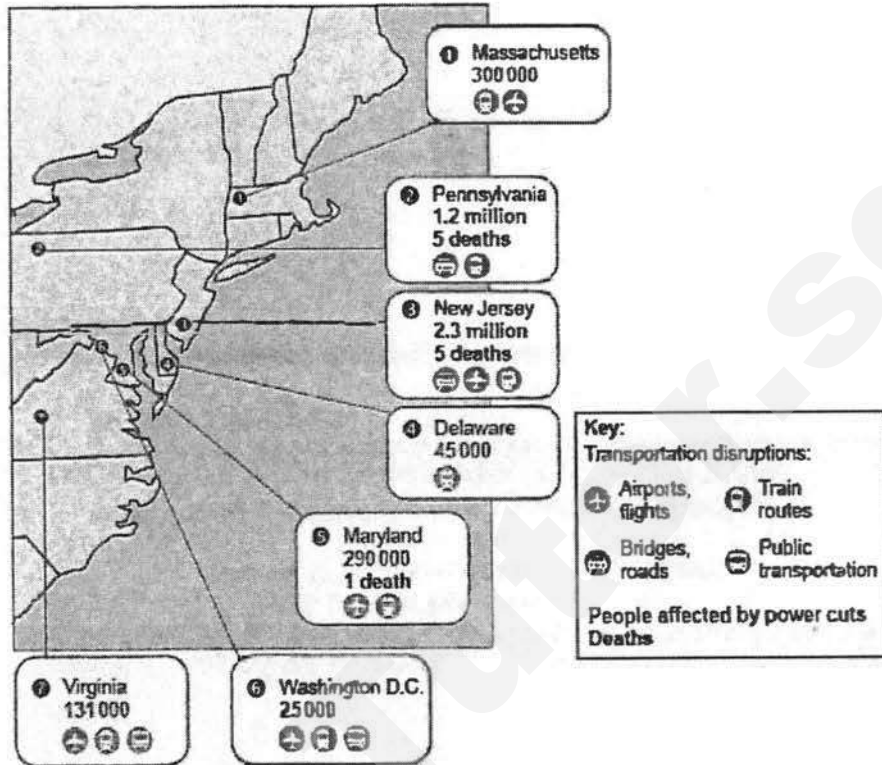

Fig. 5

- (i) Explain two conditions necessary for the formation of tropical cyclones. [4]
- (ii) With reference to Fig. 5, determine which state was the least affected by Hurricane Sandy, and provide a reason for your choices. [2]
- (c) With reference to examples of hazards you have studied, discuss why the highest magnitude events are not necessarily the most harmful. [8]

Section B

Answer one question from this section.

3. (a) Fig. 6 shows the spread of influenza (flu) in Kaien and Digby Islands.

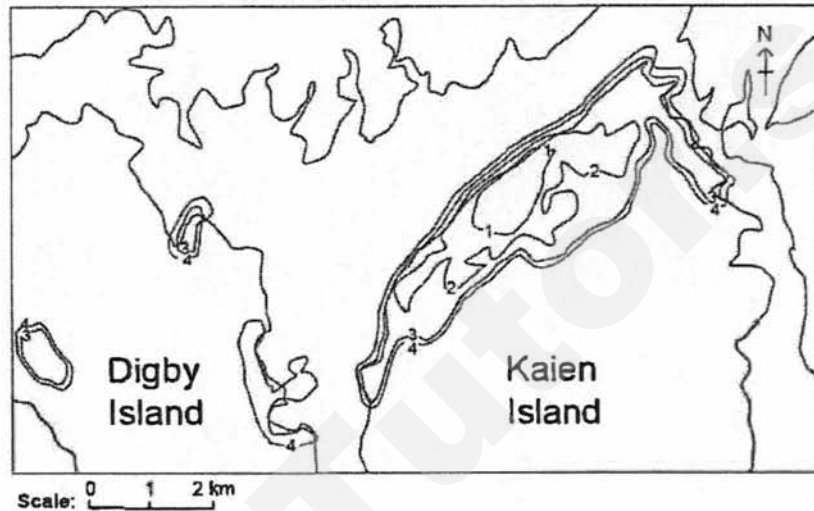

Fig. 6

- (i) Identify the type of diffusion shown on the map by the spread of flu in the first 2 weeks. [1]
- (ii) Identify the type of diffusion shown on the map by the spread of flu in week four to new areas such as the settlement of Digby Island. [1]
- (b) Fig. 7 shows deaths from coronary heart disease for the top 26 countries worldwide in 2005.



Fig. 7

- (i) Describe the pattern shown in Fig. 7. [4]
- (iii) Coronary heart disease is a type of degenerative disease. With reference to examples, contrast degenerative diseases with infectious diseases.

- (c) Fig. 8 shows the living conditions in a squatter settlement in a less developed country (LDC).

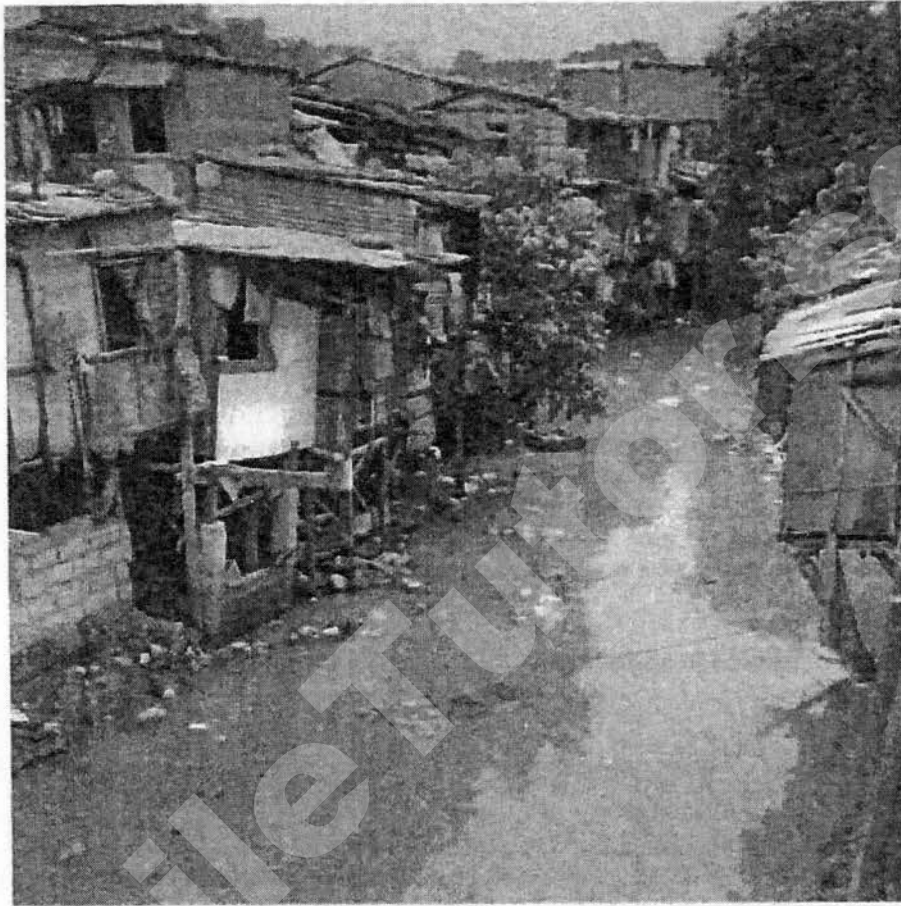

Fig. 8

(Source: © Getty Images/Marcus Lindstrom)

- (i) Identify **three** characteristics of this squatter settlement. [3]
- (ii) Suggest how **one or more** of the conditions shown affects the lives of the people living there. [4]
- (d) Evaluate the effectiveness of strategies introduced to address the problems of food shortage. [8]

- 4 (a) Study Fig. 9 which shows the percentage of people undernourished, by country, 2006 – 2008.

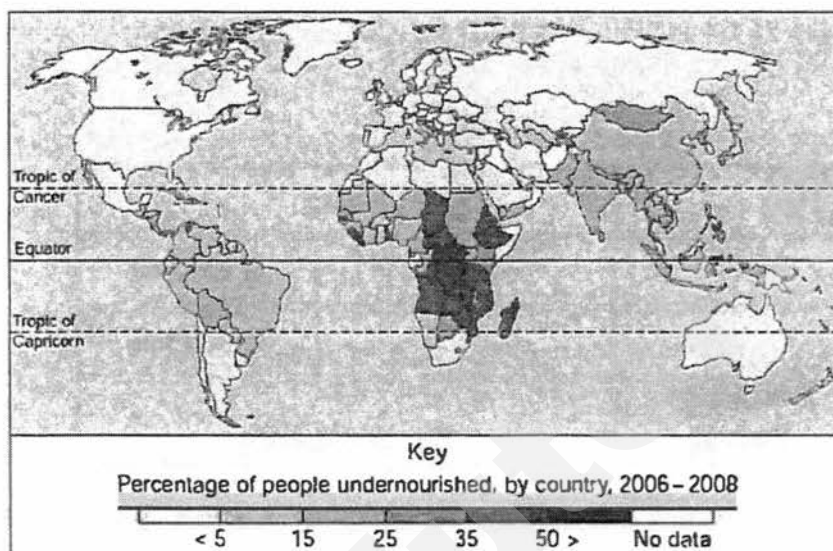

Fig. 9

(Source: Food and Agriculture Organisation of the United Nations, *Prevalence of Undernourishment in Total Population (%)*)

- (i) Describe the pattern of people undernourished shown in Fig. 9. [4]
- (ii) Describe the impact of inadequate food consumption. [5]
- (b) Study Fig. 10 which identifies the causes of food shortage and insecurity in Haiti.

Physical Factors	<ul style="list-style-type: none"> • Natural disasters worsen Haiti's situation. • In the 2008 hurricane season, 70% of Haiti's agriculture was destroyed. • The January 2010 earthquake, centred in Port-au-Prince, the capital and most populous city of Haiti killed about 20,000 people.
Economic factors	<ul style="list-style-type: none"> • Poverty: 76% of Haitians live on under US\$2 per day and 56% on under US\$1 per day. • 48% of Haiti's food is imported.
Other factors	<ul style="list-style-type: none"> • Multiple corrupt regimes. • High rates of HIV/AIDS.

Fig. 10

- Explain the factors which have contributed to food shortage and insecurity in Haiti. [5]
- (c) Chemical fertilisers are used to increase productivity of the land and crop yield. Describe the negative effects of the use of chemical fertilisers on the environment. [3]
- (d) Assess the success of technological factors to increase food supply. [8]

Anglo - Chinese School
(Independent)



PRELIMINARY EXAMINATION 2017
YEAR FOUR EXPRESS
GEOGRAPHY ELECTIVE

2267/02

Monday

7 August 2017

1 hour 40 minutes

Marking Scheme

This insert consists of 4 printed pages.

[Turn over

Section A

Answer one question from this section

1	<p>Some students in Adelaide, Australia, wanted to examine the impact of tourism on the Adelaide Central (shown on Photograph A, Insert), which is located in the city centre. Built in 1870, the Adelaide Central Market houses permanent stalls and shops in a covered structure. It is a popular destination for both locals and tourists.</p> <p>They first conducted a land-use survey of the market to determine the types of shops in the market and presented the data in a land-use map, shown in Fig. 1 (Insert).</p>																					
(a)	<p>Table 1 below is a tabulation of the various types of stalls in the market.</p>																					
	<p style="text-align: center;">Table 1 Types of land use in Adelaide Central Market</p> <table border="1" style="margin-left: auto; margin-right: auto;"> <thead> <tr> <th>Type of land use</th> <th>Number found</th> </tr> </thead> <tbody> <tr> <td>Fruits and vegetables</td> <td>16</td> </tr> <tr> <td>Meat and Seafood</td> <td>13</td> </tr> <tr> <td>Nuts/Coffee</td> <td>9</td> </tr> <tr> <td>Cafés</td> <td>6</td> </tr> <tr> <td>Bakeries</td> <td>?</td> </tr> <tr> <td>Services</td> <td>5</td> </tr> <tr> <td>Florists</td> <td>7</td> </tr> <tr> <td>Dairy products</td> <td>3</td> </tr> <tr> <td>Retail</td> <td>11</td> </tr> </tbody> </table>	Type of land use	Number found	Fruits and vegetables	16	Meat and Seafood	13	Nuts/Coffee	9	Cafés	6	Bakeries	?	Services	5	Florists	7	Dairy products	3	Retail	11	
Type of land use	Number found																					
Fruits and vegetables	16																					
Meat and Seafood	13																					
Nuts/Coffee	9																					
Cafés	6																					
Bakeries	?																					
Services	5																					
Florists	7																					
Dairy products	3																					
Retail	11																					
	<p>State the number of bakeries in the Adelaide Central Market.</p>	[1]																				
	<p>5</p>																					
(b)	<p>With reference to Fig.1, describe the distribution of the three most common land use in the covered Market.</p>	[3]																				
	<ul style="list-style-type: none"> • Fruits and vegetables shops are mainly located in the middle part of the market near to the two of the main exits as well as the escalator. • Similarly, the meat and seafood shops are located in the middle part of the market and near to the fruits and vegetables shops. • The fringe of the market consists mostly of retail shops. 																					
(c)	<p>The students came up with the following hypothesis:</p>																					
	<p><i>The income of the retail shops is most affected by seasonal changes in tourist numbers, while the income of the shops selling fresh food is least affected.</i></p>																					
	<p>Describe and justify a method that could be used to investigate this hypothesis.</p>	[4]																				
	<p>Max 2m for description</p> <ul style="list-style-type: none"> • Conduct interviews/questionnaires with the shops • Stratified sampling – students would need to interview a sample from both the two subgroups (retail shops and fresh food stores) • Questions on the shops' income during different times of the year/ percentage of income from tourists vs locals 																					

	<p>Max 2m for justification:</p> <ul style="list-style-type: none"> • The hypothesis involves two specific types of shops, so there must be a representative sample from each type • Questions on the shops' income are necessary as the hypothesis is about the economic impact of tourism 																															
(d)	<p>The students thought it might also be useful to examine tourists' perception of the Covered Market. Table 2 shows the results of the bipolar survey they conducted with some tourists.</p> <p style="text-align: center;">Table 2 Bipolar survey results on tourists' perception of the Covered Market</p> <table border="1" style="margin-left: auto; margin-right: auto;"> <thead> <tr> <th>Negative Factor</th> <th>Evaluative</th> <th>Score</th> <th>Positive Factor</th> <th>Evaluative</th> <th>Score</th> </tr> </thead> <tbody> <tr> <td>Small variety of shops and services</td> <td></td> <td>-16</td> <td>Wide variety of shops and services</td> <td></td> <td>+11</td> </tr> <tr> <td>Low quality of products and services</td> <td></td> <td>-4</td> <td>High quality of products and services</td> <td></td> <td>+23</td> </tr> <tr> <td>Few historical elements</td> <td></td> <td>-29</td> <td>Many historical elements</td> <td></td> <td>+8</td> </tr> <tr> <td>Much litter</td> <td></td> <td>-10</td> <td>No litter</td> <td></td> <td>+19</td> </tr> </tbody> </table>	Negative Factor	Evaluative	Score	Positive Factor	Evaluative	Score	Small variety of shops and services		-16	Wide variety of shops and services		+11	Low quality of products and services		-4	High quality of products and services		+23	Few historical elements		-29	Many historical elements		+8	Much litter		-10	No litter		+19	
Negative Factor	Evaluative	Score	Positive Factor	Evaluative	Score																											
Small variety of shops and services		-16	Wide variety of shops and services		+11																											
Low quality of products and services		-4	High quality of products and services		+23																											
Few historical elements		-29	Many historical elements		+8																											
Much litter		-10	No litter		+19																											
	(i)	Describe a suitable graph to present the information in Table 2.	[3]																													
		<ul style="list-style-type: none"> • Bipolar graph/ bar graph • Label the positive factors on one end and negative factors on the other • Lengths of bars correspond with the value of the factor <p><i>Sketch graphs are accepted; accurate graphs are awarded max 2m</i></p>																														
	(ii)	Suggest how the students could ensure the reliability of their data.	[2]																													
		<ul style="list-style-type: none"> • Conduct sampling of tourists e.g. systematic sampling of every 5th tourist • Conduct the survey at the busy areas where there are more tourists • Conduct a preliminary survey to test the questions before finalizing them • Conduct the interviews over a few more days to get more responses 																														

2	A group of students wanted to carry out an investigation in school to collect the rainfall and wind direction data. To extend their fieldwork, they decided to compare their results with measurements recorded at the local airport, about 45 km away from the school. The locations of the school and airport are shown in Fig. 2 (Insert).																																													
	<p>The rainfall and wind direction data collected in school.</p> <table border="1" data-bbox="435 347 1062 851"> <thead> <tr> <th>Day</th> <th>Rainfall (mm)</th> <th>Wind direction</th> </tr> </thead> <tbody> <tr><td>1</td><td>1</td><td>W</td></tr> <tr><td>2</td><td>1</td><td>W</td></tr> <tr><td>3</td><td>0</td><td>N</td></tr> <tr><td>4</td><td>1</td><td>NW</td></tr> <tr><td>5</td><td>0</td><td>W</td></tr> <tr><td>6</td><td>0</td><td>NW</td></tr> <tr><td>7</td><td>8</td><td>E</td></tr> <tr><td>8</td><td>12</td><td>SE</td></tr> <tr><td>9</td><td>1</td><td>NW</td></tr> <tr><td>10</td><td>6</td><td>S</td></tr> <tr><td>11</td><td>5</td><td>SW</td></tr> <tr><td>12</td><td>4</td><td>E</td></tr> <tr><td>13</td><td>7</td><td>SE</td></tr> <tr><td>14</td><td>6</td><td>SE</td></tr> </tbody> </table> <p style="text-align: center;">Fig. 3</p>	Day	Rainfall (mm)	Wind direction	1	1	W	2	1	W	3	0	N	4	1	NW	5	0	W	6	0	NW	7	8	E	8	12	SE	9	1	NW	10	6	S	11	5	SW	12	4	E	13	7	SE	14	6	SE
Day	Rainfall (mm)	Wind direction																																												
1	1	W																																												
2	1	W																																												
3	0	N																																												
4	1	NW																																												
5	0	W																																												
6	0	NW																																												
7	8	E																																												
8	12	SE																																												
9	1	NW																																												
10	6	S																																												
11	5	SW																																												
12	4	E																																												
13	7	SE																																												
14	6	SE																																												
	<p>The secondary data that students gathered about the weather condition at the airport.</p> <table border="1" data-bbox="465 918 1010 1417"> <thead> <tr> <th>Day</th> <th>Rainfall (mm)</th> <th>Wind direction</th> </tr> </thead> <tbody> <tr><td>1</td><td>3</td><td>SE</td></tr> <tr><td>2</td><td>1</td><td>W</td></tr> <tr><td>3</td><td>0</td><td>NW</td></tr> <tr><td>4</td><td>2</td><td>W</td></tr> <tr><td>5</td><td>0</td><td>E</td></tr> <tr><td>6</td><td>2</td><td>W</td></tr> <tr><td>7</td><td>11</td><td>SW</td></tr> <tr><td>8</td><td>15</td><td>SW</td></tr> <tr><td>9</td><td>2</td><td>N</td></tr> <tr><td>10</td><td>9</td><td>SW</td></tr> <tr><td>11</td><td>7</td><td>SE</td></tr> <tr><td>12</td><td>4</td><td>SE</td></tr> <tr><td>13</td><td>9</td><td>S</td></tr> <tr><td>14</td><td>7</td><td>S</td></tr> </tbody> </table> <p style="text-align: right;">Fig. 4</p>	Day	Rainfall (mm)	Wind direction	1	3	SE	2	1	W	3	0	NW	4	2	W	5	0	E	6	2	W	7	11	SW	8	15	SW	9	2	N	10	9	SW	11	7	SE	12	4	SE	13	9	S	14	7	S
Day	Rainfall (mm)	Wind direction																																												
1	3	SE																																												
2	1	W																																												
3	0	NW																																												
4	2	W																																												
5	0	E																																												
6	2	W																																												
7	11	SW																																												
8	15	SW																																												
9	2	N																																												
10	9	SW																																												
11	7	SE																																												
12	4	SE																																												
13	9	S																																												
14	7	S																																												
(a)	Identify the weather instrument used to determine the wind direction in Fig 3. [1]																																													
	Wind vane																																													
(b)	Calculate the average daily rainfall at the school and airport. [2]																																													
	<ul style="list-style-type: none"> • School: 3.71mm • Airport: 5.14mm 																																													
(c)	<p>Students wanted to test this hypothesis, 'There is more rainfall collected in school when the wind is blowing from the South.'</p> <p>How far does the data in Fig. 3 support the students' hypothesis? [3]</p>																																													
	<ul style="list-style-type: none"> • Only partially true. • Support- on the 10th day, when the wind is blowing from the south, the amount of rainfall collected in school is 6mm. • Does not support- Rainfall collected is usually greater when wind is blowing from the south-east. E.g. On the 8th, 13th and 14th day 																																													

	(d) With reference to Fig. 2 (Insert), Figs. 3 and 4, suggest reasons why rainfall is greater at the airport.	[4]
	<ul style="list-style-type: none"> • Airport is nearer to the sea/school further away from sea. Winds blowing from sea generally bring more rain. • More incidences of winds from S, SE and SW (from sea) at airport • Possible difference in altitude (airport higher above sea level) • Possible relief rainfall as Fig 3 shows an increase in height from 10 m to 50m which is the windward side of the mountain where the airport is located, thus it receives higher amount of rainfall. 	
	(e) Students wondered how they could improve the reliability of their results. Suggest some ways in which the accuracy and reliability of the results could be improved.	[3]
	<ul style="list-style-type: none"> • Conduct the study again over a longer period of time (more than 2 weeks). • Ensure readings are comparable at the two locations (e.g. time of readings taken). • Taking reading of rainfall at different seasons of the year. 	

6

Section B

Answer only one question

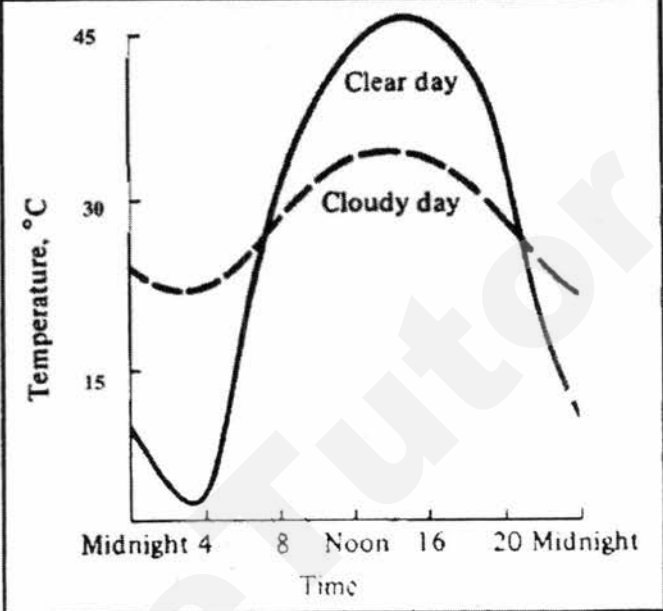
3	(a)	Study Fig.5, which shows how daily temperatures in Sahara Desert, North Africa can vary on a clear and a cloudy day.	
		<p style="text-align: center;">Temperatures in Sahara Desert on both Clear and Cloudy Days</p>  <p style="text-align: center;">Fig.5</p>	
		With reference to Fig.5, explain how cloud cover influences daily temperature range in Sahara desert.	[4]
		<ul style="list-style-type: none"> • As cloud cover decreases, daily temperature range increases. • From Fig. 5, daily temperature range on a cloudy day is about 10°C while that of a clear day is about 45°C. • On a clear day with little or no cloud cover, large amounts of heat reach the earth's surface, leading to very high day temperatures in the daytime (up to 46°C). With little cloud cover. • At night, large amounts of heat escape from earth's surface, leading to very low night temperatures (as low as -2°C). Hence, resulting in very large daily temperature range on cloudless days. 	
	(b)	<p>'Unfavourable political situations have greater effect on tourist arrivals than natural disasters.'</p> <p>How far do you agree with this statement? Support your answer with examples.</p>	[8]
		<p>Level 1 (0–3 marks) Answers are generalised or with minimal support if any given at all.</p>	

6

	<p>Reasoning rather weak and expression may be unclear. A basic answer that has little development. Answers lack examples or other evidence or, it is sketchy that it adds little support to the answer.</p> <p>Level 2 (4–6 marks) Disagreement or agreement is supported by appropriate detail. Or, both agreement and disagreement are considered, but support is patchy so that the answer is not full. Good reasoning and logic in parts of the answer with good expression in places. Some examples or other evidence will be presented to support answers in at least one place in the answer.</p> <p>Level 3 (7–8 marks) Answers are comprehensive and supported by sound knowledge. Both agreement and disagreement are considered and well-supported. Reasoning is clear and logical with good expression of language. Examples or other evidence to support answers are extensive. For L3 (8 marks), conclusion is well-explained and relative importance to be weighed to a criterion.</p>	
	<p><u>Possible Content</u></p> <p>Unfavourable political situation</p> <ul style="list-style-type: none"> • Unfavourable political situation such as political conflict, unstable government, acts of terrorism • May reduce tourist arrivals in a country or even region • Because it poses risk to tourists' safety and security • For example, three terrorist attacks hurt tourism in Indonesia generally, with overall visitor arrivals falling by nearly 31% in September 2002. Bali suffered the highest loss, down from 168,170 in September to 86,800 in October. • In 2002, the Bali bombing in Indonesia affected not only tourism industry in Indonesia but other Southeast Asian countries such as Malaysia, Singapore, Philippines and Thailand. <p><i>*Students can give other examples such as the gulf war,</i></p> <p>Natural disaster</p> <ul style="list-style-type: none"> • Natural disasters can cause great damage to properties and leading to injuries or great loss of life • Can reduce tourist arrivals • Because it poses greater risks to safety of tourists and may disrupt essential tourist infrastructure • E.g. <u>earthquake and tsunami in 2011 March, tourist arrivals in Japan had decreased by 28% to 6.2 million arrivals by end of 2011</u> <p><u>Possible arguments</u></p> <ul style="list-style-type: none"> • Students will need to explain clearly how it affected tourist arrivals (increase or decrease / same effect) – provision of data will be ideal as evidence • Students can evaluate in terms of <ul style="list-style-type: none"> - short-term or long-term effects on tourist arrivals - scale – effect on only a country's tourist arrivals or regional or global scale 	

- Another approach – students can explain how unfavourable political situations and natural disasters can decrease tourist arrivals in one place, but increase tourist arrivals in another.
- Weighing of the two given factors must be articulated.

4 (a) Study Fig. 6, which shows the relationship between distance from the sea and annual temperature range.

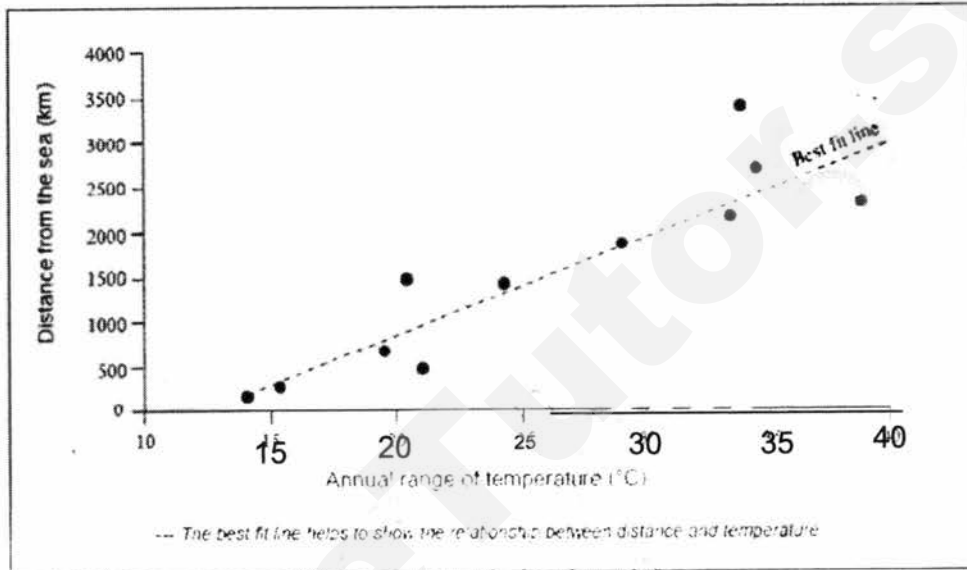

Fig. 6

With reference to Fig. 6, describe and explain the relationship between the distance from the sea and the annual temperature range.

[4]

Description

- The further the distance from the sea, the higher the annual range of temperature.
- Distance of 1428km from the sea experience a lower annual range of temperature of 24.4°C but a further distance of 2125km from the sea experience a higher annual range of temperature of 33.4°C.

Reasons

- Land heats up and cools down more quickly than the sea and coastal areas experience maritime effect with a smaller temperature range at an annual scale.
- Inland areas are affected by the continental effect which experiences a larger temperature range at an annual scale.

(b)	<p>'Strategies introduced by countries have been more effective in managing climatic change than international agreements.'</p> <p>How far do you agree with this statement? Support your answer with examples.</p>	[8]		
	<p>Level 1 (0–3 marks) Answers are generalised or with minimal support if any given at all. Reasoning rather weak and expression may be unclear. A basic answer that has little development. Answers lack examples or other evidence or, it is sketchy that it adds little support to the answer.</p> <p>Level 2 (4–6 marks) Disagreement or agreement is supported by appropriate detail. Or, both agreement and disagreement are considered, but support is patchy so that the answer is not full. Good reasoning and logic in parts of the answer with good expression in places. Some examples or other evidence will be presented to support answers in at least one place in the answer.</p> <p>Level 3 (7–8 marks) Answers are comprehensive and supported by sound knowledge. Both agreement and disagreement are considered and well-supported. Reasoning is clear and logical with good expression of language. Examples or other evidence to support answers are extensive. For L3 (8 marks), conclusion is well-explained and relative importance to be weighed to a criterion.</p>			
	<table border="1" style="width: 100%; border-collapse: collapse;"> <tr> <td style="width: 50%; padding: 5px;"> <p>Solutions by Countries</p> <p>Singapore</p> <ol style="list-style-type: none"> 1) Singapore Green Plan 2012 <ul style="list-style-type: none"> • Reduce energy consumption and greenhouse emission from burning fossil fuels 2) Green Mark Scheme <ul style="list-style-type: none"> • Constructing 'green' buildings 3) Plant-A-Tree programme <ul style="list-style-type: none"> • Planting more tree and plants </td> <td style="width: 50%; padding: 5px;"> <p>Solutions by International agreements</p> <p>Kyoto Protocol (1997)</p> <ul style="list-style-type: none"> • Kyoto Protocol: An international agreement to reduce greenhouse gases emission into the atmosphere. ◦ Drawn up on 11/12/97, came into effect 16/02/05 ◦ Different countries have different targets to hit and progress of carbon emissions will be tracked and reported for review. <p><u>Successes</u></p> <ul style="list-style-type: none"> • Many countries met or exceeded targets set by Kyoto Protocol as there was constant monitoring and reporting by countries for self and peer assessment. • Encouraged sustainable development. • Developed countries are encouraged to work with developing countries in carbon-reducing projects (Clean Development Mechanism — CDM) <p><u>Limitations</u></p> </td> </tr> </table>	<p>Solutions by Countries</p> <p>Singapore</p> <ol style="list-style-type: none"> 1) Singapore Green Plan 2012 <ul style="list-style-type: none"> • Reduce energy consumption and greenhouse emission from burning fossil fuels 2) Green Mark Scheme <ul style="list-style-type: none"> • Constructing 'green' buildings 3) Plant-A-Tree programme <ul style="list-style-type: none"> • Planting more tree and plants 	<p>Solutions by International agreements</p> <p>Kyoto Protocol (1997)</p> <ul style="list-style-type: none"> • Kyoto Protocol: An international agreement to reduce greenhouse gases emission into the atmosphere. ◦ Drawn up on 11/12/97, came into effect 16/02/05 ◦ Different countries have different targets to hit and progress of carbon emissions will be tracked and reported for review. <p><u>Successes</u></p> <ul style="list-style-type: none"> • Many countries met or exceeded targets set by Kyoto Protocol as there was constant monitoring and reporting by countries for self and peer assessment. • Encouraged sustainable development. • Developed countries are encouraged to work with developing countries in carbon-reducing projects (Clean Development Mechanism — CDM) <p><u>Limitations</u></p>	
<p>Solutions by Countries</p> <p>Singapore</p> <ol style="list-style-type: none"> 1) Singapore Green Plan 2012 <ul style="list-style-type: none"> • Reduce energy consumption and greenhouse emission from burning fossil fuels 2) Green Mark Scheme <ul style="list-style-type: none"> • Constructing 'green' buildings 3) Plant-A-Tree programme <ul style="list-style-type: none"> • Planting more tree and plants 	<p>Solutions by International agreements</p> <p>Kyoto Protocol (1997)</p> <ul style="list-style-type: none"> • Kyoto Protocol: An international agreement to reduce greenhouse gases emission into the atmosphere. ◦ Drawn up on 11/12/97, came into effect 16/02/05 ◦ Different countries have different targets to hit and progress of carbon emissions will be tracked and reported for review. <p><u>Successes</u></p> <ul style="list-style-type: none"> • Many countries met or exceeded targets set by Kyoto Protocol as there was constant monitoring and reporting by countries for self and peer assessment. • Encouraged sustainable development. • Developed countries are encouraged to work with developing countries in carbon-reducing projects (Clean Development Mechanism — CDM) <p><u>Limitations</u></p>			

		<ul style="list-style-type: none"> • Not all countries are able to meet their goals and not all countries have the same emission targets. • Denmark, Sweden and the United Kingdom did not achieve their targets • Many countries did not sign the Kyoto Protocol and continue to contribute to global emissions. • A large portion of the increase in global emissions came from China, India and the United States of America 	
	<p>India</p> <p>1) National Urban <u>Transport</u> Policy (NUTP) - Emphasising public transport</p> <p>2) Energy Labelling Programme for <u>appliances</u> - Reducing energy consumption and greenhouse emissions from burning fuels</p> <p>3) Indian Network of Climate Change Assessment (INCCA) - <u>research</u> - Promoting India-specific climate change research</p>	<p>Copenhagen Conference (2009)</p> <ul style="list-style-type: none"> • Held in Denmark, hosted the United Nations Climate Change Conference to build upon measures developed in previous conferences for addressing climate change. <p><u>Successes</u></p> <ul style="list-style-type: none"> • Allow countries to discuss measures to deal with climate change effectively, including improvements to CDM. • International agreement to keep increase in global temperature to below 2°C. • Pledges were made and developed countries pledged to; • Reduce greenhouse gas emissions by 2020. • Provide US\$30 billion for developing countries to fight climate change. <p><u>Limitations</u></p> <ul style="list-style-type: none"> • Lack for concrete plans on how to reduce greenhouse gases • Copenhagen Accord (Agreement) was not adopted by all countries. • The Accord was a guideline and no countries will be binded/punished if they do not fulfill their pledges. 	

Section C

Answer one question from this section.

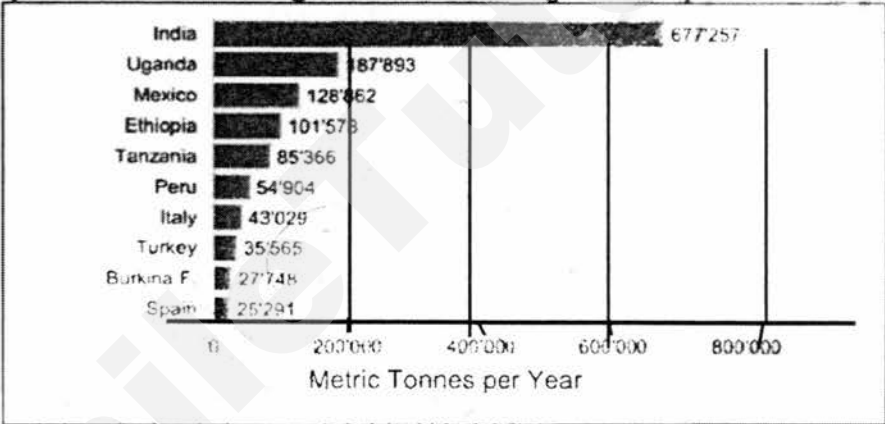
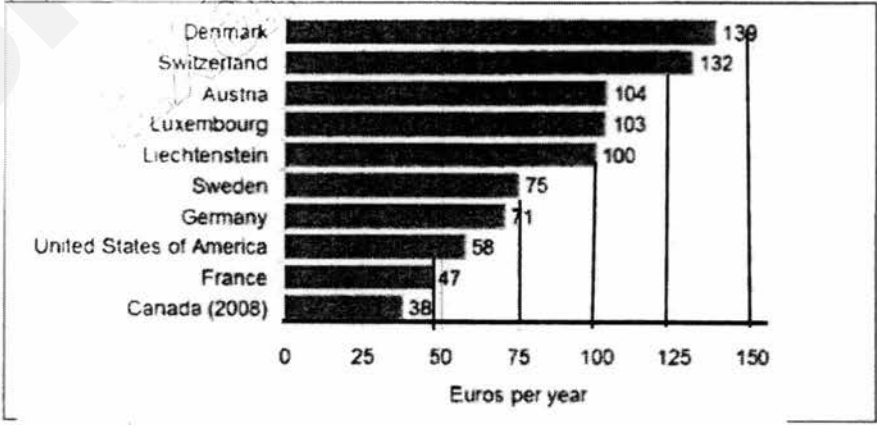
5	(a)	<p>Explain how climate change could affect food production. [4]</p> <ul style="list-style-type: none"> • Changes in climate may cause existing farmland to become unsuitable for farming while in certain areas that were not suitable for farming in the past. • Climate change may bring about extreme weather events such as tropical cyclones which could lead to the flooding of farmland which could destroy the crops. • Climate change may also bring about extreme weather events such as drought which would reduce the water supply needed for crops to grow properly, hence reducing crop yields. • Climate change may cause glaciers to melt, and this could cause the fresh water supply of rivers to be reduced or discontinued as it floods the low-lying areas. Without sufficient water supply, farming productivity is likely to be reduced. 																																													
	(b)	<p>Study Figs. 7 and 8, which show the top ten countries in the world in terms of production and consumption of organic food respectively in 2009.</p> <p>Top ten countries with highest numbers of organic food producers in 2009</p>  <table border="1"> <thead> <tr> <th>Country</th> <th>Metric Tonnes per Year</th> </tr> </thead> <tbody> <tr><td>India</td><td>677,257</td></tr> <tr><td>Uganda</td><td>187,893</td></tr> <tr><td>Mexico</td><td>128,862</td></tr> <tr><td>Ethiopia</td><td>101,578</td></tr> <tr><td>Tanzania</td><td>85,366</td></tr> <tr><td>Peru</td><td>54,904</td></tr> <tr><td>Italy</td><td>43,029</td></tr> <tr><td>Turkey</td><td>35,565</td></tr> <tr><td>Burkina F.</td><td>27,748</td></tr> <tr><td>Spain</td><td>25,291</td></tr> </tbody> </table> <p>Fig. 7</p> <p>Top ten countries with the highest per capita consumption of organic food in 2009</p>  <table border="1"> <thead> <tr> <th>Country</th> <th>Euros per year</th> </tr> </thead> <tbody> <tr><td>Denmark</td><td>139</td></tr> <tr><td>Switzerland</td><td>132</td></tr> <tr><td>Austria</td><td>104</td></tr> <tr><td>Luxembourg</td><td>103</td></tr> <tr><td>Liechtenstein</td><td>100</td></tr> <tr><td>Sweden</td><td>75</td></tr> <tr><td>Germany</td><td>71</td></tr> <tr><td>United States of America</td><td>58</td></tr> <tr><td>France</td><td>47</td></tr> <tr><td>Canada (2008)</td><td>38</td></tr> </tbody> </table> <p>Fig. 8</p>	Country	Metric Tonnes per Year	India	677,257	Uganda	187,893	Mexico	128,862	Ethiopia	101,578	Tanzania	85,366	Peru	54,904	Italy	43,029	Turkey	35,565	Burkina F.	27,748	Spain	25,291	Country	Euros per year	Denmark	139	Switzerland	132	Austria	104	Luxembourg	103	Liechtenstein	100	Sweden	75	Germany	71	United States of America	58	France	47	Canada (2008)	38	
Country	Metric Tonnes per Year																																														
India	677,257																																														
Uganda	187,893																																														
Mexico	128,862																																														
Ethiopia	101,578																																														
Tanzania	85,366																																														
Peru	54,904																																														
Italy	43,029																																														
Turkey	35,565																																														
Burkina F.	27,748																																														
Spain	25,291																																														
Country	Euros per year																																														
Denmark	139																																														
Switzerland	132																																														
Austria	104																																														
Luxembourg	103																																														
Liechtenstein	100																																														
Sweden	75																																														
Germany	71																																														
United States of America	58																																														
France	47																																														
Canada (2008)	38																																														

	<p>Contrast between the production and consumption of organic food in the countries shown in Figs. 7 and 8 and explain why this is so.</p>	<p>[5]</p>
	<p>Contrast:</p> <ul style="list-style-type: none"> The major producers of organic food are typically LDCs such as India and Uganda (except Italy and Spain), while the main consumers are typically DCs such as Denmark and Switzerland. <p>Explanation for LDC producers:</p> <ul style="list-style-type: none"> The producers are typically LDCs as they tend to be agriculturally-dependent economies. The farmers there are keen to increase their incomes by farming food for export to meet external demand, hence they grow organic crops which are increasingly popular in the DCs. DCs, on the other hand, often face higher production costs, which reduces their ability to compete with LDCs, and hence are less able to compete with countries like India. <p>Explanation for DC consumers:</p> <ul style="list-style-type: none"> The DCs tend to be the ones consuming most of the organic produce as they tend to have higher incomes, and thus can afford the more expensive organic food OR LDCs tend to have lower incomes, and hence lower purchasing power and less ability to buy relatively expensive organic food. Their higher levels of education and economic development also means DC consumers tend to be more concerned about health and nutrition, and therefore prefer organic food for their perceived food safety and health benefits. OR LDCs tend to be more concerned about ensuring sufficient food to avoid malnutrition and/or starvation, hence food quality is often of less concern 	
<p>(c)</p>	<p>Study Fig. 9, which shows the impacts of agribusiness in Nigeria in Africa.</p>	
	<p>IMPACTS Of Agribusiness Public-Private Partnerships in Africa</p> <p>NIGERIA INVESTMENT: \$30,000,000 COMMODITY: RICE</p> <p>INCREASED PRODUCTIVITY PRODUCED 3.25 tonnes per hectare</p> <p>COMPARED WITH The natural average of 1.25 tonnes per hectare</p> <p>Increased Farm Earning FROM \$235 per hectare TO \$235 per hectare</p> <p>DOUBLED FARMERS NET INCOMES THEN NOW</p> <p>INCREASED FARM CAPACITY FROM 18,000 tonnes per year TO 36,000 tonnes per year</p> <p>INCREASED PROFITABILITY BY 250% AFTER</p>	
		<p>[4]</p>
	<p>With reference to Fig. 9, explain how agribusiness contributes to the positive impacts in farming in Nigeria.</p>	

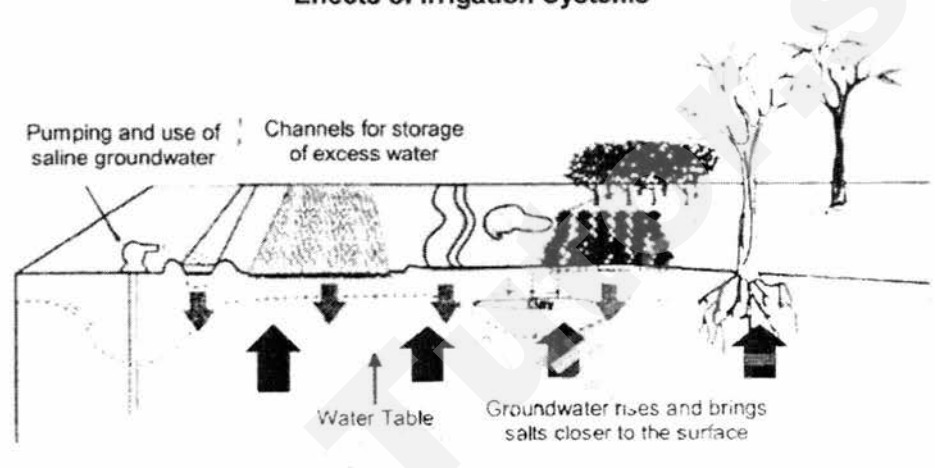
	<ul style="list-style-type: none"> • Increased productivity of 3.25 tonnes per hectare led to increased farm earnings from \$235 per hectare to \$1000 per hectare. • This in turn doubled the farmers' income. • The farm capacity and productivity has increased from 18000 tonnes per year to 36000 tonnes per year. • Thus the productivity rate of the farm has increased by 250% as compared to the past. 	
(d)	<p>Study Fig. 10, which shows the effects of irrigation systems on soil and water quality.</p>	
	<p style="text-align: center;">Effects of Irrigation Systems</p>  <p style="text-align: center;">Fig. 10</p>	
	<p>With reference to Fig. 10, discuss the effects of irrigation systems on the soil and water quality.</p>	[4]
	<ul style="list-style-type: none"> • Irrigation systems can supply water to dry soil and allow for the intensive cultivation of crops. It can also bring about negative impact on the soil and water quality. • Salinisation can occur as the pumping of groundwater to the irrigation channels can result in raising of the water table, which brings the salts closer to the surface at the upper soil layers as shown on Fig. 10. • As water evaporates from the soil, the salts are left behind which results in the soil becoming saline. This will then result in degradation of land as crops can no longer grow on the saline soil which has a high concentration of salts. • The salts from the groundwater can also enter the river as the water table is being raised from the tapping of groundwater which results in poorer water quality. 	
(e)	<p>"Physical factors play a great role in determining the levels of food production in LDCs."</p> <p>How far do you agree with this statement? Support your answer with evidence.</p>	[8]

(b)	<p>'Strategies introduced by countries have been more effective in managing climatic change than international agreements.'</p> <p>How far do you agree with this statement? Support your answer with examples.</p>	[8]		
	<p>Level 1 (0–3 marks) Answers are generalised or with minimal support if any given at all. Reasoning rather weak and expression may be unclear. A basic answer that has little development. Answers lack examples or other evidence or, it is sketchy that it adds little support to the answer.</p> <p>Level 2 (4–6 marks) Disagreement or agreement is supported by appropriate detail. Or, both agreement and disagreement are considered, but support is patchy so that the answer is not full. Good reasoning and logic in parts of the answer with good expression in places. Some examples or other evidence will be presented to support answers in at least one place in the answer.</p> <p>Level 3 (7–8 marks) Answers are comprehensive and supported by sound knowledge. Both agreement and disagreement are considered and well supported. Reasoning is clear and logical with good expression of language. Examples or other evidence to support answers are extensive. For L3 (8 marks), conclusion is well-explained and relative importance to be weighed to a criterion.</p>			
	<table border="1" style="width: 100%; border-collapse: collapse;"> <tr> <td style="width: 50%; padding: 5px;"> <p>Solutions by Countries</p> <p>Singapore</p> <ol style="list-style-type: none"> 1) Singapore Green Plan 2012 <ul style="list-style-type: none"> • Reduce energy consumption and greenhouse emission from burning fossil fuels 2) Green Mark Scheme <ul style="list-style-type: none"> • Constructing 'green' buildings 3) Plant-A-Tree programme <ul style="list-style-type: none"> • Planting more tree and plants </td> <td style="width: 50%; padding: 5px;"> <p>Solutions by International agreements</p> <p>Kyoto Protocol (1997)</p> <ul style="list-style-type: none"> • Kyoto Protocol: An international agreement to reduce greenhouse gases emission into the atmosphere. • Drawn up on 11/12/97, came into effect 16/02/05 • Different countries have different targets to hit and progress of carbon emissions will be tracked and reported for review. <p><u>Successes</u></p> <ul style="list-style-type: none"> • Many countries met or exceeded targets set by Kyoto Protocol as there was constant monitoring and reporting by countries for self and peer assessment. • Encouraged sustainable development. • Developed countries are encouraged to work with developing countries in carbon-reducing projects (Clean Development Mechanism — CDM) <p><u>Limitations</u></p> </td> </tr> </table>	<p>Solutions by Countries</p> <p>Singapore</p> <ol style="list-style-type: none"> 1) Singapore Green Plan 2012 <ul style="list-style-type: none"> • Reduce energy consumption and greenhouse emission from burning fossil fuels 2) Green Mark Scheme <ul style="list-style-type: none"> • Constructing 'green' buildings 3) Plant-A-Tree programme <ul style="list-style-type: none"> • Planting more tree and plants 	<p>Solutions by International agreements</p> <p>Kyoto Protocol (1997)</p> <ul style="list-style-type: none"> • Kyoto Protocol: An international agreement to reduce greenhouse gases emission into the atmosphere. • Drawn up on 11/12/97, came into effect 16/02/05 • Different countries have different targets to hit and progress of carbon emissions will be tracked and reported for review. <p><u>Successes</u></p> <ul style="list-style-type: none"> • Many countries met or exceeded targets set by Kyoto Protocol as there was constant monitoring and reporting by countries for self and peer assessment. • Encouraged sustainable development. • Developed countries are encouraged to work with developing countries in carbon-reducing projects (Clean Development Mechanism — CDM) <p><u>Limitations</u></p>	
<p>Solutions by Countries</p> <p>Singapore</p> <ol style="list-style-type: none"> 1) Singapore Green Plan 2012 <ul style="list-style-type: none"> • Reduce energy consumption and greenhouse emission from burning fossil fuels 2) Green Mark Scheme <ul style="list-style-type: none"> • Constructing 'green' buildings 3) Plant-A-Tree programme <ul style="list-style-type: none"> • Planting more tree and plants 	<p>Solutions by International agreements</p> <p>Kyoto Protocol (1997)</p> <ul style="list-style-type: none"> • Kyoto Protocol: An international agreement to reduce greenhouse gases emission into the atmosphere. • Drawn up on 11/12/97, came into effect 16/02/05 • Different countries have different targets to hit and progress of carbon emissions will be tracked and reported for review. <p><u>Successes</u></p> <ul style="list-style-type: none"> • Many countries met or exceeded targets set by Kyoto Protocol as there was constant monitoring and reporting by countries for self and peer assessment. • Encouraged sustainable development. • Developed countries are encouraged to work with developing countries in carbon-reducing projects (Clean Development Mechanism — CDM) <p><u>Limitations</u></p>			

	<ul style="list-style-type: none"> • It is determined by the rainfall and average temperature experienced in that place. • These factors can determine the types of crops that can be grown & productivity of land. • Generally, output is higher in areas with high temperature and rainfall as they are more favourable for plant growth. • Crops in the tropics can produce 2 or more successive crops in a year on the same field as the temperature and rainfall are high and constant throughout the year. • However, there are some exceptions like wheat and potatoes (require less water) thus they grow well in the temperate regions. • The type of climate is also an important factor for fish and livestock farming as they require different types of climates to grow well. For instance, salmon requires cool temperatures for growth and reproduction. <p>Other factors</p> <p>Economic factors</p> <p>Purpose of farming</p> <ul style="list-style-type: none"> • The tastes and preferences of consumers dictate what how much the producers grow. • <u>E.g.</u> China used to be self-sufficient in maize production and an exporter of maize as well. However in recent years due to the increased demand for meat and dairy products, more maize is needed to feed livestock. Therefore, with rising population, China has started importing maize to meet the increasing demand. USA has increased their production of maize to be exported to China. • Large food companies able to withstand the impact of changes in the environment, e.g. flooding, compared to small-scale farmers. • Agribusinesses are able to invest in technology to increase food production including research to produce crop with greater yield. • As they have a worldwide network of different farming, distribution and processing centres, they have greater control over crop production. Their production costs are reduced and hence the retail cost of food may be kept low. Example Dole – pineapple, bananas <p>Political factors</p> <p>Agricultural policy –pertaining to domestic agriculture</p> <ul style="list-style-type: none"> • Affects how limited resources such as money and land may best be used. <ul style="list-style-type: none"> -the govt. could direct financial resources towards educating farmers on more efficient farming methods. -helping farmers by <ul style="list-style-type: none"> --providing irrigation facilities --conducting agricultural research to develop higher-yielding or more resistant varieties of crops. - financial loans available to farmers and give subsidies for growing certain crops • In Oct 2011, ASEAN signed an agreement with China, Japan and South Korea. During times of disaster, rice reserves from the big rice producers will be used to supply rice to countries that have signed the agreement. • E.g. Thailand started a programme in 2012 for other ASEAN nations to intensify rice production in the region. Thailand worked with neighbouring countries such as Cambodia to increase their efficiency in rice production <p>Technological factors</p> <p>Green Revolution - [use of technology to increase food production]</p>	
--	--	--

Use of high-yielding varieties

- HYVs are improved strains of crops such as rice, wheat and other cereals that have an increased growth rate and an increased resistance against crop diseases and pests.
- "Wonder Rice" has a growing season of 100 days compared to the 120 days of non-HYVs.
- 70% of rice and wheat grown in India were HYVs by 1990.
- Green revolution helped to increase the production of wheat and rice in India.
- Total wheat production has almost multiplied 4 times that of 1970 by 2010
- Total rice production has multiplied by two times that of 1970 by 2010

Use of chemicals

- Chemical fertilisers replenish the nutrients in the soil and increase yield.
 - HYV requires more fertilizers - and helps to retain soil moisture.
 - Chemical fertilizers **provide specific quantities of a nutrient such as nitrogen potassium but are easily removed by water percolating through the soil.**
 - Pesticides used to kill insects **and small animals that destroy crops.**
 - Herbicides used to **kill weed and other undesirable plants that compete with for resources.**
 - With the removal of pests, the crop is protected which in turn would **increase crop yield.**
 - —

6 (a) Study Fig.11, which shows the Richter scale used to measure the magnitude of earthquakes and the death tolls of selected earthquakes.

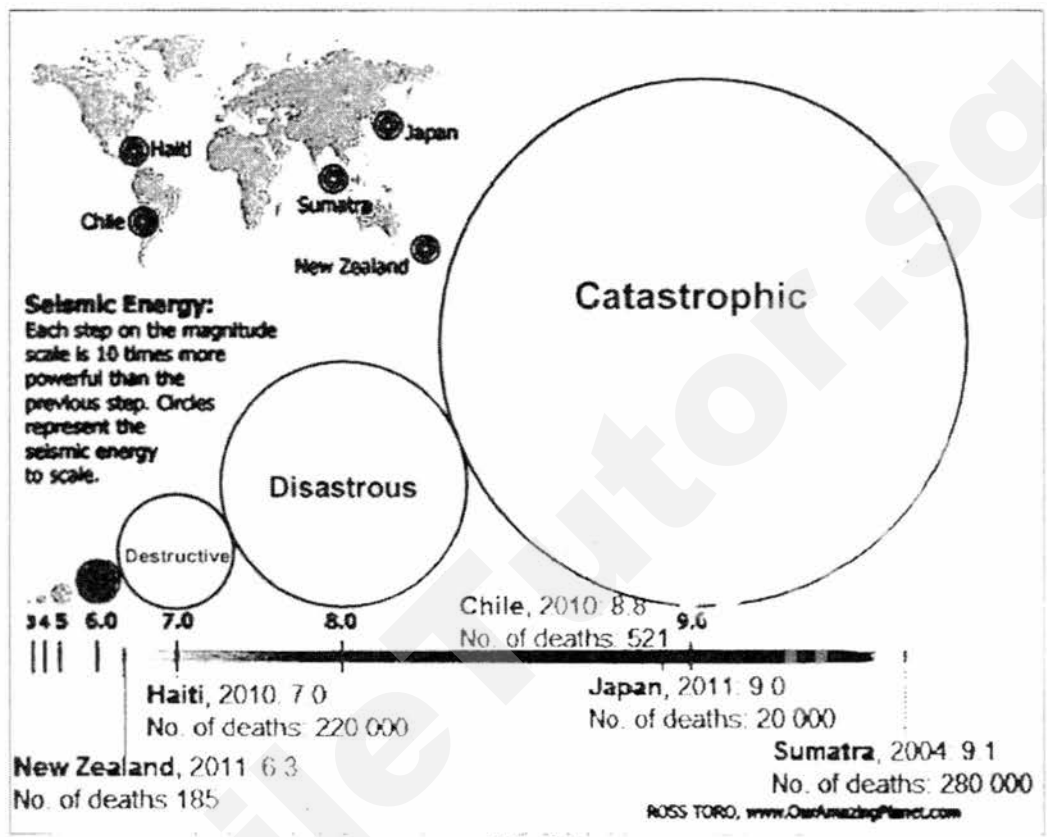
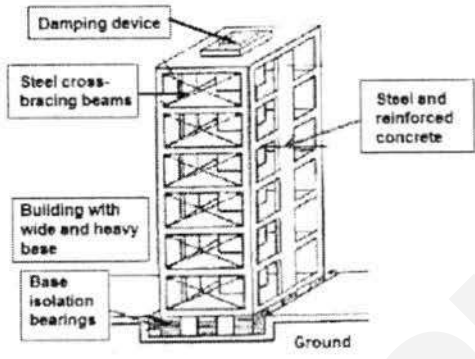

Fig. 11

Do higher magnitude earthquakes result in higher death tolls? Support your answer using information from Fig. 11.

[4]

- positive correlation/relationship between the magnitude of earthquake and the death toll.
- Supporting:**
- For example, the Sumatra earthquake was at a magnitude of 9.1 and resulted in 280000 deaths.
 - Similarly in New Zealand, there were only 185 casualties when the earthquake magnitude was 6.3.
- Non-supporting**
- However, there are cases when the magnitude does not correlate with the number of deaths. e.g Haiti experienced an earthquake of magnitude 7.0 with 220 000 deaths, but Chile with a higher magnitude earthquake of 8.8 recorded only 521 deaths. (May use example of Japan's 9.0 earthquake with 20 000 casualties).

(b)	Study Fig. 12 which shows an earthquake resistant building.	
	<p style="text-align: center;">Earthquake Resistant Building</p>  <p style="text-align: center;">Fig. 12</p>	
	Use Fig. 12 to account for the main features associated with an earthquake resistant building.	[4]
	<ul style="list-style-type: none"> • Damping device – act as shock absorbers for seismic energy released during earthquake and counterweights which move in opposite direction to the motion of the earthquake. • Steel and reinforced concrete – are used to withstand earthquakes better than brittle materials such as non-reinforced concrete. • Wide and heavy bases – decreases likelihood of building from collapsing. • Base isolation bearings – act as buffer to prevent the building from swaying too much during an earth quake. • Cross-bracing – reinforce walls using two steel beams to prevent building from collapsing easily. 	

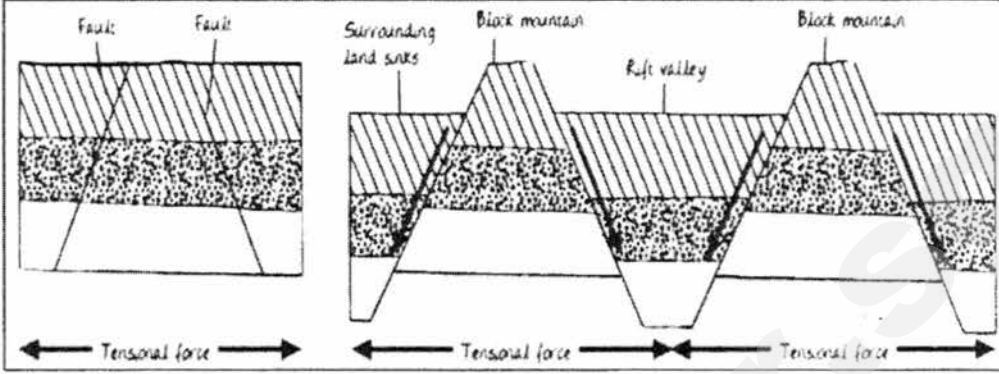
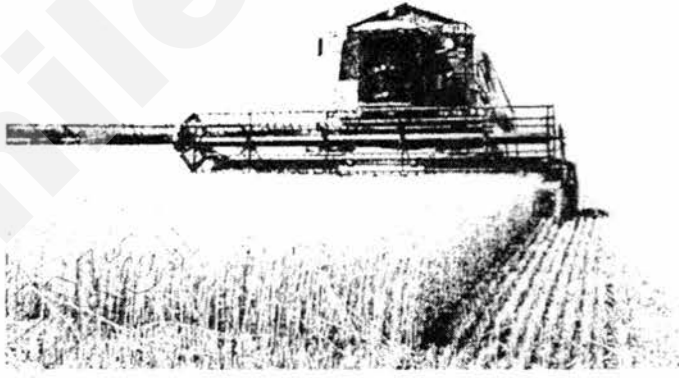
<p>(c)</p>	<p>With the aid of diagram(s), illustrate and explain the formation of block mountains. [5]</p>  <p>Award 2m for illustration (out of which 1m for labels and 1m for accuracy in drawing).</p> <p>Explanation:</p> <ul style="list-style-type: none"> • Block mountains are blocks of land with steep sides that are formed by continental-continental plate divergence. • They are formed when sections of the crust extend along fault lines and rock masses surrounding a central block sink due to tensional forces • The block of land that is left standing higher than the surrounding land is a block mountain.
<p>(d)</p>	<p>Study Photograph A, which shows a method of harvesting used by some farmers.</p>  <p style="text-align: center;">Photograph A</p>
	<p>With reference to Photograph A and other studies you have made, explain how technological advancements affect the intensity of food production. [4]</p>
	<ul style="list-style-type: none"> • Through the use of machinery such as a combined harvester, farming is more efficient as the process of harvesting is sped up and there is also less reliance on human labour. • High-yielding varieties (HYVs) are cross bred to develop improved strains of crops, e.g. shorter growing season which allows for more harvests a year, thus resulting in higher crop output.

	<ul style="list-style-type: none"> • Use of irrigation supplies water to land, e.g. use of centre pivot irrigation, thus allowing crops to be cultivated on land that used to be too dry, thus increasing amount of crops produced as there is more arable land available • Use of irrigation supplies water to land, e.g. use of centre pivot irrigation increases crop yield as crops can be grown all year round even when there is less rainfall/dry season. • Use of fertilisers helps to supply nutrients for healthy plant growth which in turn leads to higher crop output/yield OR replenish nutrients that have been used up which allows for shorter /no fallowing period, thus farmers are able to plant continuously, thus producing higher yield/output. <p><i>Other acceptable points include use of pesticide and HYVs</i></p>	
(e)	<p>'Food shortages are mainly the result of social factors.'</p> <p>To what extent is this statement true? Support your answer with evidence.</p>	[8]
	<div style="border: 1px solid black; padding: 5px;"> <p>Level 1 (0–3 marks) Answers are generalised or with minimal support if any given at all. Reasoning rather weak and expression may be unclear A basic answer that has little development. Answers lack examples or other evidence or, it is sketchy and it adds little support to the answer.</p> </div> <div style="border: 1px solid black; padding: 5px; margin-top: 5px;"> <p>Level 2 (4–6 marks) Disagreement or agreement is supported by appropriate detail. Or, both agreement and disagreement are considered, but support is patchy so that the answer is not full. Good reasoning and logic in parts of the answer with good expression in places. Some examples or other evidence will be presented to support answers in at least one place in the answer.</p> </div> <div style="border: 1px solid black; padding: 5px; margin-top: 5px;"> <p>Level 3 (7–8 marks) Answers are comprehensive and supported by sound knowledge. Both agreement and disagreement are considered and well-supported. Reasoning is clear and logical with good expression of language. Examples or other evidence to support answers are extensive. For L3 (8 marks), conclusion is well-explained and relative importance to be weighed to a criterion.</p> </div> <p>Possible answers Social factors (Given Factor) Food shortage may be caused by poor accessibility to food.</p> <ul style="list-style-type: none"> • Transport facilities such as road and rail links must be made available so that food can be reached even by people who live far away from shops. • The accessibility of food is also dependent on the number and location of food outlets. • Accessibility could be affected due to the physical factors such as mountains and the occurrence of landslides • Food distribution is particularly significant when the local production cannot meet local demand, making imports necessary • For example, in LDCs, food outlets may be few and far apart from one another. 	

	<ul style="list-style-type: none"> • As a result, people in these areas may be unable to obtain fresh produce and thus have a smaller food intake. • E.g. One-third of the population of Timor-Leste experiences food shortages in between food harvests • The chronic food shortage is made worse by a lack of storage facilities and the difficulty of accessing the numerous remote communities. • As such, poor accessibility to food could lead to food shortage <p>Alternative Factor: Political factors (Civil Strife)</p> <ul style="list-style-type: none"> • Food shortage may be caused by political factors such as civil strife, i.e. internal conflicts such as riots, unrest or civil war. • Civil strife may lead to disputes over the control of resources that affect food production, such as land and water. • These resources may even be destroyed which in turn hinders food production. • Landmines planted on farmlands during civil strife can destroy and stop food production • Poor governance such as corruption, policy errors and inability to implement policies can hinder food production and cause food shortages • Governments can also threaten food security when they prioritise other development needs of the country over ensuring food security (when people are able to obtain sufficient quantities of safe and nutritious food to maintain a healthy and active lifestyle) • An example of civil strife is, in 2011, civil strife in Syria disrupted agriculture and drastically reduced farmers' access to fertilisers and seeds. • An example of poor governance is, in the Indian state of Madhya Pradesh in 2010, 40 000 villagers were deprived of land for farming due to the development of a steel plant, mining and port. • As a result, these villagers lost the means to produce their own food and were left with extremely limited income to buy food. • All these factors caused food prices to rise, preventing many people from having access to food. <p>Economic factors</p> <ul style="list-style-type: none"> • The increase in food production may not be able to cope with the rapid increase in demand. • This is mainly caused by a rapidly growing urban middle class with higher purchasing power and changing food preferences. • The demand from these countries has the ability to redirect food from poorer countries because they are able to pay a higher price than the poorer countries. • For example, the sustained growth in demand for food from these countries (Brazil, Russia, India and China) is believed to be depleting global food inventories, especially grain. • When the demand for food outstrips supply, food shortage would ensue. <p>Physical/Environmental factors</p> <ul style="list-style-type: none"> • Changes in climate may cause existing farmland to become unsuitable for farming, while lengthening the growing season in other areas. • Climate change is likely to increase the occurrence of extreme weather events such as severe tropical cyclones and drought • As a result, crops may no longer be able to grow in some areas which were previously suitable for farming, thus causing shortage in food production 	
--	---	--

	<ul style="list-style-type: none">• Tropical cyclones could lead to flooding of farmland which could destroy the crops, causing a shortage in food production• Drought would also reduce water supply needed for crops to grow properly, thus increasing crop failure and reduce crop yield• For example, with global temperatures increase due to human activities, it is projected that countries across the world will see their current food production decrease by up to 50% and these include staple food producers such as Brazil, India, Pakistan, Turkey, parts of the USA, most of Southeast Asia and most of Australia.• In this manner, physical factors such as climate change and extreme weather events may lead to food shortage.	
--	--	--



BEDOK VIEW SECONDARY SCHOOL PRELIMINARY EXAMINATION 2017

CANDIDATE
NAME

REGISTER
NUMBER

CLASS

GEOGRAPHY
Secondary Four Express
Paper 1

2236/01

18 August 2017

1 hour 40 minutes

Additional Materials: Answer Paper
1 Graph Paper

1:25 000 Map Extract is enclosed with this Question Paper.

READ THESE INSTRUCTIONS FIRST

Write your index number and name on all the work you hand in.
Write in dark blue or black pen on both sides of the paper.
You may use a HB pencil for any diagrams or graphs.
Do not use staples, paper clips, glue or correction fluid.

Section A

Answer Question 1.

Section B

Answer **one** question.

Write all answers on the Answer Paper provided.
Candidates are encouraged to support their answers with the use of relevant examples.
Sketch maps and diagrams should be drawn whenever they serve to illustrate an answer.

At the end of the examination, fasten all your work securely together.
The number of marks is given in brackets [] at the end of each question or part question.

For Examiner's use		
Section A		/ 25
Section B		/ 25
Total		/ 50
% / Grade		/

Setter: Miss Hafizah

Parent's / Guardian's Signature:

This document consists of 11 printed pages and 1 blank page.

Do not turn over the page until you are told to do so.

Section A

This question is compulsory.

- 1 A group of students went on a fieldwork to Langkawi which is an island located in Malaysia. Langkawi is a coastal area famous for its luxury coastal resorts and it had recently set up Langkawi International Convention Centre. The students wanted to conduct a coastal and tourism fieldwork at the place at Site 1, Site 2 and Site 3. Photograph A shows a satellite image of Langkawi Island.

Satellite image of Langkawi Island

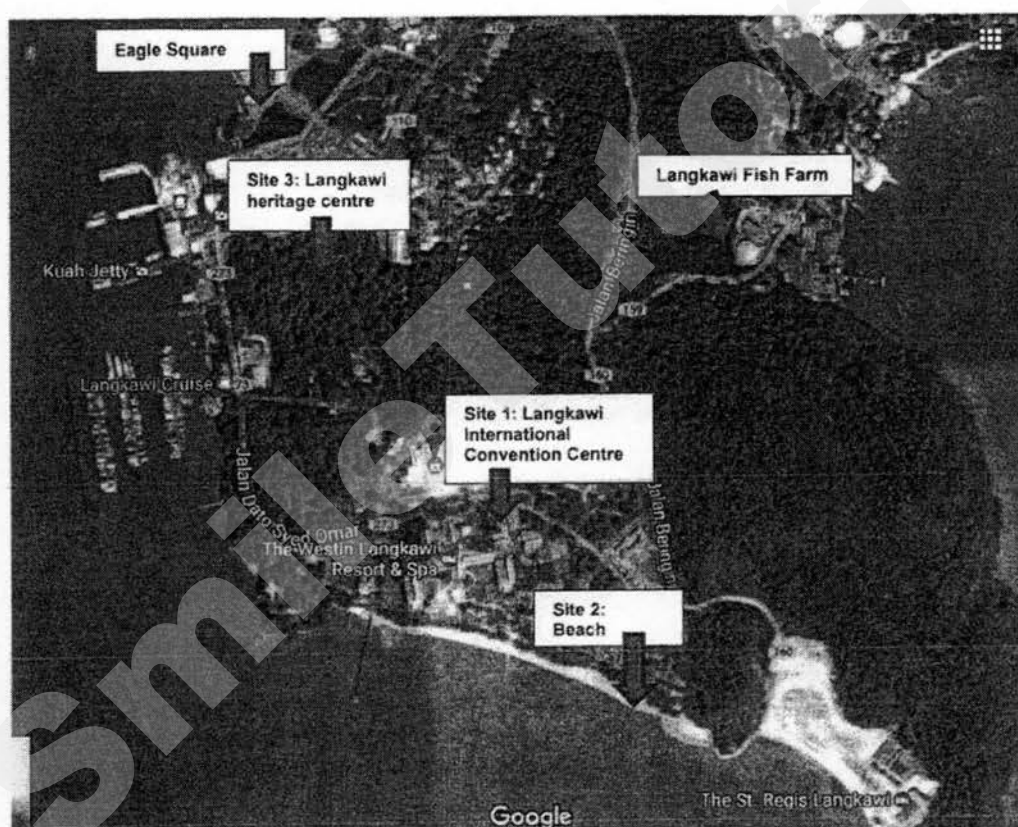

Photograph A

Source: Google Map

The students would like to find out more about Meetings, Incentives, Conventions and Exhibitions (MICE) tourism and the different types of attractions in Langkawi.

The students decided to craft a hypothesis for their field investigation on MICE tourism in Langkawi. They decided on the following hypothesis :

MICE tourism is the most popular type of tourism amongst tourists who visit Langkawi.

To test this hypothesis, the students planned to conduct a questionnaire survey on one weekday afternoon. They positioned themselves at **Site 1** (outside the Convention Centre), **Site 2** (the beach) and **Site 3** (Langkawi heritage centre) as shown in Photograph A.

At each site, the students planned to interview 20 tourists using a random sampling method to find out the tourists' views about Langkawi's attractions for MICE and leisure tourism.

- (a) Comment on the choice to interview the tourists at the 3 sites and describe the advantages of adopting the sampling method. [4]
- (b) Study Fig. 1 which shows a visitor questionnaire designed by the students. This questionnaire is used by the students at all the 3 sites.

VISITOR QUESTIONNAIRE	
Dear Visitor, We are doing a survey as part of our Geography fieldwork and we would like to find the most popular type of activity in Langkawi. Your response will help us greatly in our investigation. The survey will only take 5 minutes. Thank you!	
Date	_____ March 2017
Gender	<input type="checkbox"/> Male <input type="checkbox"/> Female
Income per month	<input type="checkbox"/> Less than \$2000 <input type="checkbox"/> \$2000-\$4000 <input type="checkbox"/> \$4000-\$6000 <input type="checkbox"/> \$6000-\$8000
Which region are you from?	<input type="checkbox"/> Asia <input type="checkbox"/> Middle East <input type="checkbox"/> Europe <input type="checkbox"/> Others <input type="checkbox"/> America
How many times have you been to Langkawi?	<input type="checkbox"/> 1 st time <input type="checkbox"/> 4th time <input type="checkbox"/> 2 nd time <input type="checkbox"/> More than 4 times <input type="checkbox"/> 3 rd time
Where do you visit in Langkawi?	<input type="checkbox"/> Sightseeing attractions (i.e. Eagle Square) <input type="checkbox"/> Langkawi Heritage centre <input type="checkbox"/> Langkawi Fish farms <input type="checkbox"/> Beaches <input type="checkbox"/> Langkawi International Convention Centre <input type="checkbox"/> Others: _____
Why do you visit these places?	_____ _____

Fig. 1

Assess the design of the questionnaire survey as shown in Fig. 1. [3]

- (c) After conducting the questionnaire survey, the students tabulated the following data in Table 1.

Nature of Travel	Number of tourists
MICE	12
Heritage tourism	15
Honeypot	33
Total number of tourists = 60	

Table 1

Justify the conclusion that can be drawn from the information in Table 1 in response to the hypothesis tested and evaluate the reliability of the findings. [4]

- (d) Besides using a questionnaire survey, describe another data collection method that the students can use to determine the popularity of tourism in Langkawi at the 3 sites. [4]
- (e) Some of the personal information in the questionnaire in Fig. 1 have not yet been used by the students in their fieldwork investigation.

Suggest a hypothesis for an investigation that the students could carry out linking the personal information to places of visit in Langkawi. [1]

- (f) The students were also keen to find out about coastal processes at **Site 2** (the beach) in Photograph A. The group marked out a line of transect from points A to E as shown in Photograph B.

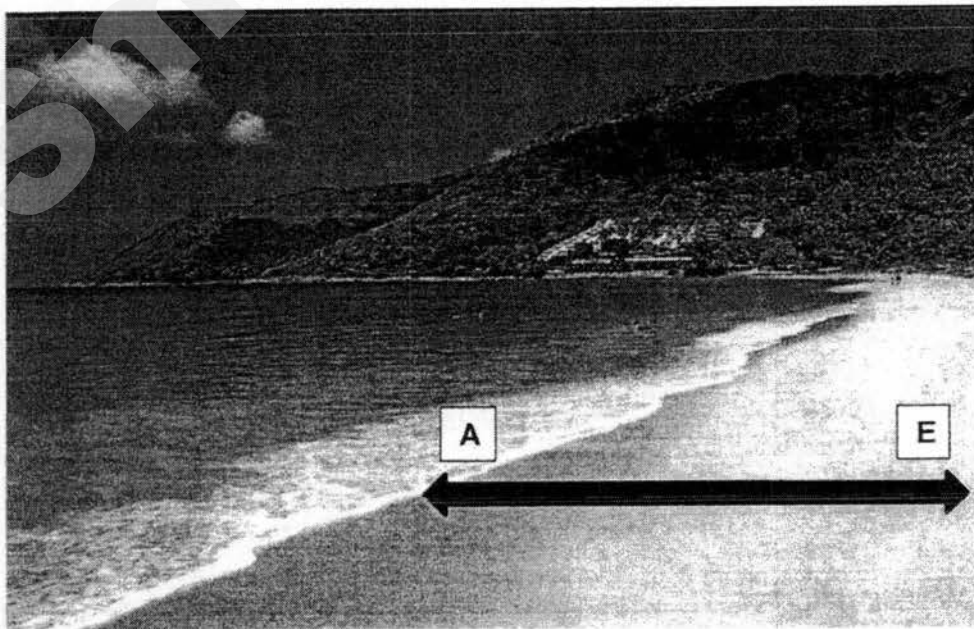

Photograph B

Source: <https://www.tripadvisor.com/TravelersChoice-Beaches-cTop-g2>

The students wanted to find out about the type of waves and the size of sediments that are found along the line of transect marked A to E on Photograph B.

The students collected samples of sediments along the transect A to E at a regular interval of 5 m. They measured the sediments collected at each point and compiled the data as shown in Table 2 below.

Distance along transect	A (0m)	B (5m)	C (10m)	D (15m)	E (20m)
Width of sediments in millimetres	13.4	11.1	10.9	14.2	9.0

Table 2

- Describe how the results in Table 2 are collected. [3]
- (g) Discuss how the students can determine the types of waves along the transect A to E. [2]
- (h) With reference to Table 2, draw a scatter graph on the graph paper provided to represent the data and suggest a reason for the anomaly reading. [4]

6

Section B

Answer **one** question from this section.

- 2(a) Explain how geology of rocks and types of waves affect the rate of coastal erosion. [4]
- (b) Study Fig. 2 which shows the process of wave refraction as it approaches the coast.

Wave refraction along the coast

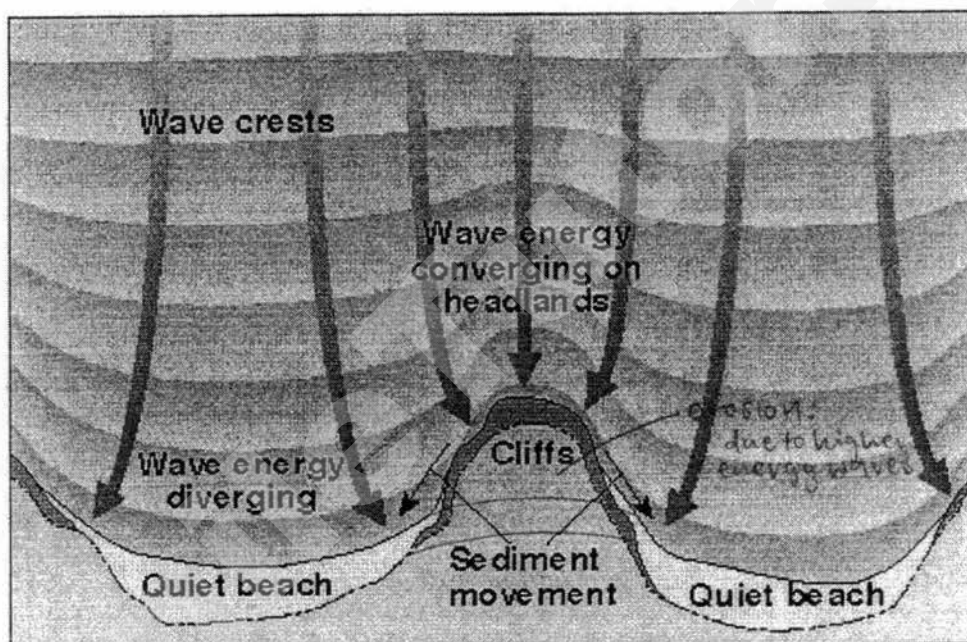

Fig. 2

Source: <http://www.mta.ca/~raiken/Courses/3361/3361-Coastal/Lectures/Lecture%20Summaries/Waves/waveref3.jpg>

Use Fig. 2 to predict how wave refraction may change the coastline. [4]

7

- (c) Fig. 3A shows the distribution of endangered coral reefs in the world. Fig. 3B shows a street map of Coral Bay, which is a popular snorkelling site.

Distribution of endangered coral reefs in the world

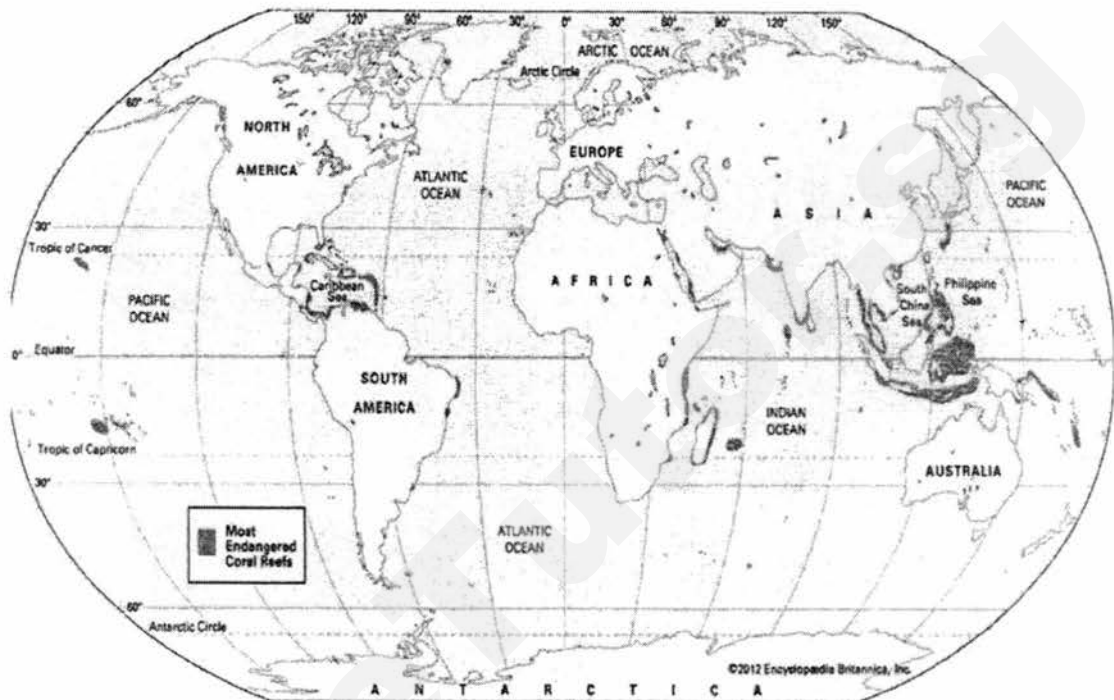

Fig. 3A

Source: <http://media1.britannica.com/eb-media/77/162777-004-874B2E46.gif>

Street map of Coral Bay

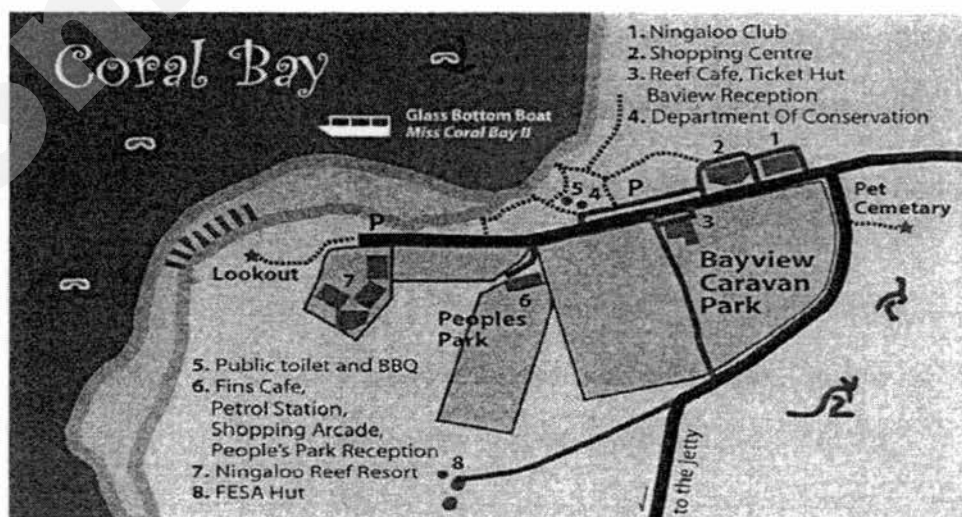

Fig. 3B

Source: http://www.ningaloo coast.com/yahoo_site_admin/assets/images/coralbag-mudmap-big.98124324_std.jpg

With reference to Fig. 3A and 3B, describe the distribution of endangered coral reefs in the world and explain why they are under threat? Visit smiletutor.com for more information.

- (d) Study Fig. 4 which shows a type of coastal protection measure.

Coastal protection measure

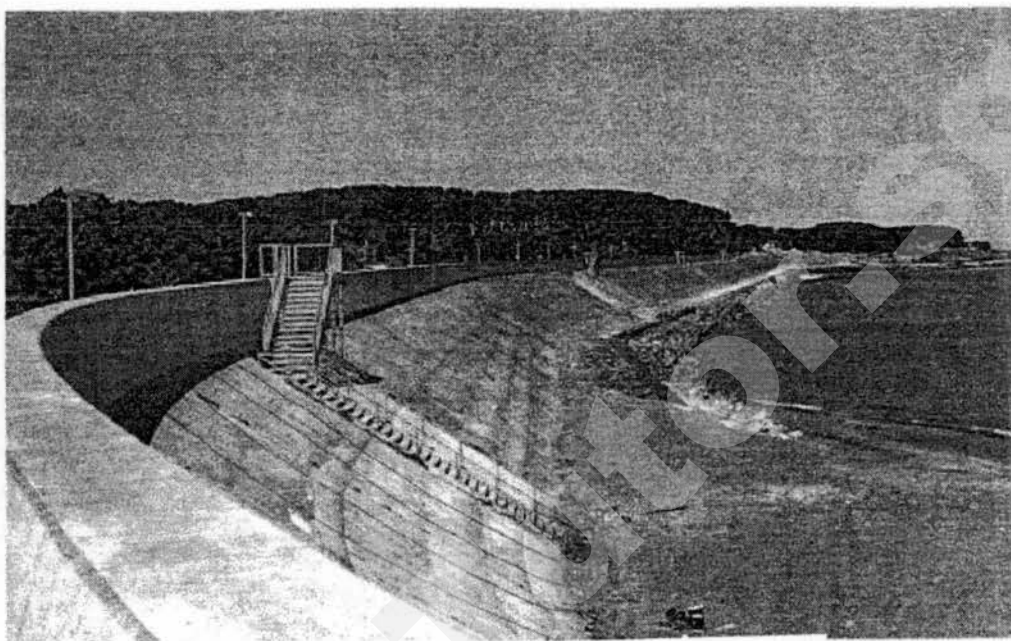

Fig. 4

Source: <http://gazettereview.com/wp-content/uploads/2015/03/.jpg>

Describe the type of coastal protection measure in Fig. 4 and assess its effectiveness in reducing the rate of coastal erosion.

[4]

- (e) 'Coastal deposition is responsible for major coastal landforms.'

To what extent is this statement true?

Support your answer with examples.

[8]

3(a) Study Fig. 5 which shows a sketch map of a cliff along a coastline.

Sketch map of a cliff along a coastline

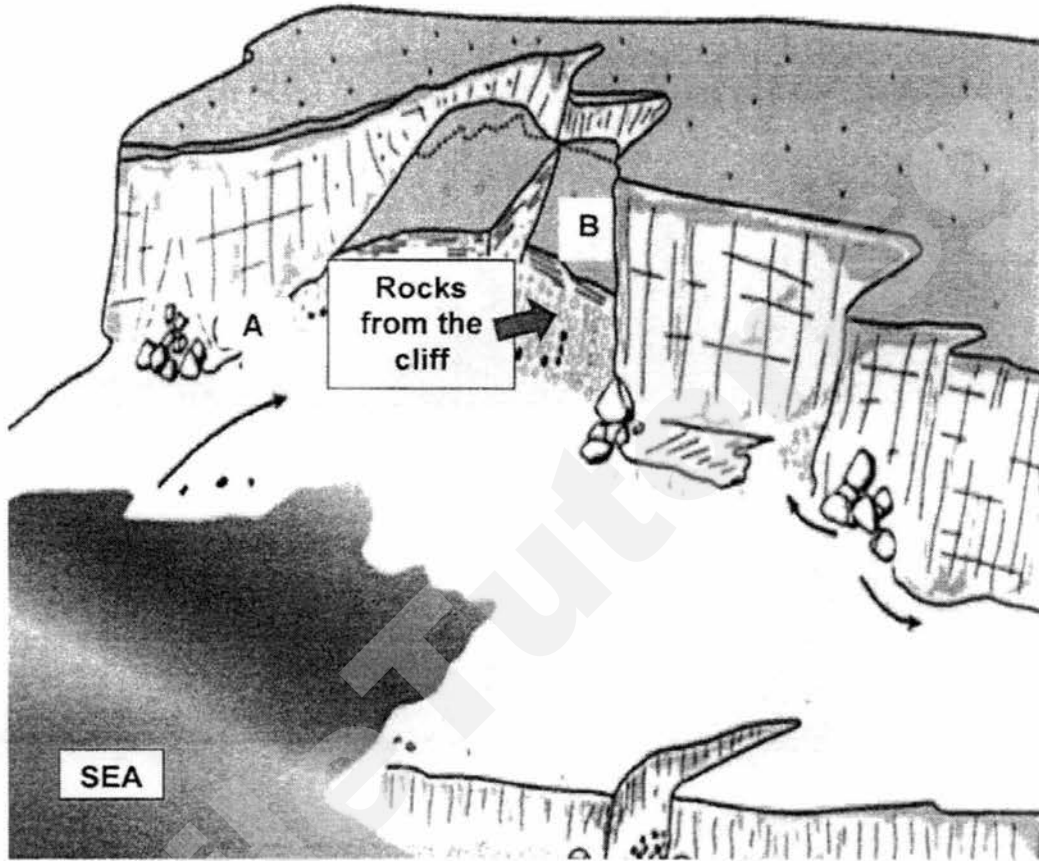

Fig. 5

Source: <http://sedres.geoscienceworld.org/content/82/4/260/F9.large.jpg>

Using Fig. 5, explain how erosional processes at A and B can form coastal landforms.

[4]

- (b) Study Fig. 6 which shows a cross section of the changing beach profile before and after a storm.

Cross section of the changing beach profile

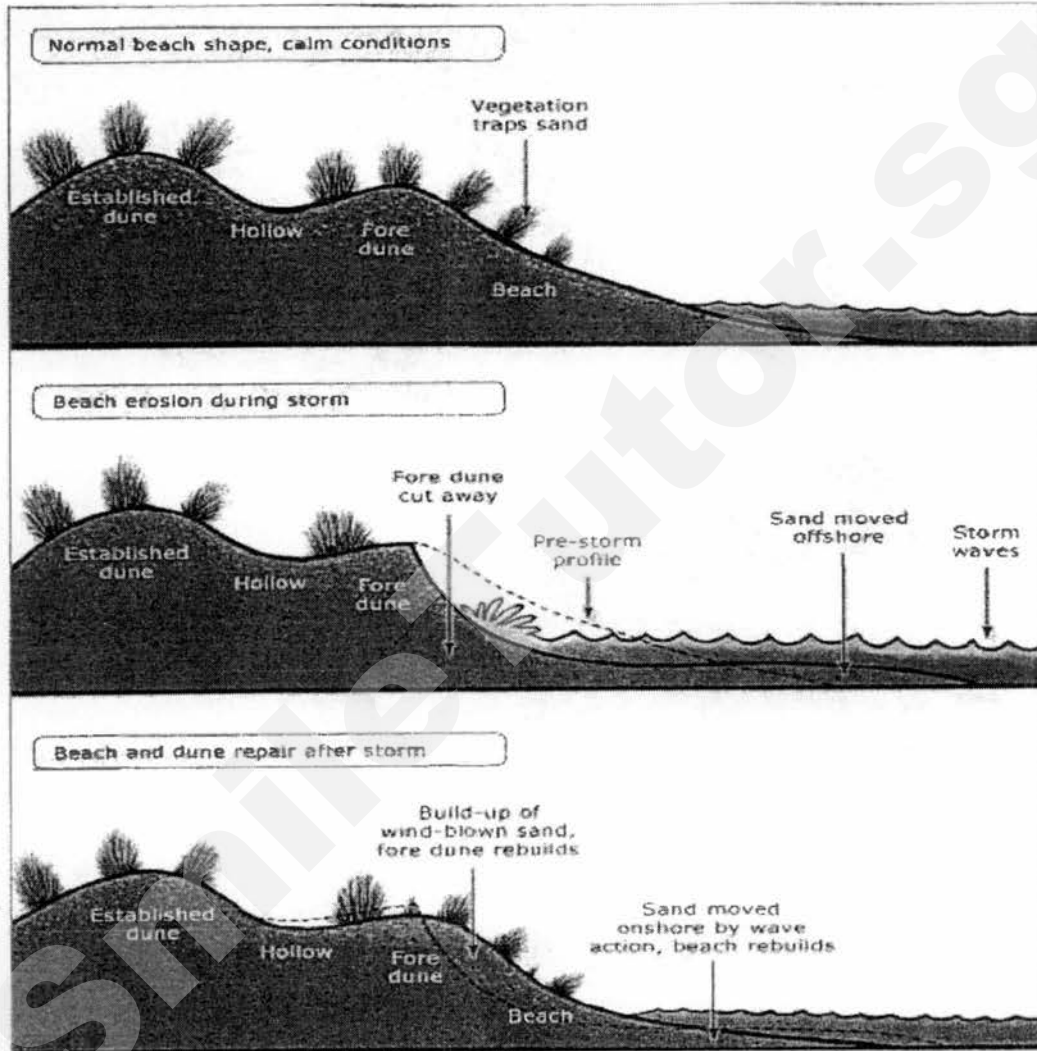

Fig. 6

Source: <https://s3.amazonaws.com/gs-geo-images/0e18e82a-ab7b-4f1d-aa8e-ef2cd1d8a379.jpg>

With reference to Fig. 6, show how the beach profile has evolved and outline how the beach materials are transported to rebuild the beach.

[5]

- (c) Study the topographical map extract of Mauritius. The scale is 1:25 000 and contours are shown in 10m intervals.

The location between Eastings 26 and 29 and Northings 94 and 98 is a major tourist area.

With reference to the topographical map, explain why people are attracted to the area.

[4]

- (d) With the aid of examples, assess the socio-cultural impact of tourism.

[4]

- (e) 'Affordable transportation is the main influence for the growth of global tourism.'

How far do you agree with this statement?

Support your answer using examples.

[8]

-End of paper-



BEDOK VIEW SECONDARY SCHOOL PRELIMINARY EXAMINATION 2017

CANDIDATE
NAME

REGISTER
NUMBER

CLASS

GEOGRAPHY
Secondary Four Express
Paper 2

2236/02
21 August 2017
1 hour 30 minutes

Additional Materials: Answer Paper

READ THESE INSTRUCTIONS FIRST

Write your index number and name on all the work you hand in.
Write in dark blue or black pen on both sides of the paper.
You may use a HB pencil for any diagrams or graphs.
Do not use staples, paper clips, glue or correction fluid.

Section A

Answer **one** question.

Section B

Answer **one** question.

Write all answers on the Answer Paper provided.
Candidates are encouraged to support their answers with the use of relevant examples.
Sketch maps and diagrams should be drawn whenever they serve to illustrate an answer.

At the end of the examination, fasten all your work securely together.
The number of marks is given in brackets [] at the end of each question or part question.

For Examiner's use		
Section A		/ 25
Section B		/ 25
Total		/ 50
% / Grade		/

Setter: Miss Hafizah

Parent's / Guardian's Signature:

This document consists of 11 printed pages and 1 blank page.

Do not turn over the page until you are told to do so.

Need a home tutor? Visit smiletutor.sg

2

Section A

Answer **one** question from this section.

- 1(a) Study Figs. 1A and 1B. Fig 1A shows the elevation map of Australia and Fig. 1B describes the relationship between air pressure and altitude.

Elevation map of Australia

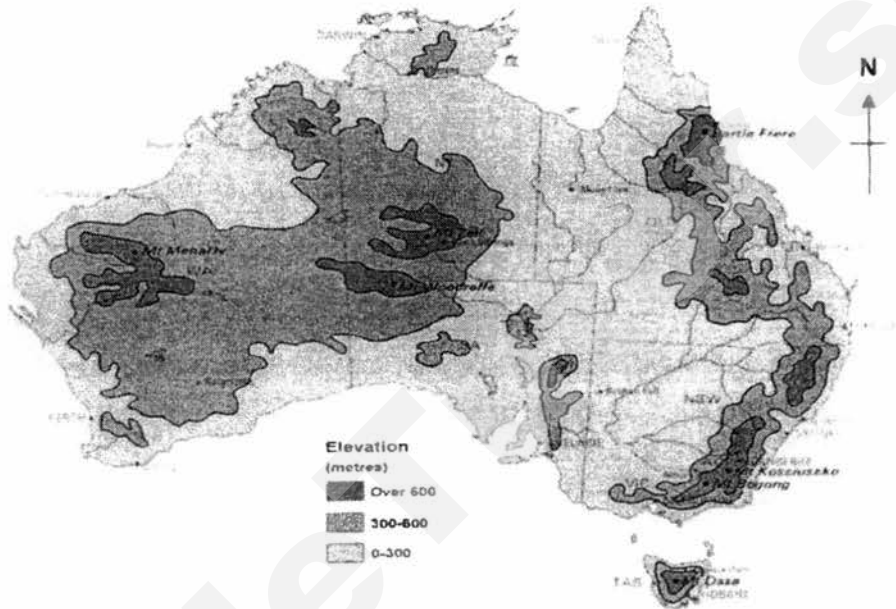

Fig. 1A

Source: <http://www.about-australia.com/geographic-features/>

Relationship between altitude and pressure

Altitude in meters	Pressure in millibars
0	1013.2
152	994.8
305	977.3
457	959.4
610	942.1

Fig. 1B

Source: https://www.edcousa.net/images/altitude_chart.png

With reference to Fig. 1A and 1B, describe the elevation in Australia and account for the difference in pressure at different locations. [5]

- (b) Fig. 2 shows a regional wind system that brings rain to Central Asia.

Regional wind system in Central Asia

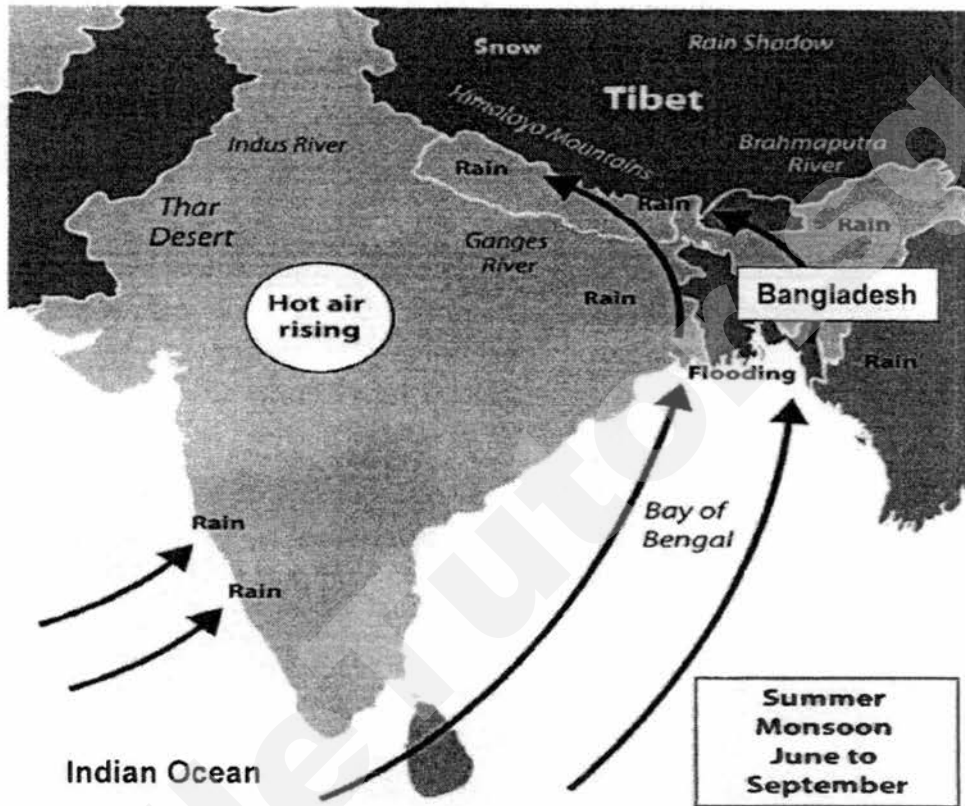

Fig. 2

Source: https://saylordotorg.github.io/text_world-regional-geography-people-places-and-globalization/section_12/0280af41915b1e636d329a04b52d6b32.jpg

- Using Fig. 2, explain the occurrence of floods at Bangladesh. [4]
- (c) With the use of examples, comment on the effectiveness of responses to climate change at the national level. [4]

4

- (d) Study Fig. 3 which shows an infographic of human activities on the environment.

Human activities on the environment

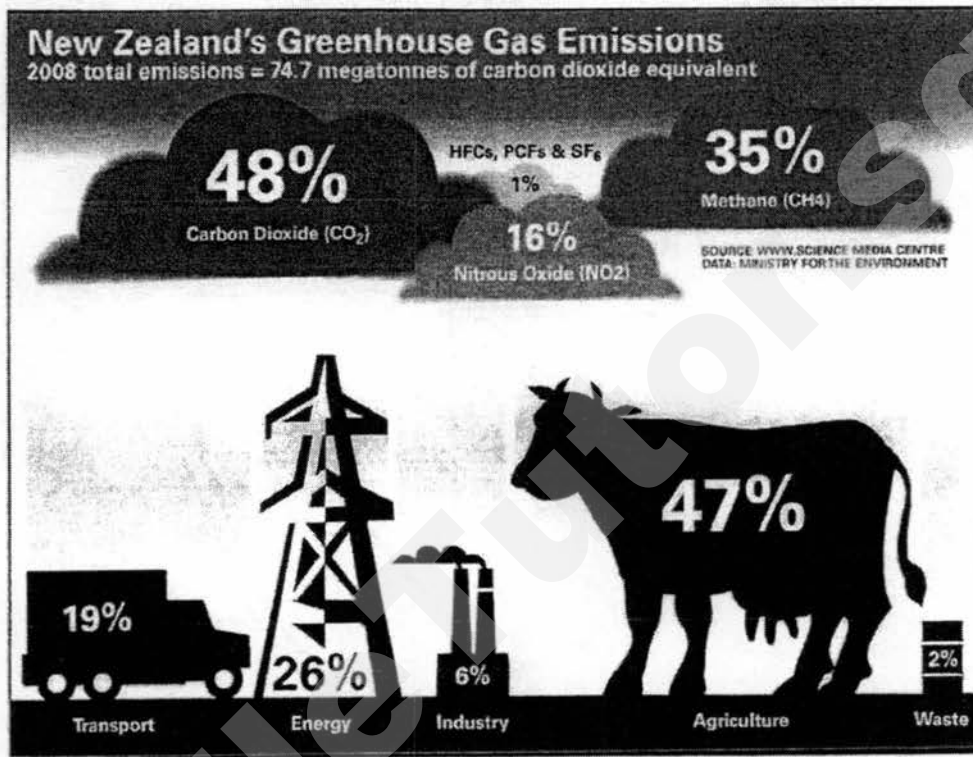

Fig. 3

Source:

http://www.fao.org/economic/ess/environment/ghg2014/en/?referrer=yahoo&category=beauty_food&include_utm=1

Using Fig. 3, explain how human activities contribute to the increase in global temperature. [4]

- (e) 'The differential rate of heating of land and sea is responsible for the variation in temperature at different locations.'

Discuss the accuracy of the statement.

Use examples to support your answer. [8]

- 2(a) Study Figs. 4A and 4B on Cyclone Sandy which hit United States of America in 2012.

Satellite image of Cyclone Sandy

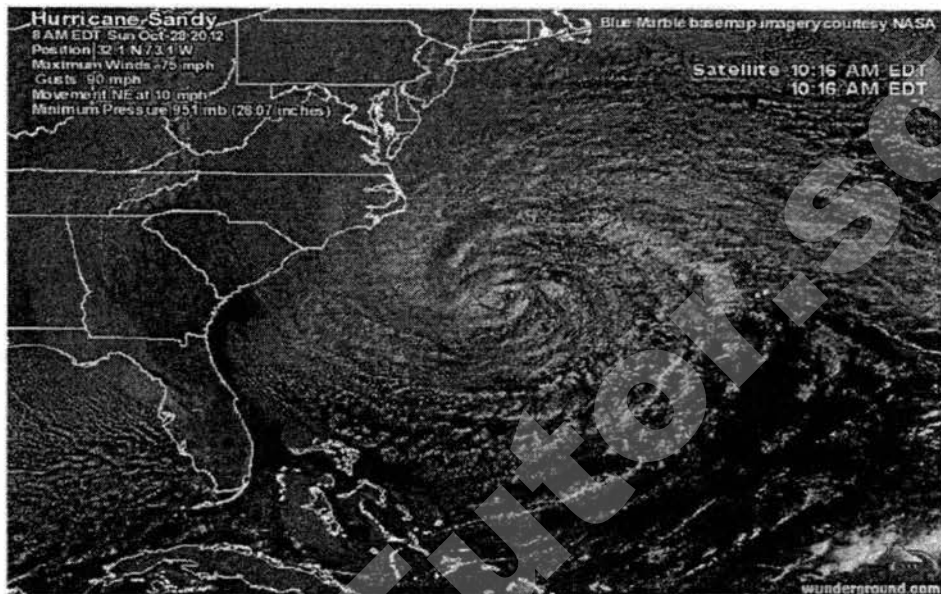

Fig. 4A

Source: http://icons.wxug.com/hurricane/2012/oct29_sat.jpg

Path taken by Cyclone Sandy

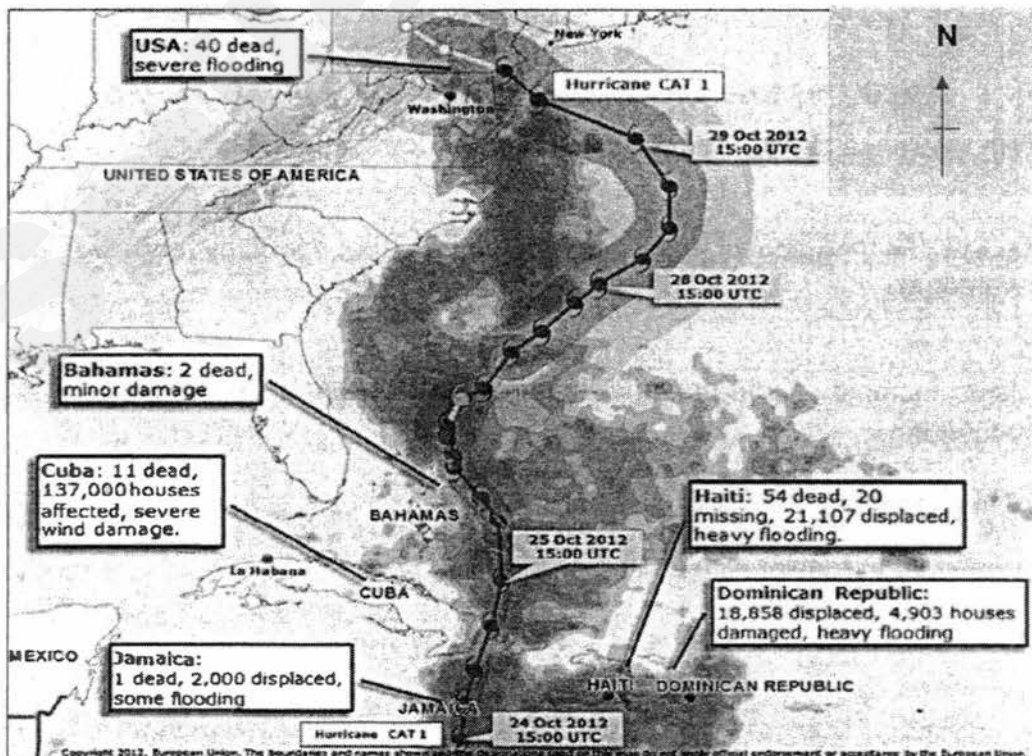

Fig. 4B

Source: <http://reliefweb.int/sites/reliefweb.int/files/resources/sandymap.pdf>

6

- (i) Using Fig. 4A and your own studies, describe the characteristics of Cyclone Sandy and outline the factors affecting its strength and spinning direction. [4]
- (ii) Using Fig. 4B, describe the path taken by Cyclone Sandy and discuss its damage. [5]
- (b) Fig. 5 shows a formation of tsunami.

Formation of a tsunami

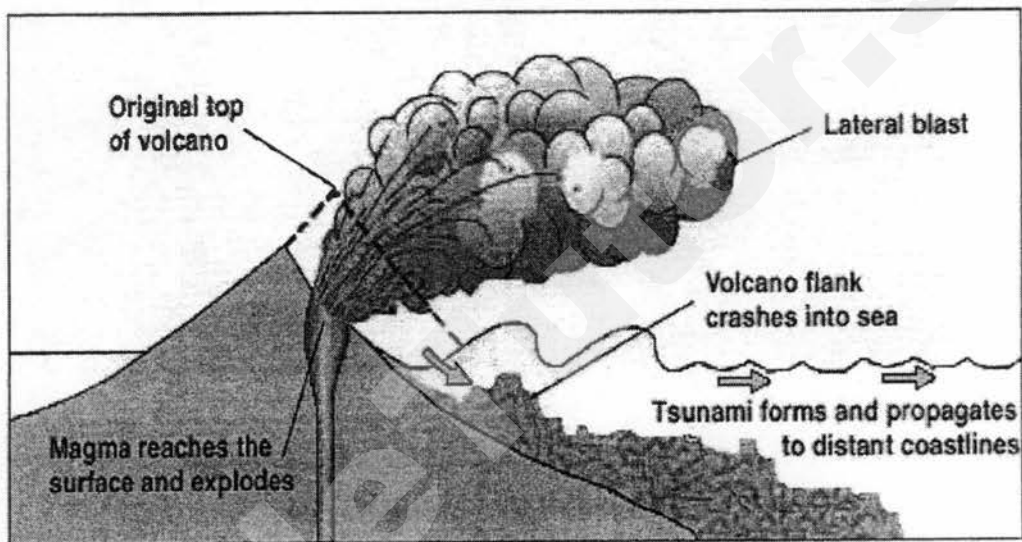

Fig. 5

Source: http://www.pdhone.com/courses/g207/g207content_files/image021.jpg

- With reference to Fig. 5 only, account for the formation of tsunami. [4]
- (c) Assess the impacts of volcanic eruption on the economy and the local community. [4]
- (d) 'Major tectonic landforms and features are formed at convergent plate boundaries.'
- To what extent is the statement true?
- Support your answer with examples. [8]

Section B

Answer one question from this section.

- 3(a) Study Fig. 6 which shows the calories consumed per capita per day in China and India from 1980 to 2013.

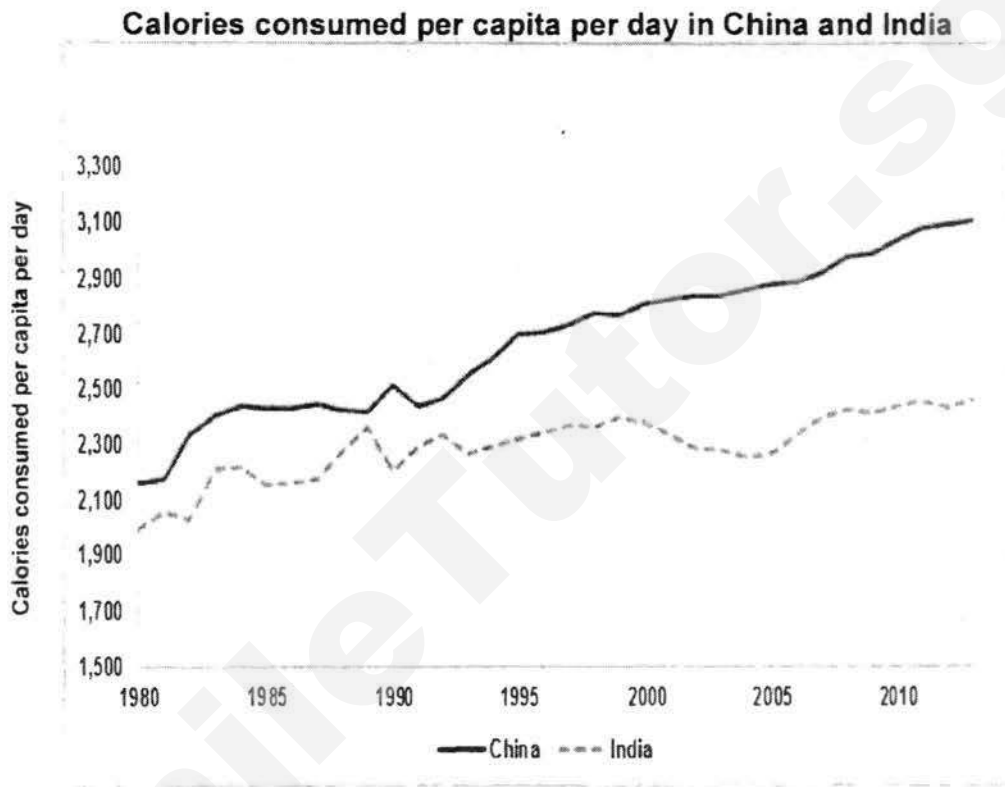

Fig. 6

Source: http://farmdocdaily.illinois.edu/2015/07/02/fdd07022015_fig3.jpg

Using Fig. 6, compare the changes in the calories between China and India from 1980 to 2013 and discuss the effects of malnutrition on developing countries.

[5]

- (b) Study Fig. 7 which shows the dominant soil stresses in the world.

Dominant soil stresses

Dominant soil stress	Global land area	
	Million km ²	% of total
Continuous moisture stress	36.5	27.9
Continuous low temperatures	21.8	16.7
Seasonal moisture stress	10.3	7.9
Low nutrient-holding capacity	7.8	6.0
Shallow soils	7.4	5.6
Excessive nutrient leaching	4.5	3.4
High aluminum	4.1	3.1
Low moisture and nutrient status	3.5	2.7
Low water-holding capacity	3.4	2.6
Other stresses	27.2	20.8
Few constraints	4.1	3.1
Total	130.6	100.0

Source: Eswaran et al. (various years).

Fig. 7

Source:

http://manoa.hawaii.edu/durp/files/2016/10/2014_Spring_Building_Resilient_Food_System.compressed.pdf

Using Fig. 7, explain how poor soil fertility and drainage can affect food production. [2]

- (c) Study Fig. 8 which shows an infographic of modern developments in farming.

Modern developments in farming

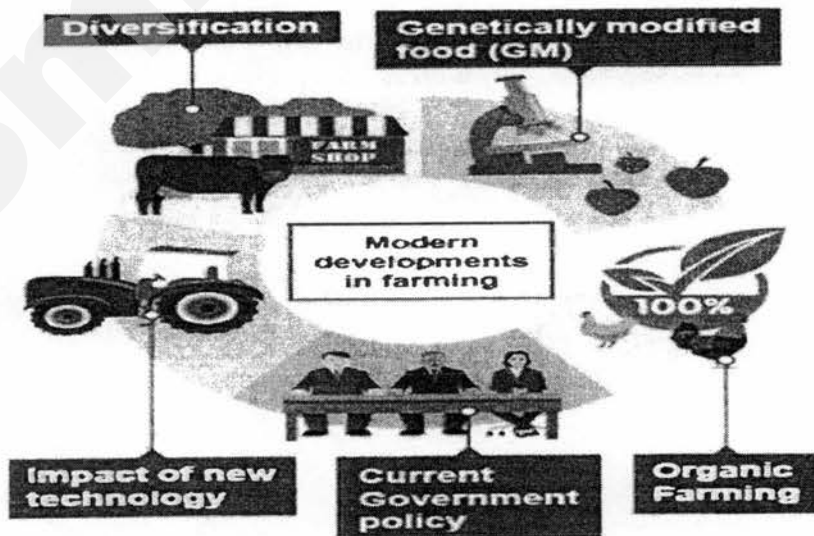

Fig. 8

Source: <https://bam.files.bbci.co.uk/bam/live/content/z79gkqt/small>

Using Fig. 8, show how modern developments in farming can boost food security. [5]

(d) Using an example, discuss the successes and limitations of genetically modified food in tackling the issue of food shortage. [5]

(e) 'The variation in food consumption patterns in different countries is mainly due to economic reasons.'

How far do you agree with this statement?

Support your answer using examples. [8]

SmileTutor.sg

- 4(a) Study Fig. 9 which shows the consumption of meat and fish in Europe.

Consumption of meat and fish in Europe

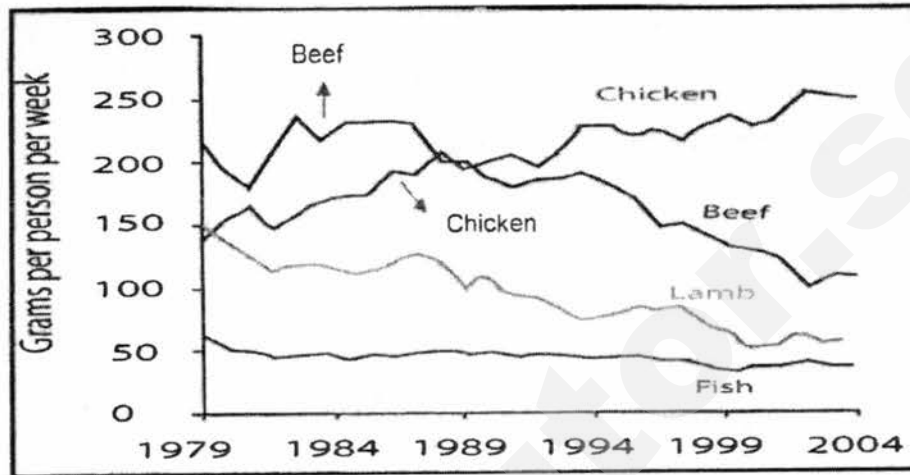

Fig. 9

Source: http://www.testbig.com/sites/default/files/Fish_and_meat_consumption.jpg

Using Fig. 9, compare the trends of chicken and beef between 1979 and 2004 and account for its patterns.

[5]

- (b) Study Fig. 10 which shows the supply chain of a local food hub.

Supply chain of a local food hub



Fig. 10

Source: <http://3rqwhc1s0oq36ghi9103i28l.wpengine.netdna-cdn.com/wp-content/themes/local-food-hub-theme/images/how-it-works-graphic.png>

With reference to Fig. 10 and your own studies, explain how food security can be improved in a local community.

[4]

Need a home tutor? Visit smiletutor.sg

- (c) Study Fig. 11 which shows the global spread of Zika virus.

Global spread of Zika virus

Zika across the world

Dates first detected

(Data published in Brazilian research journal Pesquisa FAPESP)

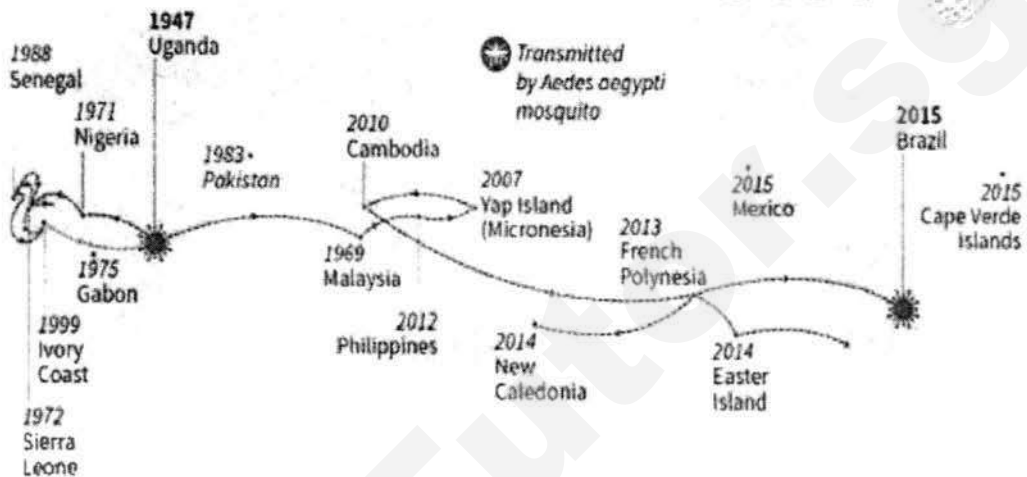

Fig. 11

Source: <https://pbs.twimg.com/media/CaHQFfrVAAAQ8Au.jpg>

With reference to Fig. 11 and your own studies, show how relocation diffusion causes the spread of the Zika virus and account for its spread. [3]

- (d) Using examples, evaluate the role of individuals and international organisations in managing the spread of diseases. [5]

- (e) 'Investment and access to healthcare plays the most important role in determining the health levels of a country.'

Discuss the accuracy of this statement.

Support your answer with examples. [8]

-End of paper-

SmileTutor.sg

BEDOK VIEW SECONDARY SCHOOL
PRELIMINARY EXAMINATION 2017 Answers

Section A

This question is compulsory.

- 1 A group of students went on a fieldwork to Langkawi which is an island located in Malaysia. Langkawi is a coastal area famous for its luxury coastal resorts and it had recently set up Langkawi International Convention Centre. The students wanted to conduct a coastal and tourism fieldwork at the place at Site 1, Site 2 and Site 3. Photograph A shows a satellite image of Langkawi Island.

The students would like to find out more about Meetings, Incentives, Conventions and Exhibitions (MICE) tourism and the different types of attractions in Langkawi.

The students decided to craft a hypothesis for their field investigation on MICE tourism in Langkawi. They decided on the following hypothesis :

MICE tourism is the most popular type of tourism amongst tourists who visit Langkawi.

To test this hypothesis, the students planned to conduct a questionnaire survey on one weekday afternoon. They positioned themselves at Site 1 (outside the Convention Centre), Site 2 (the beach) and Site 3 (Langkawi heritage centre) as shown in Photograph A. The investigation all the 3 sites are carried out concurrently at the same time.

At each site, the students planned to interview 20 tourists using random sampling method to find out the tourists' views about Langkawi's attractions for MICE and leisure tourism.

- (a) Comment on the choice to interview the tourists at the 3 sites and describe the advantages of adopting the sampling method. [4]

Award 2 marks for comment.

Award 2 marks for describe.

Comment:

- Interviewing the tourists at the 3 different sites allows for comparison of results at each site.
- However, there are 2 other sites i.e. Langkawi Fish Farm and Eagle Square, which are omitted from the fieldwork and this may affect the responses.

Describe:

- Random sampling method requires no regular or specific pattern and hence may be more convenient in carrying out the interview.
- Random sampling is the least biased of all sampling techniques as there is no subjectivity.
- Each member of the total population has an equal chance of being selected.

- (b) Study Fig. 1 which shows a visitor questionnaire designed by the students. This questionnaire is used by the students at all the 3 sites.

VISITOR QUESTIONNAIRE	
Dear Visitor, We are doing a survey as part of our Geography fieldwork and we would like to find the most popular type of activity in Langkawi. Your response will help us greatly in our investigation. The survey will only take 5 minutes. Thank you!	
Date	_____ March 2017
Gender	<input type="checkbox"/> Male <input type="checkbox"/> Female
Income per month	<input type="checkbox"/> Less than \$2000 <input type="checkbox"/> \$2000-\$4000 <input type="checkbox"/> \$4000-\$6000 <input type="checkbox"/> \$6000-\$8000
Which region are you from?	<input type="checkbox"/> Asia <input type="checkbox"/> Middle East <input type="checkbox"/> Europe <input type="checkbox"/> Others <input type="checkbox"/> America

How many times have you been to Langkawi?	<input type="checkbox"/> 1 st time <input type="checkbox"/> 2 nd time <input type="checkbox"/> 3 rd time <input type="checkbox"/> 4 th time <input type="checkbox"/> More than 4 times
Where do you visit in Langkawi?	<input type="checkbox"/> Sightseeing attractions (i.e. Eagle Square) <input type="checkbox"/> Langkawi Heritage centre <input type="checkbox"/> Langkawi Fish farms <input type="checkbox"/> Beaches <input type="checkbox"/> Langkawi International Convention Centre <input type="checkbox"/> Others: _____
Why do you visit these places?	<hr/> <hr/> <hr/>

Fig. 1

Assess the design of the questionnaire survey as shown in Fig. 1.

[3]

Award 1 mark for each complete point.

Reserve 1 mark for at least one positive and negative aspect of the design.

Answers must comprise both positive and negative aspects of the design.

Positive:

- Most of the questions in the survey address the hypothesis to find out about the popularity of the type of tourism in Langkawi.
- The questionnaire survey comprises of both open and close ended questions which allow for qualitative and quantitative responses.
- Students provide options for 'Others' to take into account alternative answers.

Negative:

- Some of the questions are too personal and sensitive such as the amount of income per month.

- (c) After conducting the questionnaire survey, the students tabulated the following data in Table 1.

Nature of Travel	Number of tourists
MICE	12
Heritage tourism	15
Honeypot	33
Total number of tourists = 60	

Table 1

Justify the conclusion that can be drawn from the information in Table 1 in response to the hypothesis tested and evaluate the reliability of the findings. [4]

Award 2 marks each for justify and evaluate.

Justify:

- The hypothesis is not proven true, ie MICE tourism, is not the most popular type of tourism amongst tourists who visit Langkawi.
- This is because only 12 out of 60 visitors visit Langkawi for MICE in comparison to 48 tourists who visit Langkawi for heritage and honeypot tourism.

Evaluate:

- The findings may not be reliable due to the frequency of the data collection. It was conducted only on one occasion i.e. one weekday afternoon.
- The findings are reliable as the data collection is done concurrently. Hence, the same time of investigation ensures that responses are collected fairly.

- (d) Besides using a questionnaire survey, describe another data collection method that the students can use to determine the popularity of tourism in Langkawi at the 3 sites. [4]

Award 1 mark for each point.

- To determine the popularity of tourism, the students can position themselves at the 3 sites on a similar day and time. They can choose a landmark or the entrance and exit at each site to carry out the investigation.
 - At each site, count the number of visitors entering or leaving the site.
 - Record the number of visitors in the recording sheet by using the tally method.
 - Tabulate the data collected to see which site has the highest or lowest number of visitors during the time of investigation.
- (e) Some of the personal information in the questionnaire in Fig. 1 have not yet been used by the students in their fieldwork investigation.

Suggest a hypothesis for an investigation that the students could carry out linking the personal information to places of visit in Langkawi. [1]

Award 1 mark for one correct point.

- "The higher the income of the visitors, the more likely they are to engage in MICE tourism".
- "The further the country of origin, the more likely they are to engage in heritage tourism".

- (f) The students were also keen to find out about coastal processes at Site 2 (the beach) in Photograph A. The group marked out a line of transect from points A to E as shown in Photograph B.

The students wanted to find out about the type of waves and the size of sediments that are found along the line of transect marked A to E on Photograph B.

The students collected samples of sediments along the transect A to E at a regular interval of 5 m. They measured the sediments collected at each point and compiled the data as shown in Table 2 below.

Distance along transect	A (0m)	B (5m)	C (10m)	D (15m)	E (20m)
Width of sediments in millimetres	13.4	11.1	10.9	14.2	9.0

Table 2

Describe how the results in Table 2 are collected.
Award 1 mark for each point.

[3]

- Along the line of transect A to E, measure the distance of interval 5m starting from Point A near the sea by using the measuring tape and ranging poles.
- Indicate the 5 points i.e. A to E with the ranging poles using the systematic sampling method and collect 100g of the sediments at each point.
- Use the vernier caliper to measure the diameter of the sediments at each site by measuring the widest part (long axis) of the sediments. Record down the measurement. Take the average reading of the sediments at each point.

- (g) Discuss how the students can determine the types of waves along the transect A to E.

[2]

- Students can determine the types of waves by counting the wave frequency. This can be measured by timing the number of waves breaking on the shore in 1 minute. They can take the wave frequency at least three times and find the average wave frequency.

- A low wave frequency (e.g. 6-8 waves per minute) usually indicates constructive waves while a higher wave frequency (e.g. 12-14 waves per minute) usually indicates destructive waves.

(h) With reference to Table 2, draw a scatter graph on the graph paper provided to represent the data and suggest a reason for the anomaly reading. [4]

Award 1 mark for correct points plotted.

Award 1 mark for correct label of X and Y axis.

Award 1 mark for line of best fit.

Award 1 mark for suggest reason. Award any plausible answer.

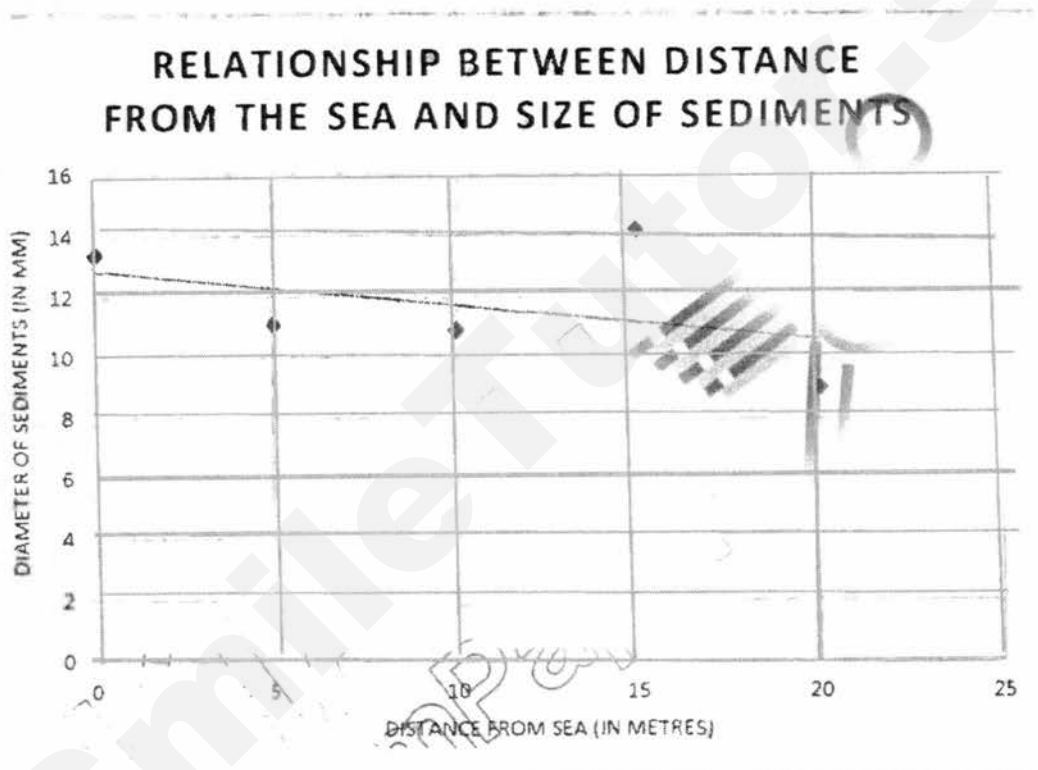

Any one of the following reason:

- The anomaly reading is at Point D which is 15m away from the sea. It has the highest deviation of approximately 3.2mm higher than the line of best fit. This may be due to human interference in which beach activities may move the original sediments from the line of transect.
- The anomaly reading is at Point D which is 15m away from the sea. It has the highest deviation of approximately 3.2mm higher than the line of best fit. This may be due to the changes in tide lines where the coarser sediments are found at the high tide line.

Section B

Answer one question from this section.

2(a) Explain how geology of rocks and types of waves affect the rate of coastal erosion. [4]

Award 1 mark for each point.

Award max 2 marks for each i.e. geology and types of waves

- Rock composition determines the hardness of rocks and their resistance to erosion.
- Harder rocks will erode more slowly than softer rocks when they are being attacked by waves. Hence, the harder the rocks, the slower the rate of coastal erosion.
- Types of waves affects the rate of coastal erosion due to the wave energy and frequency.
- Destructive waves have a higher wave energy and higher wave frequency. Therefore, they have a higher ability to erode rocks through processes like hydraulic action and abrasion. Hence, the rate of coastal erosion is higher in a high energy environment.

- (b) Study Fig. 2 which shows the process of wave refraction as it approaches the coast.

Use Fig. 2 to predict how wave refraction may change the coastline.

[4]

Award 1 mark for each point.

Award max 3 marks if students do not make reference to the figure.

- Wave refraction may change the coastline by straightening it as waves approach the coast.
- When waves approach the coast, the wave energy tends to converge on the headlands, giving rise to increased wave height and greater erosive action.
- When waves approach the bays, wave energy diverge, giving rise to decreased wave height and reduced erosive action.
- Due to the difference in the wave energy at different parts of the coastline, the wave refraction in Fig. 2 will eventually straighten the coast as erosional and depositional processes are more dominant at headlands and bays respectively.

- (c) Fig. 3A shows the distribution of endangered coral reefs in the world. Fig. 3B shows a street map of Coral Bay, which is a popular snorkelling site.

With reference to Fig. 3A and 3B, describe the distribution of endangered coral reefs in the world and explain why they are under threat.

[5]

Award 2-3 marks for description.

Award 2-3 marks for explanation.

Distribution:

- They are largely found in the Philippine and South China Seas along the coastlines of the Southeast Asian region such as Indonesia and Malaysia.
- They are also located along the coastline of Eastern Africa, Madagascar in the Indian Ocean and islands in the Caribbean Sea.

Explain:

- Coral reefs are under threat due to coastal development. The expansion of coastal resorts such as Ningaloo Reef Resort at Coral Bay and the urban development such as shopping centres and cafes increase the likelihood of more waste being deposited into the sea. This may affect the growth of corals as they are suffocated by sediments.
- They are also under threat due to human recreational activities such as snorkelling. When people snorkel at Coral Bay, they may destroy the corals by trampling on them, affecting their growth.
- Tourism activities can also threaten their growth. Tourists' activities such as Glass Bottom Boat rides damage coral reefs when the boat anchors are thrown onto the sea floor.

(d) Study Fig. 4 which shows a type of coastal protection measure.

Describe the type of coastal protection measure in Fig. 4 and assess its effectiveness in reducing the rate of coastal erosion. [4]

Award 2 marks each for description and assess.

Reserve 1 mark each for success and limitation.

Describe:

- The seawall is parallel to the coast and is made up of concrete and hard rocks. There are also rocks accumulated at the bottom of the seawall.
- The wall is steep and has an approximately 45° angle.

Assess:

- Seawalls protect the coastline against wave attack by absorbing wave energy. Waves are reflected back into the sea and hence reduce the rate of coastal erosion.
- However, continuous wave action erodes materials at the base of the seawall. The powerful backwash of the reflected waves undermines the base of the seawall, making it less stable and may lead to the collapse of the seawall.

(e) 'Coastal deposition is responsible for major coastal landforms.'

To what extent is this statement true?

Need a home tutor? Visit smiletutor.sg

Support your answer with examples.

[8]

Level marking	What you need to achieve this level
<p>Level 1 0-3 marks</p>	<p>At this level, answers will be generalized or with minimal support if any given at all. Reasoning is rather weak and expression may be unclear. A basic answer that has little development. Answers lack examples or other evidence, or it is so sketchy that it adds little support to the answer</p> <p><i>Award 1 mark if student merely describes the definition of coastal deposition without addressing the question.</i></p> <p><i>Award 2 marks if student attempts to describe the definition of coastal deposition and lists some of the coastal landforms.</i></p> <p><i>Award 3 marks if student describes the definition of coastal deposition and links to the brief formation of the coastal landforms.</i></p>
<p>Level 2 4-6 marks</p>	<p>Disagreement or agreement will be supported by appropriate detail. Or, both agreement and disagreement are considered, but support is patchy so that the answer is not full. Good reasoning and logic in parts of the answer with good expression in places. Some examples or other evidence will be presented to support answers in at least one place in the answer.</p> <p><i>Award 4 marks if student clearly explains how coastal deposition forms ONE depositional landform i.e. beaches, spits and tombolos (with example).</i></p> <p><i>Award 5 marks if student clearly explains how coastal processes form TWO landforms i.e. depositional and/or erosional such as cliff and shore platform, headland and bay or cave, arch and stack (with examples).</i></p> <p><i>Award 6 marks if student clearly explains how coastal processes form THREE depositional and erosional landforms i.e. cliff and shore platform, headland and bay or cave, arch and stack, beaches, spits and tombolos (with at least 2 examples).</i></p> <p><i>Award max 4 marks if student explains all three factors but without examples.</i></p>
<p>Level 3 7-8 marks</p>	<p>At this level, answers will be comprehensive and supported by sound knowledge. Both agreement and disagreement are considered and well supported. Reasoning is clear and logical with good expression of language. Examples of other evidence to support answers will be extensive.</p> <p><i>Award 7 marks for L2-6 marks if student provides well-explained both coastal depositional and erosional landforms with examples for all and supported by a stand.</i></p> <p><i>Award 8 marks if student provides a well-evaluated conclusion, with good examples, by stating a strong stand based on the role of deposition vis-à-vis erosional processes and its landforms.</i></p>

Sample answer

Need a home tutor? Visit smiletutor.sg

I agree to a small extent that coastal deposition is responsible for some coastal landforms. However, there is another coastal process such as erosion which is also responsible for other coastal landforms.

Coastal deposition may occur when wave energy decreases or sediment weight is too heavy for the waves to carry. Hence, these sediments are deposited along the coast. Landforms such as beaches, spits and tombolos are found along depositional coasts. A spit is formed when there is an abrupt bend in the coastline and longshore drift continue to transport sediments in the original direction for some distance. The sediments are deposited in the sea after the bend where they will accumulate over time along the original direction of the coastline. This creates a ridge of sediments from the point where the coastline changes direction. When the spit continues to grow due to deposition and connects to a nearby mainland, a tombolo is formed, connecting the two existing islands. An example is a spit along Changi Beach in Singapore which continues to grow into the sea. A beach is also formed when sediments accumulate along a sheltered bay as the wave energy decreases, depositing loose sand, gravel and pebbles. An example of a sandy beach is Gold Coast beach along Brisbane coastline. Thus, coastal deposition is responsible for some of the coastal landforms.

However, coastal erosion also creates other landforms. Coastal erosion takes place in four main ways – hydraulic action, abrasion, attrition and solution. Each erosion process creates various landforms. Hydraulic action and abrasion erode a crack or joint on the rock surface and gradually enlarging the crack or joint to form a notch. The notch may be further deepened to produce a bigger hollow space called a cave. Further erosion by the waves eventually causes the roof of the cave to collapse to form a steep cliff. As the process of erosion continues, an overhanging cliff is formed. Eventually, the overhanging cliff will collapse and the materials will be deposited at the foot of the cliff. Some of the materials will be thrown against the base of the cliff, causing further erosion through abrasion. Over time, the cliff will retreat and a gently sloping platform appears at the base, forming a shore platform. An example is the White Dover cliff in United Kingdom, London which faces the Straits of Dover and France. Hence, coastal erosion creates cliffs and shore platforms.

Coastal erosion also creates erosional landforms such as caves, arches and stacks. Within headlands, some rocks may be less resistant to erosion than other rocks. These parts of the headlands will be eroded more quickly by hydraulic action and abrasion. Waves attack lines of weaknesses at the base of the headland and undercut it. The continuous action of waves forms a cave. The energy of waves hitting both sides of the headland may eventually lead to caves being developed on each side of the headland. Further erosion may join caves together, leaving a bridge of rock known as an arch. After a period of time, the roof of the arch may collapse to form a stack, which is a pillar of rock in the sea left behind after an arch collapses. An example will be the arch in Port Campbell Australia and the stacks along the Twelve Apostles in Melbourne. Therefore, coastal erosion is also responsible for the other coastal landforms.

To conclude, I believe that coastal deposition play a role in the formation of coastal landforms such as beaches, spits and tombolos. However, coastal processes are not just limited to that. Coastal erosion also plays a significant role in shaping other coastal formation due to its dynamic processes of hydraulic action, abrasion, attrition and solution. Hence, due to the high energy environment along erosional coastlines, other landforms such as cliffs and shore platforms, headlands and bays and caves, arches and stacks are formed. All in all, I partially agree with the statement that coastal deposition plays a role in the formation of coastal landforms.

3(a) Study Fig. 5 which shows a sketch map of a cliff along a coastline.

Using Fig. 5, explain how erosional processes at A and B can form coastal landforms. [4]

Award 2 marks each for A and B.

A:

- When waves hit the base of the headland at A, the waves trap air in the rock joints. The air is compressed by the oncoming waves, exerting pressure on the joints and eventually weakens the rock and causing them to shatter.
- The eroded rocks are hurled and scraped against the headland through abrasion. This weakens the surface and erosion continues to occur. This creates a small cave at the base of the headland.

B:

- Hydraulic action and abrasion continue to erode the rock surface at the base of the cliff, forming an overhanging cliff.
- The overhanging cliff will eventually collapse as the base is unstable and the materials will be deposited at the base of the cliff. The cliff will retreat inland and a gently sloping platform called shore platform is formed at the base of where the cliff used to be.

(b) Study Fig. 6 which shows a cross section of the changing beach profile before and after a storm.

With reference to Fig. 6 and your own studies, show how the beach profile has evolved and outline how the beach materials are transported to rebuild the beach. [5]

Award max 3 marks for show.

Award max 2 marks for outline.

Show:

- In calm conditions, the beach profile is gentle with slight elevation of about 45° facing the coast. Vegetation can also be seen growing along the beach profile.
- During the storm, the strong waves hit the coast and erode the beach, causing the sand to move offshore. Beach profile becomes steep and almost vertical.
- After the storm, the beach is built from the build-up of wind-blown sand and movement of sand onshore. Beach profile is now gentle.

Outline:

- Beach materials are transported through the longshore drift and beach drift. When waves approach the coast at an angle, sediments move up the beach at an angle as swash and move perpendicularly down the beach as

- The longshore current which is parallel to the coast helps to move the sediments along the beach. Hence, the combined effect create longshore drift which rebuilds the sediments on the beach.

- (c) Study the topographical map extract of Mauritius. The scale is 1:25 000 and contours are shown in 10m intervals.

The location between Eastings 26 and 29 and Northings 94 and 98 is a major tourist area.

With reference to the topographical map, explain why people are attracted to the area. [4]

Award 1 mark for each complete point.

Award max 3 marks if students do not make reference to the names of the landmarks.

- People are attracted to the scenic beauty of the area. It is located along the coastline of Trou D'eau Douce and there are beaches found near Pte Quatre Cocos where tourists can enjoy the scenic beauty. Hence, areas of natural scenic beauty attracts nature lovers.
- There are also major towns such as Lenferna and Victoria where supporting facilities such as accommodation ie, Hotel UC and village halls are provided for the tourists.
- The Crown Land Falmar Reserves also caters to tourists who want to engage in ecotourism where they visit protected nature spaces.
- There is also accessibility to the area as there are major roads connecting to different parts of the islands such as B26 and B59 roads, increasing the number of tourists coming to the area.

- (d) With the aid of examples, assess the socio-cultural impact of tourism. [4]

Award 1 mark for each point.

Reserve 1 mark each for positive and negative impact.

Reserve 1 mark for examples.

- Tourism can bring about the preservation of culture and customs. This will make historical and cultural sites more attractive to tourism. Revenue generated from tourism can also be used to fund the preservation and restoration of the cultural sites.
- For instance, entrance fees to sites such as the Great Pyramids of Giza in Egypt and Angkor Wat in Siem Reap Cambodia have been used to directly fund conservation efforts.
- However, tourism can also cause dilution of culture and local customs. The identity, culture and values of a place can be lost when activities and places become commercialised to meet the demands and expectations of tourists when festivals and rituals are modified.
- Tourism can also cause an increase in crime rates. Tourists carry valuable items and hence may be vulnerable to pickpockets. This can affect the reputation of the place as visitors may be fearful of such incidents.

- (e) 'Affordable transportation is the main influence for the growth of global tourism.'

How far do you agree with this statement?

[8]

Support your answer using examples.

Level marking	What you need to achieve this level
Level 1 0-3 marks	<p>At this level, answers will be generalized or with minimal support if any given at all. Reasoning is rather weak and expression may be unclear. A basic answer that has little development. Answers lack examples or other evidence, or it is so sketchy that it adds little support to the answer.</p> <p><i>Award 1 mark if student merely describes the definition of affordable transportation without addressing the question.</i></p> <p><i>Award 2 marks if student attempts to describe affordable transportation as part of the development in technology.</i></p> <p><i>Award 3 marks if student describes and explains affordable transportation as part of the development in technology and how it influences the growth of tourism.</i></p>
Level 2 4-6 marks	<p>Disagreement or agreement will be supported by appropriate detail. Or, both agreement and disagreement are considered, but support is patchy so that the answer is not full. Good reasoning and logic in parts of the answer with good expression in places. Some examples or other evidence will be presented to support answers in at least one place in the answer.</p> <p><i>Award 4 marks if student describes and explains affordable transportation as part of the development in technology and how it influences the growth of tourism (with examples).</i></p> <p><i>Award 5 marks if student describes and explains another factor related to DEMAND and how it influences the growth of tourism (with examples).</i></p> <p><i>Award 6 marks if student describes and explains a third factor related to DESTINATION factor and how it influences the growth of tourism (with at least 2 examples).</i></p> <p><i>Award max 4 marks if student describes and explains all three factors but without examples.</i></p>
Level 3 7-8 marks	<p>At this level, answers will be comprehensive and supported by sound knowledge. Both agreement and disagreement are considered and well supported. Reasoning is clear and logical with good expression of language. Examples of other evidence to support answers will be extensive.</p> <p><i>Award 7 marks for L2-6 marks and link the ALL THREE factors (with examples) to the growth of tourism and provided a stand.</i></p> <p><i>Award 8 marks if student provides a well-evaluated conclusion, with good examples, by stating a stand with strong reasoning that accounts for it</i></p>

Sample essay

I agree that affordable transportation is the main influence for the growth of global tourism. The rise of budget airlines has made air transport affordable especially those from middle and low income-groups, to travel. The cheapened air fares can be attributed to smaller and more fuel-efficient aircrafts. These aircrafts such as Jetstar, Airasia and Tiger Airways typically fly mainly to short-haul destinations. Hence, this would definitely enable more people to travel internationally and more frequently. It also enables travellers to go to destinations not covered by major commercial airlines such as Bhutan, Pacific Islands, Northern Thailand and many other islands. This thus leads to the growth in global tourism.

However, destination factor can also influence the growth of global tourism. Destination factor refers to the infrastructure and services in tourists destinations that allow for more convenient and comfortable stays for tourists. The provision of attractions can offer something spectacular, unique and interesting for both domestic and international tourists. Such attractions can also attract tourists to make return trips to the country to spend their tourists' dollars. For instance, Dubai has become a major destination and stopover location between Europe and Asia. The Burj Al Arab and Palm Islands showcased a seven star luxury hotel on artificial islands. Thus, the promotions of attractions, natural or built, draw tourists to visit the country and boost the tourism industry.

Demand factors also affect the growth of tourism. They influence people's desire to purchase tourism-related goods and services. Disposable income is one of the reasons for the growth in tourism. Disposable income is the amount of income left after taxes have been paid. The growth in income has allowed people to spend more on travelling for leisure. Due to the rapid economic growth such as in China and India, the number of people in the middle income and high income groups has been steadily growing. Hence, having more disposable income, they have the ability to spend more on travel, boosting its growth.

In conclusion, I believe that the provision of affordable transportation through fuel-efficient aircrafts have revolutionized the way tourists travel. Without this effective and efficient mode of transport, tourists may not be able to reach such destinations. In addition, even if attractions are highly publicized, they may not be able to reach the areas if there is no accessibility of transportation. Moreover, when more people can afford to travel, travel eventually becomes a lifestyle and hence there will be a significant increase in tourist arrivals in various destinations. Hence, affordable transportation is the main influence for the growth of global tourism.

-End of paper-

Section A

Answer one question from this section.

- 1(a) Study Figs. 1A and 1B. Fig 1A shows the elevation map of Australia and Fig. 1B describes the relationship between air pressure and altitude.

With reference to Fig. 1A and 1B, describe the elevation in Australia and account for the difference in pressure at difference locations.

Award max 3 marks for description.

Award max 2 marks for account for.

Description:

- The elevation in Australia ranges from below sea level to above 600m. [5]
Areas that have high elevation of above 600m are generally found along the Northeast and Southeast coast of Australia where Mount Koscuiszko and Bartle Frere are found. It is also found at the Western coast where Mount Meharry is located.
- Areas with moderate elevation between 300 to 600m are largely found surrounding the areas with high elevation, particularly in Western and Central Australia. These areas are surrounding Mount Woodroffe, Mount Zeil and Mount Meharry.
- Areas with low elevation between 0m to 300m are generally found in Northern and Southern coast of Australia. These areas are also in some parts of Central Australia.

Account for:

- Air pressure decreases as altitude increases. For instance, when the altitude is 152m, the air pressure is 994.8m and when altitude rises to 610m, air pressure drops to 942.1m. This is because the air becomes less dense at higher altitudes.
- Gravity pulls air molecules towards the surface of the earth. Hence, air pressure is higher at sea level and lower at higher altitudes.

- (b) Fig. 2 shows a regional wind system that brings rain to Central Asia.

Using Fig. 2, explain the occurrence of floods at Bangladesh.

[4]

Award one mark for each point.

- Bangladesh experiences the Southwest monsoon between June to September when it is summer in the Northern Hemisphere.
- The hot air over Central Asia heats up, expands and rises, forming a region of low pressure over the area. During the same time, the Southern hemisphere is experiencing winter, creating an area of high pressure.

- Due to the difference in pressure, air from Southern Hemisphere moves to Central Asia. As the winds cross the Equator, Coriolis effect deflects the winds to the right, bringing Southwest monsoon winds across the Bay of Bengal to Central Asia and Bangladesh.
- The warm air picks up moisture as it travels over the Indian Ocean and brings heavy rain to Bangladesh, causing flooding.

(c) With the use of examples, comment on the effectiveness of responses to climate change at the national level. [4]

Award 1 mark for each point.

Reserve 2 marks each for successes and limitations.

Reserve 1 mark for examples.

- The Singapore Green Plan aims to generate 60% of Singapore's energy needs using natural gas in 2012. Natural gas is a cleaner form of energy in comparison to coal because it produces less smoke. With the switch to natural gas as an energy source, there is **less reliance on coal** to produce electricity. This thus reduces the **amount of toxic by product gases** that are released into the atmosphere.
- However, natural gas requires complex treatment plants to process and pipelines to transport. These pipelines have high maintenance costs because they need to be laid underground and have to be checked regularly for leakage.
- Another national strategy is the Green Mark Scheme. The scheme aims to encourage more new 'green' buildings, which are energy-efficient. Buildings that are more energy-efficient use less energy to produce the same service. Some successes include the existing green buildings such as Plaza by the Park and National Library Building. They have reported energy savings of 15% to 35% compared to conventional buildings. This cuts down greenhouse gas emissions by reducing fossil fuels to generate electricity.
- However, these buildings are more costly because the construction materials are more expensive as such materials may include recycled metal.

(d) Study Fig. 3 which shows an infographic of human activities on the environment.

Using Fig. 3, explain how human activities contribute to the increase in global temperature. [4]

Award 1 mark for each point.

Award max 3 marks if no reference is made to the figure ie, values.

- Transportation in urban areas (19% of the total greenhouse gas emission) in New Zealand contributes to the emission of greenhouse gases through its exhaust fumes. More fossil fuels are also burnt, emitting carbon dioxide.

greenhouse gas, traps heat in the atmosphere and leads to enhanced greenhouse effect, causing an increase in global temperature.

- The burning of fossil fuels for energy consumption in urban areas (26% of the total greenhouse gas emission) in New Zealand has resulted in an increased emission of nitrous oxide. These gases are released into the atmosphere and traps heat to cause enhanced greenhouse effect, causing an increase in global temperature.
- Industrial economic activities are also responsible for the increase in global temperature. This takes up 6% of the total greenhouse gas emission. Secondary industries such as manufacturing involve the burning of fossil fuels. Greenhouses gases are also released as by-products when goods are produced. Thus, these gases are released into the atmosphere and traps heat to cause enhanced greenhouse effect, causing an increase in global temperature.
- Agriculture takes up the largest percentage of 47% of the total greenhouse gas emission in New Zealand. Cattle farming contributes to greenhouse gas emissions because cattle release methane as waste gas, which account for 35% of methane released into the atmosphere. These gases trap heat to cause enhanced greenhouse effect, causing an increase in global temperature.

- (e) 'The differential rate of heating of land and sea is responsible for the variation in temperature at different locations.'

Discuss the accuracy of the statement.

Use examples to support your answer.

[8]

Level marking	What you need to achieve this level
Level 1 0-3 marks	<p>At this level, answers will be generalised or with minimal support if any stand were given at all. Reasoning rather weak and expression may be unclear. A basic answer that has little development.</p> <p><i>Award 1 mark if students briefly define the concept of differential rate of heating of land and sea.</i></p> <p><i>Award 2 marks if students briefly describe distance from the sea as a factor affecting temperature at different locations.</i></p> <p><i>Award a max of 3 marks if students provide description of distance from the sea and link to variation in temperature at different locations.</i></p>
Level 2 4-6 marks	<p>Agreement or disagreement will be supported by appropriate detail. Or, both agreement and disagreement are considered, but support is patchy so that the answer is not full. Good reasoning and logic in parts of the answer with good expression in at least one place in answer.</p>

	<p><i>Award 4 marks if students are able to give a well-explained paragraph showing how distance from the sea can affect temperature at different locations (with specific example).</i></p> <p><i>Award 5 marks if students are able to provide a well-explained paragraph of another factor affecting temperature (ie, altitude, latitude or cloud cover) of different locations (with specific examples for both)</i></p> <p><i>Award 6 marks if students are able to provide a well-explained paragraph of the third factor affecting temperature (ie, altitude, latitude or cloud cover) of different locations (with at least 2 with examples)</i></p> <p><i>Award a max of 4 marks if students provided well-explained paragraphs of all three factors but there are no examples given.</i></p>
<p>Level 3 7-8 marks</p>	<p>At this level answers will be comprehensive and supported by sound knowledge. Both agreement and disagreement are considered and well supported. Reasoning is clear and logical with good expression of language.</p> <p><i>Award 7 marks if students are able to hit L2/6 with all three examples.</i></p> <p><i>Award 8 marks if students are able to provide a logical conclusion that clearly shows their stand of evaluating the importance of the factors in influencing temperature at different locations.</i></p>

Sample essay

I agree with the statement to a small extent. Due to the difference in the rate of heating, maritime and continental effect affects the temperatures at different locations.

The sea heats up and cools down more slowly than the land. The difference in the rate of heating and cooling of the sea and land affects temperature of coastal and inland areas. During summer, land heats up faster than the sea, causing cooler sea air to lower the temperature of coastal areas. During winter, the sea cools more slowly than the land. As the sea retains heat longer, the warm air over the sea increases the temperature of coastal areas. Thus, due to maritime effect, coastal areas experience cooler summer and warmer winters.

In inland areas, they are not influenced by the difference of heating of the land and sea. Hence, inland areas experience warmer summers and colder winters, leading to a large annual temperature range than coastal areas. For instance, the two cities in Alaska, Fairbanks and Anchorage experience different mean monthly temperatures. Fairbanks, which is a city further inland, experiences harsh winter and summer with a large annual range of temperature. Anchorage, a coastal city, experiences a cooler summer and warmer winters as the sea regulates the temperature. Thus, the differential rate of heating of land and sea arising from the distance from the sea contributes to the maritime and continental effect, leading to varying temperature at different locations.

However, there are other factors such as latitude that affect the variation in temperature at different locations. Latitudes are imaginary horizontal lines running from east to west around the earth and are measured in degrees. The temperature differs between places at lower latitudes and higher latitudes because the sun's rays strike various parts of the world at

The earth tilts at 23.5° on its own axis. As a result, the sun's rays strike at various angle at different parts of the earth. The angle of incidence is the angle at which the sun's rays reach the earth. When the angle of incidence is higher, the sun's rays are more concentrated on the area. The tilt of the earth also results in some places not receiving sunlight for months. For instance, as the angle of incidence is high at the area between Tropic of Cancer (23.5°N) and the Equator, heat from the sun is concentrated on a small area. This results in higher temperature at lower latitudes such as Indonesia and Malaysia in comparison to countries in the higher latitudes such as Russia and Sweden. Thus, latitude is also responsible for the varying temperature at different locations.

Altitude is another factor that affects the variation in temperature at different locations. Temperature decreases with altitude, which is the height of a place in relation to the sea level. Temperature generally decreases by 6.5°C with every 1000 metres increase in altitude. This is because the atmosphere is mostly heated by the earth's surface. The sun's solar energy enters the atmosphere and reaches the earth's surface in the form of shortwave radiation. About 45% of shortwave radiation is absorbed by the earth's surface, heating it up. The warm surface then emits heat in the form of longwave radiation. The higher up the atmosphere, the further it is from the surface of the heated ground. Temperature is therefore lower at the mountainous areas such as Genting Highlands in Malaysia in comparison to low-lying areas such as Kuala Lumpur in Malaysia. Thus, altitude is also responsible for the varying temperature at different locations.

In conclusion, I agree to a small extent that the differential rate of heating of land and sea is responsible for the variation in temperature at different locations. This is because there is an obvious variation of temperatures between coastal and inland areas. However, I believe that latitudes play a major role in affecting the temperature at different locations. This is because latitudes explain the main reason of the varying temperature across the global scale, affecting the climate of a location. It determines the baseli temperatures before other factors come into play. However, I also acknowledge that the other 2 factors, distance from the sea and altitudes also affect temperature between locations albeit at a local scale.

2(a) Study Figs 4A and 4B on Cyclone Sandy which hit United States of America in 2012.

- (i) Using Fig. 4A and your own studies, describe the characteristics of Cyclone Sandy and outline the factors affecting its strength and spinning direction. [4]

Award max 2 marks for description.

Award max 2 marks for outline.

Description:

- Cyclone Sandy has thick thunderstorm clouds surrounding the eye of the cyclone. In the centre of the cyclone, there is an area of low central pressure known as the eye of the cyclone.
- It is characterised by its strong winds of 75mph and it spirals towards the eye of the cyclone.

Outline:

- The strength of a cyclone is affected by the high ocean surface temperature. When the temperature is above 26.5°C , the heat and

moisture from the ocean waters allow cyclones to be formed as hot air rises and latent heat is released to sustain the cyclone.

- The direction of a cyclone is also affected by Coriolis Effect as it helps to create the rotary motion of the cyclones. In the Northern hemisphere, the Coriolis effect deflects winds to the right, causing the cyclone to rotate in an anti-clockwise direction. In the Southern hemisphere, the Coriolis Effect deflects winds to the left, causing the cyclone to rotate in a clockwise direction.

- (ii) Using Fig. 4B, describe the path taken by Cyclone Sandy and discuss its damage. [5]

Award 2 marks for description.

Award 3 marks for discuss.

Describe:

- Cyclone Sandy started in the ocean near Jamaica and moves in the North direction towards Cuba and the Bahamas.
- It then changes the course of the direction towards the Northeast before moving in the Northwest direction and hitting the USA.

Discuss:

- Tropical cyclones can cause great damage to houses and properties of people living in the area. According to Fig. 4B, 4903 houses are damaged and 137,000 houses are affected in Dominican Republic and Cuba respectively.
- Lives may also be lost as people are trapped in their damaged houses or injured by the strong winds. According to Fig. 4B, 54 people have been reported dead in Haiti and 40 deaths in USA.
- Severe floods can cause destruction to farmlands and other infrastructure as the tropical cyclone causes damage to plants, cattle farms and other services. This will affect transportation networks and supply of food to the affected places.

- (b) Fig. 5 shows a formation of tsunami.

With reference to Fig. 5 only, account for the formation of tsunami. [4]

Award 1 mark for each point.

- Tsunami occurs due to an explosive volcanic eruption in the sea. When a volcano erupts, magma reaches the surface and explodes.
- The violent explosion causes the original top of the volcano to be unstable and the materials slide down into the sea.
- Some of the volcano flank crashes into the sea, causing these materials to plunge into the water.
- Tsunami is thus formed as large waves are generated from the explosion and the landslide causing these large waves of high heights to reach

- (c) Assess the impacts of volcanic eruption on the economy and the local community. [4]

Award max 2 marks each for benefits and risks.

Allocate 2 marks each for economy and local community.

- One benefit of volcanic eruption is the availability of fertile soil. The lava and ash from volcanoes break down to form fertile soil. The fertile soil is rich in minerals which makes it favourable to agriculture. This will help to increase food supply for the local community.
- Volcanic areas are often popular tourist attractions. Volcanic areas offer a variety of activities for tourists to engage in. The scenic beauty of volcanic landscapes can attract tourists. Hence, such tourist activities can bring in income for the people living in the volcanic area and this can help to develop the country's economy.
- However, volcanic materials made up of pyroclasts, volcanic gases, ash and dust are being released during the eruption, leading to a widespread damage of infrastructure such as houses and transportation networks. With such damage, the economy will temporarily come to a standstill.
- Pyroclastic flow also cause loss of lives as the lava destroys everything in its path as it travels down the volcano.

- (d) 'Major tectonic landforms and features are formed at convergent plate boundaries.'

To what extent is the statement true?

Support your answer with examples.

[8]

Level marking	Description
Level 1 0-3 marks	<p>At this level, answers will be generalized or with minimal support if any given at all. Reasoning is rather weak and expression may be unclear. A basic answer that has little development. Answers lack examples or other evidence, or it is so sketchy that it adds little support to the answer.</p> <p><i>Award 1 mark if student states the three types of plate movements without any description.</i></p> <p><i>Award 2 marks if student provides some brief description of convergent plate movements.</i></p> <p><i>Award 3 marks if student provides well-explained paragraph on the tectonic landforms found at convergent plate boundary.</i></p>
Level 2 4-6 marks	<p>Disagreement or agreement will be supported by appropriate detail. Or, both agreement and disagreement are considered, but support is patchy so that the answer is not full. Good reasoning and logic in parts of the answer with good expression in places. Some examples or other evidence will be presented to support answers in at least one place in the answer.</p>

	<p><i>Award 4 marks if student provides well-explained paragraph on the tectonic landforms found at convergent plate boundary (with specific examples).</i></p> <p><i>Award 5 marks if student provides another well-explained paragraph on the tectonic landforms found at divergent plate boundary (with specific examples).</i></p> <p><i>Award 6 marks if student provides well-explained paragraphs of all three plate movements (convergent, divergent and transform) and its landforms (with at least 2 specific examples).</i></p> <p><i>Award max 4 marks if student provides well-explained paragraphs of all three plate movements (with no examples).</i></p>
<p>Level 3 7-8 marks</p>	<p>At this level, answers will be comprehensive and supported by sound knowledge. Both agreement and disagreement are considered and well supported. Reasoning is clear and logical with good expression of language. Examples of other evidence to support answers will be extensive.</p> <p><i>Award 7 marks if students are able to hit L2/6 and provide 3 examples.</i></p> <p><i>Award 8 marks if student is able to provide a logical conclusion that remains constant throughout the answer (Disagree/Agree to show extent with supporting evidence from two other plate movements).</i></p>

Sample essay

I agree to a large extent that major tectonic landforms are formed at convergent plate boundaries. There are three types of plate movements. Each type of plate movement at different plate boundaries will result in the formation of different types of features and landforms on the earth's crust. Convergent plate movements mainly forms tectonic landforms on the earth's crust.

At the convergent plate boundaries, convergent plate movement occurs when plates move towards each other. In oceanic-oceanic convergence, the denser oceanic plate subducts below the less dense oceanic plate. At this subduction zone, a depression called oceanic trench is formed and the subducted plate will be melted and rise as magma to form volcanoes. An example is the Marianas Trench and Marianas Island when Pacific Plate and Philippines plate collide. In continental-continental convergence, fold mountains may be formed as the crusts are compressed and folded upwards due to compressional force acting on the plates. An example will be the Himalayas, between Indian and Eurasian Plate. In oceanic-continental convergence, all the three landforms- trenches, volcanoes and fold Mountains may be formed due to the different densities of the plates.

However, there are also other tectonic landforms found along divergent plate boundaries. Divergent plate movement occurs when two plates move away from each other. Magma moves upward to the surface where it cools to form new oceanic crust along these plate boundaries. In oceanic-oceanic plate divergence, magma rises from the mantle to fill the gap between the plates as they move apart to create a ridge of new ocean floor known as mid-oceanic ridge. Volcanic islands may also be formed when magma solidifies and rise above sea level. An example is the Mid-Atlantic Ridge between North American Plate and Eurasian Plate. In continental-continental divergence, a rift valley is formed when the land in between the two continental plates sink due to tensional forces acting between them. An example is the East African Rift Valley.

There are also tectonic features along transform plate boundaries. Transform plate movement occurs when two plates slide past each other along transform plate boundaries. The movement results in the formation of a transform fault. In the process, tremendous stress builds up and is eventually released through the form of earthquakes. One feature along the transform plate boundary is the San Andreas Fault between the Pacific Plate and the North American Plate. When the two continental plates slide past each other, it creates a fault line in between the two plates.

Hence, we can see how different plate movements at different plate boundaries result in the formation of different features and landforms on the earth's crust due to its different densities and directions of plate movements. However, I agree that convergent plate movement creates more landforms and features but I acknowledge that there are also other forms of plate movements that are responsible for other tectonic landforms.

Section B

Answer one question from this section.

- 3(a) Study Fig. 6 which shows the calories consumed **per capita** per day in China and India from 1980 to 2013.

Using Fig. 6, compare the changes in the calories between China and India from 1980 to 2013 and discuss the effects of malnutrition on developing countries.

[5]

Award 3 marks for comparison.

Award 2 marks for discuss.

Comparison:

- Generally, China sees a higher calories consumed per capita per day in comparison to India. China shows an increase of 950 (3100-2150) calories consumed per capita per day while India sees an increase of 400 (2400-2000) calories consumed per capita per day. This shows that China increases 500 calories consumed per capita per day more than India from 1980 to 2013.
- Between 1980 and 1990, China shows an increase of 350 (2500-2150) calories consumed per capita per day while India shows an increase of 200 (2200-2000). This shows that China increases 150 calories consumed per capita per day more than India from 1980 to 1990.
- Between 1990 and 2013, China shows a rapid increase of 600 (3100-2500) calories consumed per capita per day while India shows an increase of 200 (2400-2200) calories consumed per capita per day. This shows that China increases by three times more calories consumed per capita per day than India from 1990 to 2013.

Discuss:

- Malnutrition can lead to adverse effects on the health of the people. With malnutrition, people in LDCs do not get sufficient amount of nutrients and hence may affect their developmental growth. The lack of nutrients can result in poor health conditions such as visual impairment or even deaths.

- Malnutrition can affect the country's economic development. When people suffer from malnutrition, they get sick easily, leading to loss of working days. Hence a lower income is generated and thus lowering the country's productivity.
- Obesity-related diseases may also demand more public health expenditure and governments would have to channel more funds to the health care system. This would reduce the amount of funds remaining for economic development.

(b) Study Fig.7 which shows the dominant soil stresses in the world.

Using Fig. 7, explain how poor soil fertility and drainage can affect food production. [2]

Award 1 mark for each point.

Award max 1 mark if no reference is made to the values.

- Poor soil fertility can reduce the amount of food production. When the soil is infertile, it lacks nutrients and minerals that are essential for crops to grow. Hence, crops may not grow well in such quality of soil, reducing its output. For instance, 4.5 million km² of global land area are experiencing excessive nutrient leaching and 3.5 million km² of global land area are experiencing low moisture and nutrient status.
- Soil drainage is also dependent on the ability to hold water in the soil. Improper soil drainage may hinder the growth of crops. When the soil is not properly drained, water will be too much or too little for crop production as plants require water to grow well. For instance, 2.6% of total global land area experiences low water-holding capacity. Hence, crop yield may be adversely affected.

(c) Study Fig. 8 which shows an infographic of modern developments in farming.

Using Fig. 8, show how modern developments in farming can boost food security. [5]

Award 1 mark for each point.

- Availability of new technology will affect food production and supply. Technological advances such as machineries, pesticides and high-yielding varieties seeds can increase productivity and supply, therefore improve food security.
- Food security can be increased by implementing agricultural policies. The government can channel resources into farmer's development and education or ensure food prices are stable to influence the intensity of food production and ensure accessibility of food.
- Diversifying sources of food also allows food supply to be steady and secure. Food supply is assured as the government increases the quantity and

- GM food also helps to stabilise crop yield as GM crops are made to be pests and weather resistant. Hence, less crops are destroyed to unfavourable weather conditions such as low rainfall and pests attacks, increasing food supply and boosting food security.
 - Organic farming is also another modern development in farming as it provides an alternative food supply that are grown without the use of chemical fertilisers or growth hormones and hence increase health benefits. Thus this allow another option for people to consume food that are relatively safer, improving the food security.
- (d) Using an example, discuss the successes and limitations of genetically modified food in tackling the issue of food shortage. [5]

Award 1 mark for each point.

Reserve 1 mark for example.

Successes:

- Genetically modified (GM) crops have higher yield than non-GM crops due to the modification of the seeds. This helps farmers to increase the food productivity as there is higher output, minimising the issue of food shortage.
- The use of biotechnology has also enabled food to be produced in areas previously considered unsuitable for agriculture. Crop yield is stabilised as GM crops are more resistant to extreme weather conditions, increasing food productivity.

Limitations:

- GM food crops are expensive and so not all farmers can afford to invest in GM food. Hence, this may lead to the dominance of agribusinesses. The latter is more financially-equipped and is able to afford the high capital investment. Small-scale farmers and LDCs will not be able to afford the GM seeds due to the high price. Hence, food productivity will remain low in LDCs.
 - Many consumers are wary of consuming GM food due to the potential health risks associated with them. As a result, GM food is small as the demand for them is low.
 - GM food crops are mainly used to increase yield of selected food crops and not staple food. This is also due to the rise in demand for biofuels for the running of the economy in DCs. Hence, GM crops do not effectively meet the demand for food consumption in LDCs.
 - For instance, only corn, soya bean and canola uses GM biotechnology but it is limited to other crops that are important in Sub-Saharan Africa such as cassava and banana.
- (e) 'The variation in food consumption patterns in different countries is mainly due to economic reasons.'

How far do you agree with this statement?

Need a home tutor? Visit smiletutor.sg

Support your answer using examples.

[8]

Level marking	Description
Level 1 1-3 marks	<p>At this level, answers will be generalized or with minimal support if any given at all. Reasoning is rather weak and expression may be unclear. A basic answer that has little development. Answers lack examples or other evidence, or it is so sketchy that it adds little support to the answer.</p> <p><i>Award 1 mark if student is able to define economic reasons in variation of food consumption.</i></p> <p><i>Award 2 marks if student is able to briefly describe economic reasons in variation of food consumption.</i></p> <p><i>Award 3 marks if student is able to explain the economic factor that can cause food consumption patterns to vary in different countries.</i></p>
Level 2 4-6 marks	<p>Disagreement or agreement will be supported by appropriate detail. Or, both agreement and disagreement are considered, but support is patchy so that the answer is not full. Good reasoning and logic in parts of the answer with good expression in places. Some examples or other evidence will be presented to support answers in at least one place in the answer.</p> <p><i>Award 4 marks if student is able to clearly explain one economic factor that can cause food consumption patterns to vary in different countries (with examples)</i></p> <p><i>Award 5 marks if student is able to clearly explain another factor (ie, political or socio-cultural) that can cause food consumption patterns to vary in different countries (with examples).</i></p> <p><i>Award 6 marks if student is able to clearly explain two other factors (ie, political and socio-cultural) that can cause food consumption patterns to vary in different countries (with at least 2 examples).</i></p> <p><i>Award max 4 marks if student is able to clearly explain the economic factor that can cause food consumption patterns to vary in different countries, but with no examples.</i></p>
Level 3 7-8 marks	<p>At this level, answers will be comprehensive and supported by sound knowledge. Both agreement and disagreement are considered and well supported. Reasoning is clear and logical with good expression of language. Examples of other evidence to support answers will be extensive.</p> <p><i>Award 7 marks if students are able to hit L2/6 with 3 examples and provide a conclusion to support their stand.</i></p> <p><i>Award 8 marks if students are able to provide a logical conclusion that clearly shows their stand of evaluating the factors that can cause food consumption patterns to vary in different countries.</i></p>

Sample essay

I agree that the variation in food consumption patterns in different countries is mainly due to economic reasons.

Economic factors can cause food consumption patterns to vary in different countries, particularly between LDCs and DCs. Rising income results in higher disposable income in

every US \$1 increase in income only 20% of increased income is spent on food. In contrast, in LDCs such as Democratic Republic of the Congo, up to 60% of the increased income goes to spending on food. When people have more disposable income, they have more purchasing power to consume a larger amount and variety of food. Often, this means consuming more meat and less cereal as they are able to afford such food. With higher disposable income in DCs, the quality of diets also tends to increase due to consumption of organic food and olive oil which have certain health benefits. Thus, economic reason largely affects the consumption patterns in different countries.

Another reason for the variation in food consumption is socio-cultural reasons. Modern society's emphasis on convenience has led to the emergence of many fast food outlets throughout DCs. Due to such convenience and affordable pricing, more people opt to dine at these outlets. However, there are also health concerns linked to the consumption of fast food. These concerns arise from the large amounts of oil, processed meats and chemicals used to prepare fast food. Due to the increasing awareness of the harmful effects of consuming fast food, people in DCs are trying to move away from their high levels of consumption of fast food. However, the fast rate of globalisation has made it possible for fast food chains to set up restaurants in many LDCs such as India. In 1991, when India opened up its economy to foreign investors, many fast food chains such as McDonald's and Pizza Hut were established. Hence, this results in a higher consumption of fast food in LDCs, leading to a higher consumption of fats.

Political reasons are another cause for the variation in food consumption patterns in different countries. Governments can influence the stability of food supply and food safety in their countries. Therefore, food consumption varies between DCs and LDCs. Governments may take action either by increasing food production or increasing food imports. As DCs have financial capacity, they are able to improve farming technology and increase the use of agricultural land by opening new areas for agriculture. This in turn will increase the crop yield and ensure that the food supply of the country is met. LDCs, on the other hand, may not be financially capable and hence they may have a lower ability to increase food supply due to the lack of access to farming technology. Moreover, when there is a civil war or natural disasters, LDCs may be not as well equipped to recover from the loss of croplands for their food supply and hence, food consumption will be adversely affected when such situations occur. Therefore, political reasons will affect the variation in food consumption patterns in different countries as governments play a big role in ensuring that food supply remains stable.

In conclusion, I agree that economic reasons are mainly the cause of variation in food consumption patterns in different countries. Economic reasons such as disposable income will directly affect the affordability of certain food groups and the access to other non-staple food. With a higher disposable income, people have a greater purchasing power to consume. Socio-cultural reasons, in comparison, play a smaller role as it is largely based on the individual preferences and they may choose to consume fast food or otherwise despite its availability. Political reasons such as civil strife and natural disasters, are temporary and hence may not affect the food consumption pattern in the long run. Thus, I believe that economic reasons are the main cause of variation in food consumption patterns in different countries, particularly in DCs and LDCs.

4(a) Study Fig. 9 which shows the consumption of meat and fish in Europe.

Using Fig. 9, compare the trends of chicken and beef between 1979 and 2004 and account for its patterns.

Award max 3 marks for comparison.

Award max 2 marks for account for.

Comparison:

- Generally, the consumption of chicken in Europe shows an increase of 115 (255-140) grams per person per week but the consumption of beef in Europe shows a decline of 110 (220-110) grams per person per week from 1979 to 2004.
- Between 1979 and 1989, the consumption of chicken rises significantly by 50 (190-140) grams per person per week but the consumption of beef shows a slight decrease by 15 (215-200) grams per person per week. Thus, consumption of chicken shows a greater change of 35 grams per person per week in comparison to consumption of beef.
- Between 1989 and 2004, the consumption of chicken continues to rise drastically by 60 (250-190) grams per person per week but the consumption of beef shows a sharp decrease by 90 (200-110) grams per person per week.

Account for:

- The rise in the consumption of chicken is due to a higher disposable income in Europe. This allows people to have a higher purchasing power to buy more chicken as a source of protein. Hence, the consumption of chicken rises as people can afford to consume such meat.
- However, the decline in consumption pattern of beef is probably due to health awareness. In DCs such as Europe, people may prefer to consume less red meat and fast food as they are more conscious of their health.

(b) Study Fig. 10 which shows the supply chain of a local food hub.

With reference to Fig. 10 and your own studies, explain how food security can be improved in a local community. [4]

Award 1 mark for each point.

- Food security can be improved through the establishment of the local food hub. Local partner farms made up of small family farms and specialty producers produce local crops for the consumption of the local community.
- The local farm sourced food is then distributed through local partner distributors, institutions and retailers. Food is then sold at supermarkets and food outlets for consumers to purchase.
- The local food hub also engages community partners consisting of non-profits, hunger and food access organisations and schools to increase awareness of food production and food security as they are the agent of change.
- At the same time, public knowledge on local food security is shared to all segments of the community to spread general knowledge on food production and consumption.

With reference to Fig. 11 and your own studies, show how relocation diffusion causes the spread of the Zika virus and account for its spread.

[3]

Award max 2 marks for show and account for.

Reserve 1 mark for show and account for.

Show how:

- Relocation diffusion is responsible for the spread of Zika virus as it spreads the disease to a location outside its current geographic range. It originated from Uganda and Brazil in 1947 and Brazil in 2015 respectively before spreading to other parts of the world.
- The spread of Zika virus occurs when there is movement of peoples from one location to another, spreading the disease to islands of French Polynesia and Southeast Asian region such as Malaysia, Philippines and Cambodia.

Account for:

- The development of modern transportation has helped in spread of the Zika virus. It allows people to move, relocate and migrate from one place to another faster, increasing the rate and frequency of spread.
- Tourism also contributes to the spread of the virus. As many people travel due to an increased in disposable income, they may be in contact with the virus at the host country and unknowingly spread the disease back in the home country upon their return.

- (d) Using examples, evaluate the role of individuals and international organisations in managing the spread of diseases.

[5]

Award 1 mark for each complete point.

Reserve 1 mark for examples.

Successes and limitations of each role must be considered.

- Individuals can manage the spread of diseases by exercising social responsibility. By being constantly aware of the conditions that encourage the spread of diseases, it allows individuals to take precautionary measures.
- However, not all individuals are aware of such diseases due to low literacy rate and may be involved in risk-taking behaviours that could make a person more likely to contract the disease.
- International organisations are also important in managing the spread of diseases. Being a larger body of organisation, the programmes of education, prevention and treatment have a wider scope of impact as they have the resources to carry out these programmes.
- For instance, the UNAIDS support helped to ensure the successful agreement between the government of Kenya and the Global Fund for the implementation of its Round 10 grants of US\$483 million.
- However, despite the widespread commitment to help curb the spread of diseases, cooperation and execution of strategies from the government prove to be challenging. Thus, the outcome is not satisfactory.

- (e) 'Investment and access to healthcare plays the most important role in determining the health levels of a country.'

Discuss the accuracy of this statement.

Support your answer with examples.

[8]

Level marking	Description
Level 1 0-3 marks	<p>At this level, answers will be generalized or with minimal support if any given at all. Reasoning is rather weak and expression may be unclear. A basic answer that has little development. Answers lack examples or other evidence, or it is so sketchy that it adds little support to the answer.</p> <p><i>Award 1 mark if student is able to define investment and access to healthcare.</i></p> <p><i>Award 2 marks if student is able to briefly describe investment and access to healthcare and link to health levels.</i></p> <p><i>Award 3 marks if student is able to explain investment and access to healthcare and show clear links to health levels.</i></p>
Level 2 4-6 marks	<p>Disagreement or agreement will be supported by appropriate detail. Or, both agreement and disagreement are considered, but support is patchy so that the answer is not full. Good reasoning and logic in parts of the answer with good expression in places. Some examples or other evidence will be presented to support answers in at least one place in the answer.</p> <p><i>Award 4 marks if student is able to explain investment and access to healthcare and show clear links to health levels (with examples).</i></p> <p><i>Award 5 marks if student is able to explain another factor (i.e. social or environmental) and show clear links to health levels (with examples).</i></p> <p><i>Award 6 marks if student is able to explain another factor (is, social and environmental) and show clear links to health levels (with at least 2 examples).</i></p> <p><i>Award max 4 marks if student is able to explain investment and access to healthcare and show clear links to health levels (without examples).</i></p>
Level 3 7-8 marks	<p>At this level, answers will be comprehensive and supported by sound knowledge. Both agreement and disagreement are considered and well supported. Reasoning is clear and logical with good expression of language. Examples of other evidence to support answers will be extensive.</p> <p><i>Award 7 marks if students are able to hit L2/6 with three examples.</i></p> <p><i>Award 8 marks if students are able to provide a logical conclusion that clearly shows their stand of evaluating the factors that determines the health levels of a country.</i></p>

I agree to a large extent that investment and access to healthcare plays the most important role in determining the health levels of a country. Investment in healthcare refers to resources devoted by governments, businesses or individuals for the purposes of addressing the health and medical needs of a population. Health services refer to organisations and facilities to maintain and improve health. Hence, access to health services refers to the people's ability to obtain the services of these organisations. Investment in healthcare includes the money used to train and hire doctors and nurses, purchase medicine and medical equipment and investment in new drugs. The amount and quality of healthcare obtained depends on its accessibility, availability and affordability. For instance, DCs generally have a good level of healthcare with a high doctor-patient and bed-patient ratio. Singapore has 18 doctors and 31 hospital beds for every 10000 people in comparison to LDCs such as Bangladesh with only 3 doctors and 4 hospital beds for every 10000 people. Hence, investment and access to healthcare plays the most important role in determining the health levels of a country. This is especially evident in DCs and LDCs.

There are also other factors that determines the health levels of a country. Social factor is one of them. The level of education affects the health levels of a country. People who are educated are more likely to be informed on how to lead a healthy lifestyle. They also generally earn higher incomes that give them greater access to quality medical treatment, food and living conditions. In addition, children who receive formal schooling are more likely to learn about healthcare and nutrition. Of the 60.7 million primary school-age children who were out of school worldwide in 2012, 30.6 million of them were from Sub-Saharan Africa. In comparison to North America and Western Europe, only 1.3 million were out of school. This shows that there is lower access to education in LDCs as compared to DCs and this in turn will affect their level of awareness to make informed decisions about healthy diet and lifestyle, affecting the overall health levels of the population in the country.

Another factor is environmental factor. The access to safe drinking water for domestic purposes such as drinking, cooking and personal hygiene affects the level of health of a country. The lack of access to safe drinking water can cause the spread of waterborne diseases such as cholera and lead poisoning. Water that is not stored safely also encourages breeding grounds for mosquitoes which spread diseases. In 2010, 89% of the world's population have access to safe drinking water. 99% of them live in DCs while 86% of them live in LDCs. Hence, with the lack of access to safe drinking water, people will be easily affected by waterborne diseases.

In conclusion, I agree to a large extent that investment and access to healthcare plays the most important role in determining the health levels of a country. This is because investment and access to healthcare is necessary to prevent health from further deteriorating which can lead to deaths. While I acknowledge that there are other important factors that play a role in determining the health levels of a country such as environment and social factors, without investment and access to healthcare, health issues arising from social and environmental factors cannot be addressed.

-End of paper-



**BEDOK VIEW SECONDARY SCHOOL
PRELIMINARY EXAMINATION 2017**

CANDIDATE
NAME

REGISTER
NUMBER

CLASS

GEOGRAPHY
Secondary Four Express
Paper 2

2236/02
21 August 2017
1 hour 30 minutes

MARK SCHEME

Setter: Miss Hafizah

**FAIRFIELD METHODIST SCHOOL (SECONDARY)****PRELIMINARY EXAMINATION 2017
SECONDARY 4 EXPRESS****GEOGRAPHY
Paper 1****2236/01****Duration: 1 hour 40 minutes****Date: 17 August 2017**

READ THESE INSTRUCTIONS FIRST

Write your name, class and index number on the answer paper provided.
Write in dark blue or black pen on both sides of the paper.
You may use a soft pencil for any diagrams or rough working.
Do not use staples, paper clips, highlighters, glue or correction fluid.

Section A

Answer Question 1.

Section BAnswer one question.

Write all answers on the Answer paper provided.
Candidates should support their answers with the use of relevant examples.
Sketch maps and diagrams should be drawn whenever they serve to illustrate an answer.

At the end of the examination, fasten all your work securely together.
The number of marks is given in brackets [] at the end of each question or part question.

This question paper consists of 8 printed pages including the cover page.

Section A

This question is compulsory

- 1 The figure below shows the cross section of Rhinestone Coastal Dune Park. The park has not been doing well economically and in addition, it has had to execute a dune repair recently.

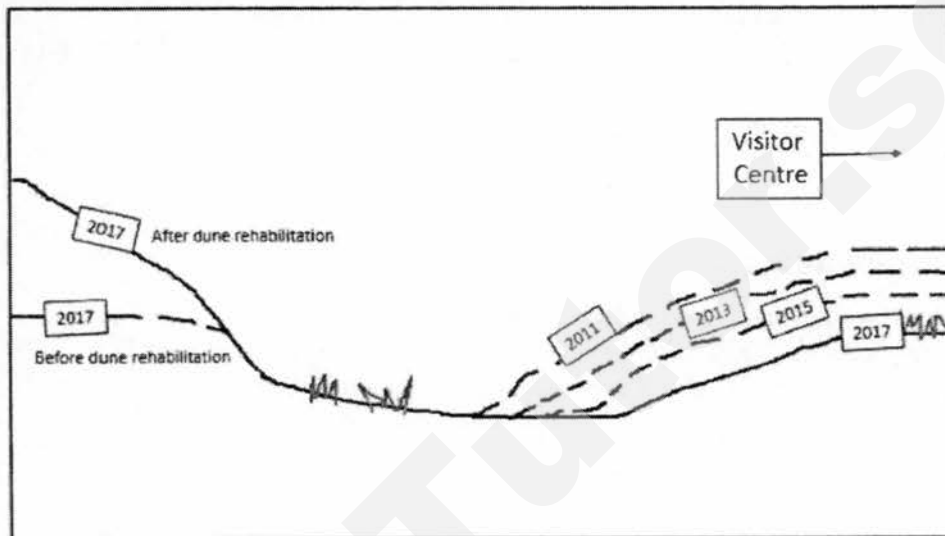

Fig. 1

- a) (i) As one of the measures implemented to boost visitor numbers to the dune park, the management wanted to introduce sand sledding. In order for that to take place, the angle of the dunes should not be too steep.

Describe how the management can go about to study whether the dune that has just been rehabilitated is suitable for sand sledding.

[6]

- (ii) What considerations do the managers have to take to ensure that the readings collected are accurate?

[2]

b)

	2011	2013	2015	2017
Dune that underwent repair (height in metres)	50	42	37	31
Dune that did not undergo repair (height in metres)	50	40	33	26

Table 1

With reference to Table 1, use a bar chart to represent the heights of the two dunes featured in Fig. 1, from 2011 to 2017.

[3]

- c) (i) Over the years, the management has also realised that the dune they repaired did not erode at as quick a rate as the other dune in their park. This difference can be observed in Fig. 1.

Suggest a hypothesis that describes the relationship between the rate of erosion of the sand dunes and the location of the dunes. [1]

- (ii) Explain the reason that led you to come up with this hypothesis. [2]

- d) A few years later, the management decides to re-implement the strategy in a). They then wanted investigate the effectiveness of the strategy and so they decided to carry out a bi-polar survey. The bi-polar survey was carried out on a Saturday afternoon and 50 dune park goers were asked to fill in the bi-polar survey. Fig. 2 shows a sample of the bi-polar survey used by the managers.

	-3	-2	-1	1	2	3	
Strategy is ineffective in preventing erosion.							Strategy is effective in preventing erosion.
Strategy is expensive to build.							Strategy is a cost-effective way of protecting the beach.
Strategy is unsightly.							Strategy does not detract from the scenic beauty of the beach.

Fig. 2

- (i) To carry out the survey, the students moved around in a large group at the same time. After carrying out the surveys in one section of the dune park, they then moved on to the next. Explain the advantage and disadvantage of conducting surveys in this manner. [2]
- (ii) Evaluate the criterion used in the bi-polar survey by commenting on the phrasing of the criterion. [2]
- (iii) Describe how the bi-polar survey should be carried out so the results can be more accurate. [5]
- (iv) Describe and explain where would be the most suitable location to conduct the bi polar survey so as to hit their target audience. [2]

Section B

Choose one question only

2. Study Fig. 3 which shows information about providing direct airline services to Kenya from different continents.

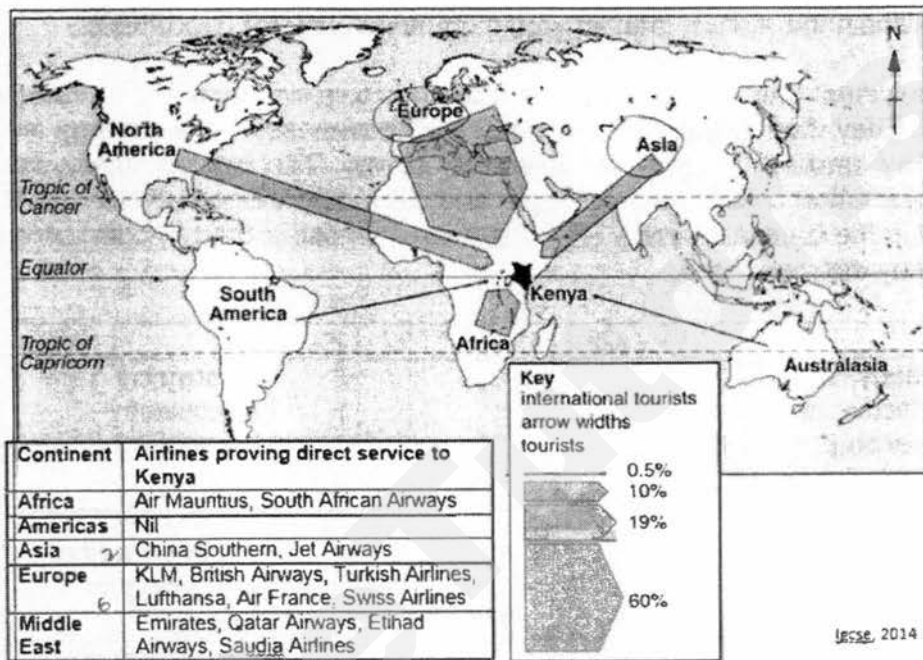

Fig. 3

- (a) With the help of Fig. 3, describe and explain the difference in tourist arrivals to Kenya from Europe and Asia.

[4]

(b) Fig. 4 shows tourist attractions in Hong Kong.

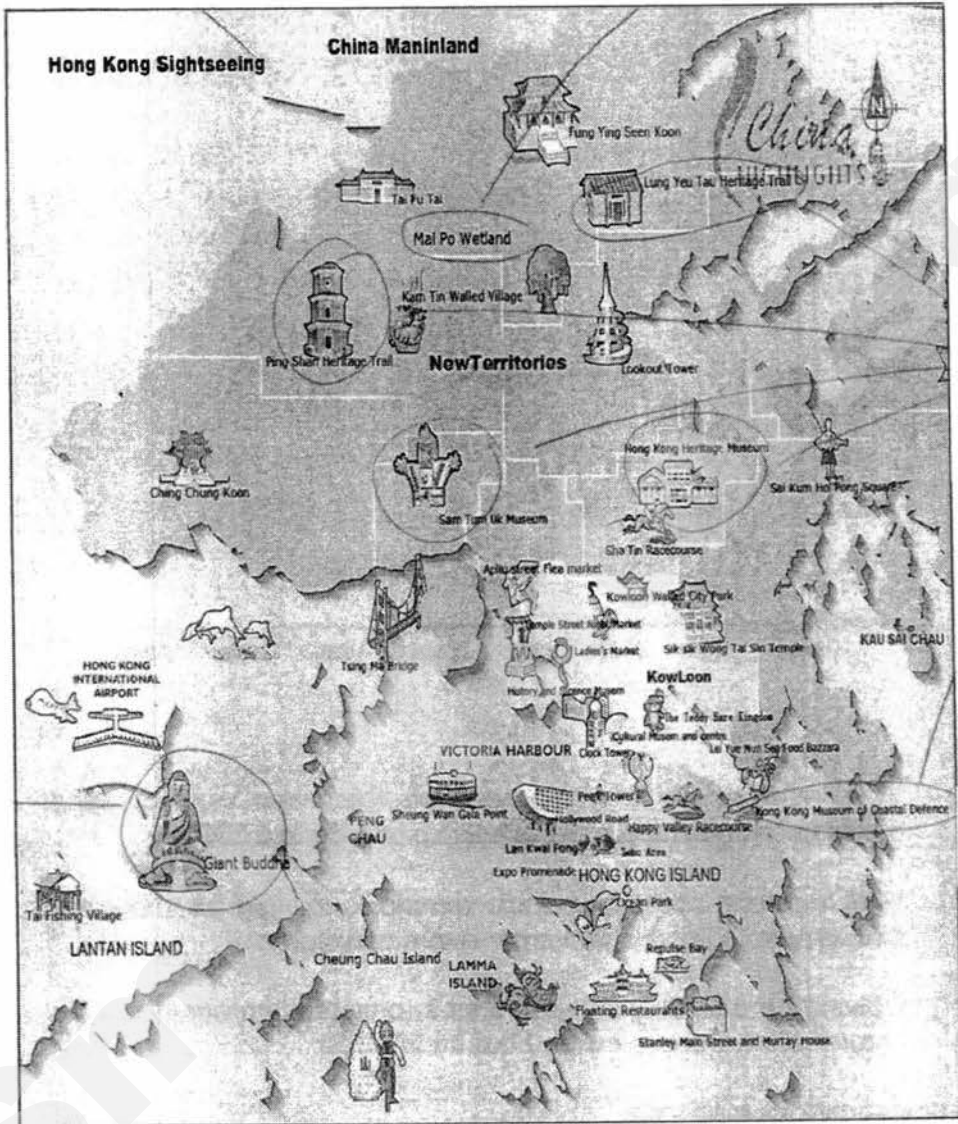

Fig. 4

With reference to Fig. 4, locate and explain 3 key tourist attractions that support the different types of tourism.

[4]

- (c) The graph below shows that the global average temperature of the earth.

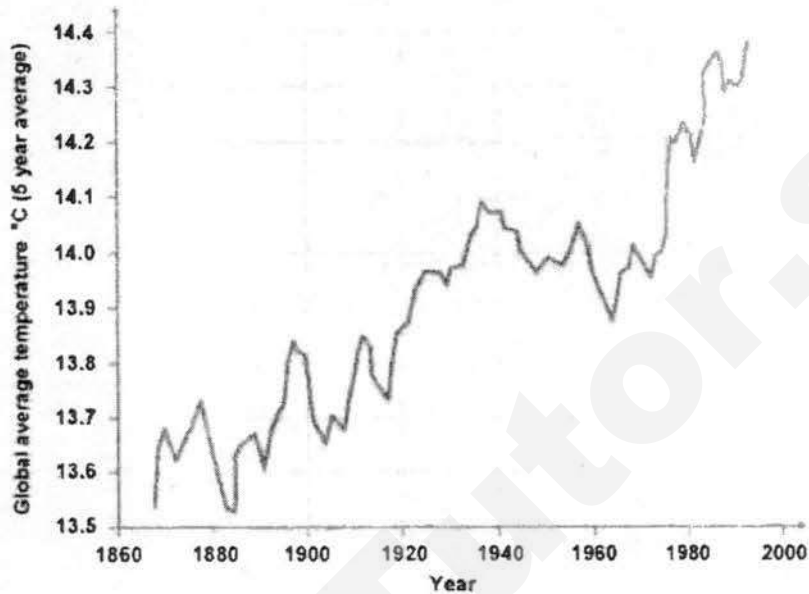

Fig. 5

- (i) With reference to Fig 5, describe the trend of the global average temperature of the earth from 1860 to 2000. [3]
- (ii) With reference to a specific example, explain how the trend observed in c(i) will affect coral reef ecosystems. [3]
- (iii) Describe the likely consequences to coastal communities if the coral reefs were to be wiped out by 2050. [3]
- (d) 'Tourism destroys tourism.'
- How far do you agree? Use examples to support your answer. [8]

3. Fig. 6 is an attraction of a natural landform found along the coast in Tasman National Park, Tasmania, Australia.



Fig. 6

- (a) (i) Describe the characteristics of the landform seen in Fig. 6. [2]
- (ii) Identify the natural landform and with the aid of a diagram, describe how it may have been formed over time. [5]
- (b) Explain how coastal areas can be managed in a sustainable manner. [3]

- (c) Fig. 7 below shows a coastal management strategy found at Hanasaki harbor in Japan.



Fig. 7

- (i) The coastal management strategy in Fig. 7 is actually a variation of one of the strategies you have learnt. Identify and describe what the strategy is. [2]
- (ii) With reference to examples you have learnt, describe and explain one instance of success and one limitation of the aforementioned strategy in (i). [2]
- (iii) Identify one other coastal management strategy which is constructed from the same material as the strategy in (i) and explain one instance of success and one limitation of the second strategy. [3]
- (d) 'The threats that mangroves face will overcome their abilities to adapt and survive in their saline coastal environments.'
- How far do you agree? Use examples to support your answer. [8]



FAIRFIELD METHODIST SCHOOL (SECONDARY)

PRELIMINARY EXAMINATION 2017 SECONDARY 4 EXPRESS

GEOGRAPHY
Paper 2

2236/02

Duration: 1 hour 30 minutes

Date: 22 Aug 2017

Additional Materials: Answer Paper
 1 Insert

READ THESE INSTRUCTIONS FIRST

Write your name, class and index number on the Answer Paper provided.
Write in dark blue or black pen on both sides of the paper.
You may use a soft pencil for any diagrams or graphs.
Do not use staples, paper clips, highlighters, glue or correction fluid.

Section A

Answer **one** question.

Section B

Answer **one** question.

Write all answers on the Answer Paper provided.
Candidates should support their answers with the use of relevant examples.
Sketch maps and diagrams should be drawn whenever they serve to illustrate an answer.
The Insert contains Fig. 2 for Question 1b, Fig. 4 for Question 2a, and Fig. 8 for Question 3a.

At the end of the examination, fasten all your work securely together.
The number of marks is given in brackets [] at the end of each question or part question.

This question paper consists of 9 printed pages including the cover page.

[Turn over

Name: _____ () Class: _____

Section A

Answer one question from this section.

- 1(a) With reference to Fig. 1, describe the distribution of subduction zones in the world. [4]

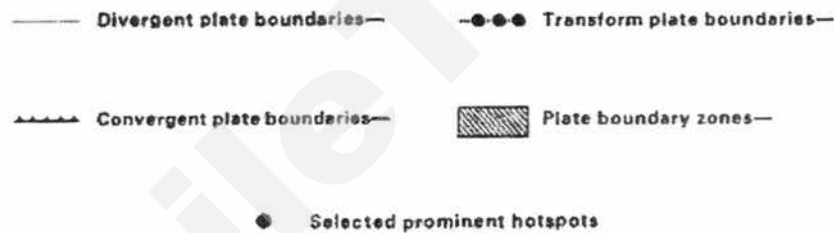
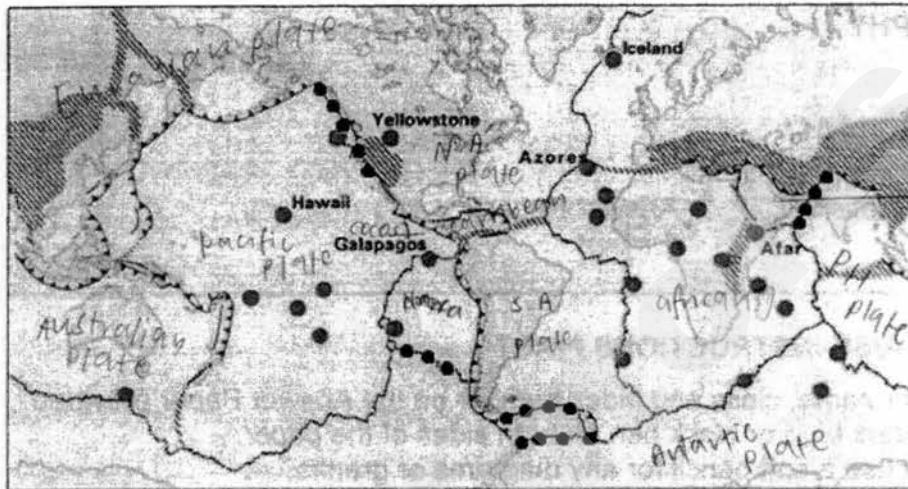

Fig. 1

- (b) Study Fig. 2 (Insert) which shows a tectonic landform found in Iceland.
- (i) Describe the characteristics of the landform found in Fig. 2. [2]
- (ii) With the aid of a well-labelled diagram, explain its formation. [4]

Name: _____ ()

Class: _____

- (c) Fig. 3 shows the internal structure of the earth.

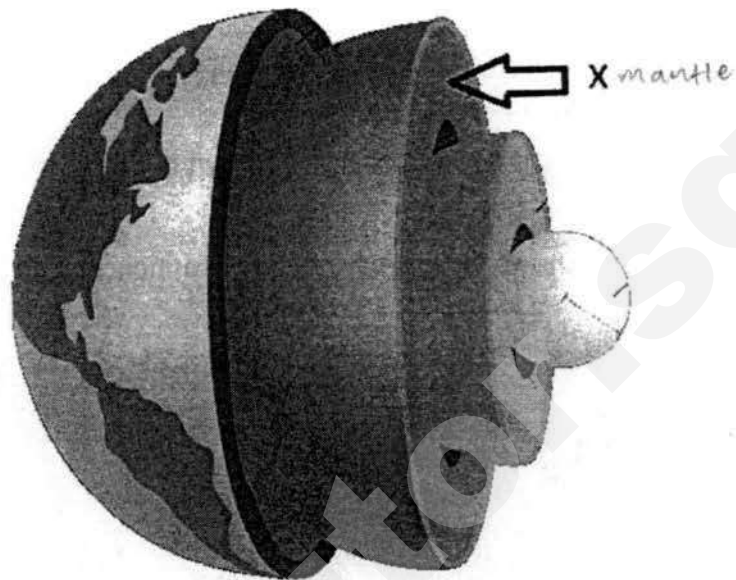

Fig. 3

- Identify Layer X and describe its physical characteristics. [3]
- (d) With the aid of examples, explain the advantage and disadvantage of a short term response in the event of an earthquake. [4]
- (e) 'Destruction of properties and infrastructure is the greatest hazard of earthquake in an inland city.'
- Do you agree? Support your answer with examples. [8]

Name: _____ () Class: _____

2(a) Fig. 4 (Insert) shows the number of catastrophic events in the world.

- (i) Describe the trend of the catastrophic events in the world between 1980 and 2012. [3]
- (ii) Suggest a reason for a trend shown in Fig. 4. [1]

(b) Figures 5 and 6 shows a volcano, Mount Kerinci, and its location in the world.

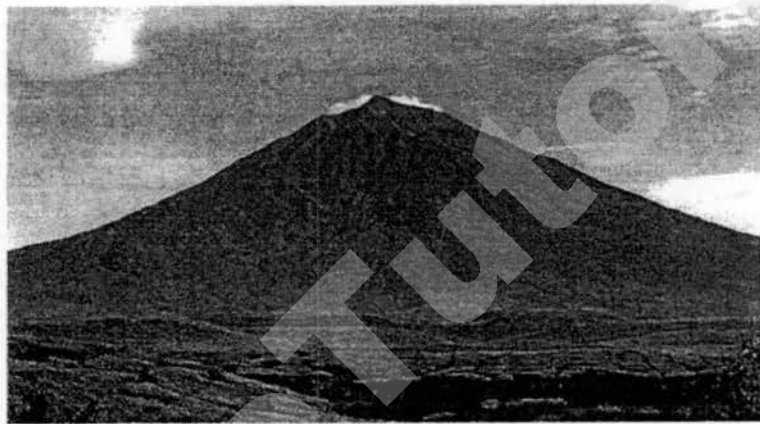

Fig. 5

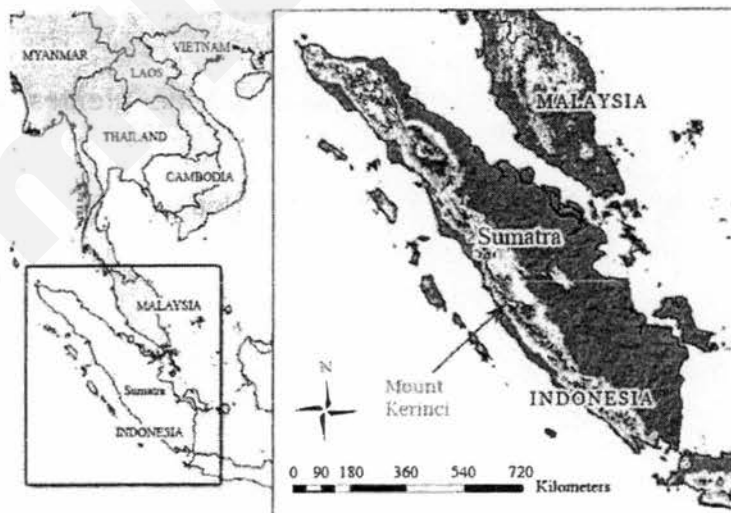

Fig. 6

- (i) Describe the characteristics of Mount Kerinci shown in Fig. 5. [2]
- (ii) With the aid of a well-labelled diagram, explain the formation of Mount Kerinci shown in Fig. 6. [4]

Name: _____ () Class: _____

- (c) Fig. 7 shows the Typhoon Haitang off the eastern coast of Taiwan in July 2005.

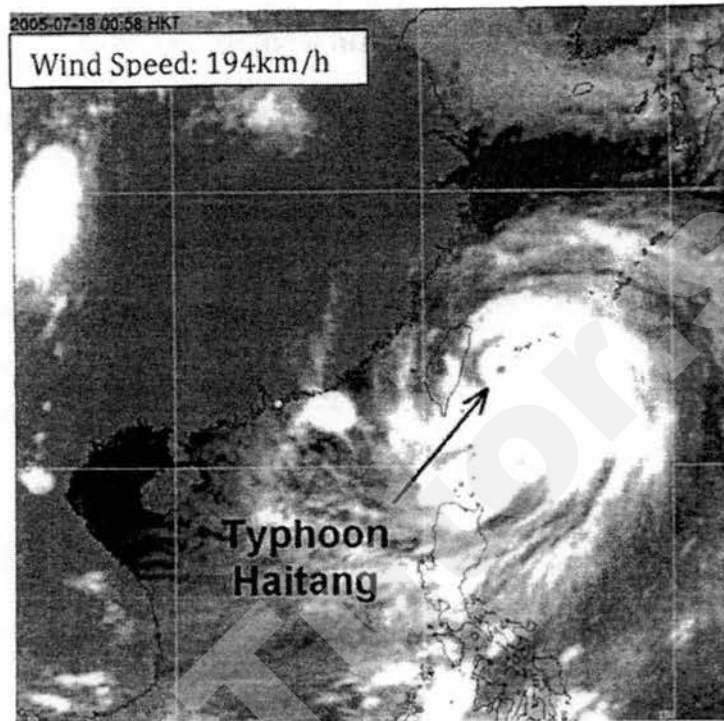

Fig. 7

Describe the characteristics of Typhoon Haitang. [3]

- (d) Explain the advantages and disadvantages of a strategy adopted by Singapore to fight climate change. [4]
- (e) 'Climate change is a greater concern for less developed countries than developed countries.'

Do you agree? Give reasons to support your answer. [8]

Name: _____ () Class: _____

Section B

Answer one question from this section.

- 3 (a) Fig. 8 (Insert) shows the future projection of water stress condition in agricultural lands all over the world in 2025.

Describe the pattern of the water stress condition across the globe. [4]

- (b) Fig. 9 shows the proportion of people who are hungry in developing countries and the percentage of children under five who are stunted.

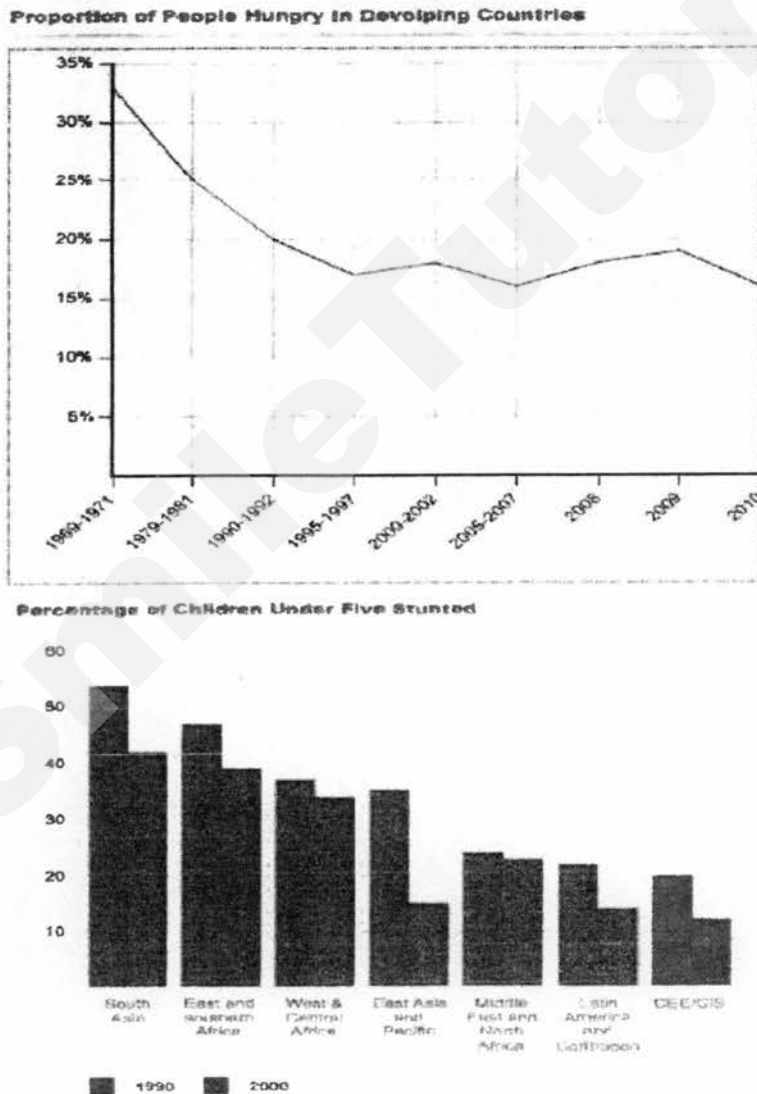

Fig. 9

Using Fig. 9, explain the political reason behind the trends. [5]

- (c) Fig. 10 is an abstract on the food security issue in Sudan.

Name: _____ ()

Class: _____

Nearly 4 million South Sudanese have been displaced from their homes since the country's internal conflict began in December 2013.

The latest IPC report, released this week, said armed conflict continues to disrupt agriculture and markets around the country, making food difficult to obtain.

Gottschalk said the onset of South Sudan's rainy season would make conditions worse by making roads impassable and bringing on waterborne diseases.

Fig. 10

Using Fig. 10 only, identify and explain the causes of food insecurity in Sudan. [4]

(d) With the aid of examples, explain why there is a high obesity rate in the developed countries. [4]

(e) 'The Green Revolution is more hazardous to the environment than Genetically-Modified Food'

Do you agree? Give reasons to support your answer. [8]

Name: _____ () Class: _____

4 (a) Fig. 11 shows the world's largest markets for organic products.

The World's Largest Markets For Organic Products

Organic retail sales value by country in 2013*

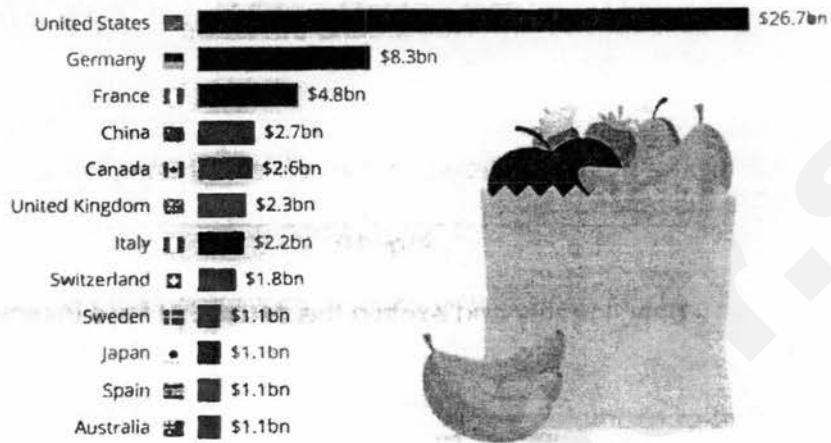

*Converted from EUR to USD on 23/07/15
Source: FiBL and IFOAM

statista

Fig. 11



Name: _____ () Class: _____

- (c) Fig. 13 shows a measure taken by the government to prevent the spread of malaria.



Fig. 13

- (i) Describe the preventive measure shown in Fig. 13. [1]
- (ii) With the aid of examples, evaluate a government mitigation measure against mosquito-borne diseases. [4]
- (d) Explain a social and economic factor that contribute to the spread of the HIV/AIDS epidemic. [4]
- (e) 'Education is the most important social factor in the difference of health between Developed Countries and Less Developed Countries.'
- Do you agree? Explain your answer. [8]

End-of-paper

Name: _____ () Class: _____



FAIRFIELD METHODIST SCHOOL (SECONDARY)

**PRELIMINARY EXAMINATION 2017
SECONDARY 4 EXPRESS**

**GEOGRAPHY
Paper 2**

2236/02

Duration: 1 hour 30 minutes

INSERT

READ THESE INSTRUCTIONS FIRST

This Insert contains Fig. 2 for Question 1b, Fig. 4 for Question 2a, and Fig. 8 for Question 3a.

This Insert consists of 3 printed pages including the cover page.

Name: _____ ()

Class: _____



Fig. 2

No. of catastrophic events in the world

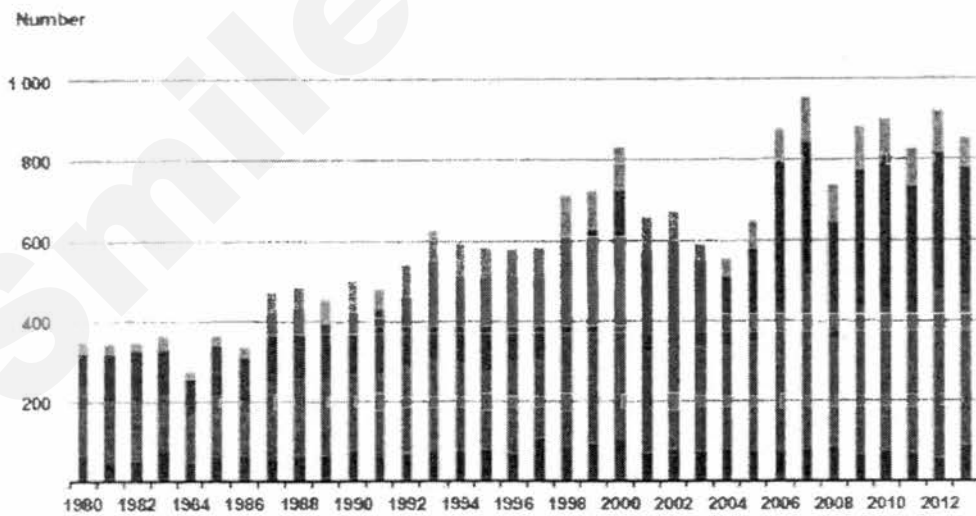

© 2014 Münchener Rückversicherungs-Gesellschaft, Geo Risks Research – As at January 2014

- Geophysical events (Earthquake, tsunami, volcanic eruption)
- Meteorological events (Tropical storm, extratropical storm, convective storm, local storm)
- Hydrological events (Flood, mass movement)
- Climatological events (Extreme temperature, drought, forest fire)

Fig. 4

Name: _____ () Class: _____

Water stress will increase in many agricultural areas by 2025 due to growing water use and higher temperatures (based on IPCC scenario A1B)

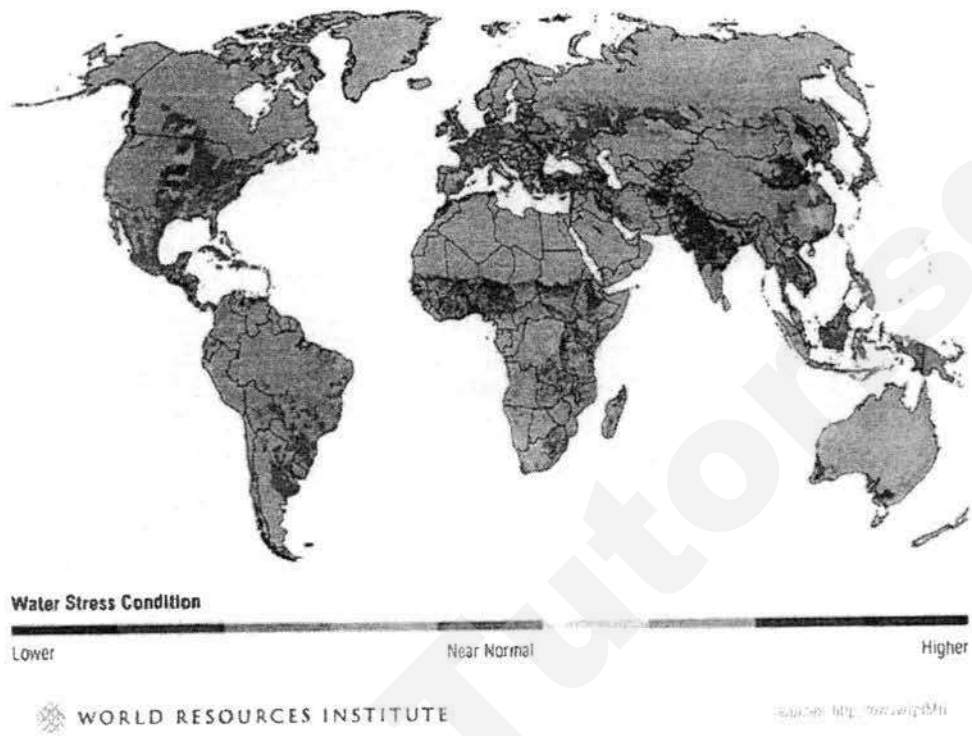

Fig. 8

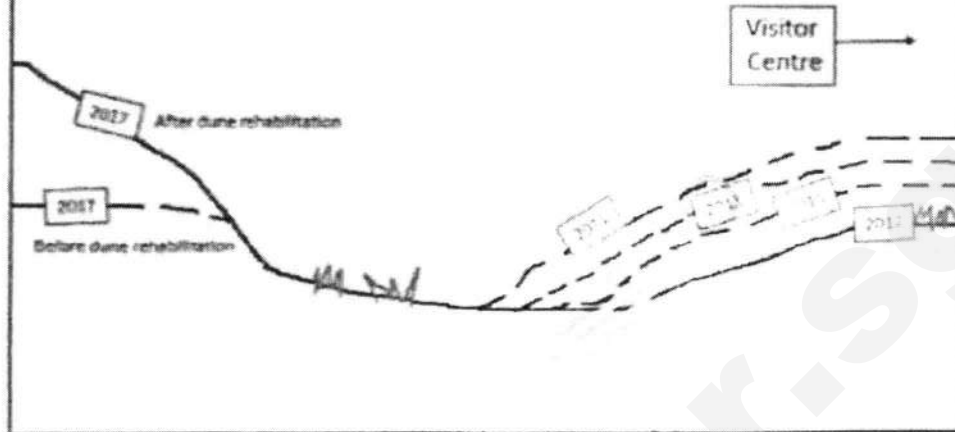

Fig. 1

- a) (i) As one of the measures implemented to boost visitor numbers to the dune park, the management wanted to introduce sand sledding. In order for that to take place, the angle of the dunes should not be too steep.

Describe how the management can go about to study whether the dune that has just been rehabilitated is suitable for sand sledding.

[6]

- Lay out the measuring tape along the line of the transect, starting from the base of the slope to the peak
- Mark out equidistant points along the transect where there is a distinct change in the gradient of the dune slope.
- Place the first ranging pole at the base of the dune and the second at the first change in gradient.
- Use a clinometer to measure the dune slope by placing it on the top of the first ranging pole and aiming it to the top of the second ranging pole
- Record the gradient value along with the distance between the poles.

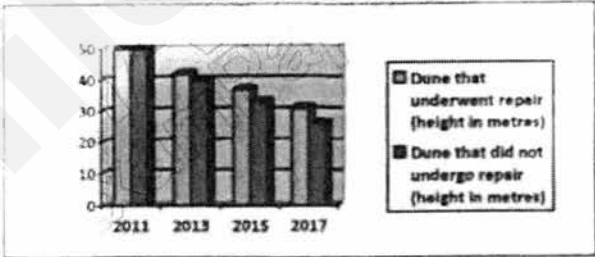
	<ul style="list-style-type: none"> • Move the first pole to the next change of beach slope and measure the angle of the slope and distance between poles and continue for all changes in dune slopes. <p>Award 1m for each valid point.</p>																
	(ii) What considerations do the managers have to take to ensure that the readings collected are accurate?	[2]															
	<ul style="list-style-type: none"> • Make sure both poles are the same height and do not push poles into the sand • Hold poles upright. • Take the average of 3 readings at least for each point <p>Award 1m for each valid point.</p>																
b)	<table border="1"> <thead> <tr> <th></th> <th>2011</th> <th>2013</th> <th>2015</th> <th>2017</th> </tr> </thead> <tbody> <tr> <td>Dune that underwent repair (height in metres)</td> <td>50</td> <td>42</td> <td>37</td> <td>31</td> </tr> <tr> <td>Dune that did not undergo repair (height in metres)</td> <td>50</td> <td>40</td> <td>33</td> <td>26</td> </tr> </tbody> </table> <p style="text-align: center;">Table 1</p>		2011	2013	2015	2017	Dune that underwent repair (height in metres)	50	42	37	31	Dune that did not undergo repair (height in metres)	50	40	33	26	
	2011	2013	2015	2017													
Dune that underwent repair (height in metres)	50	42	37	31													
Dune that did not undergo repair (height in metres)	50	40	33	26													
	With reference to Table 1, use a bar chart to represent the heights of the two dunes featured in Fig. 1, from 2011 to 2017	[3]															
	<p style="text-align: center;">The heights of the two dunes</p> 																
c)	<p>(i) Over the years, the management has also realised that the dune they rehabilitated did not erode at as quick a rate as the other dune in their park. This difference can be observed in Fig. 1.</p> <p>Suggest a hypothesis that describes the relationship between the rate of erosion of the sand dunes and the location of the dunes.</p>	[1]															
	<p>The further away from the visitor centre, the slower the rate of erosion./ The nearer to the the visitor centre, the faster the rate of erosion.</p> <p>Award 1m for each valid point.</p>																

	<p>(ii) Explain the reason that led you to come up with this hypothesis.</p> <p>The visitors enter the dune park from the visitor centre side and most visitors will pass by the dune on that side.</p> <p>Not all visitors will make it to the other dune and hence, the fewer visitors there are, the less treading on the sand dunes there will be and this reduces the rate of erosion.</p> <p>Award 1m for each valid point.</p>	[2]																																
d)	<p>A few years later, the management decides to implement the strategy in a). They then wanted investigate the effectiveness of the strategy and so they decided to carry out a bi-polar survey. The bi-polar survey was carried out on a Saturday afternoon and 50 dune park goers were asked to fill in the bi-polar survey. Fig. 2 shows a sample of the bi-polar survey used by the managers.</p>																																	
	<table border="1" style="width: 100%; border-collapse: collapse;"> <thead> <tr> <th style="width: 25%;"></th> <th style="width: 7.5%;">-3</th> <th style="width: 7.5%;">-2</th> <th style="width: 7.5%;">-1</th> <th style="width: 7.5%;">1</th> <th style="width: 7.5%;">2</th> <th style="width: 7.5%;">3</th> <th style="width: 25%;"></th> </tr> </thead> <tbody> <tr> <td>Strategy is ineffective in preventing erosion.</td> <td></td> <td></td> <td></td> <td></td> <td></td> <td></td> <td>Strategy is effective in preventing erosion.</td> </tr> <tr> <td>Strategy is expensive to build.</td> <td></td> <td></td> <td></td> <td></td> <td></td> <td></td> <td>Strategy is a cost-effective way of protecting the beach.</td> </tr> <tr> <td>Strategy is unsightly.</td> <td></td> <td></td> <td></td> <td></td> <td></td> <td></td> <td>Strategy does not detract from the scenic beauty of the beach.</td> </tr> </tbody> </table> <p style="text-align: center;">Fig. 2</p>		-3	-2	-1	1	2	3		Strategy is ineffective in preventing erosion.							Strategy is effective in preventing erosion.	Strategy is expensive to build.							Strategy is a cost-effective way of protecting the beach.	Strategy is unsightly.							Strategy does not detract from the scenic beauty of the beach.	
	-3	-2	-1	1	2	3																												
Strategy is ineffective in preventing erosion.							Strategy is effective in preventing erosion.																											
Strategy is expensive to build.							Strategy is a cost-effective way of protecting the beach.																											
Strategy is unsightly.							Strategy does not detract from the scenic beauty of the beach.																											
	<p>(i) To carry out the survey, the students moved around in a large group at the same time. After carrying out the surveys in one section of the dune park, they then moved on to the next. Explain the advantage and disadvantage of conducting surveys in this manner.</p>	[2]																																
	<p><u>Advantages:</u></p> <ul style="list-style-type: none"> • One advantage of conducting surveys in this manner is efficiency – the students should be able to work together and get the surveys done more quickly. • One advantage of conducting surveys in this manner is they can get a large sample at one location – if a large sample size is required, the students can get more responses since all the students are there at the same time to conduct the surveys <p><u>Disadvantages:</u></p> <ul style="list-style-type: none"> • However, there will likely be errors because the surveys at different 																																	

	<p>locations would be carried out at different times of the day</p> <ul style="list-style-type: none"> • It might be more efficient for the students to split up rather than stick together in a group • Also, if there are too many students and too few tourists, they will likely be some researchers with nothing to do. <p>Award 1m for each valid point.</p>	
	(ii) Evaluate the criterion used in the bi-polar survey by commenting on the phrasing of the criterion.	[2]
	<ul style="list-style-type: none"> • Beach goers would not be able to assess if the strategy is effective or not as they have no technical knowledge. • They also would not know the cost of the strategy. <p>Award 1m for each valid point.</p>	
	(iii) Describe how the bi-polar survey should be carried out so the results can be more accurate.	[5]
	<ul style="list-style-type: none"> • Come up with a range which is from -3 to 3. • Write in a table and come up with a list of criteria. • Criteria should not be vague or open to interpretation. If possible, standardise the criteria by taking picture of what you mean. For example, -1 represents a fixed quantity so that both respondents and investigator have the same idea. • Example of the list of criteria include pollution, noise, litter, cost, effectiveness and human traffic • Choose a sampling method (either random or systematic) and survey 30 to 50 people. • Record the responses and a plot out a bipolar graph to analyse your survey results. <p>Award 1m for each valid point.</p>	
	(iv) Describe and explain where would be the most suitable location to conduct the bi polar survey so as to hit their target audience.	[2]
	<ul style="list-style-type: none"> • The exit of the sand dune park would be a suitable location • This is where the highest human traffic will pass by so that the students can catch visitors just before they leave and will also be able to talk to those who have actually visited the dune park <p>Award 1m for each valid point</p>	

Section B

Choose one question only.

2. Study Fig. 3 which shows information about providing direct service to Kenya from different continents.

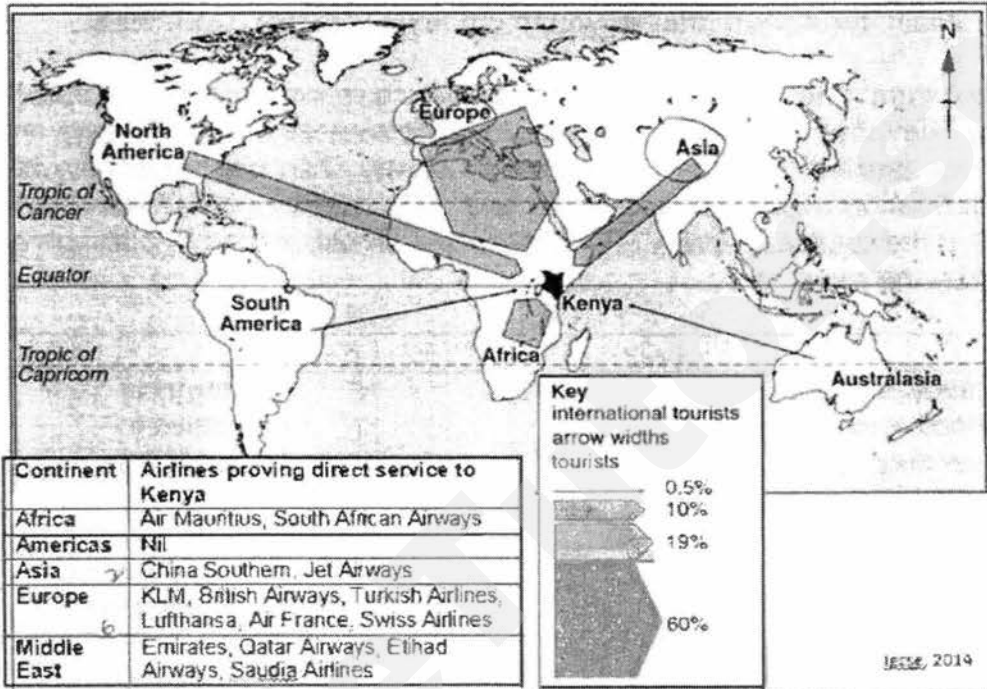

Fig. 3

(a) With the help of Fig. 3, describe and explain the difference in tourist arrivals to Kenya from Europe and Asia. [5]

- European tourists are 6 times [60%] more than Asian tourists [10%]
- Proximity: Europe is closer to Kenya than most of Asia – so more time needed to travel to Kenya for Asians, which would be a discouraging factor for going there.
- Europe is closer to Kenya than most of Asia and so the cost of traveling there will be lower as well
- There are 6 airlines connecting Europe to Kenya while only 2 for Asia.
- This decreases connectivity/accessibility and increases cost [due to non-competition] for Asia. Hence, fewer Asians travel to Kenya.
- The language proficiency(English) of European tourists is higher as compared to Asian tourists and more similar to that in Kenya

Award 1m for each valid point.

(b) Fig. 4 shows the tourist attractions in Hong Kong.

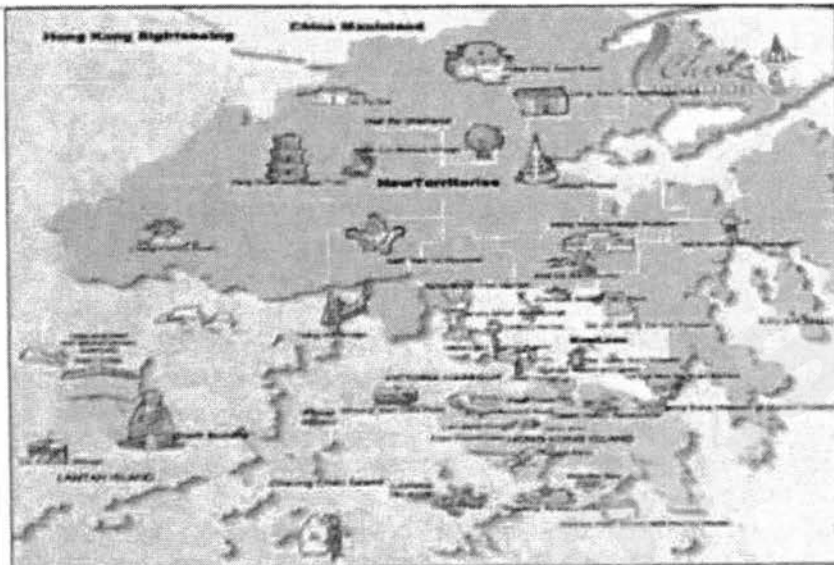



Fig. 4

With reference to Fig. 4, locate and explain 3 key tourist attractions that support the different types of tourism.

[3]

- Giant Buddha: Tourists visit to learn more about Buddhism or Culture (Pilgrimage tourism/ cultural tourism).
- Ocean Park/ Teddy Bear Kingdom: Theme park where tourists visit for recreation activities
- Temple Street Night Market/ Ladies Market: Tourists visit for shopping purposes
- Expo Promenade. MICE where tourists visit for exhibitions for conventions
- Hong Kong Heritage Museum: tourists visit to know more about the history or culture of Hong Kong
- Lookout Tower: tourists visit to look at the scenic beauty of Hong Kong

Award 1m for each valid point.

(c)	<p>The graph below shows that the global average temperature of the earth.</p>  <p style="text-align: center;">Fig. 5</p>	
	(i) With reference to Fig 5, describe the trend of the global average temperature of the earth from 1860 to 2000.	[3]
	<ul style="list-style-type: none"> • Fluctuating but overall, increasing trend from 13.5°C to 14.4 °C • Largest increase : 0.35 (1919-1939)/ largest decrease: 0.25 (1879-1881) • 1960 onwards: The Temperature increased at a faster rate <p><i>Award 1m for each valid point</i></p>	
	<p>(ii) With Reference to a specific example, explain how the trend observed in c(i) will affect coral reef ecosystems.</p> <ul style="list-style-type: none"> • Rapid changes in sea temperatures and sea levels may be faster than the ability of the reefs and their associated life forms to adjust • Coral bleaching occurs when higher sea temperatures result in the loss of algae; this causes the coral to turn completely white or be bleached • Preliminary results of a survey in May this year found all the reefs looked at in the Maldives, in the Indian Ocean, were affected by high sea surface temperatures. Around 60% of all assessed coral colonies, and up to 90% in some areas, were bleached. <p><i>Award 1m for each valid point.</i></p>	[3]



(iii)	Describe the likely consequences to coastal communities if the coral reefs were to be wiped out by 2050.	[3]				
<ul style="list-style-type: none"> • Livelihood: Corals play a crucial role in supporting natural ecosystems i.e. more than 25 per cent of the earth's marine fish species. Fisheries contribute to GDP e.g Bahamas , Fiji • More prone to disaster and loss of land as corals absorb wave energy generated in the open seas by protecting the adjacent land mass from erosion e.g. Bahamas, Maldives • Less natural resources: Corals provide medicine for some major diseases like cancer and HIV e.g. Indonesia, Bahamas, Fiji <p>Award 1m for each valid point.</p>						
(d)	'Tourism destroys tourism.'	[8]				
<p>How far do you agree? Use examples to support your answer.</p> <p>Tourism destroy tourism - negative impacts of tourism BUT tourism also helps/boost tourism - positive impacts of tourism</p> <p>Impacts OF tourism ON Tourism Need to link back to question and talk about the impacts on tourism itself</p> <p>Need to explain how tourism leads to the point/ factor and then how the point/ factor affects tourism</p>						
<table border="1" style="width: 100%;"> <thead> <tr> <th style="width: 50%;">Does not destroy</th> <th style="width: 50%;">Destroy</th> </tr> </thead> <tbody> <tr> <td style="vertical-align: top;"> <p>Employment opportunities</p> <ul style="list-style-type: none"> o Growth of tourism lead to increase in the number of tourism related jobs, offering many employment opportunities either directly linked or indirectly linked to the tourism sector, such as hotels, transportation, tour agencies. o In 2011, the tourism industry employed over 235 million people worldwide (6-8 % of all the jobs in the world) o Thus people are able to earn an income (often higher income) and as such, they have more purchasing power </td> <td style="vertical-align: top;"> <p>Leakage of Income</p> <ul style="list-style-type: none"> o A Large portion of revenue from tourism is sometimes lost as leakage, especially in LDCs. o Leakage occurs when revenue earned from tourism is paid to other countries for the import of goods and services needed to meet the needs of tourists o Thus, the country will earn less income and as such, they have less money for developing the tourism infrastructures and attractions in their country, causing future tourism to fail. </td> </tr> </tbody> </table>			Does not destroy	Destroy	<p>Employment opportunities</p> <ul style="list-style-type: none"> o Growth of tourism lead to increase in the number of tourism related jobs, offering many employment opportunities either directly linked or indirectly linked to the tourism sector, such as hotels, transportation, tour agencies. o In 2011, the tourism industry employed over 235 million people worldwide (6-8 % of all the jobs in the world) o Thus people are able to earn an income (often higher income) and as such, they have more purchasing power 	<p>Leakage of Income</p> <ul style="list-style-type: none"> o A Large portion of revenue from tourism is sometimes lost as leakage, especially in LDCs. o Leakage occurs when revenue earned from tourism is paid to other countries for the import of goods and services needed to meet the needs of tourists o Thus, the country will earn less income and as such, they have less money for developing the tourism infrastructures and attractions in their country, causing future tourism to fail.
Does not destroy	Destroy					
<p>Employment opportunities</p> <ul style="list-style-type: none"> o Growth of tourism lead to increase in the number of tourism related jobs, offering many employment opportunities either directly linked or indirectly linked to the tourism sector, such as hotels, transportation, tour agencies. o In 2011, the tourism industry employed over 235 million people worldwide (6-8 % of all the jobs in the world) o Thus people are able to earn an income (often higher income) and as such, they have more purchasing power 	<p>Leakage of Income</p> <ul style="list-style-type: none"> o A Large portion of revenue from tourism is sometimes lost as leakage, especially in LDCs. o Leakage occurs when revenue earned from tourism is paid to other countries for the import of goods and services needed to meet the needs of tourists o Thus, the country will earn less income and as such, they have less money for developing the tourism infrastructures and attractions in their country, causing future tourism to fail. 					

	<p>to travel in future, causing future tourism to rise.</p>	<p>Example: Phuket, Thailand Travellers may use the services of foreign-owned businesses and buy imported items</p> <ul style="list-style-type: none"> ▪ Some of the profits made by local businesses are sent to another country to pay for imports ▪ Money that does not stay in the local economy may bring few benefits to local businesses and workers 	
	<p>Infrastructure development</p> <ul style="list-style-type: none"> ○ Infrastructure development such as transport and communication networks serve the local communities as they enhance tourism, such as roads linking airports to the city and other tourist sites. Sports venues and infrastructure built for major sporting events like the Olympics are useful to the host country even after the event. ○ The development of roads and expansion of airport (due to growth in tourism), this will further aid in the boost of future tourism as the country is more accessible and it has enough capacity to hold a higher number of visitors. As such more visitors will be willing to travel to the country, increasing future tourism. ○ Developing the infrastructure also create employment for local workers especially during the construction process. Thus they earn an income (often higher income) and as such, they have more purchasing power to travel in future, causing future tourism to rise. 	<p>Underuse of facilities</p> <ul style="list-style-type: none"> ○ Money from tourists normally pays for the cost of maintaining such facilities ○ Underused facilities can be costly to maintain ○ Facilities may become neglected when there are few tourists. ○ As the facilities are poorly or not maintained, tourists will not want to visit, causing tourism to fall further and for the facilities to continue to remain neglected. ○ example: Venue for Summer Olympic Games In Beijing <ul style="list-style-type: none"> ▪ Venues allegedly deteriorating years after the Olympics ▪ Some were renovated to become more profitable, ▪ e.g. Beijing National Aquatics Center was renovated into a water park ▪ Only one-third of major sports venues in China have managed to break even ○ Shortage of services <ul style="list-style-type: none"> ▪ Tourist infrastructure may require the use of large amounts of land, water and power ▪ This could lead to a shortage of services, e.g. water supplies or power in non- 	

		tourist areas						
<p>Growth in income</p> <ul style="list-style-type: none"> o Tourism growth can lead to growth in income for individuals and a country o As a result, they have more purchasing power to travel in future, causing future tourism to rise. o Or, country has more revenue, thus more money to invest in tourism infrastructures and facilities, as a result, attracting more tourists in future. <p>Example: Fishermen on Pamilacan Island, Philippines</p> <ul style="list-style-type: none"> • Local tour companies hire fishermen to help them view and swim with whale sharks • Fishermen are paid between US\$80–US\$100 per boat for their service • Fishermen can expect additional income on top of their fishing livelihood. • Tour companies will experience an increase in revenue • Overall increase in revenue for the country through taxes collected from the fishermen and tour companies <p>Tourism receipts generate large revenue for many countries</p> <ul style="list-style-type: none"> • In 2011, worldwide tourism receipts exceeded US\$1 trillion 	<p>Seasonal unemployment</p> <ul style="list-style-type: none"> o Certain tourist activities depend on climatic conditions o Countries may experience regular fluctuations in tourist numbers o People in tourism-related jobs have to find other sources of income when employment is temporarily unavailable o Thus income is not stable, they will be more unwilling to travel, causing a decline in tourism <p>Example: Sapporo, Japan</p> <ul style="list-style-type: none"> • Receives a large number of visitors from December to February, many of whom engage in winter sports, e.g. skiing, snowboarding • Mountain ski resort operators employ more people during winter to cater to the high tourist demand • In other reasons, workers return to other jobs, (e.g. farming) or move away temporarily until the next tourist season 							
<p>Accept any other positive/Negative impacts listed : Environmental and Sociocultural</p>								
<table border="1"> <thead> <tr> <th>Level 1 (0-3m)</th> <th>Level 2 (4-6m)</th> <th>Level 3 (7-8m)</th> </tr> </thead> <tbody> <tr> <td>Brief explanation of factors</td> <td>Somewhat detailed explanation of at least 2 factors</td> <td>Very Detailed explanation of at least 3 factors</td> </tr> </tbody> </table>	Level 1 (0-3m)	Level 2 (4-6m)	Level 3 (7-8m)	Brief explanation of factors	Somewhat detailed explanation of at least 2 factors	Very Detailed explanation of at least 3 factors		
Level 1 (0-3m)	Level 2 (4-6m)	Level 3 (7-8m)						
Brief explanation of factors	Somewhat detailed explanation of at least 2 factors	Very Detailed explanation of at least 3 factors						

<p>Discuss either only benefits or limitations</p> <p>No examples are used to support factor</p>	<p>Discuss some benefits and/or limitations</p> <p>Includes only 1 category of factor (E.g. economic)</p> <p>Supported with general examples</p>	<p>Discuss both benefits and limitations</p> <p>AND</p> <p>Includes min 2 categories of factor (E.g. economic/social/environmental)</p> <p>Supported with specific examples</p>
--	--	---

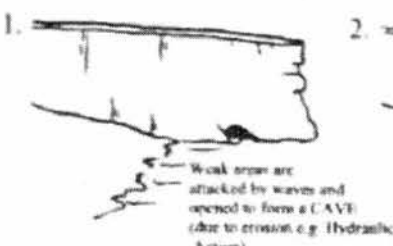
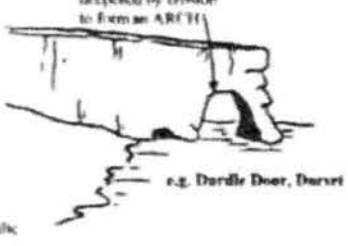
3.	Fig. 6 is an attraction of a natural landform found along the coast in Tasman National Park, Tasmania, Australia.	
	 <p style="text-align: center;">Fig. 6</p>	
(a)	(i) Describe the characteristics of the landform seen in Fig. 6.	[2]
	<ul style="list-style-type: none"> • Curved at the top • Supported by two sides but gap in the center where the sea is below • Jagged/ Rough Edges • Vegetation on the top <p>Award 1m for each valid point</p>	
	(ii) Identify the natural landform and with aid of a diagram, describe how it may have been formed over time.	[5]
	<ul style="list-style-type: none"> • Arch <p>Reserve 1m for identification of landform.</p> <ul style="list-style-type: none"> • Destructive waves erode both sides of the base of a headland; • by hydraulic action and abrasion; • undercutting it to form a cave; • wave action causes hollowing of a cave as the back walls join together; 	

	<p style="text-align: center;">EROSION OF A HEADLAND</p> <div style="display: flex; justify-content: space-around;"> <div style="text-align: center;"> <p>1.</p>  </div> <div style="text-align: center;"> <p>2.</p>  </div> </div> <p>Award 1m for each valid point. Maximum 4 marks. If no accompanying diagram is drawn, max of 3 marks.</p>	
(b)	<p>Explain how coastal areas can be managed in a sustainable manner.</p>	[3]
	<ul style="list-style-type: none"> • Limiting damaging activities that interrupt the functioning of natural systems. • These activities may include clearing mangroves for fish farms or agricultural land, dumping waste into coastal areas and construction facilities for ports or hotels which place the natural features at the coast. • Protect Coastal Resources by preventing resources from being exploited or depleted • This can be achieved by limiting the area where people can obtain that resource or limit the amount of the resource that can be extracted. <p>Award 1m for each valid point.</p>	
(c)	<p>Fig. 7 below shows a coastal management strategy found at Hanasaki harbor in Japan.</p>	
	 <p>Fig. 7</p>	

	(i) The coastal management strategy in Fig. 7 is actually a variation of one of the strategies you have learnt. Identify and describe what the strategy is.	[3]
	<ul style="list-style-type: none"> • Tetrapod • Concrete structures that help to dissipate wave energy • Tetrapods allow water to pass around them rather than hit against them so no powerful backwash is generated, which reduces the possibility of tetrapods being damaged by waves. <p>Award 1m for each valid point.</p>	
	(ii) With reference to examples you have learnt, describe and explain one instance of success and one limitation of the aforementioned strategy in (i).	[2]
	<ul style="list-style-type: none"> • Crescent City, a town on the coast of northern California, has used tetrapods for many years to defend against coastal erosion and to reduce the impact of tsunamis, which occurred 31 times between 1933 and 2008. • Okinawa, Japan: People living there find it an eyesore as the pristine beaches and unaltered shoreline have been ruined by the presences of tetrapods, especially in the Southern half of the island. <p>Award 1m for each valid point.</p>	
	(iii) Identify one other coastal management strategy which is constructed from the same material as the strategy in (i) and explain one instance of success and one limitation of the second strategy .	[3]
	<ul style="list-style-type: none"> • Seawalls are constructed to protect coastlines against wave attack by absorbing wave energy. Most seawalls are made of concrete or stone and are built parallel to the coast. They have been constructed in thousands of locations throughout the world. • East Coast Park, Singapore: Initially, a 4,500-metre stretch of seawall was built to protect the reclaimed land. A strip of fill made of old alluvium was left in front of the seawall to allow deposition to occur, forming beaches. • Drakes Island, England: A seawall collapsed due to erosion occurring at its base. <p>OR</p> <ul style="list-style-type: none"> • Breakwaters help break the force of oncoming waves. They can be built either parallel to the coast or with one end 	

	<p>attached to the coast. When constructed offshore, breakwaters can create a zone of calm water behind them. Materials are then deposited and build up in this zone of calm water to form beaches.</p> <ul style="list-style-type: none"> Almeria, Spain: Breakwaters successfully protected the coast from erosion. Portland Harbour, England: The breakwaters built resulted in erosion and flooding which affected properties, beaches and communication infrastructure. <p>Also accept Groynes if students write.</p> <p>Award 1m for each valid point.</p>							
(d)	<p>'The threats that mangroves face will overcome their abilities to adapt and survive in their saline coastal environments'</p> <p>How far do you agree? Use examples to support your answer.</p>	[8]						
	<table border="1" style="width: 100%; border-collapse: collapse;"> <thead> <tr> <th style="width: 50%; text-align: left;">Will overcome</th> <th style="width: 50%; text-align: left;">Ability to adapt and survive</th> </tr> </thead> <tbody> <tr> <td style="vertical-align: top;"> <p>Water pollution Peru: Urban and manufacturing activities result in untreated or partly treated urban and manufacturing wastes being dumped into coastal waters. The pollution of coastal waters can overwhelm the delicate balances of mangrove ecosystems.</p> </td> <td style="vertical-align: top;"> <p>Filter pollutants → Ultra Filtrators (ROOTS): Burguiera. Sonneratia and Rhizophora. Also store salt in their leaves so they can be shed.</p> </td> </tr> <tr> <td style="vertical-align: top;"> <p>Rising sea level Gulf of Thailand: Rising sea levels, together with extreme storm activity, is likely to occur in future if climate change accelerates. Mangroves will have trouble colonising areas further inland despite sea level rise as they will be in competition with human activities such as farming and the construction of sea defences.</p> </td> <td style="vertical-align: top;"> <p>High Intensity full sunlight (tropical zones) → Leaves of mangroves thick and leathery to withstand heat</p> <p>Annual rainfall (1500 - 3000 mm) → Leaves of mangroves waxy with drip tips to allow excess water to drip off</p> <p>They are typically found along low-lying coasts and river estuaries, in anaerobic (oxygen poor) soils. Roots of mangrove (Rhizophora)</p> </td> </tr> </tbody> </table>	Will overcome	Ability to adapt and survive	<p>Water pollution Peru: Urban and manufacturing activities result in untreated or partly treated urban and manufacturing wastes being dumped into coastal waters. The pollution of coastal waters can overwhelm the delicate balances of mangrove ecosystems.</p>	<p>Filter pollutants → Ultra Filtrators (ROOTS): Burguiera. Sonneratia and Rhizophora. Also store salt in their leaves so they can be shed.</p>	<p>Rising sea level Gulf of Thailand: Rising sea levels, together with extreme storm activity, is likely to occur in future if climate change accelerates. Mangroves will have trouble colonising areas further inland despite sea level rise as they will be in competition with human activities such as farming and the construction of sea defences.</p>	<p>High Intensity full sunlight (tropical zones) → Leaves of mangroves thick and leathery to withstand heat</p> <p>Annual rainfall (1500 - 3000 mm) → Leaves of mangroves waxy with drip tips to allow excess water to drip off</p> <p>They are typically found along low-lying coasts and river estuaries, in anaerobic (oxygen poor) soils. Roots of mangrove (Rhizophora)</p>	
Will overcome	Ability to adapt and survive							
<p>Water pollution Peru: Urban and manufacturing activities result in untreated or partly treated urban and manufacturing wastes being dumped into coastal waters. The pollution of coastal waters can overwhelm the delicate balances of mangrove ecosystems.</p>	<p>Filter pollutants → Ultra Filtrators (ROOTS): Burguiera. Sonneratia and Rhizophora. Also store salt in their leaves so they can be shed.</p>							
<p>Rising sea level Gulf of Thailand: Rising sea levels, together with extreme storm activity, is likely to occur in future if climate change accelerates. Mangroves will have trouble colonising areas further inland despite sea level rise as they will be in competition with human activities such as farming and the construction of sea defences.</p>	<p>High Intensity full sunlight (tropical zones) → Leaves of mangroves thick and leathery to withstand heat</p> <p>Annual rainfall (1500 - 3000 mm) → Leaves of mangroves waxy with drip tips to allow excess water to drip off</p> <p>They are typically found along low-lying coasts and river estuaries, in anaerobic (oxygen poor) soils. Roots of mangrove (Rhizophora)</p>							

		<p>apiculate)</p> <ul style="list-style-type: none"> → Stabilise the plant in the unstable mud → Help obtain sufficient oxygen (Avicennia/ Sonneratia) → Take in water from the soil <p>Other ways of how mangroves adapt to an environment surrounded by water: Flowers and Fruits</p> <ul style="list-style-type: none"> → Fruits germinate on tree. long and sharp so can fall and anchor in the soil immediately e.g Bruguiera → Buoyant fruits (float in water) so they can float away to new coastal areas → Colourful flowers to attract insects to pollinate flowers 	
<p>Level 1 (0-3m)</p> <ul style="list-style-type: none"> • Brief mention of point/factor/method. • No/little examples given • One –sided argument <p>Level 2 (4-6m)</p> <ul style="list-style-type: none"> • Greater elaboration - detailed elaboration of point/factor/method • Simplified - Detailed elaboration on threats and adaptations <p>Level 3(7-8m)</p> <ul style="list-style-type: none"> • Conclusion that clearly showed candidate has answered the question 			



Geylang Methodist School (Secondary) Preliminary Examination 2017

HUMANITIES

2236/01

Paper 1 Geography

4 Express

Additional materials : Writing paper, Insert

1 hour 40 minutes

11 Aug 2017

READ THESE INSTRUCTIONS FIRST

Write in dark blue or black pen.

Do not use staples, paper clips, highlighters, glue or correction fluid.

The number of marks is given in brackets [] at the end of each question or part question.

Section A (25 marks)

Answer the question.

Section B (25 marks)

Answer **one** question.

You are encouraged to support your answers with the use of relevant examples, sketch maps and diagrams.

Begin your answer on a new and separate sheet of paper for each question.

Write all answers on the writing paper provided.

At the end of the examination, fasten all your work securely together.

This document consists of 8 printed pages.

Section A

Question 1 is compulsory for all candidates.

- 1 A group of students wanted to study about tourism in Sentosa Island, Singapore. Fig. 1 (Insert) shows a map of Sentosa Island. The students wanted to find out which part of Sentosa is the more popular destination among tourists and wanted to test the following hypothesis.
- Hypothesis:** The beach is the most popular tourist attraction in Sentosa.
- (a) Using Fig. 1, suggest a location in which the students can conduct their questionnaire and give your justifications. [3]
- (b) The students designed a questionnaire as shown in Fig. 2 (Insert).
- (i) What are some of the considerations that the students need to take into account to ensure that the data collection is reliable? [4]
- (ii) Discuss the advantages of open-ended questions in the questionnaire. [2]
- (iii) The students decided to categorise the tourist sites as shown in Fig. 3. Fig. 4 shows the results of parts of the questionnaire.

Categories of sites in Sentosa

Category 1: Heritage Sites	Category 2: Animal Kingdom	Category 3: Adventure	Category 4: Relaxation	Category 5
<ul style="list-style-type: none"> Fort Siloso Sentosa Merlion Images of Singapore Live 	<ul style="list-style-type: none"> Butterfly Park and Insect Kingdom Underwater World Singapore and Dolphin Lagoon S.E.A. Aquarium 	<ul style="list-style-type: none"> Adventure Cove Waterpark Skyline Luge Sentosa Universal Studios Singapore 	<ul style="list-style-type: none"> Beaches 	<ul style="list-style-type: none"> Others: _____ _____ _____ _____

Fig. 3

Results of questionnaire

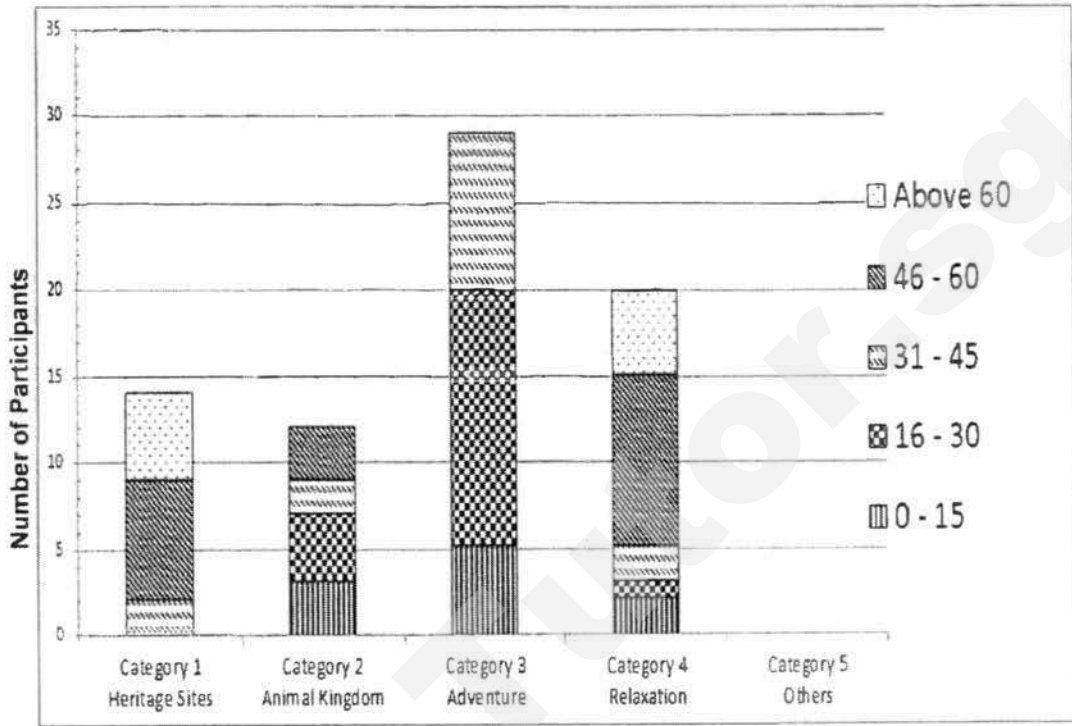

Fig. 4

Suggest another graph which can be used to represent the data shown in Fig. 4 and give reasons for your answer. [3]

(iv) Discuss the validity of the hypothesis as stated in 1(a). [3]

(c) Study Fig. 5A and Fig 5B, which show the results based on the last two questions of the questionnaire as shown in Fig. 2 (Insert).

Results of questionnaire

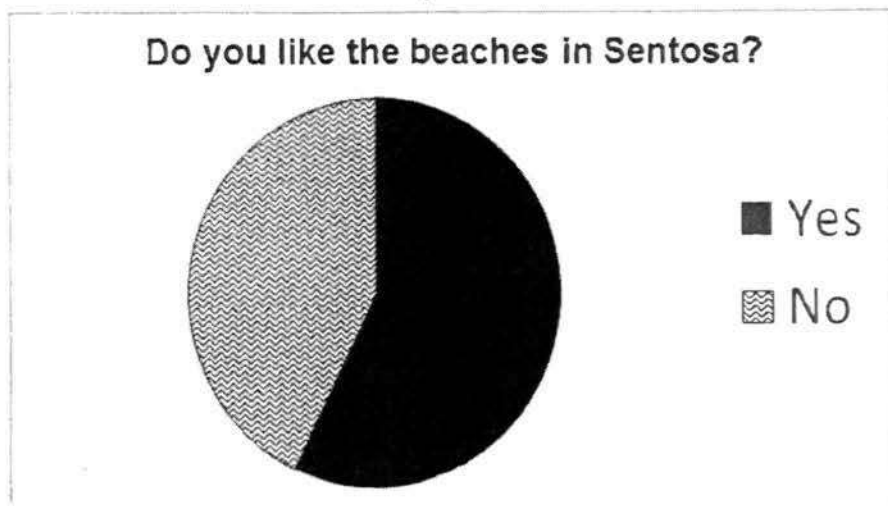

Fig. 5A**Reasons for whether the tourists like the beaches**

Yes	No
Clean, Not polluted	Artificial
Quite beautiful with its wide sandy beaches	Not a scenic view beyond the bay
Excellent facilities like nearby toilet, shower rooms, lifeguard	Too many no swimming zones and limited swimming areas
Not eroded like East Coast Park Beach	Too dirty

Fig. 5B

- (i) Design a perception survey to find out the tourists' impression of the beach. [3]
- (ii) Some of the students wanted to conduct another fieldwork to find out about the type of waves and the slope on a part of the beach in Sentosa as shown on Fig. 6 (Insert).
Draw an annotated field sketch of the beach as shown on Fig. 6 (Insert) [4]
- (iii) Describe how the students can go about collecting reliable data to determine the type of waves at the beach. [3]

Section B

Answer **one** question from this section.

- 2 (a) Study Fig. 7 which shows a coastal area.



Source: Global Road Trippers

Fig. 7

- (i) Identify the coastal feature labelled X. [1]
- (ii) With the aid of a diagram, explain the formation of feature X. [6]
- (b) Describe the conditions that are needed for corals to grow. [4]

- (c) Fig. 8 shows the distribution of mangroves.

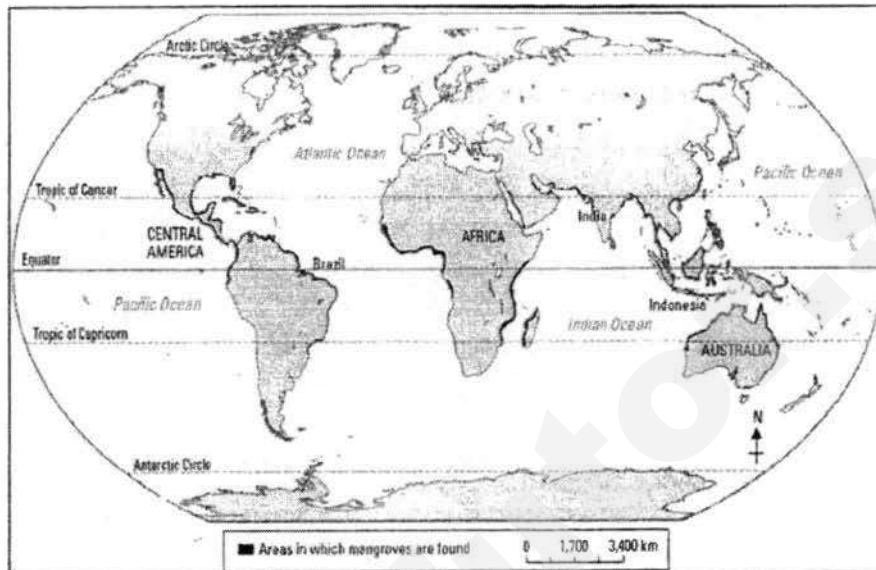

Source: Pearson

Fig. 8

- With reference to Fig. 8, describe the distribution of the mangroves. [3]
- (d) Describe the factors that will affect wave energy. [3]
- (e) 'Humans are the main cause of coastal destruction.'
With the use of specific examples, evaluate this statement. [8]

- 3 (a) Study Fig. 9 which shows the international visitor numbers and tourism receipts in Australia in 2014.

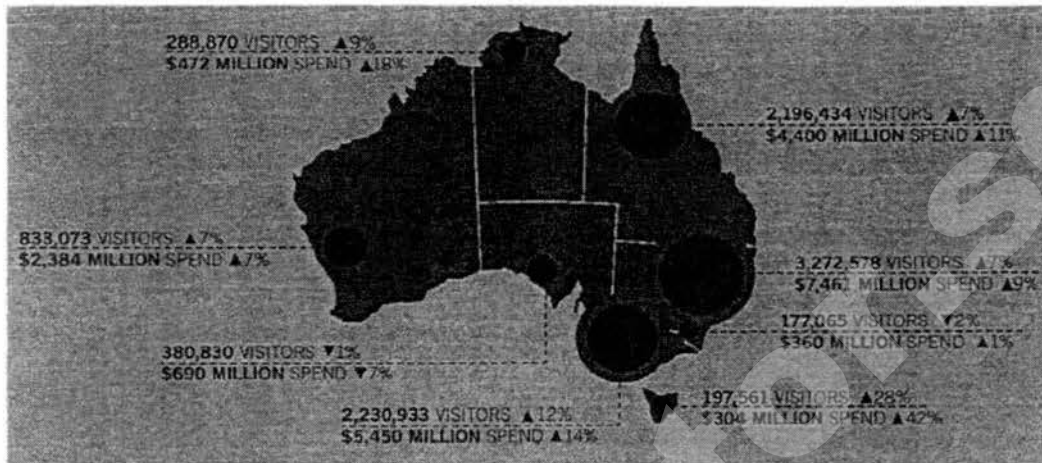

Source: tra.gov.au

Fig. 9

- (i) Describe the relationship between visitor arrivals and tourism receipts in Australia in 2014 in Fig. 9. [3]
- (ii) A popular tourist attraction in Australia is the Great Barrier Reef. Explain how tourism may have a negative impact on the coral reefs. [3]
- (b) With reference to specific examples, briefly explain how an outbreak of diseases can affect tourism. [4]
- (c) Fig. 10 shows a form of coastal protection.

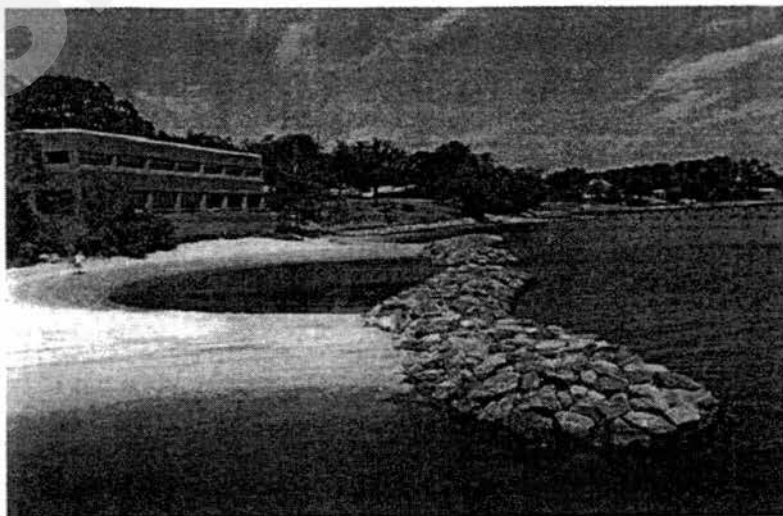

Source: <http://ccrm.vims.edu>

Fig. 10

Identify the coastal protection measure and explain the drawbacks associated with this measure. [3]

- (d) Fig. 11 is an extract from the Singapore Tourism Board.

Aligning this with existing marketing campaigns, STB has added new digital and social media initiatives to further increase interaction with target audiences from key markets, and exchange information and ideas online.

One of the recent initiatives was the strategic partnership forged with TripAdvisor. Through this partnership, STB is now able to provide updated user-generated content on YourSingapore.com, such as TripAdvisor ratings, reviews and opinions on Singapore's restaurants, attractions and shopping. The partnership also extends to the inclusion of our destination content on TripAdvisor's Singapore City Guides mobile application, which provides expertly curated itineraries, self-guided tours, transit maps, and hotel, restaurant, and attraction reviews from the TripAdvisor community.

STB also launched a suite of destination videos on the YourSingapore YouTube channel in March 2013.

Source: STB

Fig. 11

With reference to Fig. 11, explain how the use of different media could facilitate an increase in tourists traffic to Singapore. [4]

- (e) How far do you agree that local communities play a more important role than tourists in achieving sustainable tourism? Evaluate with the use of specific examples. [8]

END OF PAPER



Geylang Methodist School (Secondary)

Humanities
Department

Geography

Name: _____

Class: _____

Date: _____

Insert

A map of Sentosa Island, Singapore

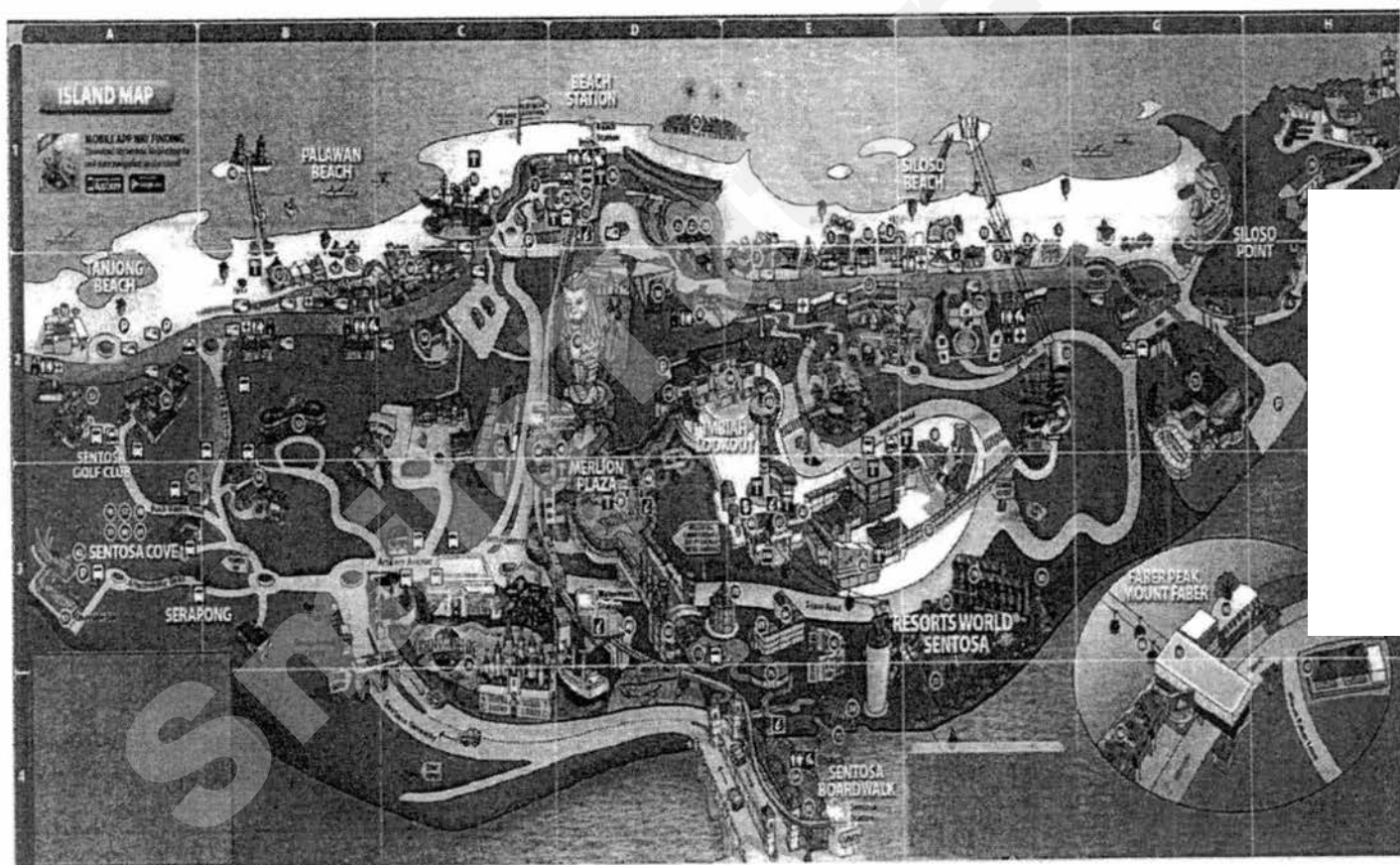

Fig. 1 for Question

GMS(S)/GY/P1/PRELIM2017/4E

Questionnaire

<p>Dear Participants, We are a group of students from Geylang Methodist and we would like to find out which is the most popular tourist site in Sentosa Island. Your inputs would help us greatly. This survey will only take 5 minutes. Thank you!</p>	
Gender:	<input type="checkbox"/> Male <input type="checkbox"/> Female
Age group (years old):	<input type="checkbox"/> 0 – 15 <input type="checkbox"/> 16 – 30 <input type="checkbox"/> 31 – 45 <input type="checkbox"/> 46 – 60 <input type="checkbox"/> Above 60
Country of Origin:	<input type="checkbox"/> Asia: _____ <input type="checkbox"/> Europe: _____ <input type="checkbox"/> Africa: _____ <input type="checkbox"/> Americas: _____ <input type="checkbox"/> Middle East: _____ <input type="checkbox"/> Others: _____
How many times have you been to Sentosa?	<input type="checkbox"/> 1 <input type="checkbox"/> 2 to 3 <input type="checkbox"/> 4 to 5 <input type="checkbox"/> Above 5 times
Which of the following places do you most look forward to visiting in Sentosa?	<input type="checkbox"/> Fort Siloso <input type="checkbox"/> Sentosa Merlion <input type="checkbox"/> Images of Singapore Live <input type="checkbox"/> Butterfly Park and Insect Kingdom <input type="checkbox"/> Underwater World Singapore and Dolphin Lagoon <input type="checkbox"/> S.E.A. Aquarium <input type="checkbox"/> Adventure Cove Waterpark <input type="checkbox"/> Skyline Luge Sentosa <input type="checkbox"/> Universal Studios Singapore <input type="checkbox"/> Beaches <input type="checkbox"/> Others: _____
For the choice you have indicated, explain why:	<hr/> <hr/>
Do you like the beaches in Sentosa?	<input type="checkbox"/> Yes <input type="checkbox"/> No
Why or why not?	<hr/> <hr/>

Fig. 2 for Question 1

A beach at Sentosa**Fig. 6 for Question 1**



Geylang Methodist School (Secondary) Preliminary Examination 2017

HUMANITIES

2236/2

Paper 2 Geography

4 Express

Additional materials :
Writing paper

1 hour 30 minutes
16 August 2017

READ THESE INSTRUCTIONS FIRST

Write in dark blue or black pen.
Do not use staples, paper clips, highlighters, glue or correction fluid.

Section A

Answer **one** question.

Section B

Answer **one** question.

Write all answers on the writing papers provided.
Candidates should support answers with the use of relevant examples.
Sketch maps and diagrams should be drawn whenever they serve to illustrate an answer.

At the end of the examination, fasten all your work securely together.
The number of marks is given in brackets [] at the end of each question or part question.

Section A

Answer one question from this section.

- 1 Study Fig. 1, which shows information on Typhoon Vongfong moving across Japan.

Map of Typhoon Vongfong moving across Japan

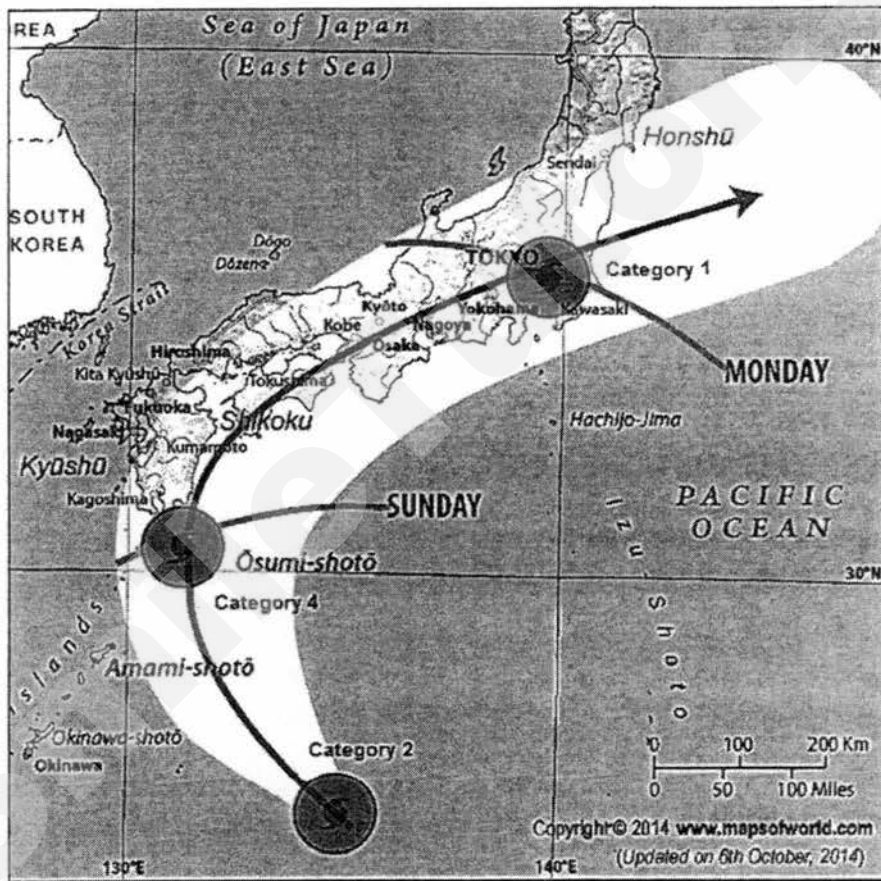

Fig. 1

- (a) Based on Fig. 1, describe and account for the path and intensity of Typhoon Vongfong moving across Japan.

[5]

- (b) Study Fig. 2, which shows where major earthquakes have taken place in California, USA.

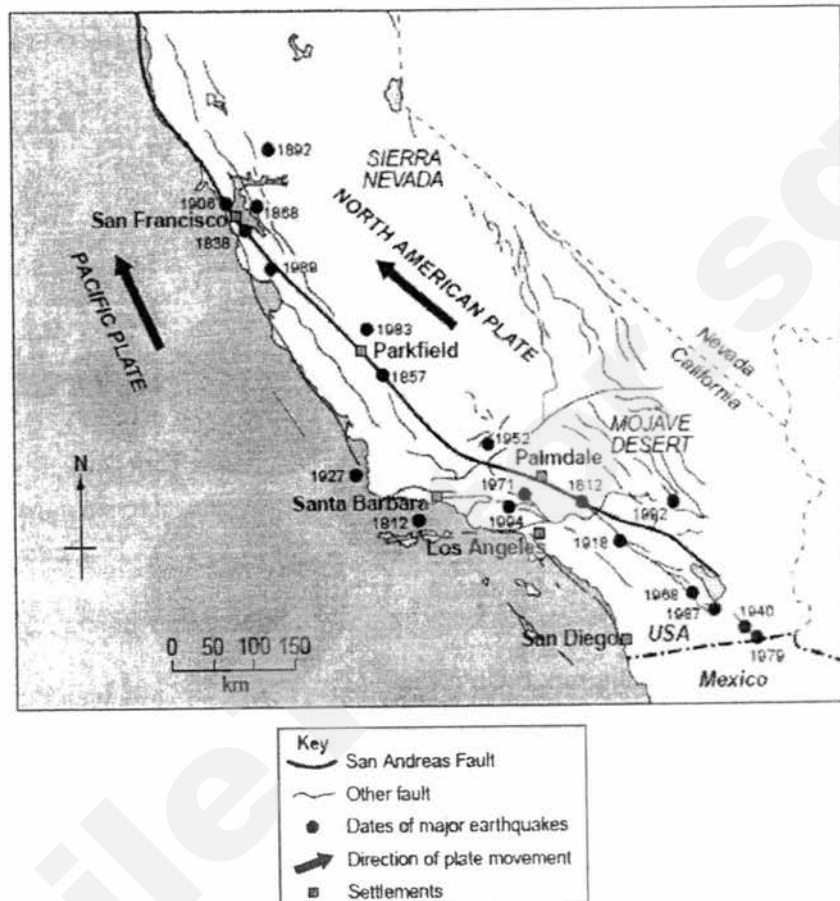

Fig. 2

- (i) San Francisco was affected by an earthquake in 1989.
 What was the distance and direction of this earthquake from San Francisco? [2]
- (ii) Explain why earthquakes take place on or close to major faults, such as the San Andreas Fault. [5]
- (c) Compare the landforms and processes involved when two continental plates converge and two continental plates diverge. Support your answer with relevant examples. [5]
- (d) 'Unlike volcanic areas where people stay for the benefits despite the hazards, earthquake zones only bring hazards for people living there.'
 To what extent do you agree with the statement? Give reasons to support your answer. [8]

- 2 (a) Study Fig. 3, which shows some impacts to United States by Hurricane Sandy in 2012.

Information on Hurricane Sandy in 2012

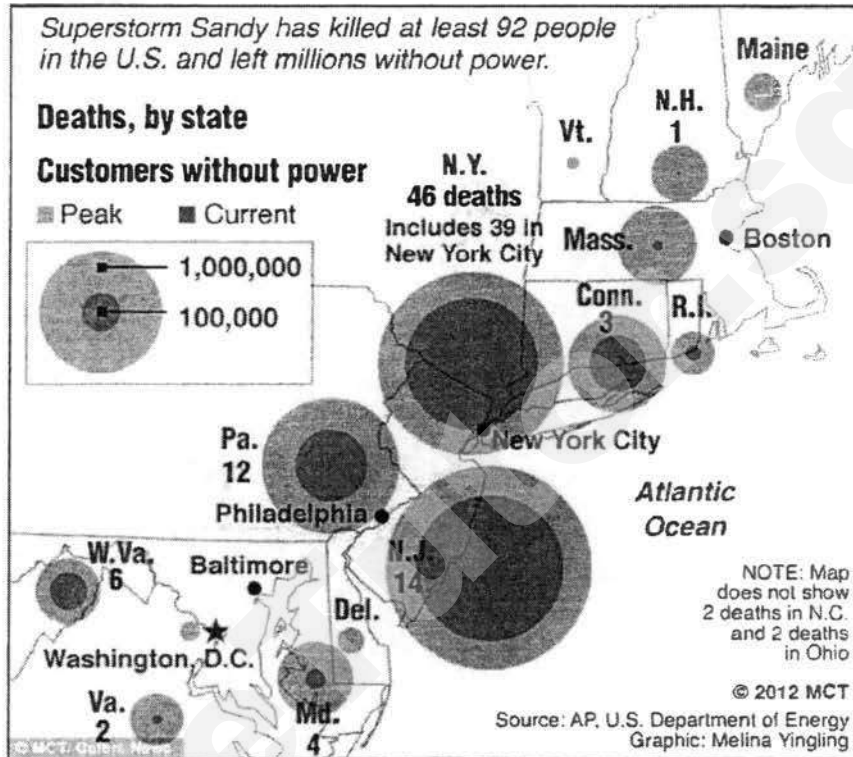

Fig. 3

- (i) Based on Fig. 3, describe the distribution of the current impact of Hurricane Sandy. [4]
- (ii) With reference to Fig. 3 and studies made, explain the economic impacts of Hurricane Sandy. [4]
- (b) Discuss the effectiveness of the Kyoto Protocol. [4]

- (c) Study Fig. 4, which shows the distribution of tropical climate zone.

World Map showing Geographical Distribution of Tropical Climate Zone

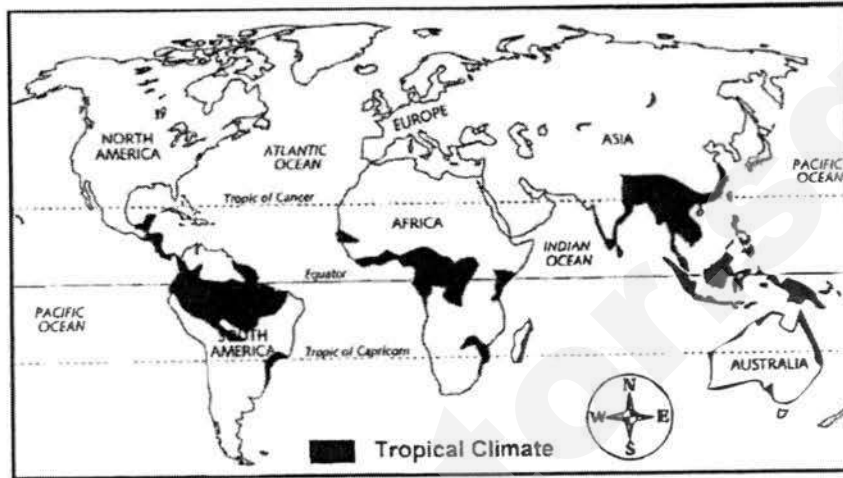

Fig. 4

Using Fig. 4, describe the distribution of the tropical climate zone in the world. [5]

- (d) 'The impacts of climate change are not limited to the environment.' Discuss. Support your answer with relevant examples. [8]

Section B

Answer **one** question from this section.

- 3 Study Fig. 5, which shows the food consumption in Asia in 1970 and 2009.

Food consumption in Asia in 1970 and 2009

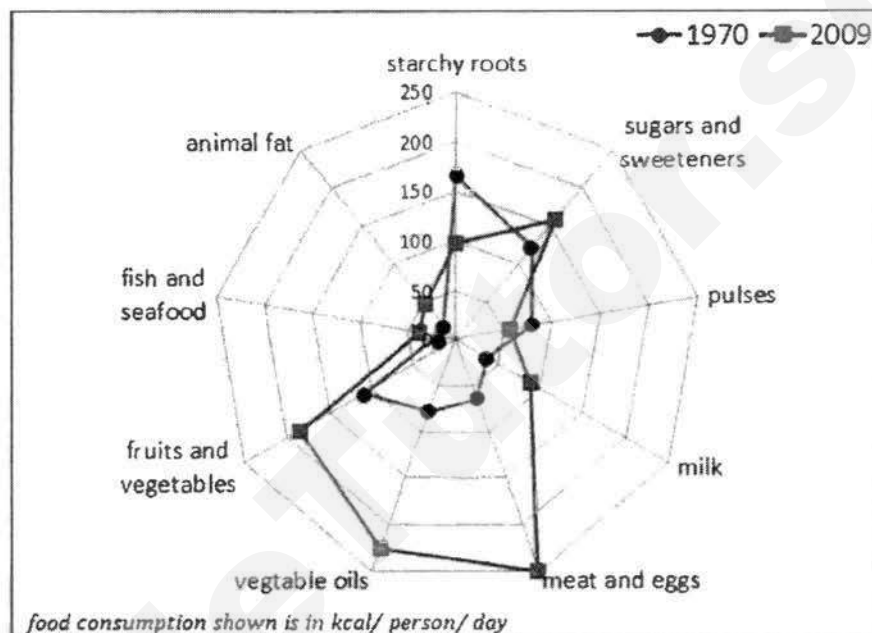

Fig. 5

- (a) (i) Using Fig. 5, describe how the consumption of different food types has changed from 1970 to 2009. [5]
- (ii) Account for the changes mentioned in (a)(i). [4]
- (b) Discuss the effectiveness of food aid and food programmes from the international communities to the countries that are facing food shortages. [5]

- (c) Study Fig. 6, which shows the world's major rice-growing regions.

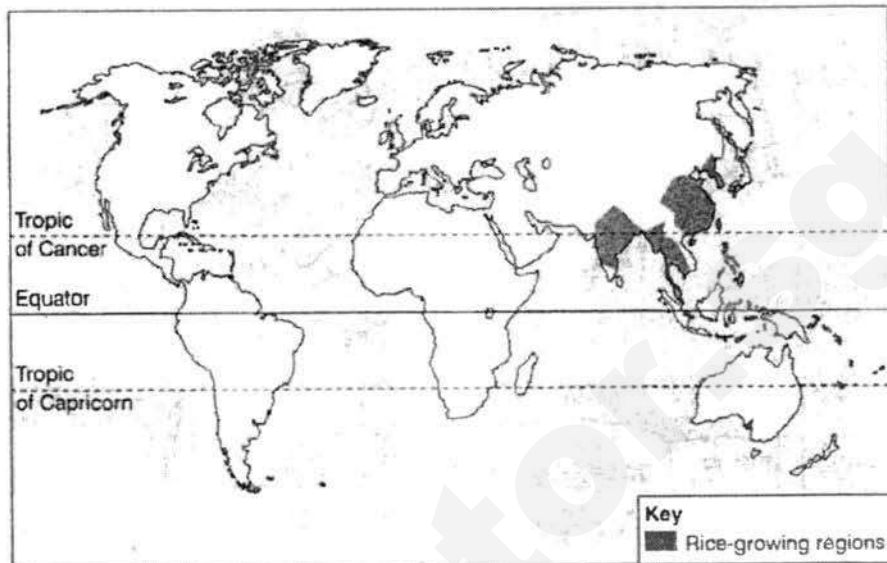

Fig. 6

Describe the distribution of major rice-growing regions in the world shown in Fig. 6 and explain how physical factors may affect the production of rice in these places. [5]

- (d) 'Intensification of food production cannot be carried without harming the environment.'

Do you agree with this statement? Explain your answer with examples. [8]

- 4 (a) Study Figs. 7a and 7b, which show two different types of farming.

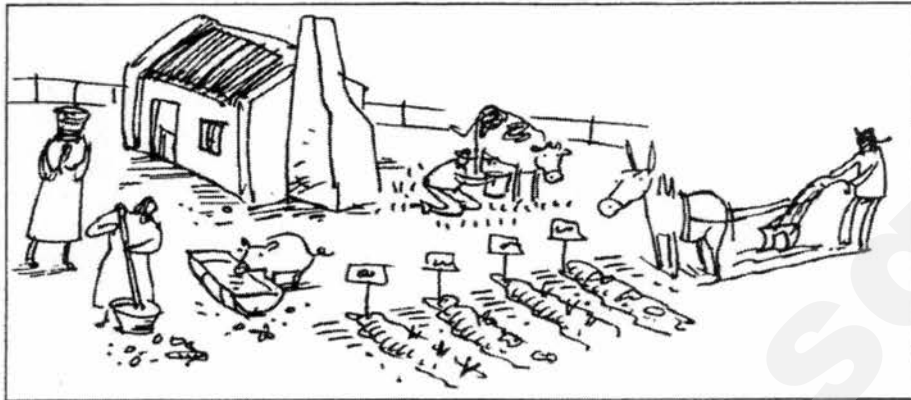

Fig. 7a



Fig. 7b

- Compare the two types of farming shown in Figs. 7a and 7b and their productivity. [5]
- (b) With the use of examples, explain how infectious diseases may spread from its source of origin. [4]
- (c) Study Fig. 8, which shows the percentage of HIV prevalence by age in South Africa from 1991 to 2001.

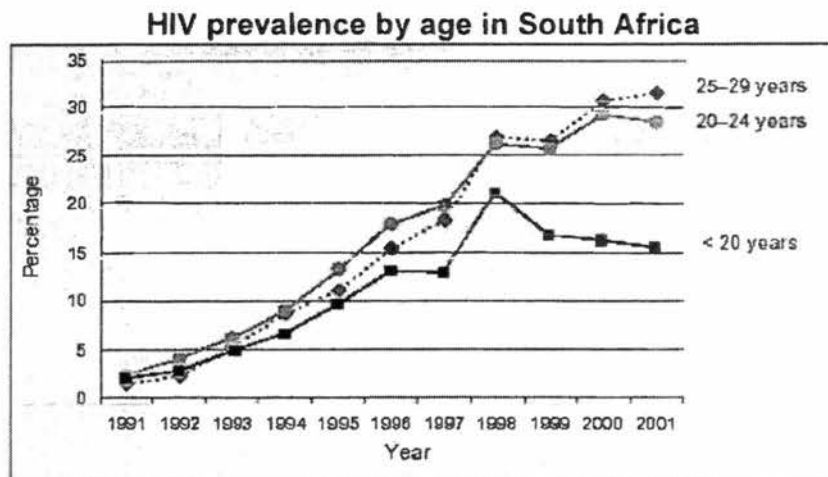

Fig. 8

- (i) Based on Fig. 8, describe the trend of HIV prevalence by age in South Africa from 1991 to 2001. [3]
- (ii) Describe the impacts of HIV experienced by the people in South Africa. [4]
- (d) 'Eradication of infectious diseases around the world cannot be done without individual responsibility.'
- How far do you agree with this statement? Give reasons for your answer. [8]

END OF PAPER

BLANK PAGE

SmileTutor.sg

Copyright Acknowledgement

- Fig. 1 ©<http://images.mapsofworld.com/world-news/Japan-typhoon.gif>
Fig. 2 © UCLES 2007
Fig. 3 © www.energy.gov
Fig. 4 © <http://ryecityschools.osborn.schoolfusion.us/modules/cms/pages.phtml?sessionId=&pageid=96748>
Fig. 7a © <https://climateadaptationcafe.files.wordpress.com/2014/03/farming.png>
Fig. 7b © <http://archive.cnx.org/resources/813b269500c19d056616dcce0ced5049dfcdd18/graphics2.png>
Fig. 8 © <http://www.microbiologybook.org/lecture/images/south-africa.gif>

Need a home tutor? Visit smiletutor.sg

[Turn Over

Answer Scheme for Sec 4E Core GY Paper1 EOY2017

Section A

This question is compulsory

1		
a)	<p>The location and justifications are:</p> <ul style="list-style-type: none"> • They could conduct their questionnaire at Sentosa Station or Sentosa Boardwalk as it is the entrance to Sentosa Island where the tourists would likely pass by to enter it. • Hence there will be high human traffic in the area which can be a good place to find the respondents for the questionnaire. • The location is thus not biased and it is neutral. 	[3]
bi)	<p>The considerations to ensure its reliability include:</p> <ul style="list-style-type: none"> • They need to ensure a large sample size to ensure that the data will be representative of the tourists at Sentosa. • They need to decide on a suitable sampling method such as systematic sampling. • They need to consider a suitable location to conduct the questionnaire in order to reduce biasness and obtain a large representative sample size. • They need to consider a suitable time and duration, i.e. of a higher frequency and longer duration, of conducting the questionnaire to obtain a representative sample of different tourists groups. • They should also standardise the procedures in posing questions to respondents. <p><i>Accept any 4 points</i></p>	[4]
bii)	<p>The advantages of open-ended questions are:</p> <ul style="list-style-type: none"> • Respondents are able to present their own ideas without having to select from predetermined categories which makes the data more accurate. • It enables the researcher to obtain data on genuine tourists' attitudes and perceptions • Their answers in the close-ended questions would not be restricted to inflexible choices and hence capture diverse viewpoints. <p><i>Accept any 2 points</i></p>	[2]
biii)	<ul style="list-style-type: none"> • Pie chart / comparative bar graph • A pie chart for each category can be used to show the percentage total for the different categories by the different age groups. • The 4 pie charts would be easy to interpret hence making it easy to analyse and compare among the categories. 	[3]
biv)	<ul style="list-style-type: none"> • The hypothesis is not valid. • The most popular attraction in Sentosa is not the beach as only 20 out of the 75 respondents chose the beach as their choice of attraction to visit. • The most popular attraction is actually under the adventure category which includes the Adventure Cove Waterpark, Skyline 	[3]

	<p>Luge Sentosa and the Universal Studios Singapore as 29 out of 75 respondents chose that category as their choice of attraction to visit.</p> <p><i>[Reserve 1m for validity. Max 2m if no evidence]</i></p>																																											
ci)	<p style="text-align: center;">Tourists' Impression of the beach</p> <table border="1"> <thead> <tr> <th>Negative</th> <th>-2</th> <th>-1</th> <th>0</th> <th>+1</th> <th>+2</th> <th>Positive</th> </tr> </thead> <tbody> <tr> <td>Overcrowded</td> <td></td> <td></td> <td></td> <td></td> <td></td> <td>Uncongested</td> </tr> <tr> <td>Dirty</td> <td></td> <td></td> <td></td> <td></td> <td></td> <td>Clean</td> </tr> <tr> <td>Eroded</td> <td></td> <td></td> <td></td> <td></td> <td></td> <td>Well-managed</td> </tr> <tr> <td>Ugly</td> <td></td> <td></td> <td></td> <td></td> <td></td> <td>Beautiful and Scenic</td> </tr> <tr> <td>Poor facilities</td> <td></td> <td></td> <td></td> <td></td> <td></td> <td>Excellent facilities</td> </tr> </tbody> </table> <p>[Award 1m for suitable range, 1m for title Award 1m for suitable categories in the perception survey]</p>	Negative	-2	-1	0	+1	+2	Positive	Overcrowded						Uncongested	Dirty						Clean	Eroded						Well-managed	Ugly						Beautiful and Scenic	Poor facilities						Excellent facilities	[3]
Negative	-2	-1	0	+1	+2	Positive																																						
Overcrowded						Uncongested																																						
Dirty						Clean																																						
Eroded						Well-managed																																						
Ugly						Beautiful and Scenic																																						
Poor facilities						Excellent facilities																																						
cii)	<p>[Reserve 1 m for accurate sketching of beach Award 1 m for every 1 annotations, Max 3m in total if only labelled]</p>	[4]																																										
ciii)	<ul style="list-style-type: none"> The students can determine if the waves are destructive or constructive by calculating the wave frequency. Wave frequency is estimated by counting the number of waves over a 10 minute period and dividing the total by the number of 	[3]																																										

	minutes to determine number of waves per minute. <ul style="list-style-type: none"> • Students could observe the waves and record down the number of waves breaking per minute in a table in a recording sheet. • If the wave frequency is 10 or more per minute, then the waves are destructive. Accept any 3 points	
--	---	--

Section B

Answer one question from this section.

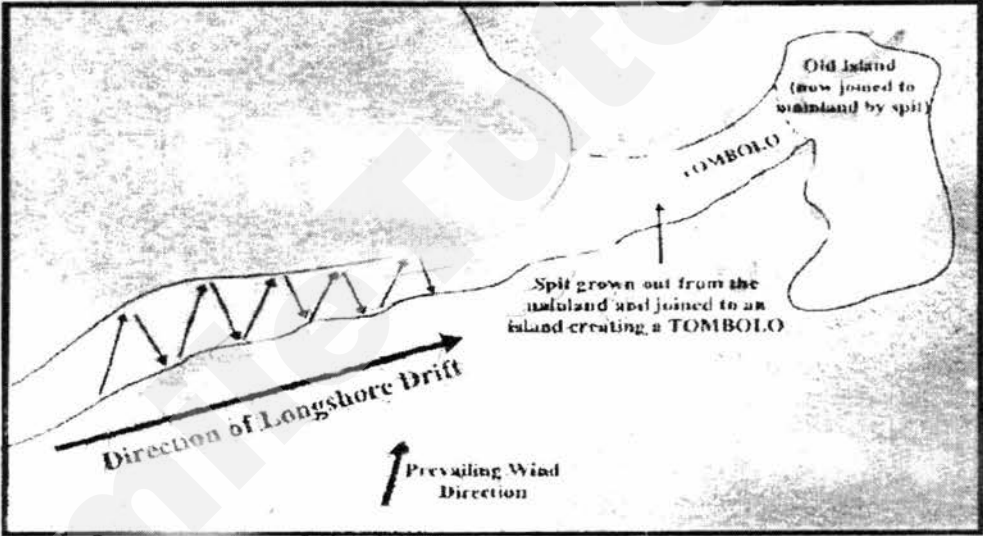
2		
a)	Tombolo	[1]
aii)	<p>Formation of a Tombolo</p>  <ul style="list-style-type: none"> • Formed by longshore drift which is a combined movement of waves and longshore currents. • Waves moving obliquely at the shore move materials in a zig-zag manner by the swash and backwash, and along the seabed parallel to the coast by longshore currents. • When the coast bends abruptly, the longshore drift continues to transport materials in its original direction for some distance, into the sea. Larger materials are deposited in the slack water and finer materials are carried further away • When the deposits are adequate enough to rise above the water, a spit is formed. • When the spit joins with an offshore island, it will form a tombolo. <p>Reserve 2 m for diagram and any 4 points for explanation</p>	[6]
b)	<ul style="list-style-type: none"> • Corals need a warm sea surface temperature of about 17-18°C to survive as they are found in the tropics. • Clear waters are ideal for its growth as this allows sunlight to reach 	[4]

	<p>them and help them to carry out photosynthesis to ensure its growth.</p> <ul style="list-style-type: none"> • The seabed must not be too deep so that the coral can grow and have enough sunlight reaching them. • Next there must not be too many sediments in the water as this will may suffocate the living corals and kill them. • There has to be average salinity of 34 to 37 parts per thousand to ensure proper growth. • In addition, the waters have to be relatively calm so that the waves will not destroy the corals and will not stir up too much sediment at the sea bed. • Lastly there has to be some water movement to ensure that there are sufficient levels of oxygen being produced. <p>Accept any 4 points</p>	
c)	<ul style="list-style-type: none"> • They are not found at higher latitudes in the northern hemisphere. The mangroves are mostly found within the Tropic of cancer and Tropic of Capricorn. • Most mangroves are found along the coast near the ocean. They are concentrated in regions of Southeast Asia, Africa and Central America. • They are found along Tropical coasts like Malay Peninsula, Borneo, northern Australia 	[3]
d)	<p>The factors that will affect wave energy are:</p> <ul style="list-style-type: none"> • The faster the wind blows, the greater the wave energy will be the stronger wind speed will drive the waves faster. • The longer the wind blows, the larger the waves are due to the longer duration that the wind is blowing at the water. • The greater the fetch, the more energy the waves will have as the waves travel across greater distance resulting in accumulating in more energy 	[3]
e)	<p>Human factors are the main cause of coastal destruction:</p> <p><u>Natural threats to the coasts</u></p> <p>Climate change</p> <ul style="list-style-type: none"> • Rising sea levels which could submerge low-lying coasts, sandy beaches and deltas and river estuaries • Coastal ecosystems may not be able to adapt to the change • But warmer temperatures may encourage mangrove survival and growth in new areas although reduced rainfall and rising salinity levels of the sea could also mitigate the positive effects. • For example in Seychelles, there are reports of large scale coral bleaching to higher sea temperature, slowly killing the coastal coral reefs. <p>Eroding shore lines</p> <ul style="list-style-type: none"> • Increased, more severe storms because of climate change could rapidly erode beaches and alter shore lines 	

- Due to rising sea level at the Gulf of Thailand, there is lost fresh water around the coastal area, leading to the lost of mangrove forest.

Man made threats

Increasing population & rising demand for coastal resources

- With more than 3billion of the earth's population living within 100 km of the coasts, puts greater pressure on land and water resources
- More demand for new ports, housing which will exploit coastal resources for food and building materials.
- In Indonesia large areas of mangrove are cleared by the people for charcoal, particularly in regions with low technology and low economies as they have to depend on the mangrove forest for the resources.

Coastal Development

- Habitat loss will result from expansion of human activities along the coast
- E.g mangroves and coral reef ecosystems may be threatened by the wide spread and rapid conversion into aquaculture activities.
- In Japan and Florida (USA), land reclamation and expansion of coastal resorts and housing have led the corals being suffocated by sediments.

Pollution

- Waste disposal into the sea can destroy the coast and endanger marine life
- Aquaculture in Ca Mau, Vietnam has been responsible for creating waste and waste water that pollutes the surrounding coastal waters affecting the quality of the water

Conclusion: Natural changes in the climate could have led to melting of polar icecaps, leading to rise in sea level which leads to flooding and erosion of coastal areas. In addition, natural disasters like massive storms will also lead to erosion of costal areas. However human factors play a greater in destroying the coastal landscape, especially due to rapid development along the coastal areas for industrial needs, housing and recreational needs as seen from the large loss of corals and mangroves in Indonesia, Japan and Florida. Hence human factors are the main cause of coastal destruction.

Level 1 (0-3m)

Answers will be generalized or with minimal support if any given at all. Reasoning rather weak and expression may be unclear. A basic answer that has little development. Answers lack examples or other evidence, or it is so sketchy that it adds little support to the answer.

	<p>Level 2 (4-6m)</p> <p>Disagreement <u>or</u> agreement will be supported by appropriate detail. Or, both agreement and disagreement are considered, but support is patchy so that the answer is not full. Good reasoning and logic in parts of the answer with good expression in places. Some examples or other evidence will be presented to support answers in at least one place in the answer.</p>	
	<p>Level 3 (7-8m)</p> <p>Answers will be comprehensive and supported by sound knowledge. Both agree <u>and</u> disagreement are considered and well supported. Reasoning is clear and logical with good expression of language. Examples or other evidence to support answers will be extensive.</p>	
3		
ai)	<ul style="list-style-type: none"> • Direct relationship or As visitor arrivals increase, tourism receipts in Australia increase • An increase of 7% of visitors in the western coast of Australia has resulted in an increase in the tourism receipts by 7%. • Anomaly: The western coast of Australia which experiences a decrease in visitors by 2% however experiences an increase in spending by 1%. 	[3]
aii)	<ul style="list-style-type: none"> • Tourists who travel to snorkel and dive to view the beauty of coral reefs that leads to sediments being stirred, smothering coral reefs, leading to its death • Aesthetic value of coral reefs has resulted in divers removing coral reefs from the seabed that kills the reefs and threaten its ecological balance • Tourists who travel to view coral reefs in boats due to careless boating has damaged coral reefs 	[3]
b)	<ul style="list-style-type: none"> • Outbreak of diseases discourages tourist travel as people do not want to risk getting infected with a contagious disease <p>E.g. outbreak of SARs (Severe Acute Respiratory Syndrome) in 2003.</p> <ul style="list-style-type: none"> • Hong Kong - 41% reduction in tourism GDP/ hotel occupancy dropped from 82% to 15 % • Singapore - 43% reduction in tourism GDP/ visitor arrivals in Singapore dropped by 67 % , hotel occupancy decreased by 45%, Orchard Rd retailers badly hit • China - 25% reduction in tourism and a loss of 2.8 million jobs <p>WHO raised concern over H1N1 (swine flu) in 2009.</p>	[4]

	<ul style="list-style-type: none"> • Mexico - estimated loss for the Mexican tourism industry was \$5 billion • widespread cancellation of holiday bookings to Mexico/ USA/ Europe <p>Outbreak of MERs (Middle East Respiratory Syndrome) in 2015</p> <ul style="list-style-type: none"> • S Korea - 23 dead, 28000 quarantined, tourism was badly affected as tourists cancel their trip to S Korea <p><i>Max 2m if there are no specific examples.</i></p>	
c)	<ul style="list-style-type: none"> • It is a breakwater • They are aesthetically unappealing and are costly to build. • Breakwaters also protect the coast unevenly. Materials deposited in the zone behind the breakwaters are protected while those in the zones located away from breakwaters are subjected to wave action and possible erosion. 	[3]
d)	<p>The use of different media can:</p> <ul style="list-style-type: none"> • Reach out to newer, younger audience and potential tourists who are more independent travellers. • Using personal stories and visual to sell Singapore to cater to niche markets. • Provides alternative travel sites rather than the usual attractions to attract repeat tourists. • Use of media and collaboration with airline and accommodation portal such as TripAdvisor can help tourists have a seamless experience for travel. 	[4]
d)	<p>Sustainable tourism is a form of tourism organized in a way that allows it to continue without damage to the environment or without leaving negative impacts on surrounding society and culture</p> <p><u>Local Communities</u></p> <ul style="list-style-type: none"> • Local community refers to a group of people living in the same territory • Local communities may partner with a government or non-governmental organization (NGO) to achieve sustainable tourism by minimizing damage to the environment <ul style="list-style-type: none"> ◦ Locals have a good knowledge of their environment and needs and can give better feedback or input on tourism related issues when consulted. Hence, decisions made are less likely to harm their natural environment or way of life • Local communities can achieve sustainable tourism by minimizing leakage so that they gain economically through community-based tourism <ul style="list-style-type: none"> ◦ Community-based tourism increases tourism-related employment and business for locals and as a result raises average income and reduces leakages <ul style="list-style-type: none"> ▪ Locals are employed as guides, waiters, cleaners, drivers, hotel staff etc which tend to pay better than farm jobs • E.g. Candirejo Village, near Borobudur in Central Java, Indonesia 	[8]

- With government support, villagers set up a cooperative in 2003 to manage and implement tourism related programmes
- Villagers participated in decision making through discussions and consultations with the cooperative about the programmes
- E.g. develop homestays, organic farms, promote local transport, train villagers to produce local handicrafts, set up catering business, and be tour guides.
- Achieved positive impact on locals, the problem of leakage is minimized as local businesses keep profits within the economy – these are evidence of sustainable tourism
 - 2002 to 2004, homestays increased from 10 to 22, andongs (traditional horse cart transport) increased from 5 to 22 (hence pollution decreased)
 - 63 new jobs created from new businesses e.g. creation of 6 local restaurants
 - 2001 to 2003 - 12.5% increase in average income per villager

However,

- Some local communities, especially in LCDs, may face difficulty in obtaining external funds to set up businesses or invest in vehicles to promote sustainable tourism in their community.
- There could be a shortage of skilled labour. e.g. locals are not qualified to be managers or consultants to help manage the impact of tourism. In such cases, the local community needs to seek the help of NGOs or other organisations to provide the expertise or training.

Tourists

- Visitors or tourists can help to achieve sustainable tourism if they are responsible enough to respect both the environment and the local community.
- They can try to minimize their carbon footprint during holidays by not using water or electricity excessively to avoid depleting resources and hence damaging the environment.
- E.g. the Tourism Sustainability Group set up by the European Commission in 2004 encouraged tourists to select their holiday destinations based on the conservation efforts of the place in its report in 2007.
- Visitor spending (e.g. entrance fees, purchase of souvenirs) can provide funds for conservation of the natural environment.
 - E.g. Sasaab Lodge in Samburu National Park in Kenya, Great Barrier Reef, Australia
- Visitor spending can also provide locals with income from employment and businesses, hence achieving sustainable tourism
 - E.g. Candirejo villagers' income increased by 12.5% from 2001 to 2003 when they provided homestays, set up organic farms and restaurants etc.
 - E.g. Pamilacan Island in the Philippines - local tour agents pay fishermen between US\$ 80 and 100 per boat for fishing/ tour service. This represents significant earnings for the locals.
- Visitors increase their awareness on the need for conservation when they travel to particular destinations. They can raise others' awareness

when they return home and share their experience and concerns to promote sustainable tourism.

However,

- Irresponsible behavior by tourists can damage tourist attractions, hence sustainable tourism cannot be achieved
- Environmental problems include:
 - E.g. littering of the Inca Trail in Machu Picchu, Peru by tourists
 - E.g. tourists collecting corals as souvenirs in the Red Sea area/ Great Barrier Reef of Australia
- Too many visitors to a place can cause strain to the environment through trampling, noise or touch.
 - E.g. Machu Picchu Trail received numerous tourists yearly hence more soil erosion and destruction of flora and fauna has been observed
- Visitors who do not respect locals can dilute local culture and customs or values especially if large numbers flock to an area.
 - E.g. Bali, Indonesia - conservative may be influenced to become more 'liberal' when they observe tourists publicly displaying affection

In conclusion, the role of local communities are not more important than tourists. Both are as important. Locals have good knowledge of their environment and can advise on conservation issues. Tourists must be responsible enough to heed such advice and respect the locals and their environment during their trips. As both parties work together, it is easier to achieve sustainable tourism.

Level	Descriptor
L1 (0-3m)	Simple statements on local communities in achieving sustainable tourism. No elaboration/examples given
L2 (4-6m)	Provide coherent description on local communities in achieving sustainable tourism. General examples given Provide coherent description on 1 other group in achieving sustainable tourism like tourists.
L3 (7-8m)	Provide convincing and detailed explanations on local communities in achieving sustainable tourism. Provide convincing and detailed explanations on 1 other group in achieving sustainable tourism like tourists. Specific examples given + Conclusion

Answer Scheme

1	(a)	<p>Describing the path of the typhoon:</p> <ul style="list-style-type: none"> The typhoon built up momentum over the Pacific Ocean with a Category 2 and intensified to Category 4 just before hitting Japan. It makes landfall on the Eastern Coast of Japan near Kagoshima. The typhoon continues its path by moving northwards along the eastern coast of Japan, devastating places such as Osaka, Nagoya, finally subsiding to Category 1 on the eastern coast of Japan, just east of Honshu Island. <p>Account for the path of Typhoon Vongfong:</p> <ul style="list-style-type: none"> The eastern coast of Japan faces the Pacific Ocean, which in the summer heats up above 26.5 degrees Celsius. Heat and moisture from the ocean waters are required for the typhoon to form. Land masses to the Northwest acts as buffers, therefore typhoons are unlikely to form along the western coast of Japan. A tropical cyclone over land will begin to weaken rapidly because land lacks the moisture and heat sources that the oceans provide. This depletion of moisture and heat hurts the tropical cyclone's ability to produce thunderstorms near the storm's center. Without this convention, the storm rapidly subsides. Also, sea temperatures by and large remain constant and vary very little, which helps in the genesis and the further growth of a cyclone. Whereas cyclones usually dissipate over land or over colder regions where the temperature profile varies widely and changes constantly. Cyclones always form over the sea, in open spaces and that's where they gain strength. The terrain of the sea helps a storm gather its maximum strength whereas on land that strength is immediately cut off due to much resistance around. The increased friction over land acts as an obstacle, i.e. in the form of bushes, trees and houses and buildings, thus decreasing the speed of sustained winds. These sustained winds become weaker because of the dampening effect of larger roughness i.e. over land versus a relatively smooth ocean <p>Reserve 2m for description and 3m for explanation</p>	[5]
	(b)(i)	67-100km SE/SSE	[2]
	(b)(ii)	<ul style="list-style-type: none"> Faults are line of weakness and the major faults such as San Andreas Fault are found along transform plate boundaries between the Pacific and North American plates. These plates are moving at either side of the faults/alongside each other/sliding past each other. They move at different pace and in different directions from each other. Thus, they are locked and stuck together due to the friction involved as they movements are not smooth. This causes the build up of pressure and when the rocks can no longer withstand the pressure, the plates jerk apart or have a sudden movement to release the pressure. The energy is released in the form of seismic waves which cause tremors on the earth surface, causing earthquakes to form. 	[5]
	(c)	C-C Converge	[5]
		C-C Diverge	

Similarity	Both result in the formation of mountains but they are different types of mountains.	
Differences		
Landforms	<p>Fold mountain</p> <p>Eurasian and Indian plates forming the Himalayas</p>	<p>Rift valley Block mountains</p> <p>Somalian and Nubian plates forming the East African Rift Valley and block mountains</p>
Processes	<p>Involves compressional forces</p> <p>When the plates converge and being compressed, folding is involved.</p> <p>They plates resist subduction due to similar density of the plates and the rocks on the upper layer will crumble along line of weaknesses and start to fold</p>	<p>Involves tensional forces</p> <p>When the plates diverge, faulting is involved.</p> <p>The faults created caused the centre section of the plates to subside forming a linear depression called the rift valley. The sections left standing are the block mountains.</p>

(d)	<p>Hazards of earthquake zones:</p> <p><u>Tsunamis</u> Earthquakes may lead to tsunamis, which can cause widespread destruction at coastal areas when it sweeps inland. E.g. 9.2 magnitude earthquake in Indian Ocean (2004) – affected coastal areas of 12 countries. The greatest damage was in low-lying areas in Sumatra, Indonesia, especially the town of Aceh. Tsunami in Aceh was between 4m to 39m high, and went as far as 10km inland. Houses were swept away.</p> <p><u>Disruption of services and fire</u></p> <ul style="list-style-type: none"> - Earthquake can disrupt services like the supply of electricity, gas and water - Vibrations on the ground can break pipes and cables, which can cause fires to start - Fires have the ability to spread quickly over a large area. - Communication services such as television broadcasts and telephone connections may also be affected. - E.g. Earthquake in Kobe (Japan) in 2004 – Pipes and transmission cables were damaged. Electricity, gas and water supplies were disrupted, affecting 1.4 million residents. <p><u>Landslides</u></p> <ul style="list-style-type: none"> - The shaking of the ground during an earthquake can weaken the slopes of hills and mountains and unstable slopes will cause landslides. - Heavy rain may also lead to mudflows. 	[8]
-----	---	-----

- E.g. Earthquake in Peru in 1970 – destabilized the slope of a volcano (Mt. Huscaran) and triggered a massive landslide that travelled over 160km/h and flattened the town of Ranrahica within seconds. More than 18 000 people died and only 200 people survived.

Destruction of property and infrastructure

- Earthquakes can cause damage to homes, buildings and infrastructure like roads, bridges and buildings.
- People may end up homeless after an earthquake occurs and may live in temporary shelters while waiting for their homes to be built
- Transportation may be affected as it is unsafe for people to use damaged roads
- E.g. Earthquake in Tohoku (Japan) in 2011 – tsunami travelled 10km inland as a result of the earthquake. This damaged the homes of hundreds of thousands of people. There was a severe shortage of houses and people's health in the long run may be affected.

Loss of lives

- **Earthquakes and their associated hazards threaten the lives of people who live in earthquake zones**
- E.g. 7.9 magnitude earthquake in Sichuan (China) in 2008 – 100 000 people died, 374 000 people injured, 15 million people evacuated, 5.39 billion dollars' worth of buildings destroyed, major landslides occurred

Benefits

- Volcanic areas also tend to be earthquake zones as well. So people may stay in these areas for the benefits that the volcanoes can bring, such as income from tourism, fertile soil for agriculture and geothermal energy.
- Hence in order to tap on the benefits brought by the volcanic eruptions, people may adopt an adaptation approach to living in earthquake zones (which tend to coincide with volcanic areas), with preparation measures such as monitoring-devices and risk assessments. These enable them to reduce the impact of the hazards caused by the earthquakes. In a way, they put in more efforts in planning and implementing mitigation measures to ensure that are prepared and alert in times of disaster.

Thus, although earthquakes can bring about many hazards, they can also heighten the awareness and efforts of the people to be prepared as the people are aware of the risks.

Level	Descriptor
L1 (0-3m)	At this level answers will be generalised or with minimal support if any stand were given at all. Reasoning rather weak and expression may be unclear. A basic answer that has little development.
L2 (4-6m)	Disagreement or agreement will be supported by appropriate detail. Or, both agreement and disagreement are considered, but support is patchy so that the answer is not full. Good reasoning and logic in parts of the answer with good expression in places.

		L3 (7-8m)	At this level answers will be supported by sound knowledge. Both agreement and disagreement are considered and well supported. Reasoning is clear and logical with good expression of language.	
2	(a)(i)	<p>The impact of Hurricane Sandy is distributed along the eastern coast of USA, the coast along the Atlantic Ocean.</p> <p>The highest number of people affected by the power failure is in N.J.</p> <p>The highest number of deaths is in New York with 46 deaths.</p> <p>New York also faces the second highest number of impact in the number of people affected by the power failure.</p> <p>Vt. experiences the lowest number of people affected by the power failure.</p> <p>Some Coastal areas such as R.I., Del. Mass., Maine do not record any deaths.</p>		[4]
	(a)(ii)	<ul style="list-style-type: none"> The damaged power lines would cause power outages and this would result in inconvenience to the people when their electrical appliances/communication device fail as their daily activities are disrupted Damage to buildings such as commercial/residential properties OR damage to infrastructure such as roads, bridges require high cost of repairs and some states might face financial issues or be in debt when they are trying to recover from the disaster. Power outages in industries can cause a huge loss of income and economy is affected negatively as businesses cannot be carried out. The loss of income due to damaged crops can affect the source of income of many locals and this might have an adverse effect on their standard of living. 		[4]
	(b)	<p><u>Successes</u></p> <p>Many countries such as Finland and Ireland have met or exceeded the target set to reduce greenhouse gas emissions, slowing down the process of global warming.</p> <p>The Clean Development Mechanism (CDM) gave Certified Emission Reduction (CER) credits to countries which carried out emission-reduction projects in less developed countries, encouraging overall reduction of greenhouse gases in the world.</p> <p>First formal agreement which reflected the first step taken by 11 countries in the world in tackling climate change.</p> <p><u>Limitations</u></p> <p>Not all countries are able to meet their targets of reducing greenhouse emissions from 2008 to 2012 by at least 5% below their 1990 levels, limiting the efforts in slowing down global warming.</p> <p>Lack of penalty for countries such as Denmark, Sweden and UK which exceeded the set targets of reducing the greenhouse gas emissions.</p> <p>The agreement was not ratified by all countries (such as USA which priorities their coal industry) in the world limiting the effectiveness of reducing greenhouse gases.</p> <p>Reserve 2m each for successes and limitations</p> <p>Kyoto Protocol did not make it compulsory for countries with low greenhouse gas emissions to share energy-efficient technology with countries with high greenhouse emissions, limiting the overall reduction in carbon emissions.</p>		[4]
	(c)	<ul style="list-style-type: none"> Between the Tropic of Cancer and Tropic of Capricorn OR 		[5]

	<ul style="list-style-type: none"> • Between 0° and 30° North and South of the equator (30°N and 30°S of the Equator) • In Asia, the largest concentration of countries that experiences Tropical Climate is in <u>South East Asia</u> in countries such as Singapore, Malaysia, Indonesia, Thailand, Myanmar, Laos, Cambodia, Vietnam • In <u>East Asia</u>, Southern part of China has Tropical Climate • And also in <u>South Asia</u> in countries such as India, Bangladesh, Sri Lanka • In the continent of Africa, West, Central and East Africa in countries such as Democratic Republic of Congo and Kenya has Tropical Climate. • In South America, countries such as Brazil, Ecuador and Mexico in Central America lies within the Tropical Climate zone • North East Australia also experiences Tropical Climate 	
(d)	<p>Climate change refers to any long-term change in Earth's climate, or in the climate of a region or city. Small changes in the climate could affect the environment such as leading to increased sea levels, more frequent extreme weather events, reduce the length of the growing season in different regions and sometimes spread of infectious insect-borne diseases. Although these impacts are mostly environmental but they posed great risks to humans too.</p> <p><u>Rise in sea levels</u> One of the impacts of climate change is the rise in sea levels. A warming climate can cause seawater to expand and ice over land to melt, both of which can cause a rise in sea level. This further impact the environment by eroding the habitat of coastal wildlife and animals. At present, over 600 million people worldwide live in areas less than 10 metres above sea level. Two-thirds of the world's largest cities are located in coastal areas. Rising sea level also threatens these low-lying areas and island. For example, the Majuro Atoll in the Pacific Ocean will lose 80% of its land if sea level rises by half a metre. When sea level rises, coastal area will be in danger of being flooded and people will lose their homes and livelihood too.</p> <p><u>Frequent extreme weather</u> Another impact of climate change is more frequent extreme weather events. An extreme weather event is a severe and rare weather phenomenon. Very often such sudden environmental alterations will result in significant economic losses and the loss of lives. One type of extreme weather event is heat wave. Heat waves are 'silent killers' which can kill many people. In August 2003, Europe experienced a heat wave which killed more than 70 000 people.</p> <p><u>Reduce length of growing season</u> Climate change could affect the length of growing season in certain regions. The growing season refers to the period during which the crops can grow. In some places, higher temperature prevents the crops from growing. For example, in the Yunnan province, China, the production of fruits such as apples and cherries, and nuts such as almonds and walnuts is reduced as these fruits and nuts require cool weather conditions. In Canada, the average wheat grain yield has also been reduced. When growing season is affected and food production is reduced, it means lower income and food supply for the people involved.</p> <p><u>Spread of infectious diseases</u></p>	[8]

Climate change can also result in spread of some infectious insect-borne diseases. Climate change could result in increased temperatures and rainfall in various parts of the world. Insects thrive in these favourable conditions. They may lead to the spread of some infectious insect-borne diseases, which are diseases transmitted to human or animals by insects. For example, heavy rainfall may allow mosquitoes to grow in numbers in aquatic habitats, resulting in the spread of malaria and dengue fever. In 2015, Brazil alone reported over 1.5 million cases. The Philippines reported more than 169 000 cases and Malaysia exceeding 111 000 suspected cases of dengue.

The impacts of climate change is not limited only to the environment. Man who are dependent on the environment for survival are most affect economically and socially in the long run when changes in the environment takes places due to climate change. The degree of seriousness of any impact of climate change can be measured by the scale of the impact, such as number of deaths or amount of economic losses. Climate change may cause the spread of insect borne diseases but not everyone who contracts insect-borne diseases will die from it. Hence it is not the most serious impact. Sea level rise and frequent extreme weather events affect more people across the world and cause greater loss of lives and significant economic losses.

Level	Descriptor
L1 (0-3m)	At this level answers will be generalised or with minimal support if any stand were given at all. Reasoning rather weak and expression may be unclear. A basic answer that has little development.
L2 (4-6m)	Disagreement or agreement will be supported by appropriate detail. Or, both agreement and disagreement are considered, but support is patchy so that the answer is not full. Good reasoning and logic in parts of the answer with good expression in places.
L3 (7-8m)	At this level answers will be supported by sound knowledge. Both agreement and disagreement are considered and well supported. Reasoning is clear and logical with good expression of language.

3	(a) (i)	<ul style="list-style-type: none"> • Consumption of all food types has increased except for pulses and starchy roots • Meat and eggs consumption records the highest increase of 180 kcal (1970:70, 2009:250). • Sugars and sweeteners records the lowest increase of 30kcal. (1970:130, 2009:160). • Fish and seafood and milk have the same amount of increase of 50 kcal. Fish and seafood has increased marginally by 50kcal (1970:10, 2009:40) and milk has increased by 50 kcal (1970:90, 2009:40) • Fruit and vegetable consumption has increased by 80kcal (1970:110, 2009:190). • Animal fat has increased by 40 kcal (1970:10, 2009:50). • Starchy roots consumption has decreased more than pulses. Starchy roots has decreased by 70kcal (1970:100, 2009:170) while pulses consumption has decreased by 20kcal (1970:80, 2009:60). 	[5]
	(a)(ii)	<ul style="list-style-type: none"> • Higher disposable income and purchasing power in Asia . Therefore, able to afford to buy more food from most food types . • Population growth is one of the key drivers in the demand of food. Hence, the increase in the consumption of food could be due to the increasing population of Asia. 	[4]

	<ul style="list-style-type: none"> • Due to food price crisis that occurred between 2006 and 2008, staple food such as starchy roots and pulses rose more than other food. Hence, people in Asia could have found that it is more costly to purchase starchy roots and pulses • Migration and globalisation over the years may have resulted in more types of food and cuisines available in Asia and also more fast food outlets, hence allowing food types to increase in demand 	
(b)	<p>Food Programmes provided by United National World Food Programme.</p> <p><u>Responding to Emergencies</u> This is a strategy for the provision of emergency food assistance during wars and natural disasters.</p> <p>(+) Food was successfully delivered to 99.5% of targeted recipients during the 2011 Sudan food crisis.</p> <p>(-) During such emergencies, food prices may be inflated, which results in high costs for the UNWFP.</p> <p>(-) The extent of its assistance may also be limited by how much funds these organisations receive from donors.</p> <p><u>Cash and Voucher Scheme</u> This involves the distribution of cash and vouchers in places where food is available but people are unable to afford it.</p> <p>(+) Cash and vouchers benefit the local economy because beneficiaries spend the money in local markets.</p> <p>(-) Over time, this may create a culture of dependency among beneficiaries.</p> <p><u>School Meals</u> This involves the provision of school meals to provide nutrition for school children.</p> <p>(+) School feeding provides an incentive for enrolment and attendance and can help children learn more effectively.</p> <p>(-) The coverage of these programmes is uneven across countries. In low income countries, only 18% of children receive a daily meal at school, compared to nearly 49% of children in middle income countries.</p> <p>Programmes provided by the World Bank <u>Global Agriculture and Food Security Programme (GAFSP) (2010)</u> GAFSP provides financing to countries that need help in increasing agricultural productivity and assistance to improve food security in specific countries and regions.</p> <p>(+) GAFSP has helped 7.5 million people in 12 countries such as Togo, Rwanda and Nepal.</p> <p>(+) In Rwanda, the GAFSP funded a project in 2010 to reduce soil erosion and improve productivity in hillside agriculture. This has increased potato yields by 7 times and cereal yields by 4 times. In Togo, GAFSP projects have helped farmers increase corn and cassava productions.</p> <p>(-) As the GAFSP relies on funds from donors, these donors may influence how the funds are used to their advantage.</p> <p>(-) The extent of its assistance may also be limited by how much funds they receive from donors.</p>	[5]
(c)	<ul style="list-style-type: none"> o Mostly located in Asia, in particular China, South Korea, India and countries in Southeast Asia. o These countries are located along the Tropic of Cancer, with most countries located between the Equator and the Tropic of Cancer. 	[5]

	<p>Explain physical factors:</p> <p>Climate</p> <ul style="list-style-type: none"> o High temperature above 5 degrees Celsius between Equator and Tropic of Cancer helps increase rates of photosynthesis and seed germination. o High average annual rainfall in these areas of between 1000 and 2500 millimetres also is conducive for growth of rice, which requires a lot of water o These places also can produce a lot of rice as they are mostly warm and with high rainfall throughout the year, with the exception of China, Korea, and India. <p>Type of soil</p> <ul style="list-style-type: none"> o Fertile soil with more clay and rich in nutrients are best for growing rice. o Soils which retain large amounts of water are best for growing rice o Places such as Philippines have volcanic soil, which is highly fertile and suitable for growing of rice. 	
(d)	<p>I disagree with this statement. The intensification of food production can have adverse impacts on the environment such as eutrophication and salinization but these impacts can be mitigated with proper management and sustainable farming.</p> <p>One challenge associated with the intensification of crop production is the effect of chemicals on water and soil quality. The overuse of fertilizers and pesticides causes chemicals to become concentrated in the soil. Overtime, they would seep into groundwater, contaminating it. They may also be washed into water bodies by surface run-off. The chemicals that reach the streams and rivers become nutrients for algae to grow on the surface of the water. This leads to eutrophication, the presence of excess nutrients in water leading to algae bloom. Algae bloom depletes oxygen in the water and block sunlight from reaching aquatic plants, leading to the death of water plants and animals. The decomposition of these aquatic creatures and plants further depletes oxygen in the water. For example in the USA, it was found that pesticides from farmland had contaminated groundwater and this is a serious concern as about 23% of the freshwater used in the country comes from groundwater sources. Thus, the intensification of crop production can affect the environment in a detrimental way.</p> <p>Irrigation can cause problem when not properly managed. Extensive irrigation may cause the ground to be waterlogged when too much water seeps into the soil and causes the soil to be over saturated. This causes the roots to be deprived of air and nutrients that the crops need, eventually causing them to die.</p> <p>Salinisation can also occur when the water added to the soil during irrigation evaporates directly from the moist soil after evaporation. It occurs when there is no proper drainage of excess water. The groundwater may reach the upper soil layers, bringing up dissolved salts from the ground. Saline soils are those in which the concentration of salts is too high for crops to grow well.</p> <p>For example, the problems of water logging and salinization have been observed in Murray-Darling Basin in Victoria, Australia. The naturally occurring salts became concentrated in some parts of the basin due to human activities such as irrigation development. Thus, the intensification of crop production can affect the environment in a detrimental way.</p>	[8]

		<p>However, measures can be taken to ensure that intensification of food can be carried out without harming the environment. Implementing control measures aimed at preventing from reaching water bodies because it is less effective to treat the water bodies once the problem has occurred. As such, measures to manage runoff should be in place.</p> <p>Raising awareness of eutrophication through public campaigns, school environmental education programmes and targeted outreach within communities. Monitoring the pollution level in the environment is a continuous effort that requires cooperation between government, organisation and the community. Thus, I disagree that intensification of food production cannot be carried out without harming the environment.</p>									
		<table border="1"> <thead> <tr> <th>Level</th> <th>Descriptor</th> </tr> </thead> <tbody> <tr> <td>L1 (0-3m)</td> <td>At this level answers will be generalised or with minimal support if any stand were given at all. Reasoning rather weak and expression may be unclear. A basic answer that has little development.</td> </tr> <tr> <td>L2 (4-6m)</td> <td>Disagreement or agreement will be supported by appropriate detail. Or., both agreement and disagreement are considered, but support is patchy so that the answer is not full. Good reasoning and logic in parts of the answer with good expression in places.</td> </tr> <tr> <td>L3 (7-8m)</td> <td>At this level answers will be supported by sound knowledge. Both agreement and disagreement are considered and well supported. Reasoning is clear and logical with good expression of language.</td> </tr> </tbody> </table>	Level	Descriptor	L1 (0-3m)	At this level answers will be generalised or with minimal support if any stand were given at all. Reasoning rather weak and expression may be unclear. A basic answer that has little development.	L2 (4-6m)	Disagreement or agreement will be supported by appropriate detail. Or., both agreement and disagreement are considered, but support is patchy so that the answer is not full. Good reasoning and logic in parts of the answer with good expression in places.	L3 (7-8m)	At this level answers will be supported by sound knowledge. Both agreement and disagreement are considered and well supported. Reasoning is clear and logical with good expression of language.	
Level	Descriptor										
L1 (0-3m)	At this level answers will be generalised or with minimal support if any stand were given at all. Reasoning rather weak and expression may be unclear. A basic answer that has little development.										
L2 (4-6m)	Disagreement or agreement will be supported by appropriate detail. Or., both agreement and disagreement are considered, but support is patchy so that the answer is not full. Good reasoning and logic in parts of the answer with good expression in places.										
L3 (7-8m)	At this level answers will be supported by sound knowledge. Both agreement and disagreement are considered and well supported. Reasoning is clear and logical with good expression of language.										
4	(a)	<ul style="list-style-type: none"> • Type of farming: A is subsistence farming while B is commercial farming. • Purpose: In subsistence farming, the purpose of farming is production of crops to feed farmer and his family, while in commercial farming, the purpose of farming is large-scale production of crops intended for sale, rather than to meet the consumption needs of the farmers or the farmer's livestock (i.e. cash crops) • Land: Subsistence farming uses small (1-3 ha) pieces of land while commercial farming uses large land area (30 ha or more). • Labour: Subsistence farming uses family members of the farmer as labour while commercial farming uses hired labour • Capital: Subsistence farming has lower capital inputs and thus uses simple farming tools and seeds from previous harvests whereas commercial farming has higher capital inputs and thus uses machinery such as tractors and combine harvesters • Crop yield and productivity: Therefore, subsistence farming produces lower crop yield and is less productivity than commercial farming, which produces high crop yield and is more productive. 	[5]								
4	(b)	<ul style="list-style-type: none"> • Relocation diffusion: when a disease spreads to new areas outside its current geographic range, while still being present in the location of origin; it can leap over great distances and intervening populations, less affected by distance; occurs when a community migrates from one place to another • such as the migration of African male workers and the spread of HIV/AIDS • e.g. SARs and its spread in Asia through a doctor who travelled from China to Hong Kong 	[4]								

	<ul style="list-style-type: none"> Expansion diffusion: when an infectious diseases is spread outwards from its source but generally stays in the same region, takes place through contact between people and is strongly affected by distance and more likely to occur when people have contac or interact for example the spread of Malaria between people in Africa 	
(c)(i)	<ul style="list-style-type: none"> The percentage of HIV prevalence in South africa has increased for all ages. <20 years old: 2 -15%, 20-24 years: 2- 29%, 25-29 years: 2-31% From 1991-1997, age group from 20-24 years old records the highest rate of increase from 2-20%. From 1998-2001, the rate of increase for the age group 25-29 years old overtakes that of 20-24 years old. The agre group <20 years old records the lowest rate of change. For all age groups, the highest increase in the percentage of HIV prevalence was from 1997-1998. By 2001, the age group of 25-29 records the highest percentage of HIV prevalence of 31%, followed by 20-24 years old age group and <20 years old age group. 	[3]
(c)(ii)	<ul style="list-style-type: none"> Hardship for those infected and their families – stigma and avoidance from other members of the community. Loss of income and job when a breadwinner or caregiver becomes ill with HIV/AIDS. Economic burden upon family members as ARV treatment is expensive and those affected with HIV/AIDS need nutritious food. AIDS increases the number of deaths (including infant mortality rate) and reduces the life expectancy of people in the country. Trauma of bereavement and orphan crisis – these orphans suffer from the emotional trauma of losing their parents and being stigmatized by society. These children are often assumed to be HIV positive themselves 	[4]
(d)	<p>Individual involvement:</p> <ul style="list-style-type: none"> Individuals can take action to help manage the spread of infectious diseases when they are aware of what these diseases are and the conditions which favour their spread. For example being aware about hand, foot and mouth disease (HFMD) outbreaks in a community could make individuals more mindful about their own hygiene. Individuals may also become more aware of the likely ways the disease can be transmitted. Individuals can exercise social responsibility. Examples of these include being constantly aware of unsanitary conditions or conditions which make it conducive for diseases to spread. This allows individuals to take precautionary measures against infectious diseases. <p><u>Community involvement</u></p> <ul style="list-style-type: none"> Communities can work together to control diseases by introducing possible disease control strategies Deciding when and where strategies will be implemented and by whom and Engaging health workers to train and monitor members <p><u>Government strategies:</u></p> <ul style="list-style-type: none"> Governments are actively involved in managing the spread of diseases by carrying out precautionary measures that aim to prevent 	[8]

outbreaks of diseases. Governments also use mitigation measures to try to reduce the occurrence of an epidemic.

- Governments can implement precautionary measures, which are strategies used to reduce the occurrence of diseases. Examples of these are providing vaccinations against H1N1 and thermal fogging.
- Mitigation measures are strategies that are used to reduce the impact of a disease or health problem, after it has emerged in a country. When an outbreak or epidemic occurs within a country, governments need to respond with mitigation measures. These can include organising the closure of schools and public places during an epidemic. In many cases, it may involve providing health care services as well as requiring doctors to report cases of diseases. For example, Singapore responded to the Sars outbreak in 2003 through control measures such as detecting and isolating infected people in a dedicated hospital, and subjecting potential patients to home quarantine by law.

Involvement by international organisations

- The WHO'S 'Directly Observed Treatment, short-course' address TB among the poor and vulnerable populations, contribute to health system strengthening based on primary health care, engage all care providers, empower people with TB, and communities through partnership, enable and promote research.
- The Joint United Nations Programme on HIV/AIDS (UNAIDS) 'Getting to Zero Strategy'. Their goals to reduce sexual transmission of HIV/AIDS by half, provide universal access to antiretroviral therapy for people living with HIV, and address HIVspecific needs of women and girls.

Conclusion:

- In reality, individual responsibility is indeed the most important factor but also the most difficult goal to achieve, which results in why infectious diseases are so difficult to eradicate. Society is simply too culturally diverse and different groups of people will respond differently to advice, education or to what their authorities advocate – making the idea of everyone being responsible for themselves almost impossible. Being humans in such a complex network, there will always be room for errors and irresponsible ways of living and thus the hopes of eradicating infectious diseases globally remain one of mankind's big challenges.

Class	Index Number	Name
-------	--------------	------

	新加坡海星中学 MARIS STELLA HIGH SCHOOL PRELIMINARY EXAMINATION TWO SECONDARY FOUR
---	--

GEOGRAPHY Paper 1 Additional Materials: Writing paper (4 sheets) 1 Insert	2236/01 21 Aug 2017 1 hour 40 minutes
--	--

<p>READ THESE INSTRUCTIONS FIRST</p> <p>Write your class, index number and name on all the work you hand in. Write neatly in dark blue or black pen. You may use an HB pencil for any diagrams or graphs. Do not use paper clips, highlighters, glue or correction fluid.</p> <p>Section A Answer Question 1.</p> <p>Section B Answer one question.</p> <p>Write all answers on the Answer Paper provided. Candidates should support their answers with the use of relevant examples. Sketch maps and diagrams should be drawn whenever they serve to illustrate an answer. The Insert contains Photograph A for Question 1.</p> <p>At the end of the examination, tie your answer sheets together. The number of marks is given in brackets [] at the end of each question or part question. The total number of marks for this paper is 50.</p>

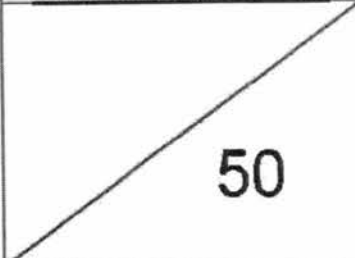
For Examiner's Use

Section A

This question is compulsory.

- 1 A group of students is carrying out a study of how tourism benefits Singapore. To do this, they decided to collect data about visitors to Singapore from other countries, with particular focus on those in South-East Asia. This data was represented using a map and a table, as shown in Fig. 1 and Table 1.
- (a) Fig. 1 is a map that shows flow lines depicting the movement of visitors to Singapore from selected countries in South-East Asia in 2015. Table 1 shows the number of visitors from these countries in 2015.

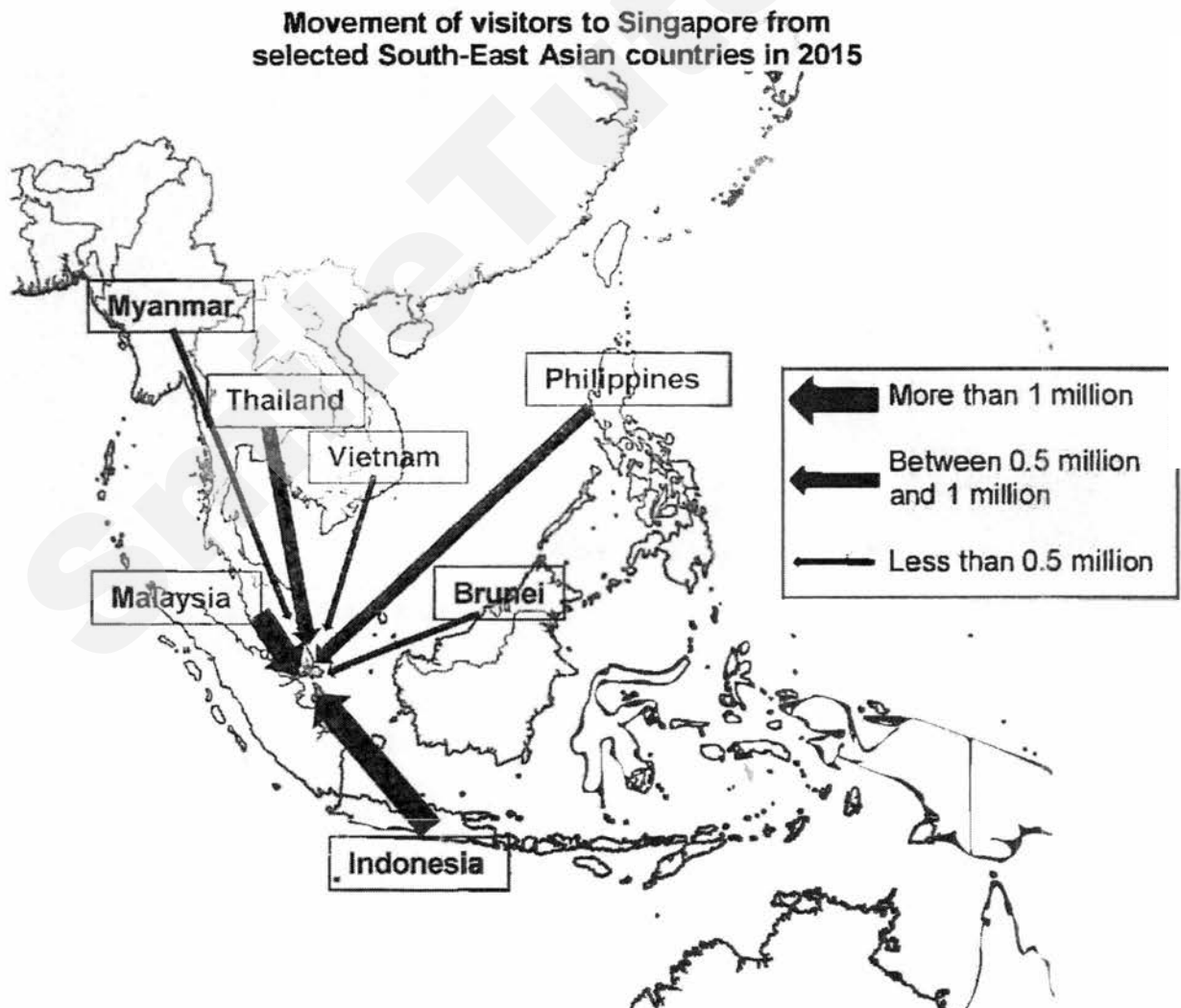

Fig. 1

Table 1

**Number of visitors to Singapore from
selected South-East Asian countries in 2015**

Country	Number of visitors to Singapore in 2015
Brunei Darussalam	73,594
Indonesia	2,731,690
Malaysia	1,171,077
Myanmar	105,452
Philippines	673,374
Thailand	516,409
Vietnam	418,266

(i) Explain why Fig. 1 might be a preferable way of showing the number of visitors. [2]

(ii) Students wanted to test the hypothesis that "The number of tourists from South-East Asian countries that visit Singapore depends on the distance of that country from Singapore".

Based on Fig. 1 and Table 1, to what extent is this hypothesis true? Explain your answer. [4]

(b) In order to learn more about visitors to Singapore, students decided to carry out surveys at Resorts World Sentosa (RWS). They divided themselves into three groups to carry out surveys, using systematic sampling, simultaneously at the following three locations over the course of one afternoon:

- outside the Casino;
- outside Universal Studios Singapore;
- in the Resorts World Convention Centre.

Fig. 2 is a map of Resorts World Sentosa with the survey locations marked with an **X**. At each site, students interviewed 20 visitors.

Comment on the sampling and survey techniques used by the students to carry out their surveys. [6]

4

- (c) As part of their survey of visitors, students collected information about the following:
- age;
 - length of stay in Singapore;
 - whether they were travelling alone or with others.

Explain why it would be important for the students to collect this information about visitors. [4]

- (d) Describe how the students could draw a graph showing the relationship between the age of the visitor and their length of stay in Singapore. [3]

- (e) Suggest and describe methods students could use to test the hypothesis "Visitors to Singapore find Sentosa an enjoyable place to visit" Give examples to support your answer. [6]

5

Section B

Answer one question from this section.

- 2(a) Study Fig. 3, which is a map showing Homer Spit in Alaska, and Photograph A, which is a photograph showing Homer Spit from the air.

Map of Homer Spit

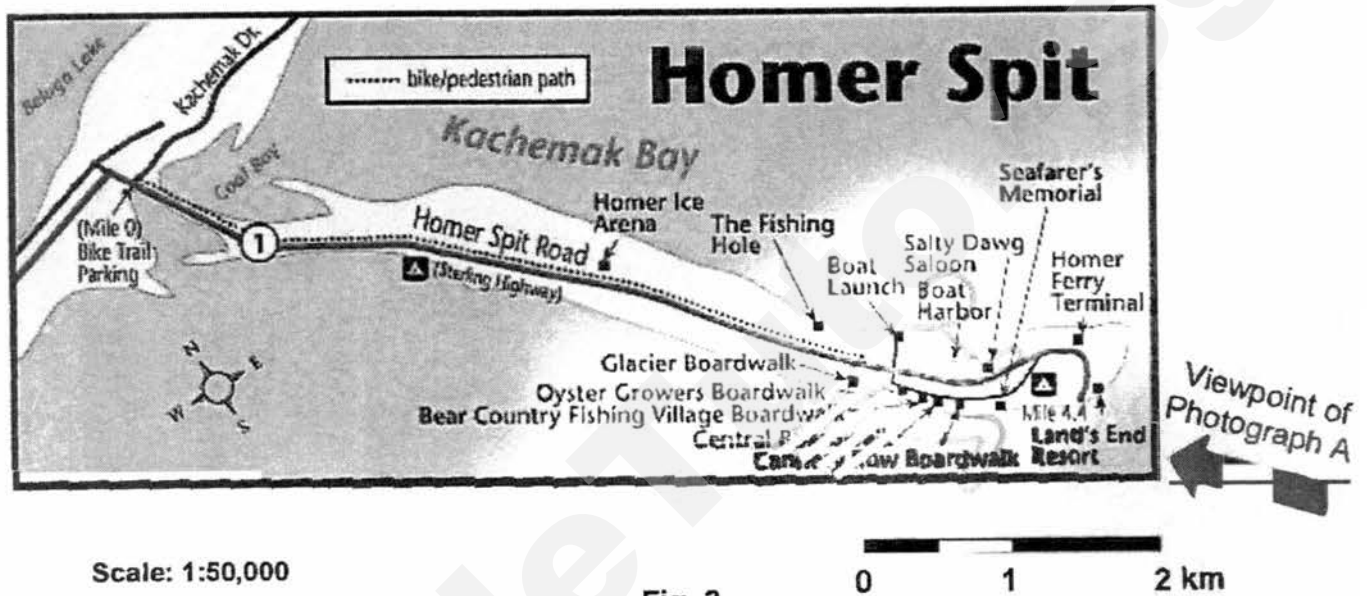
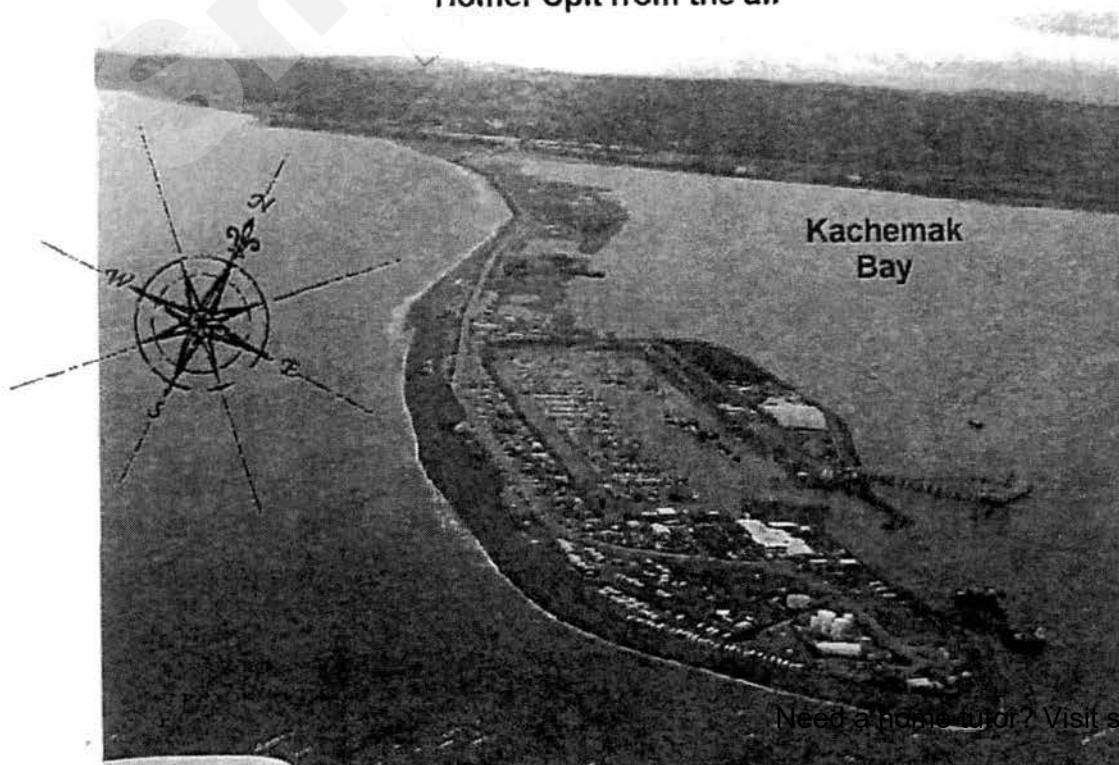

Fig. 3

Photograph A for Question 2

Homer Spit from the air



6

- (i) Use the information contained in Fig. 3 and Photograph A to help you describe the physical and human features found on Homer Spit. [5]
- (ii) Describe how coastal features like Homer Spit can be formed. [3]

(b) Study Fig. 4, which shows threats to coral reefs.

Threats to coral reefs



Fig. 4

- (b) Use Fig. 4 to help you explain threats to coral reefs. [5]
- (c) Explain how laws and regulations can be used to protect coastal areas. [4]
- (d) "Developments in technology have been the main reason for the growth of global tourism."
With reference to examples, assess the accuracy of this statement. [8]

- 3(a) Study Fig. 5, which is a map showing the countries which were the top ten tourist destinations in 2015.

The world's top ten tourist destinations in 2015

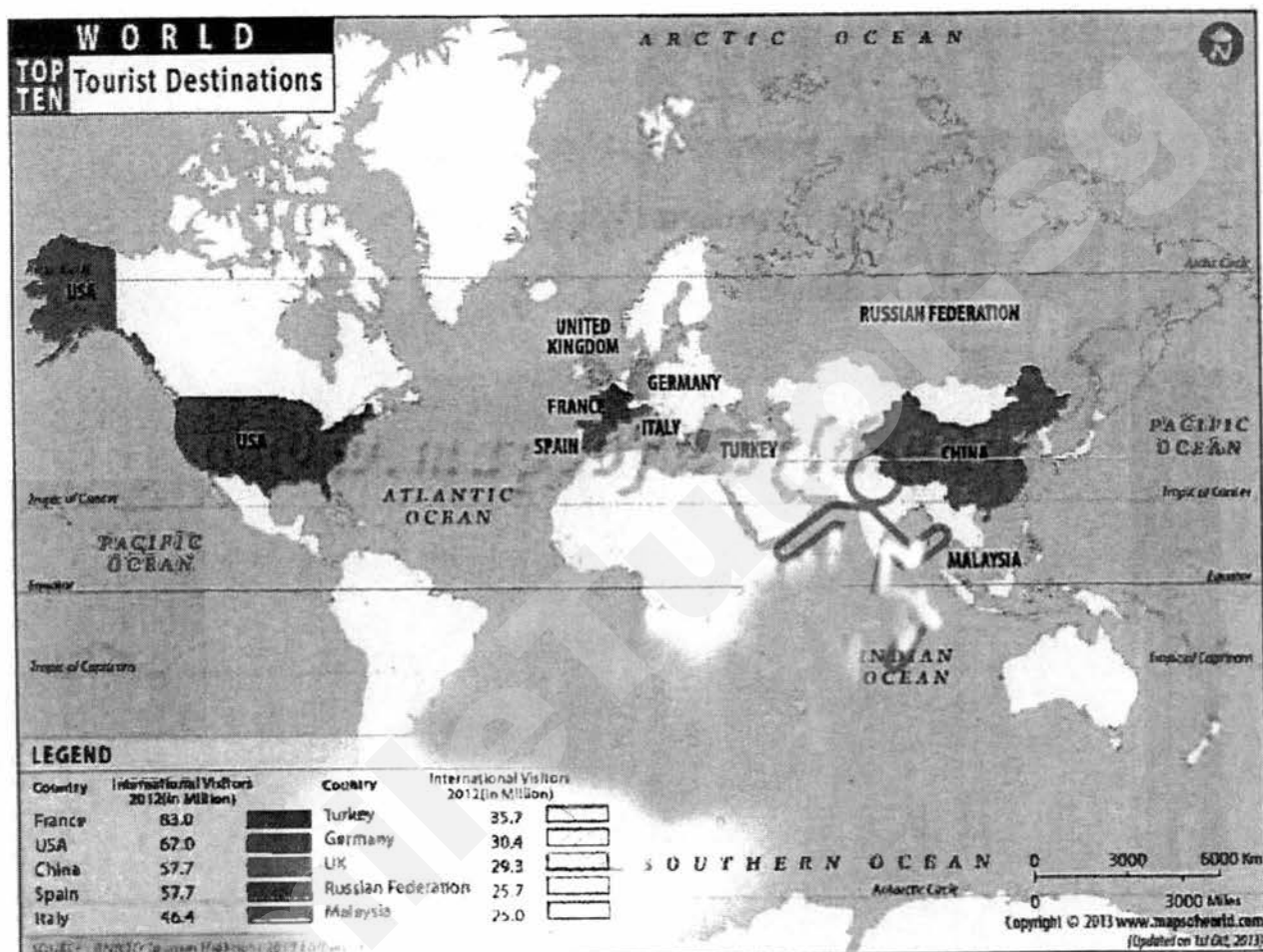

Fig. 5

- (i) Describe the distribution of the world's top ten tourist destinations. [3]
- (ii) With reference to the information shown in Fig. 5, suggest reasons why these countries are able to attract such a large number of tourists. [6]

- (b) Study Photograph B, which shows a war cemetery in France.

Photograph B for Question 3

Photograph of the Souain French National War Cemetery (La Crouée)



With the help of Photograph B, define the term dark tourism and use examples to explain why it can be attractive to tourists. [4]

- (c) With reference to examples, explain how recessions can affect tourism. [4]
- (d) "The benefits of tourism outweigh its disadvantages."
Making use of examples, assess the accuracy of this statement. [8]

SmileTutor.sg

Class	Index Number	Name

	<p>新加坡海星中学 MARIS STELLA HIGH SCHOOL PRELIMINARY EXAMINATION ONE SECONDARY FOUR</p>
---	--

GEOGRAPHY Paper 1	2236/01 21 August 2017 1 hour 40 minutes
Insert	

READ THESE INSTRUCTIONS FIRST
This Insert contains Fig. 2 for Question 1.

This document consists of 2 printed pages inclusive of the cover page.

Class	Index Number	Name
-------	--------------	------



新加坡海星中学
 MARIS STELLA HIGH SCHOOL
 PRELIMINARY EXAMINATION TWO
 SECONDARY FOUR

GEOGRAPHY
Paper 2

2236/02
25 August 2017
1 hour 30 mins

Additional Materials: Writing paper (6 sheets)
 1 Insert

READ THESE INSTRUCTIONS FIRST

Write your class, index number and name on all the work you hand in.
 Write **neatly** in dark blue or black pen.
 You may use an HB pencil for any diagrams or graphs.
 Do not use paper clips, highlighters, glue or correction fluid.

Section A

Answer **one** Question.

Section B

Answer **one** Question.

Write all answers on the writing paper provided.
 Candidates should support their answers with the use of relevant examples.
 Sketch maps and diagrams should be drawn whenever they serve to illustrate an answer.
 The insert contains Fig. 7 for Question 4.

At the end of the examination, tie your answer sheets together.
 The number of marks is given in brackets [] at the end of each question or part question.
 The total number of marks for this paper is 50.

For Examiner's Use

50

2

Section A

Answer one question from this section

1(a) Study Fig. 1, which is a map showing areas in India at risk from earthquakes.

Areas in India at Risk from Earthquakes

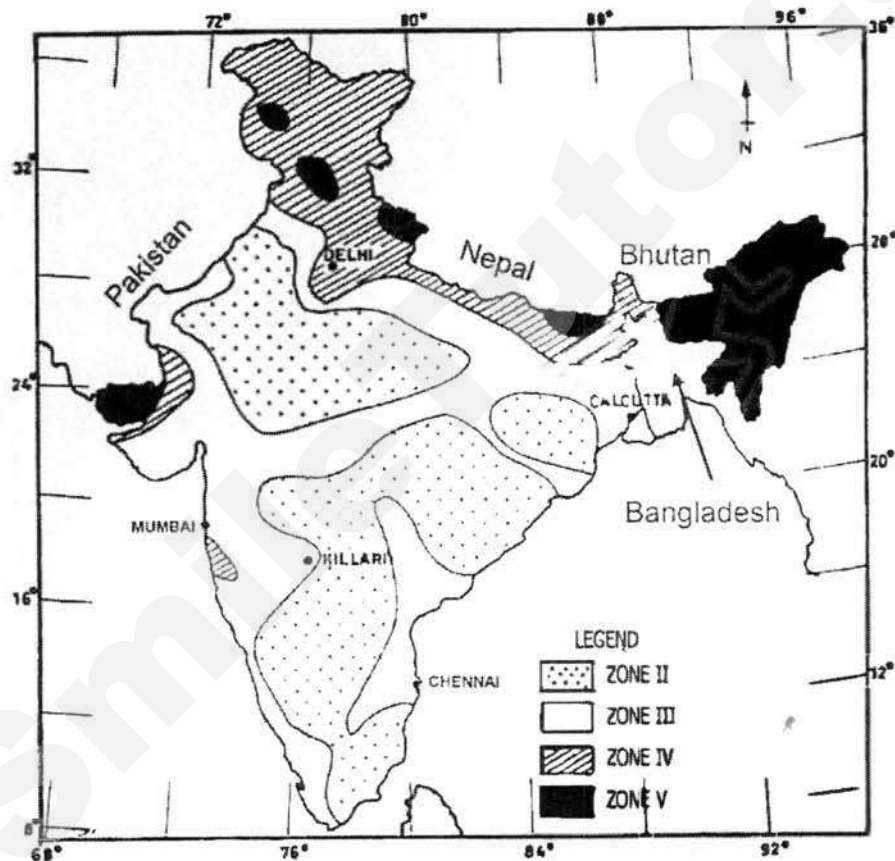

Areas in Zone V are at the highest risk, while Areas in Zone II are at the lowest risk

Fig. 1

Describe the pattern of earthquake risk in India.

[4]

(b) Study Fig. 2, which is a map showing the location of the East African Rift Zone.

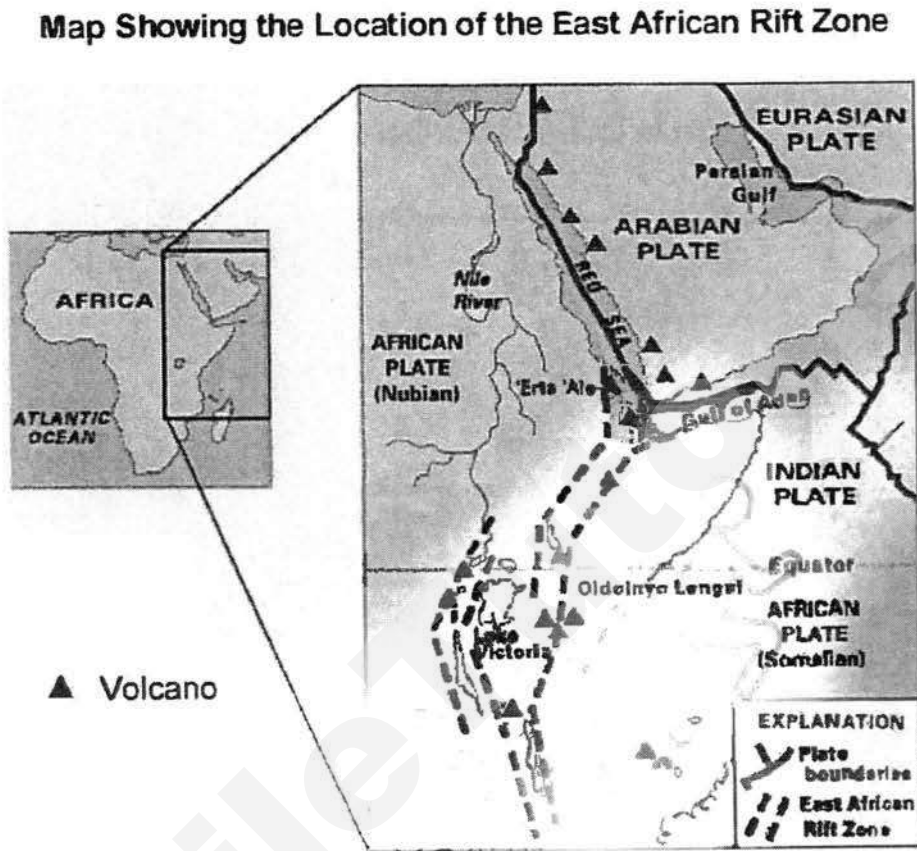

Fig. 2

Using Fig. 2, explain how the East African Rift Zone was formed and suggest why volcanic activity is common in this area. [5]

- (c) Study Photograph A, which shows farmers in Indonesia looking on as a nearby volcano erupts.

Photograph A

Volcano erupting in Indonesia



With the help of Photograph A, explain why people choose to live near volcanoes, despite the risk of doing so. [4]

- (d) Discuss the successes and limitations of long-term responses to earthquakes. [4]

- (e) "Emergency action and mitigation measures are both important when responding to the threat of tropical cyclones."

To what extent do you agree? Discuss with reference to examples. [8]

2(a) Study Fig. 3, which is a typical weather forecast for Singapore, and Fig. 4, which is a climograph for Singapore.

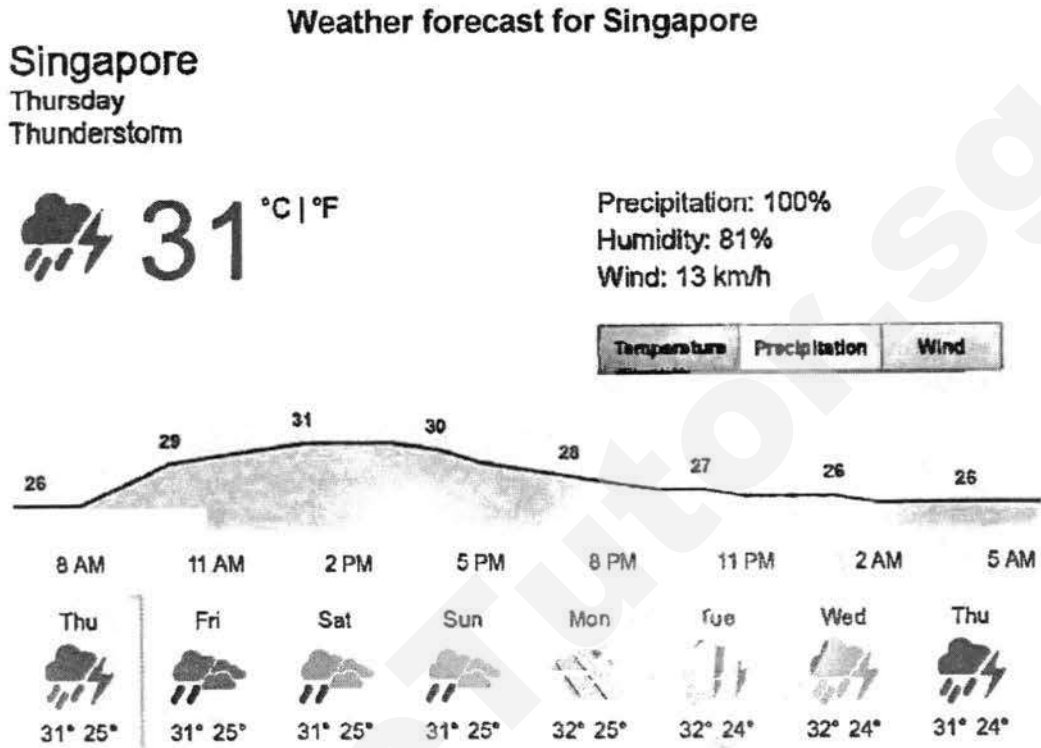

Fig. 3

Climograph for Singapore

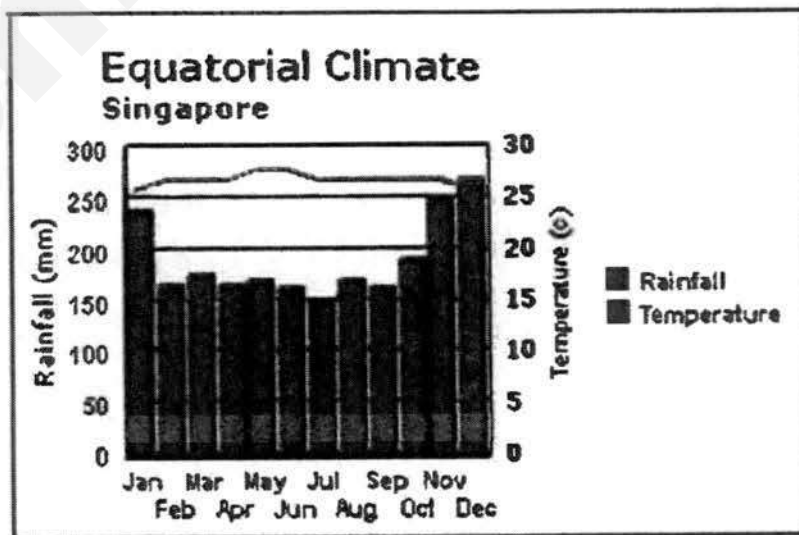

Fig. 4

Using Figs. 3 and 4, account for the climate experienced by the island of Singapore.

6

(b) Study Photograph B, which shows an area affected by a tropical cyclone.

Photograph B

Photograph showing an area affected by a tropical cyclone



Use Photograph B to help you describe the impacts of tropical cyclones.

[4]

- (c) Study Fig. 5, which shows the concentration of carbon dioxide (CO₂) in Earth's atmosphere from 1958 to 2016.

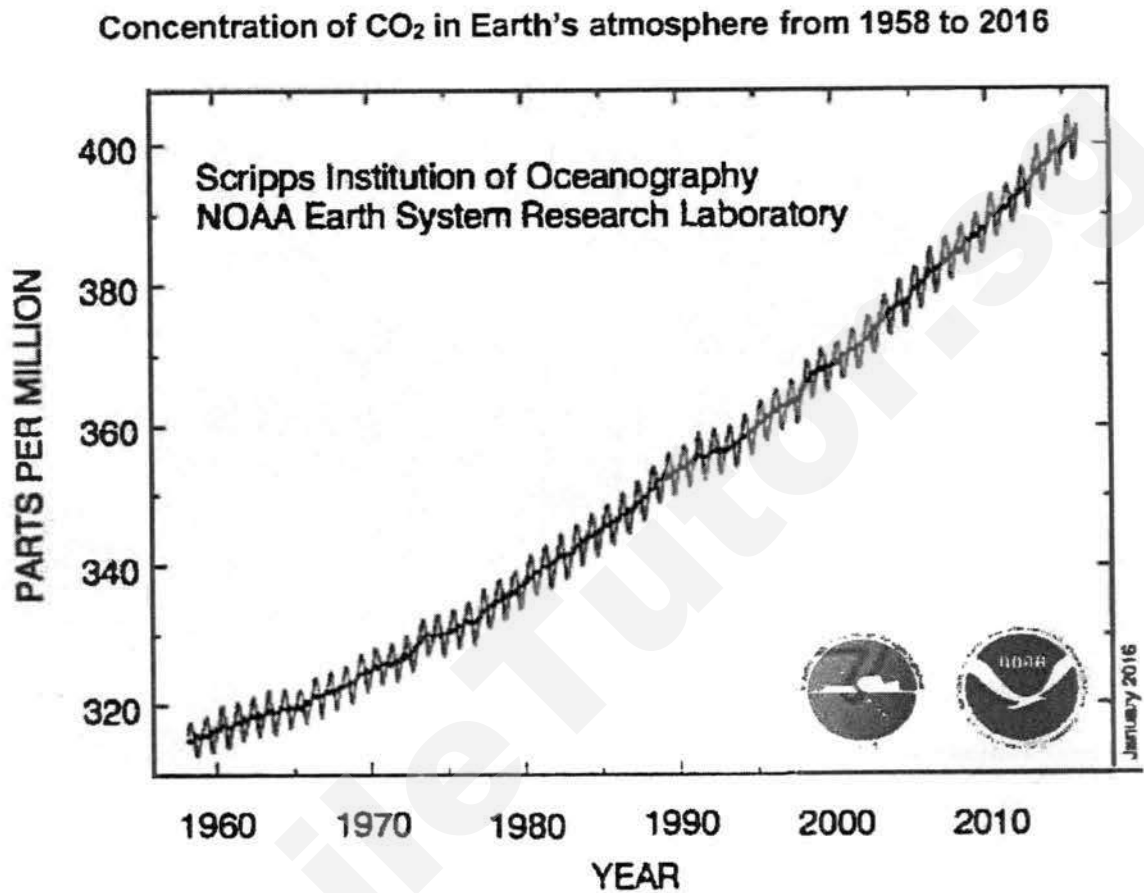

Describe and account for the rise in CO₂ concentrations in Earth's atmosphere from 1958 to 2016. [4]

- (d) Explain how land and sea breezes are formed. [4]

- (e) "The spread of insect-borne diseases is the most serious impact of climate change."

To what extent do you agree? Discuss, with reference to examples. [8]

8

Section B

Answer one question from this section

- 3(a) Study Table 1, which is a table showing the average daily food consumption per capita and the Gross Domestic Product (GDP) per capita of selected countries.

Table 1

**Average daily energy food consumption per capita and
GDP per capita of selected countries**

Country	Average daily food consumption per capita in kilocalories (kcal)	Gross Domestic Product (GDP) per capita in US dollars (US\$)
Austria	3,800	44,498
United States	3,750	57,436
Luxembourg	3,680	103,199
United Kingdom	3,450	40,096
Japan	2,800	38,917
Thailand	2,540	5,899
India	2,360	1,723
Pakistan	2,280	1,428
Haiti	1,850	781
Afghanistan	1,750	561
Burundi	1,680	325
Eritrea	1,590	823

- (i) Describe the relationship between average daily food consumption per capita and the GDP per capita of the countries shown in Table 1. [3]
- (ii) Using examples from Table 1, explain why the average daily food consumption per capita varies greatly from country to country. [4]

- (b) Study Fig. 6, which is a cartoon showing one of the impacts of inadequate food consumption.

Cartoon showing an impact of inadequate food consumption

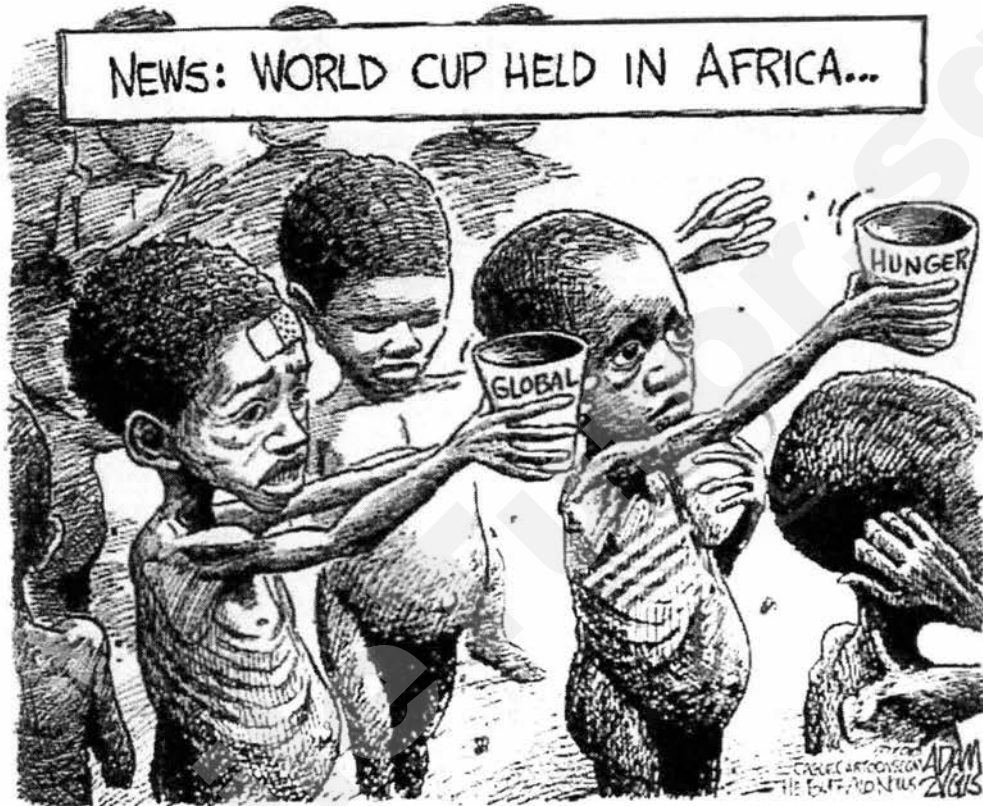

Fig. 6

Use Fig. 6 to help you explain the impacts of inadequate food consumption. [5]

- (c) Explain how poverty can encourage the spread of diseases. [5]

- (d) "The use of technology is the most effective way of overcoming food shortages."

How far do you think this statement is true? Discuss, using examples. [8]

4(a) Study Fig. 7 (Insert), which is map showing the world distribution of malaria in 2014.

Describe and account for the distribution of countries with malaria in 2014. [6]

(b) Study Fig. 8, which is a graph showing the relationship between health care spending per capita and life expectancy of selected countries.

The relationship between health care spending per capita and life expectancy of selected countries

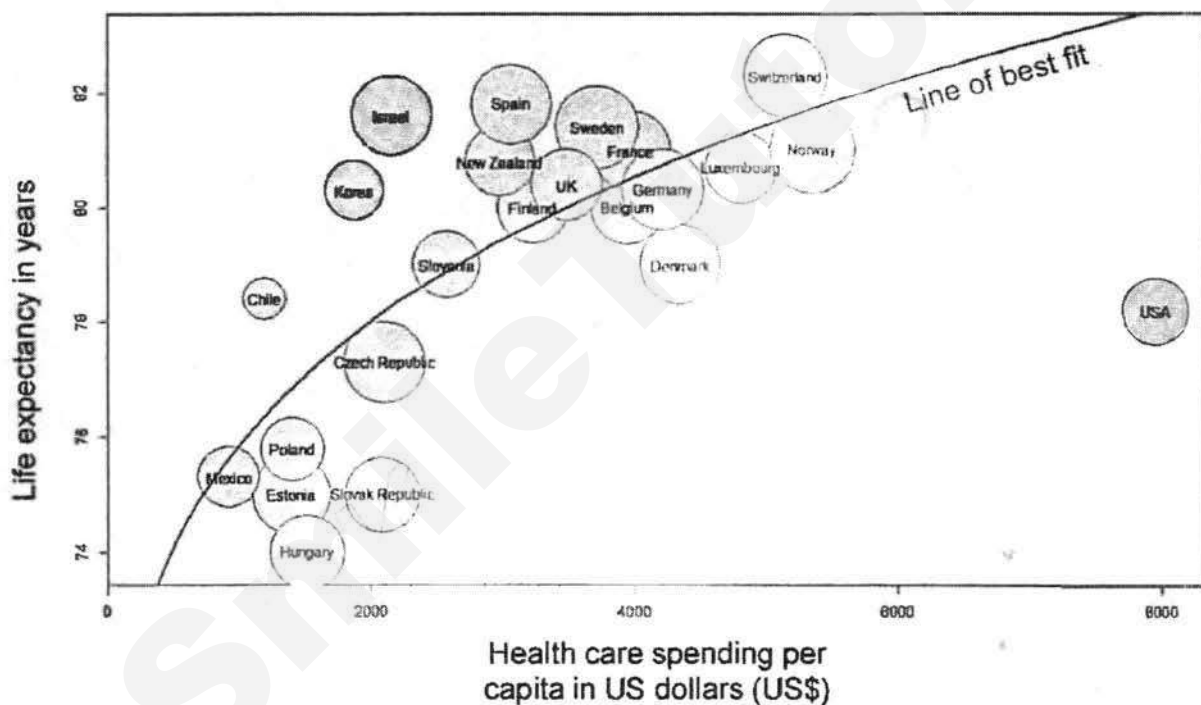

Fig. 8

Describe and account for the relationship between health care spending per capita and life expectancy. [6]

(c) How does HIV/AIDS impact individuals, communities and countries? [5]

(d) "The individual plays the most important role in controlling the spread of HIV/AIDS."

To what extent do you agree? Explain your answer, with reference to examples. [8]

Class	Index Number	Name
-------	--------------	------



新加坡海星中学

MARIS STELLA HIGH SCHOOL
PRELIMINARY EXAMINATION ONE
SECONDARY FOUR

GEOGRAPHY
Paper 2

Insert

2236/02

25 August 2017
1 hour 30 minutes

READ THESE INSTRUCTIONS FIRST

This Insert contains Fig. 7 for Question 4.

This document consists of 2 printed pages inclusive of the cover page.

Maris Stella High School
 Department of Humanities
 Secondary 4 Geography 2017
 Preliminary Examination 2 (Paper 2)
 Suggested Answers

General note: All answers are to be written in complete sentences and paragraphs. No answers in point form will be marked.

1(a)(i) In what ways is Fig. 1 a preferable way of showing the number of visitors?
 Give reasons for your answer

[2]

- The flow lines on the map in Fig. 1 make it easy to visualise the relative number of visitors from each country as the thickness of the line varies with the number.
- The map also makes it easy to visualise the relative location of Singapore in South-East Asia and the distances that tourists must travel to reach it.

1(a)(ii) Students wanted to test the hypothesis that 'The number of tourists from South-East Asian countries that visit Singapore depends on the distance of that country from Singapore'. Based on Fig. 1 and Table 1, to what extent is this hypothesis true? Explain your answer.

[4]

- The hypothesis is only true up to a point. (Reserve 1 mark)
- The largest number of tourists do indeed come from the nearest countries, Malaysia and Indonesia.
- However, the countries with 0.5 million to 1 million category visitors to Singapore, Thailand and the Philippines are both fairly distant and only Myanmar is farther away.
- Also, some countries with the least visitors to Singapore, Brunei and Vietnam are not that far away from Singapore. Only Myanmar, with few visitors, is also rather far from Singapore.

1(b) Comment on the technique used by the students to carry out their surveys.

[6]

- Using systematic survey techniques is a practical solution to interviewing visitors and helps to prevent bias in the results.
- The locations that students chose would give them access to different types of visitors:
 - visitors to the Casino would be adults attracted by the gambling;
 - the Universal Studios Singapore would attract visitors of all ages, including families with children;
 - the Resorts World Convention Centre would attract business tourists and meetings, incentives, conventions and exhibition (MICE) tourists.
- However, the students should have divided themselves into more groups so that they could also conduct surveys at places such as the hotels so as to get a wider range of respondents.

- They should have also picked other locations such as the South East Asia Aquarium or the museums to be able to get feedback from visitors interested in those facilities.
- Students should also have conducted surveys over the course of several days and at different times of days in order to get more reliable and accurate data.
- They should have also interviewed a larger number of tourists so as to get a statistically more accurate sample.

1(c) Explain why it would be important for the students to collect this information (age, length of stay in Singapore and whether they were travelling alone or with others) about visitors. [4]

- The information about age would allow student to see if the Resorts World Sentosa (RWS) was more attractive to younger or older people, as many of the attractions, e.g. the casino or the Universal Studios Singapore would be appealing only to specific age groups of people
- Information about the length of stay in Singapore would allow students to gauge the attractiveness of Singapore as a tourist destination as people would stay here longer if there more attractions for them to visit
- Information about whether visitors were travelling alone or with their family would give the students an idea whether they are many business travellers, who are more likely to travel alone
- On the other hand, travellers who travel with others may be travelling with their families on a family holiday or with colleagues on an incentive trip, or with friends. This would give more information about the types of visitors to Singapore.

1(d) Describe how the students could draw a graph showing the relationship between the age of the visitor and their length of stay in Singapore. [3]

- The students could draw a scatter-plot graph to represent the data and show the relationship between the age of visitors and their length of stay in Singapore.
- They could draw a graph with one axis showing the age and the other showing the length of stay and plot the data collected from each survey individually.
- Once all the data has been plotted, they could draw a line of best fit to show the relationship between age and length of stay.

1(e) Suggest and describe methods students could use to test the hypothesis "Visitors to Singapore find Sentosa an enjoyable place to visit." Give examples to support your answer. [6]

Suggesting a method (2 marks)

- The students could make use of a bipolar survey to get feedback from visitors.
- The bipolar survey would include questions about how enjoyable the experience of visiting Sentosa was to visitors

Sample questions as examples (3 marks, depending on the quality of the question)

- For example, the students could ask visitors to rate their experience of visiting Sentosa on a scale of 1 to 5, with 1 being "Not enjoyable at all" and 5 being "Very enjoyable".
- Other questions could include "Would you recommend Sentosa to your friends or relatives?", with 1 being "Would definitely not recommend" and 5 being "Would definitely recommend"

Testing the hypothesis (1 mark)

- Students would then compile the data and find the average score for each question, with higher scores indicating a more enjoyable experience of visiting Sentosa, thereby making the hypothesis true.

2(a)(i) Use the information contained in Fig. 3 and Photograph A to help you describe Homer Spit.

[5]

- Homer Spit extends from the mainland in a south-east direction.
- It is about 6.75 km long.
- The spit does not extend into the sea in a straight line but curves slightly.
- At the point where the spit is attached to the mainland it is quite narrow but it becomes broader further out to sea.
- There is a road (the Sterling Highway) from the mainland running the length of the spit and connecting it to the mainland.
- There are many buildings, such as the Land's End Resort, built on the spit near the road.
- On the eastern side of the spit (facing Kachemak Bay), a breakwater has been built to shelter a boat harbour behind it.
- There are a few piers on the eastern side of the spit.
- There is evidence of land reclamation on the north-eastern side of the spit adjacent to the boat harbour.

2(a)(ii) Describe how coastal features like Homer Spit can be formed. [3]

- Spits can be formed by longshore drift, which transports sediments along a coast.
- If longshore drift occurs along a coast and the coastline suddenly changes direction and bends away, the longshore drift will carry on in the same direction as before.
- When this happens, the sediments are deposited in the sea after the bend and when there are enough sediments, they will eventually emerge out of the sea to form a spit.

2(b) Use Fig. 3 to help you explain threats to coral reefs. [5]

- Coral reefs face many threats. Firstly, they are affected by oil spills, which can cut-off sunlight and smother corals with toxic oil.
- Secondly, they are affected by coastal development such as land reclamation for the building of ports and tourist resorts.
- Thirdly, they are affected by runoff from agriculture that contains toxic pesticides that can poison corals or fertilisers that can cause eutrophication and cut-off sunlight, which corals need.

- Next, they can suffer from fishing as nets used by fishing boats can rip apart and damage coral reefs.
- Extreme weather events like hurricanes and sea spouts can create huge waves that hit coral reefs and damage them.
- Climate change and rising sea levels can also affect corals as the water gets too warm for them to survive and they undergo coral bleaching.
- In some regions, fishermen use dynamite to stun and capture fish, but this also damages the coral reefs as well.
- Other fishermen use the technique of spear fishing, which allows them to target specific types of fish, which can affect the balance of the coral reef ecosystem.
- Finally, the collection and harvesting of corals from the reef can lead to long-term damage as the reef takes a long time to grow and recover.

2(c) Explain how laws and regulations can be used to protect coastal areas. [4]

- Laws and regulations can be used to protect coastal areas in several ways. Firstly, laws can be passed to limit damaging activities such as dynamiting or harvesting corals, which would help to protect coral reefs.
- Secondly, development of coastal areas could be prevented by law, which would allow these areas to remain unspoiled and untouched.
- Next, marine reserves could be established to protect marine creatures living in them from fishing activities.
- Also, coastal sand dunes could be fenced off and vegetation planted on them to protect them from trampling and erosion.
- Governments could also pass laws to protect coastal areas by building engineering structures like sea walls and breakwaters to protect the coast from erosion.

2(d) "Developments in technology have been the main reason for the growth of global tourism." With reference to the reasons for global tourism growth, assess the accuracy of this statement.
[8]

General thrust of the question

- The key idea behind the question is for candidates to describe and assess the various reasons for the growth of global tourism.
- Candidates should be able to describe and explain how each factor contributed to the growth of global tourism.
- They should also be able to support their answers with clear and specific named examples.
- For their conclusions, candidates should be able to weigh the relative impact of each factor and its contribution to the growth of global tourism.
- Candidates should be able to describe and explain the reasons for the growth of tourism.
- They should be able to explain how each factor has led to the growth of global tourism.
- For their conclusions, candidates need to be able to assess each impact of each factor that leads to the growth of global tourism and assess which has the most impact.

Level descriptors

Level 1 (1 – 3 marks)

- Vague description of one or more factor only.
- No specific named examples or only vague examples provided.
- No attempt made to compare the relative impact of each factor.
- Answer is vague and is not well developed.

Level 2 (4 – 6 marks)

- Clear description of one or more factors with contribution to the growth of global tourism explained clearly.
- Clear and specific named examples for each factor cited.
- Some attempt may have been made to draw a conclusion as to why any one of the factors contributes more to global tourism.

Level 3 (7 – 8 marks)

- Clear description of least two factors with its impacts on global tourism explained clearly.
- Clear and specific named examples for each factor cited.
- A well-reasoned conclusion is drawn that argues why one of the factors contributes more to the growth of global tourism.
- Overall, the answer must be clearly explained, backed up by sound knowledge, with the factors and explanations well-supported with examples.

3(a)(i) Describe the distribution of the world's top ten tourist destinations. [3]

- The world's top ten tourist destinations are all located in the northern hemisphere.
- Europe has the largest number of these countries, while a few, such as China and Malaysia, located in Asia, and one, the United States, located in North America.
- However, none of them are located in Africa, South America and Australasia.

3(a)(ii) Suggest reasons why the countries in Fig. 4 are able to attract such a large number of tourists. [6]

- Countries like the United States, United Kingdom and China have places of scenic beauty and beautiful natural landscapes that can attract honeypot tourism.
- Most of the countries shown in Fig. 4 are developed countries which have good facilities for the hosting of meetings, incentives, conventions and exhibitions, and this can attract business tourists.
- They also have good medical facilities and can therefore also host medical tourists.
- Countries like the United States, France and China have many theme parks like Disneyland that can attract tourists.
- European countries like France and Italy have historical landmarks and buildings that attract tourists who want to learn more about their history.

- Many films have also been made in countries like the United States, the United Kingdom and France, and so people who want to visit the places where the films were made would visit these countries.
- Some people may visit countries like Italy for religious reasons as the Vatican City is located within its capital city of Rome.
- Places like Germany may have dark tourism sites like war memorials or cemeteries dating from the Second World War that may attract tourists interested in history.
- Places like Turkey and Malaysia may attract tourists drawn by their rich culture and traditions.
- Some tourists may go to major cities such as Paris or London to shop or to wine and dine.
- Tourists on a smaller budget may want to visit countries like Malaysia, where things are relatively cheap compared to more developed countries.

3(b) Using Photograph B to help you, define the term dark tourism and use examples to explain why it can be attractive to tourists. [4]

- Dark tourism involves travel to places that are associated with death and tragedy.
- Places like the war cemetery shown in the photograph may be visited by relatives or the descendants of the soldiers buried there.
- Some tourists visit dark tourism sites like battlefields to understand how wars were fought and to experience the lives of the soldiers. For example, the Cu Chi tunnels in Vietnam give visitors a glimpse into the lives of Vietnamese soldiers who fought in the Vietnam War. (Another example is Bukit Chandu in Singapore, which commemorates the Battle of Pasir Panjang Ridge.)
- Places where terrorist attacks took place, like Ground Zero in New York are visited by tourists to remember and reflect on those who lost their lives.
- Places where atrocities took place, such as the Nanjing Massacre Memorial Hall are visited by tourists who want to learn more about history.
- Places where genocides took place, like the Tuol Sieng Genocide Museum in Phnom Penh, Cambodia, allow people to learn more about the suffering of people during wartime.
- Prisons and concentration camps like Auschwitz in Poland and the Changi Prison Chapel in Singapore teach us historical lessons about man's inhumanity and counsel us to avoid making the same mistakes.

3(c) With reference to examples, explain how recessions can affect tourism. [4]

1 mark reserved for a named example

- Recessions like the Global Financial Crisis and the European Sovereign Debt Crisis can affect tourism in various ways.
- Firstly, because many people would have lost money due to these events, they would have less money to travel and this would lead to a drop in international travel.
- Even if tourists are able to afford a holiday, they may spend less while on holiday compared to before, leading to reduced revenues from tourism.

18

- This drop in tourism earnings may lead to a fall in earnings for tourism destinations and even increased unemployment due to loss of jobs.
- Some tourists may choose to take a short-haul flight instead of a long-haul flight and travel to a nearby country in order to save money.
- Other tourists may switch to budget airlines in order to save money.
- Tourists may even choose to travel domestically instead of internationally so as to save money.

3(d) "The benefits of tourism outweigh its disadvantages" Making use of examples, assess the accuracy of this statement.
[8]

General thrust of the question

- The key idea behind the question is for candidates to describe and assess the benefits and disadvantages of tourism.
- Candidates should be able to describe and explain both the benefits and disadvantages of tourism in terms of their impact on the host country.
- They should also be able to support their answers with clear and specific named examples.
- For their conclusions, candidates should be able to weigh the relative impact of the benefits and disadvantages and come to a conclusion as to whether the benefits outweigh the disadvantages.
- Candidates should be able to describe and explain both the benefits and the disadvantages of tourism.
- They should be able to explain how tourism has led to both positive and negative economic, socio-cultural or environmental impacts.
- For their conclusions, candidates need to be able to assess whether the positive impacts of tourism outweighs the negative impact and come up with an explanation of why they believe this to be so.

Level descriptors

Level 1 (1 – 3 marks)

- Vague description of one or more benefits or disadvantages only.
- No specific named examples or only vague examples provided.
- No attempt made to compare the relative impact of benefits and disadvantages.
- Answer is vague and is not well developed.

Level 2 (4 – 6 marks)

- Clear description of one or more benefits and disadvantages with its impacts explained clearly.
- Clear and specific named examples for each benefit and disadvantage cited.
- Some attempt may have been made to draw a conclusion as to the relative impact of benefits and disadvantages of tourism.

Level 3 (7 – 8 marks)

- Clear description of least two benefits and disadvantages with its impacts explained clearly.
- Clear and specific named examples for each benefit and disadvantage cited.

19

- A well-reasoned conclusion is drawn that argues why either benefits or disadvantages have a bigger impact.
- Overall, the answer must be clearly explained, backed up by sound knowledge, with the benefits, disadvantages and explanations well-supported with examples.

SmileTutor.sg

Maris Stella High School
Department of Humanities
Secondary 4 Geography 2017
Preliminary Examination 2 Paper 2
Suggested Answers

General note: All answers are to be written in complete sentences and paragraphs.
No answers in point form will be marked.

1(a) Describe the pattern of earthquake risk in India. [4]

Award 1 mark for each clearly described location of high or low risk

- A large area in the north-east of the country between Bhutan and Bangladesh is at the highest risk level of Zone V.
- A smaller area in the far western side of the country near Pakistan is also at the highest risk level.
- The northern part of India around Delhi and Nepal is mostly at the Zone IV risk, with small areas of Zone V risk level.
- An area in the west near Pakistan and along the coast south of Mumbai are also at Zone IV risk level.
- The central and southern parts of the country are mostly at lower risk levels of Zone II and Zone III.

1(b) Using Fig; 2, explain how the East African Rift Zone was formed and suggest why volcanic activity is common in this area. [5]

Formation of the East African Rift Zone

- The East African Rift Zone was formed when the African Plate (Nubian) and the African Plate (Somalian) began to diverge from each other.
- As the two continental plates begin to move apart, the tensional forces cause the continental plate at the plate boundary to crack and fault.
- If two parallel faults form, the central block between them will sink downwards, forming the rift zone.

Why volcanic activity is common

- The thinning and faulting of the continental plate allows magma from the mantle to escape, causing volcanoes to form.
- Rift valleys like the East African Rift Zone form at places where large amounts of rising magma from the mantle reaches the crust and pushes the plates apart, creating an abundant source of magma and lava to form volcanoes.

1(c) With the help of Photograph A, explain why people choose to live near volcanoes, despite the risk of doing so. [4]

- The first reason people live near volcanoes is that the volcanic ash from eruptions forms fertile soil that allows them to grow crops and obtain high yields.
- Secondly, some volcanic areas contain precious stone and minerals such as diamonds that can be mined and sold by people living in the area for profit.

- Thirdly, volcanic areas such as Mount Fuji can be major honeypot attractions for tourists, which can contribute to the economy of the local area.
- Lastly, geothermal energy can be obtained from the underground heat in volcanic areas, thus benefitting people who live nearby.

1(d) Discuss the successes and limitations of long-term responses to earthquakes. [4]

Rebuilding infrastructure

- Rebuilding of infrastructure can be successful as the new buildings can be built to stricter building codes and made more resistant to future earthquakes.
- However, buildings that are built to resist the impact of earthquakes may not necessarily be resistant to tsunamis and may require additional protection such as coastal walls and breakwaters.
- Also, such buildings are expensive and time-consuming to construct and the rebuilding process may take many years to complete.

Provision of health care

- Health care can be provided to victims of the earthquake to treat long-lasting physical injuries or mental trauma. This will help the victims to overcome their injuries and to come to terms with the depression or anxiety caused by mental trauma so that they can get on with their lives.
- However, long-term health care can be challenging and costly for both the government and the individual.

1(e) "Emergency action and mitigation measures are both important when responding to the threat of tropical cyclones."
To what extent do you agree? Discuss with reference to examples. [8]

General thrust of the question

- Candidates should be able to explain the different measures used to respond to tropical cyclones and be able to explain the benefits and limitations of these measures.
- They need to be able to explain at least one emergency action measure and one mitigation measure.
- They should also be able to support their answers with clear and specific named examples.
- For their conclusions, candidates should be able to weigh the relative benefits and limitations of each response and reach a conclusion as to which is the best using clearly explained criteria (time frame, cost, impact or cause and effect).
- Candidates should be able to describe and explain the responses to tropical cyclones.
- They should be able to explain the benefits of the response, either in reducing the damage caused by cyclones, or by reducing the risk of death or injury.
- They should be able to show that both emergency response measures and mitigation measures play an important role in reducing the impacts of tropical cyclones.
- For their conclusions, candidates need to be able to explain that each measure address one area of vulnerability, e.g. floodplain management helps to protect people living near the coast, while land use control protects people living near rivers.
- For maximum marks, candidates should be able to show that for each set of measures to be at their maximum effectiveness, they need to be complemented by measures of the other set.

- For example, for the emergency action of evacuation to be most effective, the mitigation action of prediction and warning needs to be taken in order to accurately predict the path of cyclones and send out early warnings to people who are at risk to evacuate in time.
- Similarly, one mitigation measure is the floodplain masterplan, which maps out evacuation routes for people living near the coast to move inland away from storm surges. For this measure to be most effective, emergency shelters must be built and emergency drills be carried out so that people have shelters to go to and know how to get to them quickly.

Level descriptors

Level 1 (1 – 3 marks)

At this level, answers will lack detail and may be general in nature. A basic answer that has little development. There may be no or little attempt at assessment of strategies. Examples may or may not be given.

Indicators:

- Vague description of the role of one or more responses only.
- No specific named examples or only vague examples provided.
- No attempt made to compare the relative benefits or limitation of each response.
- Answer is vague and is not well developed.

Level 2 (4 – 6 marks)

At this level answers will contain some appropriate detail. The content will lack balance and some relevant details. This means that only benefits and limitations of the strategies are considered, but support is patchy so that the answer is not fully explained. Assessment may be given but may be general in nature. An example will be presented to support answers in at least once in the answer.

Indicators:

- Clear description of one or more responses, with successes and limitations (pros or cons) explained clearly.
- Clear and specific named examples for at least one of the measures cited.
- Some attempt may have been made to draw a conclusion as to relative effectiveness of the measures.

Level 3 (7 – 8 marks)

At this level, answers will be comprehensive and supported by sound knowledge. There will be assessment of the extent to which set of measures was more successful, i.e. considering both the benefits and limitations of each set of measures. Examples to support answers can be found in most places of the answer. Also, candidates can argue which measure is more effective than the other

Indicators:

- Clear description of least two responses, with successes and limitations (pros and cons) explained clearly
- Clear and specific named examples for each measure cited.
- For L3/7, the candidate needs to be able to see that the measures address different aspects of the threats posed by tropical cyclones.

- For L3/8, a well-reasoned conclusion is drawn that argues how the measures are complimentary and need to be taken together in order for them to be at their maximum effectiveness.
- Overall, the answer must be clearly explained, backed up by sound knowledge, with both sides of the argument considered and well-supported with examples.

2(a) Using Figs. 3 and 4, account for the climate of the island of Singapore. [5]

Award 1 mark for each point

- The weather of Singapore is affected by its latitude. Since Singapore is near the equator, solar energy is more concentrated on Singapore, and the mean temperature of 27°C year-round is high throughout the year.
- Singapore is a low-lying island, so temperatures will remain high compared to places at high-altitude.
- As Singapore is an island the surrounding sea will help to keep temperatures here cooler compared to places that are further inland.
- The amount of cloud cover in Singapore tends to be high, so temperatures tend to be cooler than normal in the day, but higher than normal at night as clouds trap heat and prevent it from escaping into space.
- Singapore has a high relative humidity due to the high rainfall of more than 2000 mm a year and its proximity to the surrounding sea.
- Precipitation (rainfall) in Singapore is high at more than 2000 mm because of the frequent occurrence of convective rain and the high temperatures that allow convective rain to occur.
- During the months of November to January, rainfall is even higher than normal due to the effects of the north-east monsoon, which brings moisture to Singapore from the South China Sea, which it forms clouds and falls as convective rain.

2(b) Use Fig. 6 to help you describe the impacts of tropical cyclones. [4]

Award 1 mark for each point

- Tropical cyclones have physical impacts such as the destruction of and damage to buildings and property shown in Fig. 5 that may cause people to become homeless or businesses to close down.
- They can also damage critical infrastructure like roads, bridges, water pipelines, electricity cables that can cut-off transport and essential services.
- Cyclones can also have economic impacts as the damage they cause to infrastructure and property may be very costly to repair.
- Cyclones may cause crops to be flooded and damaged. This may cause farmers to face financial hardship.
- Should the cyclone destroy food crops on a large-scale, food shortages and famine may occur.
- The strong winds and heavy rain associated with cyclones may disrupt air transport and cause delays, loss of revenue and inconvenience.
- Torrential rain and storm surges that are caused by cyclones may flood low-lying areas, causing massive damage to property and even trap and drown people.
- The heavy rain associated with cyclones may cause landslides and trap and kill people living in mountainous areas.

2(c) Describe and account for the rise in CO₂ concentrations in Earth's atmosphere from 1958 to 2016. [4]

Describe the CO₂ concentration

- The amount of CO₂ in the atmosphere increased gradually from 315 parts per million in 1958, to just over 400 parts per million in 2016.
- The CO₂ concentration fluctuates annually but there is an overall increasing trend. From the year 2000, the rate of increase has increased slightly.

Account for the rise in the CO₂ concentration

- The concentration of CO₂ has increased because of our use of fossil fuels for cars, aeroplanes and other forms of transport.
- deforestation as trees which would have absorbed CO₂ have been felled and can no longer act as the green lungs of the Earth.
- Agriculture has also led to increased CO₂ concentration as farm machines like tractors and farm inputs like fertilisers release CO₂ into the atmosphere.
- Industries release large amounts of CO₂ into the atmosphere due to manufacturing processes and their use of fossil fuels for energy.
- Urbanisation has also led to increased levels of CO₂ as cities tend to use more energy and produce more fossil fuels than compared to rural areas.

2(d) Explain how land and sea breezes are formed. [4]

- Sea breezes form during the day when solar energy heats the land up faster than the sea. This causes air over the land to heat up as well and rise, forming a zone of low pressure. At the same time, air over the sea will sink, forming a zone of high pressure.
- Air will then move from the high pressure zone over the sea to the low pressure zone over the land, thus forming a sea breeze.
- At night, the land cools down faster than the sea, which retains heat better. As a result, the air over the sea heats up and rises while the air over the land is cooled down and sinks.
- This creates a zone of high pressure over the land and a zone of low pressure over the sea. Air thus moves from the land to the sea, forming a land breeze.

2(e) "The spread of insect-borne diseases is the most serious impact of climate change." To what extent do you agree? Discuss, with reference to examples. [8]

General thrust of the question

- The key idea behind the question is for candidates to compare the relative seriousness of the various impacts of climate change.
- Candidates should be able to describe the different impacts of climate change.
- They should also be able to support their answers with clear and specific named examples.
- For their conclusions, candidates should be able to weigh the relative seriousness of each impact and arrive at a reasoned conclusion as to which is the most serious.
- Candidates should be able to describe and explain the impacts of climate change, including the impact of mosquito borne diseases.
- They should be able to explain the impacts of climate change, either on humans or the environment.

- For their conclusions, candidates need to be able to assess each impact of climate change and come up with a conclusion as to which is the most serious.

Level descriptors

Level 1 (1 – 3 marks)

- Vague description of the role of one or more responses only.
- No specific named examples or only vague examples provided.
- No attempt made to compare the relative seriousness of each impact.
- Answer is vague and is not well developed.

Level 2 (4 – 6 marks)

- Clear description of one or more impacts.
- Clear and specific named examples for each impact cited.
- Some attempt may have been made to draw a conclusion of any one of the impacts being more serious.

Level 3 (7 – 8 marks)

- Clear description of least two impacts.
- Clear and specific named examples for each impact cited.
- A well-reasoned conclusion is drawn that argues why one specific impact is more serious than the others.
- Overall, the answer must be clearly explained, backed up by sound knowledge, with both sides of the argument considered and well-supported with examples.

3(a)(i) Describe the relationship between average daily food consumption per capita and the GDP per capita of the countries shown in Table 1. [3]

- In general, the higher that the GDP per capita, the higher the food consumption.
- However, there are a few exceptions. For example, the country highest GDP per capita, Luxembourg, has a slightly lower food consumption than Austria.
- Also, the country with the lowest GDP per capita, Burundi, does not have the lowest food consumption, but actually consumes more food than Eritrea, where the GDP per capita is higher.

3(a)(ii) Using examples from Table 1, explain why the average daily food consumption per capita varies greatly from country to country. [4]

- Food consumption varies due to variations in disposable income, which is the money that is available to use once taxes have been paid. People in countries like Luxembourg or United States with more disposable income can afford to buy more food.
- The prices of food also affects how much food people can afford to buy. In countries like the Japan, where food prices are high, people may buy less food.
- Food preferences also affect the amount of food and calories they eat. For example, in countries like the United States, people eat fast food or foods with a high fat content and may contain consume calories than if they ate other types of food.
- Population growth and overpopulation in countries like India may lead to food shortages and a lower average calorie intake for the people of a country.

- The stability of the food supply may affect the amount of food that is available for people to eat. For example, war or conflicts in countries like Afghanistan may disrupt the food supply and lead to lower calorie intakes.
- Natural disasters such as earthquakes in Japan may also disrupt the food supply and lead to food shortages and lower calorie intakes.
- Food safety can also affect calorie intake. Unsafe food cannot be eaten and, if alternatives are not available, food shortages may result.

3(b) Use Fig. 6 to help you explain the impacts of inadequate food consumption. [5]

Health impacts

- Inadequate food consumption can lead to malnutrition, which is a health condition where the body does not get sufficient or a balanced amount of nutrients. This leads to health problems like loss of weight or poor functioning of the organs.
- In extreme cases, starvation can result, where the lack of nutrients leads to extreme weight loss and a skeletal appearance, organ failure and eventually, death.

Economic impacts

- People who do not get enough food may suffer from lower productivity as they are unable to carry out their work properly due to ill health or lack of energy.
- Financial resources may also have to be diverted to health care to deal with the health problems caused by food shortages, leading to further financial hardship.
- Countries and individuals who suffer from food shortages may have to receive loans to buy food. If they are unable to repay the money, they may find themselves in long-term debt.

Political impact

- Social unrest may result if people who are facing food shortages take to the streets in protest and riot against the government, as is the case in countries like Venezuela.

Social impact

- People who are hungry and desperate may resort to scavenging for food in places like rubbish dumps, leading to health problems if they consume tainted food.

3(c) Explain how poverty can encourage the spread of diseases. [5]

- Poverty can lead to the spread of diseases as people cannot afford to buy food from themselves and therefore suffer from malnutrition or vitamin deficiency, which leads to diseases like scurvy or organ damage from lack of food.
- People who are poor also live in overcrowded slums, which encourages the spread of diseases.
- Poor people living in slums also must put up with the poor sanitation and sewage found in these areas this can lead to the spread of diseases like cholera.
- People living in poverty may not be able to afford a good education and therefore not have the knowledge to prevent the spread of diseases for themselves or for their children.
- Poor people will also not be able to afford the cost of medical treatment or medicines, which means that they will fall ill more frequently, allowing diseases to spread more easily.

- Candidates should be able to describe and explain the various ways of increasing food supply and overcoming food shortages.
- They should be able to explain how each way overcomes food shortages, either by increasing food supply, stockpiling or by reducing wastage.
- They should be able to show that all these measures play a part in reducing food shortages.
- For their conclusions, candidates need to be able to access each way of overcoming food shortages and come up with a conclusion as to which has the most impact.

Level descriptors

Level 1 (1 – 3 marks)

- Vague description of one or more strategies only.
- No specific named examples or only vague examples provided.
- No attempt made to compare the relative benefits of each impact.
- Answer is vague and is not well developed.

Level 2 (4 – 6 marks)

- Clear description of one or more strategies with its benefits explained clearly.
- Clear and specific named examples for each strategy cited.
- Some attempt may have been made to draw a conclusion as to why any one of the strategies is more beneficial.

Level 3 (7 – 8 marks)

- Clear description of least two strategies with its benefits explained clearly.
- Clear and specific named examples for each strategy cited.
- A well-reasoned conclusion is drawn that argues why one of the strategies is more beneficial than another.
- Overall, the answer must be clearly explained, backed up by sound knowledge, with the impacts and consequences well-supported with examples.

<p>4(a) Study Fig. 7 (Insert) is a map showing the world distribution of malaria in 2014. Describe and account for the distribution of countries with malaria in 2014. [6]</p>

Describe the distribution (2 – 3 marks)

- Countries with malaria are all located relatively near to the equator.

- Countries with the highest rates of malaria are found in less-developed countries (LDCs) in sub-Saharan Africa / southern and western Africa.
- Some countries in South America, South Asia and South-East Asia also have moderate rates of malaria.
- Europe and other regions to the far north and south of the equator have no ongoing malaria transmission.

Account for the distribution (3 – 4 marks)

Social factor

- A lack of proper sanitation in LDCs leads to the formation of pools of stagnant water that allows malaria-carrying mosquitoes to spread.

Economic factor

- LDCs also have poor provision of health care and people do not receive adequate medical care to treat malaria, allowing it to spread more rapidly.

Environmental factors

- Countries that are located near the equator have a warm and humid climate that is suitable for the breeding of the mosquitoes that spread the malaria parasite.
- Overcrowded living conditions in LDCs makes for perfect conditions for malaria-carrying mosquitoes to breed and find suitable hosts for the parasite to spread.
- Poor drainage and the presence of stagnant water in many cities in LDCs makes it easy for mosquitoes to breed and spread.

<p>4(b) Describe and account for the relationship between health care spending per capita and life expectancy. [6]</p>

Describe the relationship (2 marks)

- In general, with countries that spend more on health care with have people with a higher life expectancy.
- However, over \$2000 per capita the life expectancy begins to increase at a slower rate with increasing spending on health care.

Account for the relationship (4 marks)

- Health care spending can be in the form of training for health care professionals such as doctors and nurses. If a country spends more on training, there will be more health care professionals / a better doctor-patient ratio, which leads to better health care health and a longer life expectancy.
- Money can also be spent on building hospitals and other health care facilities. With more hospitals, the bed-patient ratio would improve and people would find it easier to seek medical care and assistance, thereby improving their health and increasing their life expectancy.
- Pharmaceuticals companies can also invest in health care research to find new drugs and therapies that can be used to treat diseases more effectively. This would improve patient's health and life expectancy.
- Governments can also improve health care and life expectancy by subsidising health care and reducing its cost for poorer patients, thus making it more affordable to them.
- Individually, people who spend more on health care services such as regular health screenings will be healthier and have a longer life expectancy.

4(c) How does HIV/AIDS impact individuals, communities and countries? [5]

Social impacts

- HIV/AIDS has many negative impacts. Firstly, it will decrease life expectancy and increase the infant mortality rate, as people who suffer from AIDS will face premature deaths.
- Secondly, it has led to an orphan crisis as children whose parents have died from AIDS are left to fend for themselves and are not able to afford food or education.
- Thirdly, there is a very negative social stigma associated with HIV/AIDS and people with the disease may find themselves shunned and unable to find jobs or housing.

Economic impacts

- Next, AIDS has a very high impact on health care costs, both for the individual and the country. The cost of treatment building hospitals and training medical professionals to treat AIDS patients, as well as the high cost of drugs, can be a huge financial burden.
- AIDS patients are unable to work and the deaths of large number of people from AIDS will affect the economic development of a country as it may then be short of skilled labour.

4(d) "The individual plays the most important role in controlling the spread of HIV/AIDS." To what extent do you agree? Explain your answer with references examples. [8]

General thrust of the question

- The key idea behind the question is for candidates to describe the various measures to control the spread of HIV/AIDS and compare their effectiveness.
- Candidates should be able to describe and explain the different strategies to control the spread of HIV/AIDS and show how each has both benefits and limitations in helping to curb the spread of the virus.
- They should also be able to support their answers with clear and specific named examples.
- For their conclusions, candidates should be able to weigh the relative benefits and limitations of each measure and reach a conclusion as to which has the greatest effect in controlling the spread of AIDS.
- Candidates should be able to describe and explain how various groups can help to control the spread of HIV/AIDS.
- They should be able to explain how the actions taken by each group can fight the spread of HIV/AIDS.
- For their conclusions, candidates need to be able to compare the effectiveness of each group in controlling the spread of HIV/AIDS and come up with a conclusion why one group might be more effective than another.
- For maximum marks, candidates should be able to show that while some groups may have a greater impact on controlling the spread of HIV/AIDS, the most effective way of controlling it is for the various groups to work together and complement each other in the fight against HIV/AIDS.

Level descriptors

Level1 (1 – 3 marks)

- Vague description of steps taken by stakeholders to control the spread of HIV/AIDS.

Class	Name	Index No
-------	------	----------



ST.HILDA'S SECONDARY SCHOOL

2, TAMPINES STREET 82, SINGAPORE 528986, TEL: 63055277 FAX: 67865011

ST. HILDA'S SECONDARY SCHOOL ST. HILDA'S SECONDARY SCHOOL ST. HILDA'S SECONDARY SCHOOL.
 ST. HILDA'S SECONDARY SCHOOL ST. HILDA'S SECONDARY SCHOOL ST. HILDA'S SECONDARY SCHOOL.
 ST. HILDA'S SECONDARY SCHOOL ST. HILDA'S SECONDARY SCHOOL ST. HILDA'S SECONDARY SCHOOL.
 ST. HILDA'S SECONDARY SCHOOL ST. HILDA'S SECONDARY SCHOOL ST. HILDA'S SECONDARY SCHOOL.
 ST. HILDA'S SECONDARY SCHOOL ST. HILDA'S SECONDARY SCHOOL ST. HILDA'S SECONDARY SCHOOL.

PRELIMINARY EXAMINATION 2017

PURE GEOGRAPHY

2236/01

Paper 1

Level: Secondary 4 Express

Duration: 1 hour 40 minutes
Date: 23 August 2017

Additional material: 1 Insert

READ THESE INSTRUCTIONS FIRST

Write your name and index number on all the work you hand in.

Write in dark blue or black pen.

You may use a soft pencil for any diagrams or rough working.

Do not use staples, paper clips, highlighters, glue or correction fluid.

Section A

Answer Question 1.

Section B

Answer one question.

Write all answers in the foolscap papers provided.

Candidates are encouraged to support their answers with the use of relevant examples.

Sketch maps and diagrams should be drawn whenever they serve to illustrate an answer.

At the end of the examination, fasten all your work securely together.

The number of marks is given in brackets [] at the end of each question or part question.

Set by: Mrs Mei Quek

Checked by: Mrs Jessie Leong, Mdm Chee Siew Yan

This Question Paper consists of 8 printed pages, including this cover page

ST HILDA'S PRELIMINARY EXAM 2017
Sec 4Exp Pure Geography

[Turn over

Section A

This question is **compulsory**.

- 1 A group of students were studying beach profiles. They went to their local beach at Havana, the capital city of Cuba. Cuba is an island in the Caribbean, which is attractive to tourists.
- (a) Briefly describe how the gradient of a slope can be obtained using a clinometer. [4]
- (b) The students had forgotten to pack a clinometer for their investigation. Hence they improvised another method to obtain the beach profile as shown in Fig. 1 below.

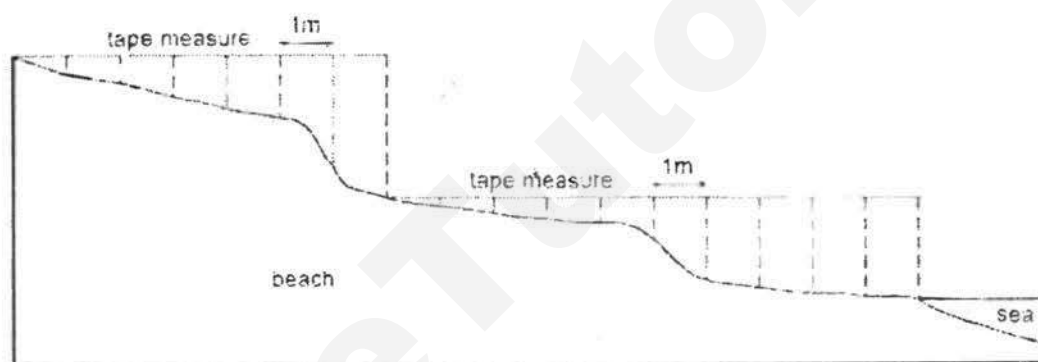
**Method:**

1. Stretch the tape measure across the beach from the cliff to the shoreline.
2. Measure the difference in height between the tape measure and the surface of the beach in metres.
3. Repeat this measurement every metre across the beach.

Fig. 1

- (i) Suggest the advantages and disadvantages of this method. [3]
- (ii) What might affect the accuracy or reliability of their data collection? [2]

- (c) The results of the students' measurement are shown in Table 1 below.

Distance from cliffs (m)	0	1	2	3	4	5	6	7	8	9	10	11	12	13	14	15
Difference in height between tape measure and beach (m)	0.0	0.2	0.4	0.5	0.5	0.6	0.6	1.0	1.1	1.2	1.2	1.6	1.7	1.8	1.8	1.9

Table 1

- (i) Use the results to plot the beach profile (Fig. 2) in the Insert. [3]
- (ii) State a suitable hypothesis that the students can further investigate about the beach profile. What additional data would the students need to collect for the investigation? [2]
- (d) Another group of students were investigating the impact of tourism in Havana City. They focused on 3 tourist areas, Area 1, Area 2 and Area 3 along the coast. Fig. 3 below shows the results of their investigation.

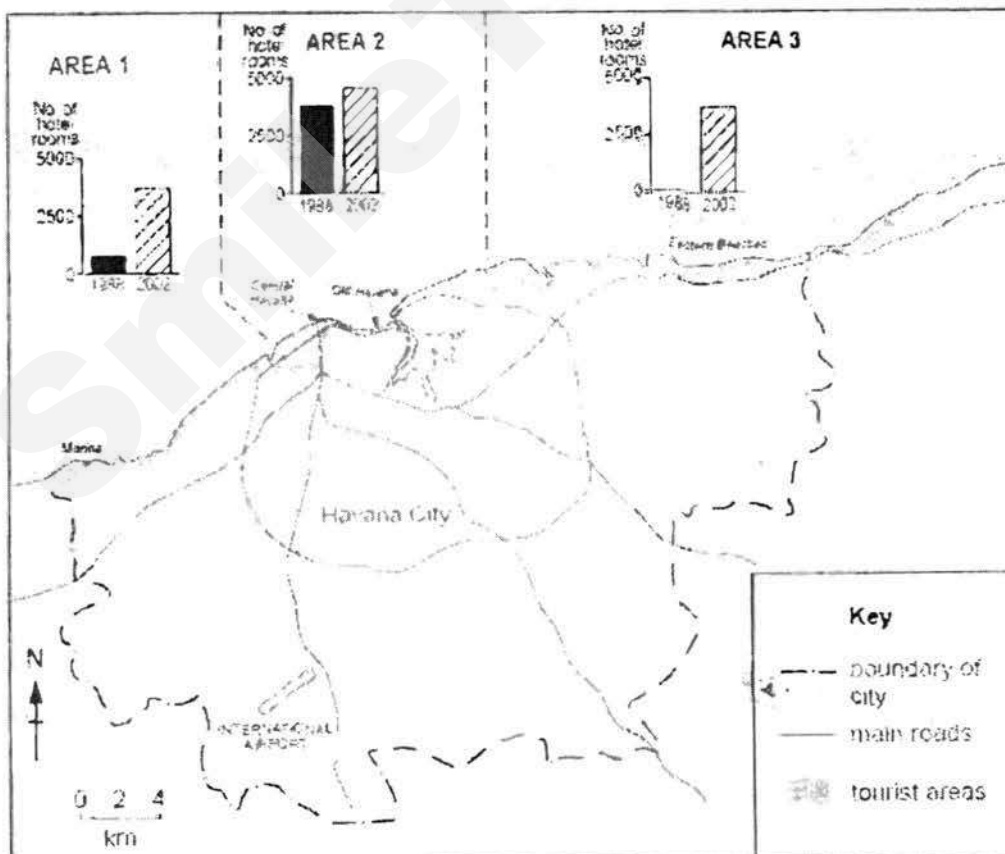

Fig. 3

Page 4 of 8

- (i) Suggest how the students might have obtained the data on number of hotel rooms. [1]
- (ii) How far would the results in Fig. 3 support the hypothesis that *'Tourism has led to the development of infrastructure and facilities in Havana City'*? [5]
- (e) The same group of students discussed that for their next investigation, they would like to find out whether the rise in tourist numbers is due to the provision of goods and services in the various areas. What data collection methods could they use? Describe how they may carry out this new investigation. [5]

Section B
Answer one question.

- 2 (a) Study Fig. 4 below which shows a section of a coastal area.



Fig. 4

- (i) Describe the appearance and characteristics of the coast shown in Fig. 4. [3]
- (ii) Explain the coastal processes that led to the shape of the coastline and the formation of the coastal features. [6]
- (b) With the help of labelled diagrams, explain how groynes help to protect a coast against sediment transport. [5]

- (c) Fig. 5 below shows an area of coastline before and after a storm.

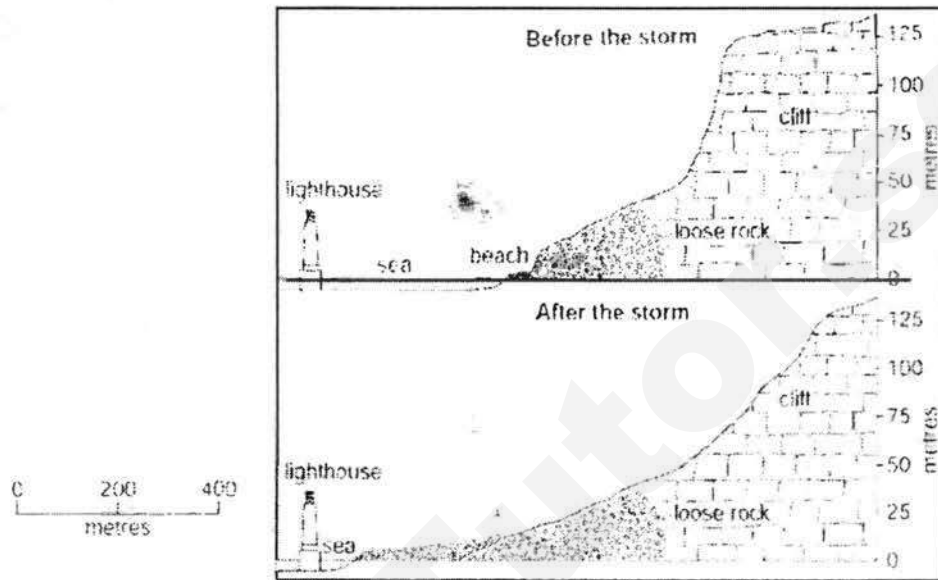

Fig. 5

Using evidence from Fig. 5 only, describe the effects of the storm.

[3]

- (d) *'The only aim of soft engineering strategies is to protect coasts from strong waves.'*

How far do you agree with this statement? Explain your answer with examples.

[8]

3 (a) Fig. 6a and 6b below show some human activities that take place at a coastal area.

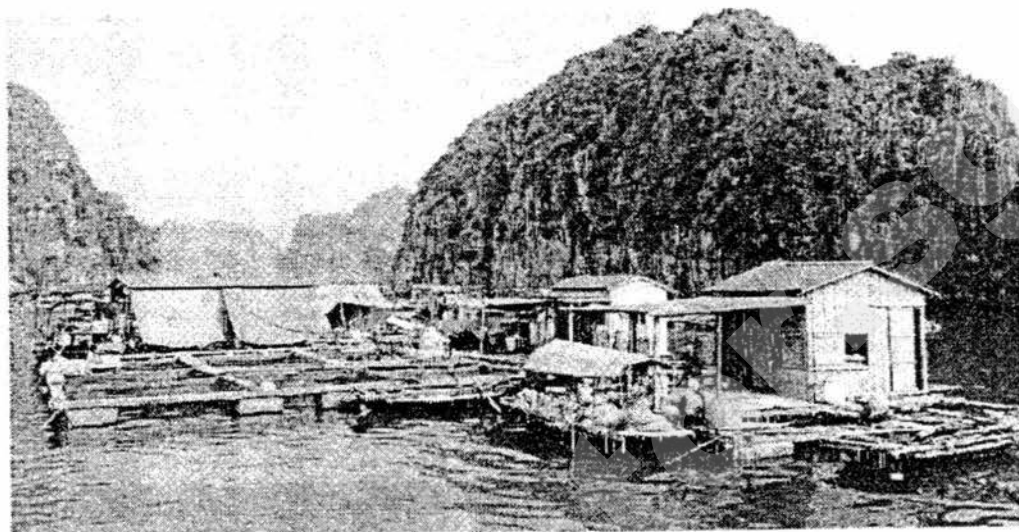

Fig. 6a



Fig. 6b

- (i) With the help of Fig. 6a and 6b, describe the value of coasts to human beings. [3]
- (ii) Explain how the human activities shown can endanger the coastal area. [6]

- (b) Study Fig. 7 below which shows information about international tourists to Kenya from different continents.

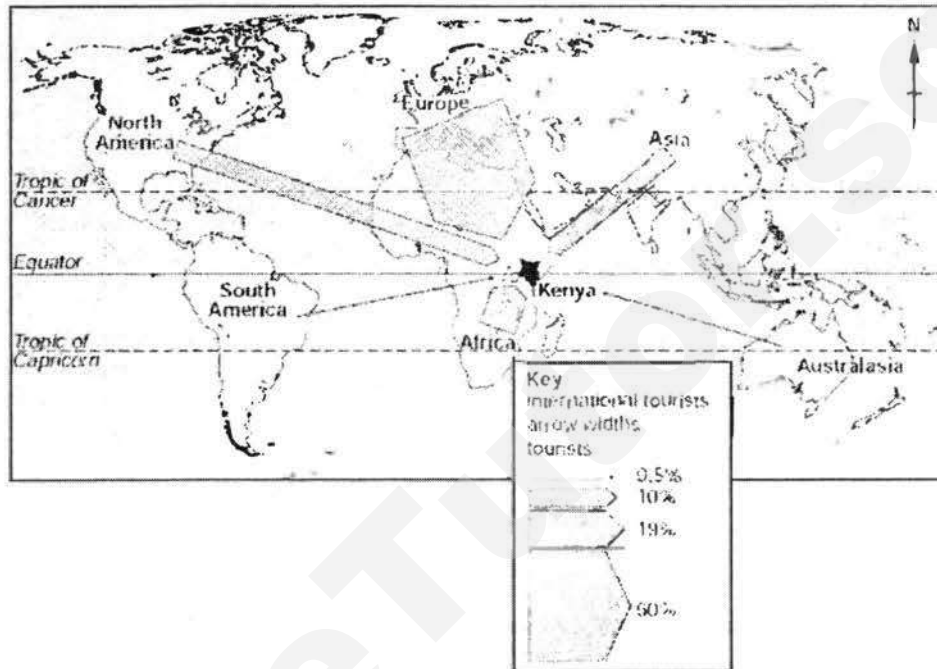

Fig. 7

- Compare the percentage of international tourists to Kenya from the different continents. [3]
- (c) Explain, with examples, how natural disasters can affect the tourism industry. [5]
- (d) 'Destination factors, rather than demand factors, influence the decisions of tourists.'
How far do you agree with this statement? Explain your answer with examples. [8]

~ End of Paper ~

Credits

Fig. 1, 2, 3, 5, 7 CIE

Fig. 4 <http://www.metronews.ca/content/dam/thestar/uploads/2017/3/8/azurewindow.jpg>

Fig. 6a <https://upload.wikimedia.org/wikipedia/commons/thumb/...>

Fig. 6b http://www.zicasso.com/sites/default/files/styles/original_scaled_down/public/photos/...

Cross-section of beach



Class	Name	Index No
-------	------	----------



ST.HILDA'S SECONDARY SCHOOL

2, TAMPINES STREET 82, SINGAPORE 528986, TEL: 63055277 FAX: 67865011

ST. HILDA'S SECONDARY SCHOOL ST. HILDA'S SECONDARY SCHOOL ST. HILDA'S SECONDARY SCHOOL.
 ST. HILDA'S SECONDARY SCHOOL ST. HILDA'S SECONDARY SCHOOL ST. HILDA'S SECONDARY SCHOOL.
 ST. HILDA'S SECONDARY SCHOOL ST. HILDA'S SECONDARY SCHOOL ST. HILDA'S SECONDARY SCHOOL.
 ST. HILDA'S SECONDARY SCHOOL ST. HILDA'S SECONDARY SCHOOL ST. HILDA'S SECONDARY SCHOOL.
 ST. HILDA'S SECONDARY SCHOOL ST. HILDA'S SECONDARY SCHOOL ST. HILDA'S SECONDARY SCHOOL.

PRELIMINARY EXAMINATION 2017

PURE GEOGRAPHY

2236/02

Paper 2

Level: Secondary 4 Express

Duration: 1 hour 30 minutes

Date: 7 August 2017

Additional Material: 1 Insert

READ THESE INSTRUCTIONS FIRST

Write your name and index number on all the work you hand in.

Write in dark blue or black pen.

You may use a soft pencil for any diagrams or rough working.

Do not use staples, paper clips, highlighters, glue or correction fluid.

Section A

Answer one question.

Section B

Answer one question.

Write all answers in the foolscap papers provided.

Candidates are encouraged to support their answers with the use of relevant examples.

Sketch maps and diagrams should be drawn whenever they serve to illustrate an answer.

At the end of the examination, fasten all your work securely together.

The number of marks is given in brackets [] at the end of each question or part question.

This Question Paper consists of 7 printed pages, including this cover page

Section A
Answer one question.

- 1(a) Fig. 1 is a map showing the epicentre of the 2004 Asian Tsunami as well as the countries that were affected by it.

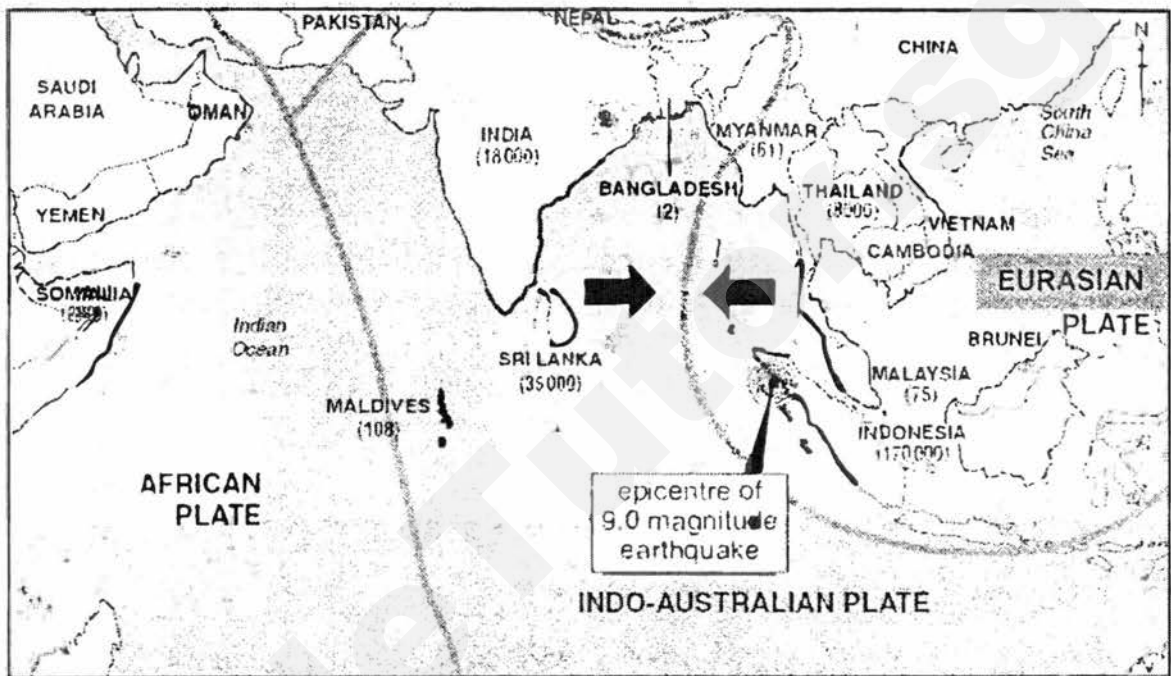

- Key**
- coastline severely hit by tsunamis
 - plate boundary
 - number of deaths
 - plate movement

Fig. 1

- (i) With reference to Fig. 1, explain how the earthquake was triggered. [5]
- (ii) With reference to Fig. 1, describe how distance from epicentre is related to the number of deaths in the countries affected by the tsunami. [4]
- (b) Explain how some countries have been able to reduce earthquake damage through the use of earthquake monitoring and warning systems. [4]

- (c) Fig. 2 below shows a cyclone-resistant housing prototype.

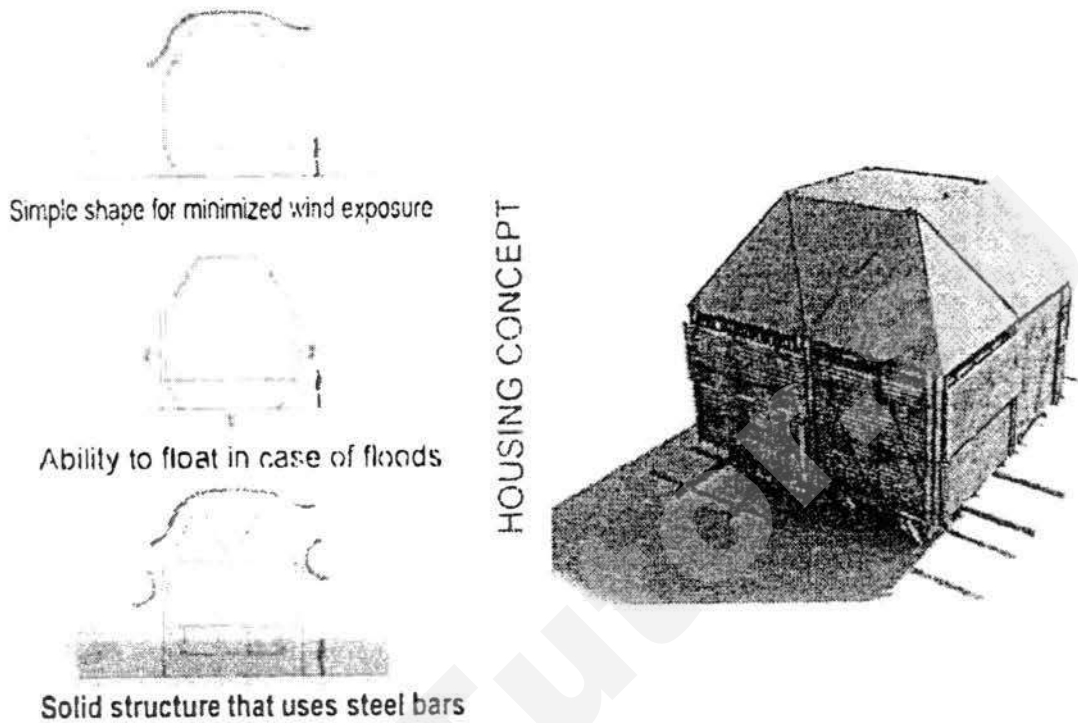

Fig. 2

Suggest how the features of the housing in Fig. 2 can reduce the impacts of tropical cyclones.

- (d) "All volcanoes are similar in formation, physical characteristics and nature of eruption."
How far do you agree with this statement? Explain your answer with relevant examples.

2(a) Fig. 3 below shows a climograph of a location in Monsoon Asia.

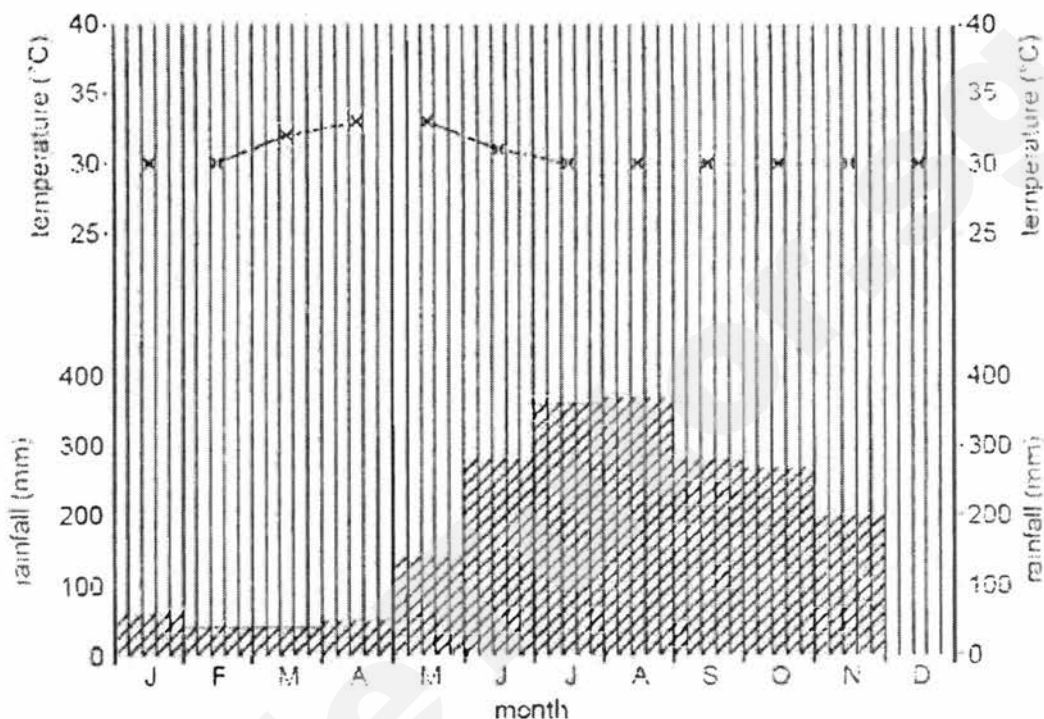

Fig. 3

- (i) Describe and account for the temperature shown in Fig. 3. [3]
- (i) Describe and account for the distribution of the rainfall throughout the year shown in Fig. 3. [6]
- (b) Study Fig. 4 (Insert). Using the information from Fig. 4, account for the formation and movement of the tropical storms. [3]
- (c) With the help of labelled diagrams, describe and explain the formation of relief rain. [5]
- (d) "Global climate change is due to human demand for resources."
How far do you agree with this statement? Explain your answer with relevant examples. [8]

Section B
Answer one question.

3(a) Study Fig. 5 which shows the location of meat processing factories in New Zealand.

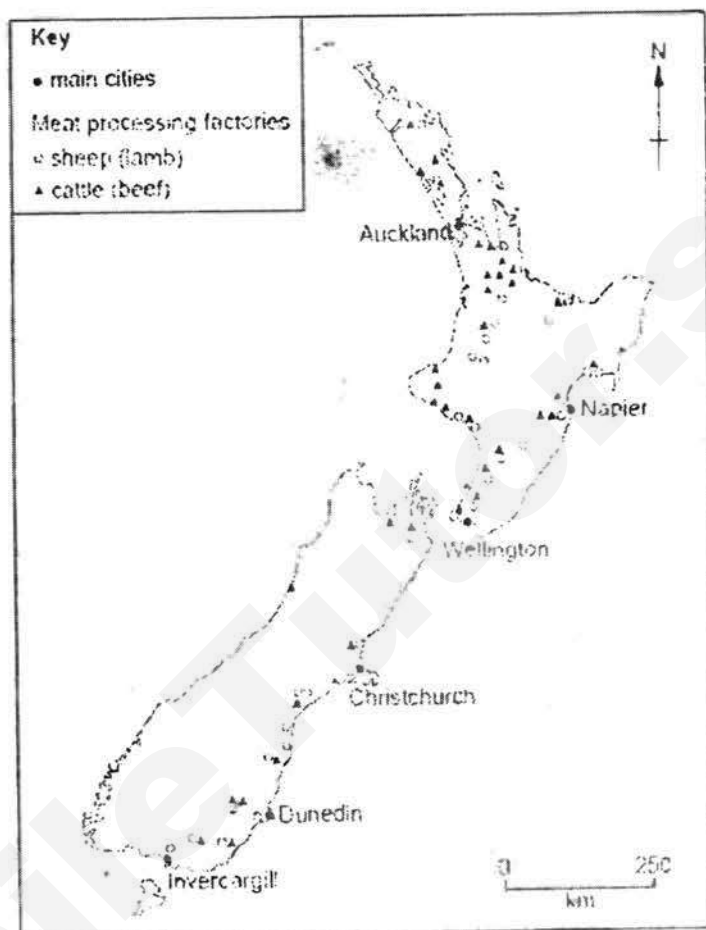

Fig. 5

- (i) Food processing is part of an agribusiness chain. Describe the characteristics of an agribusiness. [3]
- (ii) With reference to Fig. 5, describe the distribution of meat processing factories in New Zealand. [4]

- (b) Fig. 6 shows the estimated costs of obesity in United States of America in 2030.

BULGING OBESITY COSTS IN USA IN 2030



Fig. 6

- Using information from Fig. 6 only, describe and explain the impacts of excessive food consumption on a country. [5]
- (c) Explain the physical factors that affect the production of food. [5]
- (d) "Rapid population growth is the most important cause of food shortage in a less developed country."
How far do you agree with this statement? Explain your answer. [8]

4(a) Study Fig. 7a (Insert) and 7b below.

In 2009, three countries were certified malaria-free in the past four years but that is out of 108 where the disease is endemic. Vast numbers of bed nets treated with insecticide have been provided by donors and distributed in malaria-endemic regions. Every small child and pregnant woman should sleep under one to keep away the mosquitoes in the night. New drugs – compounds involving artemisinin – have been developed and widely distributed to replace older antimalarials.

Fig. 7b

- (i) Using information from Fig. 7a (insert) only, describe how the extent of malaria (distribution, number of cases and deaths) has changed over the years. [6]
- (ii) Using information from both Fig. 7a (insert) and 7b, describe and suggest reasons for the number of malaria cases reported in Africa in 2009. [3]
- (b) Study Fig. 8 (Insert), which shows the three common traits of corn that are grown using biotechnology in United States of America. Bt corn is resistant to pest, while HT corn is resistant to herbicide.
- Describe the changes in the percentage of areas where the different types of genetically engineered corn was grown.
- (c) Explain how multiple cropping and crop rotation can increase a farm's productivity.
- (d) *"Environmental factors are responsible for the spread of all diseases in the less developed countries."*
- How far do you agree with this statement? Explain your answer.

~ End of Paper ~

Credits

Fig. 2 <https://www.treehugger.com/green-architecture/affordable-disaster-resistant-bamboo-housing-floats-in-flood-hot-architects.html>

Fig. 3, 4, 5 CIE

Fig. 6 <https://www.bariatricsurgeryworld.com/wp-content/uploads/2014/04/bulging-obesity-statistics-1.jpg>

Fig. 7a and 7b https://static.guim.co.uk/sys-images/Guardian/Pix/maps_and_graphs/2011/10/18/Malaria_web.gif

Fig. 8 <https://userscontent2.emaze.com/images/b6863f35-486b-4a4b-b06b-992b7e26c848/5cac4c2c7bac99ac77deda2f730e9728.png>

Fig. 7a for Question 4

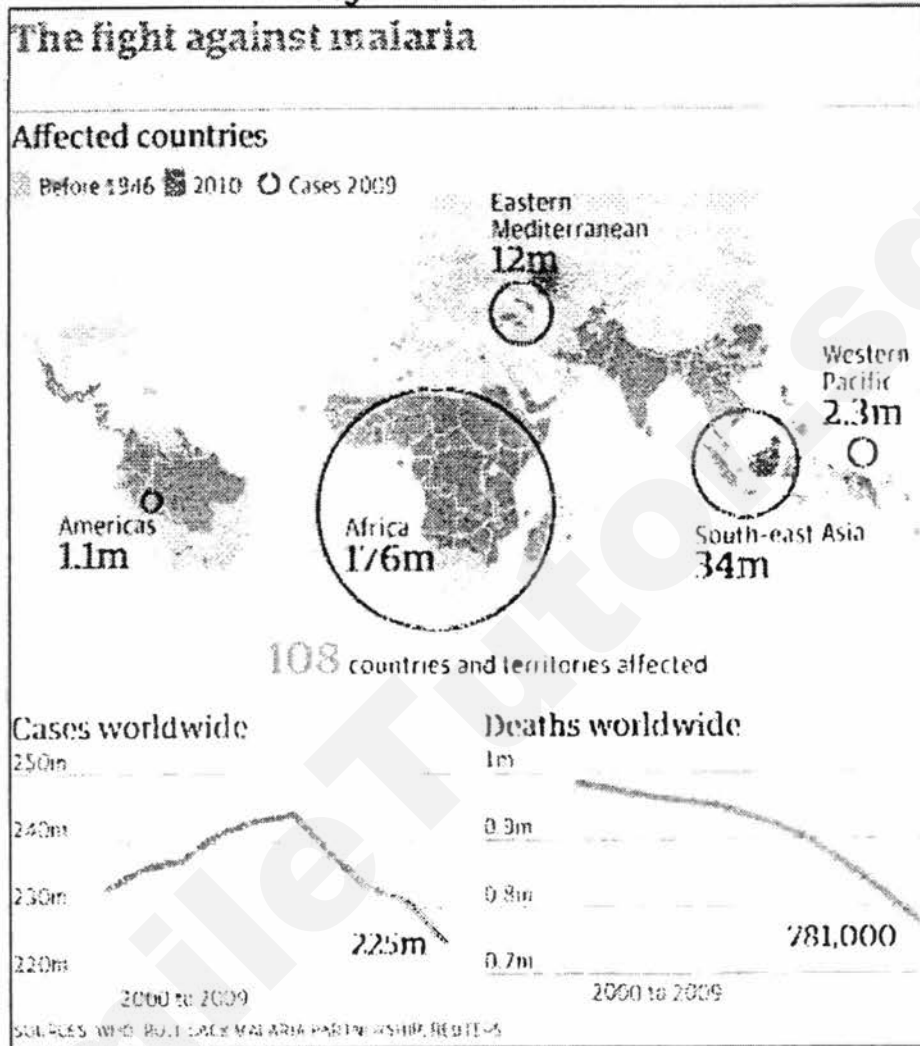
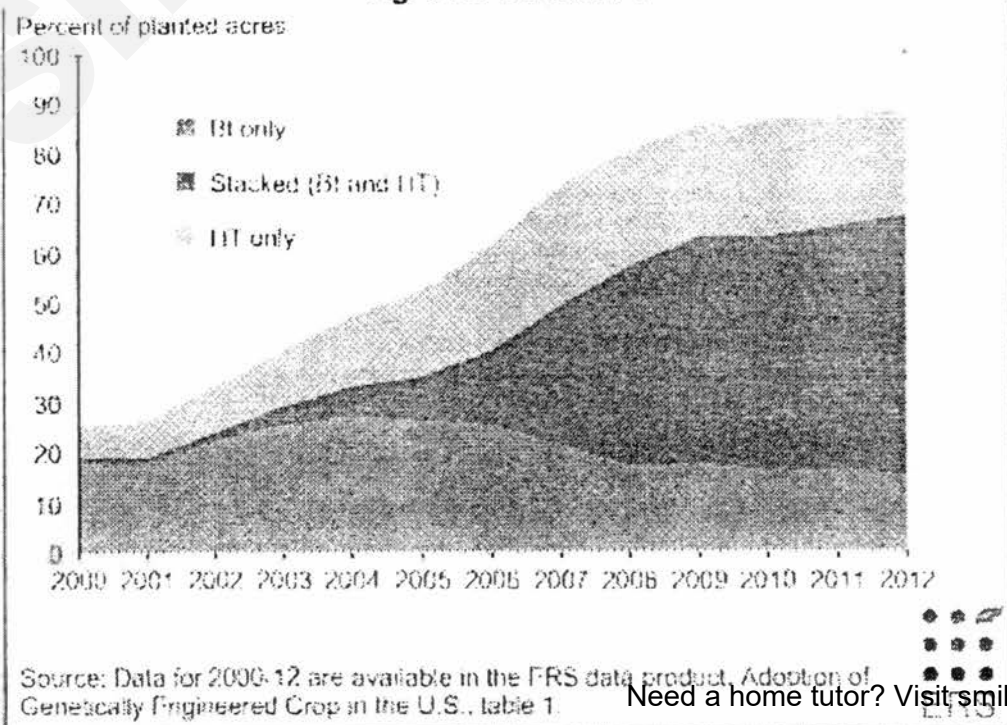

Fig. 8 for Question 4



St. Hilda's Sec School
 Sec 4 Exp Pure Geography
 Answers to Preliminary Exam 2017 Paper 1

1(a)

- Place ranging poles along transect line
- Ensure they are vertical, not sunk into sand
- Same length of pole above surface at each point
- Use a clinometer to measure / read angle of elevation
- Hold clinometer next to top / at agreed height on ranging pole / eye level
- Sight other ranging pole at top / agreed height on ranging pole / eye level

(b)

(i) Advantage

- Easy to do / no need to measure angle
- Needs little equipment / only needs tape measure / ruler

Disadvantage

- Tape might not be long enough
- Difficult to ensure tape measure is straight
- Complication of having to add height difference to readings/ measurements.

(ii)

- Reading / parallax error of the difference in height - inaccurate
- Measurements taken every metre may miss change in slope - unreliable

(c)

(i) 3 marks for correct plotting of all points; 2 points for 1-4 errors, 1 mark for 5-8 errors

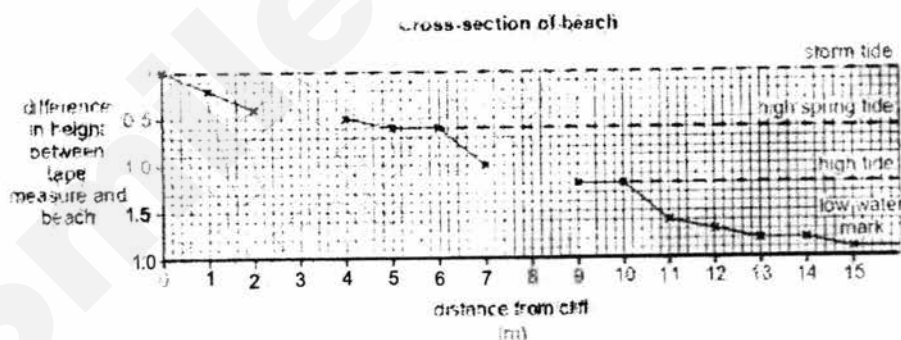

(ii) Any possible answer

E.g.: The beach profile is influenced by the size of materials; Data: sediment size

(d)

(i) Secondary data / internet research / annual reports from hospitality industry / government

(ii)

- Support to some extent only / only for facilities, not for infrastructure
- Facilities: increase in no. of hotel room in all 3 Areas
- I.e.: Area A from 625 (1998) to 3750 (2002) – any data
- Infrastructure: not able to see how no. of main roads / international airport have developed
- However, able to see that there are main roads leading directly to Area 2 (Central Havana) from airport

(e)

- Landuse survey

- Find out the no. of shops, buildings that provide goods and services to the tourists in the tourist areas
- Analyse the results i.e.: areas with more amenities attract more tourists
- Interview tourists / use survey forms or questionnaires
- Can include those working in tourism-related jobs / shopkeepers
- At least 30 respondents
- Use random / systematic sampling
- Ask both open and closed questions on the factors / causes

2(a)

- (i)
- Rocky coast / made up of rock
 - Presence of notches, caves, arch
 - Uneven coastline / headlands+bay
- (ii)
- ~~Alternate bands of more resistant / hard rocks and less resistant / soft rocks are arranged at right angles to the coast.~~
 - The less resistant / soft rocks get eroded faster and curve inwards as bays.
 - The remaining more resistant / hard rocks extending into the sea are called headlands.
 - Some parts of headland may have less resistant rocks that erode more quickly.
 - ~~Base of headland gets undercut to form cave.~~
 - Caves develop at either side of headland and erosion joins the two caves together to form arch.

(b)

1 mark for diagram(s)

- Groyne are low walls, built at right angles to the shore
- Tips may be further angled about 5 to 10 degrees
- To prevent materials from being transported along the coast by longshore drift.
- Cause deposition on the side facing longshore drift (updrift side), thus extending and enlarging beach on the downdrift side

(c)

- Collapse of cliff
- Almost vertical rock face becomes less steep rock face
- Extent of loose rocks increased from 400m to 760m / extended seawards

(d)

Relevant points: Need to explain 2 strategies and bring in at least 1 other aim for each strategy, e.g.: extending the beach (growing of mangroves), beautifying the beach (beach nourishment), stabilizing sand dunes etc

Strategy (E.g.)	Description (WHERE?)	Successes	Limitations
Encouraging coral reef growth (Thuru, Maldives) What's coral reef ecosystem? <ul style="list-style-type: none"> • Masses of corals growing in tropical shallow seas Distribution <ul style="list-style-type: none"> • Between the tropics 	<ul style="list-style-type: none"> • Conserve coral reefs and restore damaged ones • Create artificial reefs by placing steel / concrete on sea floor • WHERE? - Along coast 	<ul style="list-style-type: none"> • Coral reefs weaken wave energy by reducing speed of waves approaching coast • Enhance fishing opportunities • Healthy coral reefs can help protect coasts • E.g.: In 2004 Indian Ocean Tsunami, coral reefs provided buffers 	<ul style="list-style-type: none"> • Need years to establish coral reef ecosystem • Not all coastal regions can support coral reefs (limited to only tropical shallow seas) • Can be severely damaged by severe storms • Require constant effort to reduce water

<p>E.g.: SEA</p> <p>Environmental conditions (Fig 1.56)</p> <p>Pressures (Fig 1.59)</p> <ul style="list-style-type: none"> • Overcollection • Fishing methods • Recreational use of coast • Coastal development • Climate change 		<p>to weaken wave energy</p> <p>Other value of coral reefs</p> <ul style="list-style-type: none"> • Provide habitat for marine creatures • Tourist attractions 	<p>pollution (as discharging of sewage and other waste into the sea pollutes the sea and can threaten the growth of coral reefs)</p> <ul style="list-style-type: none"> • To succeed in a long run, need cooperation from public, fishermen, industries, government
<p>Planting mangroves (Parts of Aceh)</p> <p>What's mangrove ecosystem?</p> <ul style="list-style-type: none"> • Tropical / sub-tropical plants that are halophytes (salt-tolerant) <p>Distribution</p> <p>Between the tropics, along low lying, sheltered coasts with muddy and waterlogged land</p> <p>E.g.: Southeast Asia, Australia, W Africa, tropical areas of the Americas</p> <p>Adaptation</p> <ul style="list-style-type: none"> • Leaves – special salt glands to secrete excess salt • Fruits floating fruits; tube-like fruits • Roots pencil roots; prop roots; kneed roots <p>Pressures (Fig 1.69)</p> <ul style="list-style-type: none"> • Demand for fuel wood and charcoal • Conversion to other land uses • Coastal development • Rising sea level 	<ul style="list-style-type: none"> • WHERE? - Along coasts 	<ul style="list-style-type: none"> • Roots can absorb energy of incoming waves • Roots help to trap sediments, bind loose soil and reduce coastal erosion • Extensive areas of mangroves can reduce the loss of life and damage caused by tsunamis. • E.g.: In 2004, Indian Ocean Tsunami, mangroves planted by one of the villages in Tamil Nadu, India slowed down the waves. Much of the hand around the village was flooded, but the village itself suffered minimal damage • Extends and enlarges beach seawards as mangroves grow seawards <p>Other value of mangroves</p> <ul style="list-style-type: none"> • Provide breeding ground and habitat for marine creatures • Provide wood and non-wood forest products • Improve water quality – natural filters 	<ul style="list-style-type: none"> • Need years to establish mangrove ecosystem • Not all coastal regions can support mangroves (limited to only tropical / sub-tropical sheltered areas) • Depth of coast may become shallower affecting coastal transportation and port activities • Narrow mangrove strips provide limited coastal protection against tsunamis • When uprooted or snapped off at mid-trunk and swept inland, can cause extensive property and life damage • Young mangroves are fragile, thus mangrove planting require cooperation of locals who need to prevent their farm animals from grazing on mangrove plantations
<p>Beach nourishment (Siloso Beach, Singapore)</p>	<ul style="list-style-type: none"> • Constant replenishment of sand to a beach that is being eroded e.g.: by longshore drift • WHERE? 	<ul style="list-style-type: none"> • Extends and enlarges beach seawards → (lead to) • Improves beach quality and protects against storms 	<ul style="list-style-type: none"> • Short term protection (10 years) • Sand needs to be constantly replenished • Impractical for places with scarce supply

	- Along beach		<ul style="list-style-type: none"> • Serious consequence on wildlife e.g.: coral reefs and coastal environment may be covered by sand • Costs very high
<p>Stabilising coastal dunes (Triton Place, W Australia)</p> <p>What's a coastal / sand dune?</p> <ul style="list-style-type: none"> • Loose sand piled up on a coast by wind • Conditions that help the formation of a dune = ✓ coast with abundant dry sand ✓ coast that experience prevailing onshore winds ✓ availability of space for sand to be piled up ✓ presence of vegetation (e.g.: spinifex and marram grass) to 'trap' sand <p>Why does it need to be stabilised?</p> <ul style="list-style-type: none"> • A dune can be blown further inland by strong winds and can cause damages by burying houses and roads • So, need to stabilise them by planting grasses to prevent them from migrating inland 	<ul style="list-style-type: none"> • Plant vegetation (e.g.: spinifex and marram grass) • Build fences, access paths to prevent dunes from being disturbed by human traffic 	<ul style="list-style-type: none"> • Roots of grasses can trap and bind sand together, preventing erosion • Matting used for planting can add nutrients when it rots • Stabilised dunes help defend coasts and human property like houses and roads against coastal erosion and flooding from waves • Dunes provide habitat for many animals. (e.g.: migrator, birds) 	<ul style="list-style-type: none"> • Vegetation cannot totally prevent coastal erosion • Moving vehicles and people walking across dunes can damage the vegetation and lead to destabilisation • Sufficient, convenient access must be provided so that there is no need for the use of shortcuts through the dunes • In a long run, human activities need to be minimised along coasts • Costs of fences and maintenance high

L1 (0-3)

- Answer will be generalized or with minimal support if any given at all.
- Reasoning may be rather weak and expression may be unclear.
- Basic answer that has little development, lack examples or other evidences / sketchy examples.

L2 (4-6)

- Disagreement / agreement will be supported by appropriate detail. Or, both disagreement & agreement considered but with patchy support.
- Good reasoning and logic in parts of answer with good expression in places.
- Not a full answer, some examples or other evidence presented in at least 1 place in answer.

L3 (7-8)

- Both disagreement & agreement are considered and well supported.
- Reasoning is clear and with good expression.
- Comprehensive answer, supported by sound knowledge. Examples or other evidence extensive.

3(a)

- (i)
- Fishing / aquaculture - livelihood
 - Settlement - for fishermen and their family
 - Recreation / tourism - fishermen may supplement their income by bringing tourists out to sea in their boats
- (ii)
- Overcollection of corals or other marine life - disrupts coral reef ecosystems
 - Fishing methods i.e.: dynamite blasting likewise destroys coral reef ecosystems
 - Aquaculture may lead to removal of mangrove ecosystems
 - Sewage or litter from settlement may pollute the coastal areas
 - Recreational use of coast can lead to water pollution like oil spills from boats
 - Coastal development for tourism i.e.: land reclamation can lead to loss of coastal ecosystems

(b)

- Largest group from Europe i.e.: 60%
- Smallest from S America & Australia i.e.: 0.5%
- 9% more tourists from Africa than N America & Asia

(c)

- Can discourage tourists from visiting destination & citizens of affected country from travelling
- E.g.: Iceland volcanic eruption, 2011; Japan tsunami, 2011 (any relevant e.g.)
- However, may encourage domestic tourism
- Or, encourage tourist industry to slash prices to lure tourists back to destination, hence may still be attractive to tourists who want a good deal

(d)

Relevant points: Need to compare demand factors with destination factors

Demand factors	Destination factors
Disposable income <ul style="list-style-type: none"> • The amount of money available for an individual to spend, or save, after taxes • Rapid economic growth (e.g.: in China, India) has increased disposable income, allowing people to travel 	Attractions <ul style="list-style-type: none"> • Features or qualities that make a place interesting or enjoyable • Can be natural or built E.g.: Dubai
Leisure time <ul style="list-style-type: none"> • A part of a day, week, year without work commitments aka relaxation time • Increase in leisure time due to shorter working weeks, more public holidays & more paid annual leave • With more income + paid leave, may be more inclined to travel 	Investments in infrastructure & services <ul style="list-style-type: none"> • Transport & communication networks, electrical frameworks, systems for water & waste disposal, accommodation • Particular type of help or work provided to customers E.g.: Changi Airport Terminal 4
Changing lifestyle <ul style="list-style-type: none"> • Travelling has become a form of relaxation • People live longer & are more physically fit to travel frequently i.e.: healthy retirees 	Access to information <ul style="list-style-type: none"> • Tourists are more likely to visit when travel-related info (transport routes, weather conditions) is easily obtained outside &

such as 'grey' nomads in Australia	within destination <ul style="list-style-type: none"> • Helps is info is available in different languages, local tour guides & travel agents are knowledgeable
<p>L1 (0-3)</p> <ul style="list-style-type: none"> • Answer will be generalized or with minimal support if any given at all. • Reasoning may be rather weak and expression may be unclear. • Basic answer that has little development, lack examples or other evidences / sketchy examples. <p>L2 (4-6)</p> <ul style="list-style-type: none"> • Disagreement / agreement will be supported by appropriate detail. Or, both disagreement & agreement considered but with patchy support. • Good reasoning and logic in parts of answer with good expression in places • Not a full answer, some examples or other evidence presented in at least 1 place in answer. <p>L3 (7-8)</p> <ul style="list-style-type: none"> • Both disagreement & agreement are considered and well supported. • Reasoning is clear and with good expression. • Comprehensive answer, supported by sound knowledge. Examples or other evidence extensive. 	

St. Hilda's Sec School
 Sec 4Exp Pure Geography
 Answers to Prelim Exam 2017 Paper 2

1(a)

(i)

- The oceanic Indo-Australian plate converges with the continental Eurasian plate
- As they do so, the Indo-Australian plate subducts under the Eurasian plate
- They exert friction on one another, causing pressure to build up at the boundaries.
- Pressure gradually builds up in the plates and energy is stored up in the Earth's crust.
- When the rocks can no longer contain the pressure, energy is released suddenly as an earthquake. This energy radiates out through the crust and onto the Earth's surface.

(ii)

- There is no relationship between distance from epicentre and number of deaths.
- Although Indonesia suffered the most deaths of 170,000 as it is a closest to the epicenter
- Countries that are further away such as Sri Lanka, had more deaths of 35,000 than relatively close countries such as Malaysia which had far fewer deaths of only 75
- Even countries equally distant from the epicentre like India (18000 deaths) & Bangladesh (2 deaths) differ greatly

[1m each. Students can quote any other relevant data]

(b)

- Involves **studying history** (when, where) of earthquakes—prediction of seismic risks.
- Hence **restrict development** in certain areas
- Involves **installing earthquake sensors** in earthquake-prone zones
- It helps **monitor the frequency of vibrations** and detect possible developments of an earthquake.
- For e.g., in Japan, earthquake motion data is gathered from hundreds of observation stations installed on **bridges and roads**.
- These stations **monitor ground motion** and enable the occurrence of an earthquake to be **predicted**.
- Earthquake sensors are also used to quickly estimate **damage** to bridges, railways or other infrastructure [any 4 pts, 1m each]

(c)

ACCEPT POSSIBLE ANSWERS

- 'Simple shape for minimized wind exposure', so housing will not be toppled so easily
- 'Ability to float in case of floods', so instead of being submerged by the flood water, housing will be intact
- 'Solid structure that uses steel bars' prevent walls and roofs from being blown off by the strong winds of cyclones / swept off by flood water
- Or being damaged by debris in the wind / flood water
- Thus enables the house to stay dry from the rain

(d)

Level 1 (0-3m)

Answers will be generalised or with minimal support if any given at all

Reasoning is rather weak and expression may be unclear

A basic answer that has little development. Answers lack examples or other evidence, or it is so sketchy that it adds little support to the answer.

Level 2 (4-6m)

Disagreement or agreement will be supported by appropriate detail. Or, both agreement and disagreement are considered, but support is patchy so that the answer is not full.

Good reasoning and logic in parts of the answer with good expression in places.
Some examples or other evidence will be presented to support in at least one place in the answer.

Level 3 (7-8m)

Answers will be comprehensive and supported by sound knowledge
Both agreement and disagreement are considered and well supported with development of the importance of at least 1 similarity and 1 difference.
Reasoning is clear and logical with good expression of language.
Examples or other evidence to support answers will be extensive.

Suggested answer:

Similarity in formation

- Both are landforms formed by magma ejected from the mantle onto the earth's surface.
- Both are fed by a magma chamber, which is a reservoir of molten rock beneath the earth's crust.

Differences in physical characteristics and nature of eruption

Stratovolcano	Shield volcano
steeper at the top and gentler at the base; Secondary cones may develop as magma from the vent seeps into the sides of the cone and erupts.	gently sloping sides and a broad summit
high-silica lava; more viscous; develop from successive eruptions of lava and pyroclasts (ash, rock fragments and volcanic bombs)	low-silica lava; flows easily and spreads out over a large area before solidifying
Usually explosive	usually not explosive
	common near divergent plate boundaries

2(a)

(i)

Describe

- High throughout the year i.e.: $\geq 30^{\circ}\text{C}$
- Small temp. range i.e.: $< 3^{\circ}\text{C}$ → need to be worked out, unacceptable to write bet. 30 & 33°C

Account for

- Low latitude, high solar angle
- Heat from sun concentrated on a small area

(ii)

Describe

- High total annual i.e.: 2090mm
- Seasonal (dry in DJFMAM, wet in JJASON)

Account for

- SW monsoon – Summer in NH, Winter in SH
- Air from Australia moves to C Asia due to pressure difference
- Picks up moisture from the ocean and brings heavy rain in JJAS
- NE monsoon – Winter in NH, Summer in SH
- Air from C Asia moves to Australia due to pressure difference
- Blows across cold land, no rain

(b)

Formation

- Between the tropics + Over oceans e.g.: Indian / Pacific / Atlantic
- As high ocean surface temp ($>26.5^{\circ}\text{C}$) / heat + moisture from ocean waters are necessary

Movement-

- From water to land e.g.: India Ocean \rightarrow SE of Africa
- Due to Coriolis Effect, deflect to the right in the NH (rotate anti-clockwise), to the left in SH

(c)

1m for diagram that shows direction of (prevailing) wind, windward vs leeward side

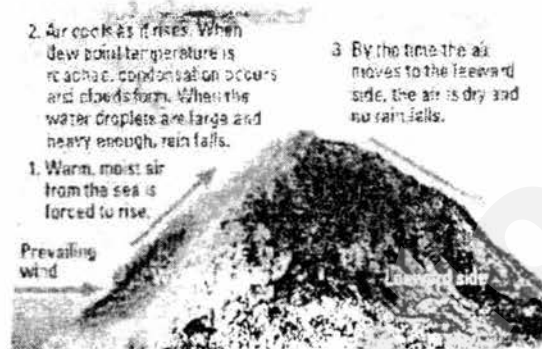

- Wind blows over sea, picking up large amounts of water vapour.
- Warm moist air encounters a mountain or upland area, forcing it to rise.
- As air rises, it cools and dew point temp. is reached. Water vapour condenses to form water droplets and clouds
- Rain falls mostly on windward side
- Leeward side little or no rain, descending air warmed by heat near earth's surface = dry wind aka 'rain shadow effect'

(d)

Level 1 (0-3m)

Answers will be generalised or with minimal support if any given at all

Reasoning is rather weak and expression may be unclear

A basic answer that has little development. Answers lack examples or other evidence, or it is so sketchy that it adds little support to the answer.

Level 2 (4-6m)

Disagreement or agreement will be supported by appropriate detail. Or, both agreement and disagreement are considered, but support is patchy so that the answer is not full.

Good reasoning and logic in parts of the answer with good expression in places.

Some examples or other evidence will be presented to support in at least one place in the answer.

Level 3 (7-8m)

Answers will be comprehensive and supported by sound knowledge

Both agreement and disagreement are considered and well supported with development of the importance of at least 1 human and 1 natural cause.

Reasoning is clear and logical with good expression of language.

Examples or other evidence to support answers will be extensive.

Suggested answer:

Agree

Demand for WOOD/tree-based products such as paper and building materials \rightarrow 1

Demand for FOOD RESOURCES \rightarrow 1, 2

Demand for PRECIOUS MINERALS/manufactured goods \rightarrow 1, 2

1. Deforestation: loss of forests due to the removal or clearance of trees in forested areas.
 - Deforestation causes increase in levels of carbon dioxide in two ways:
 - Fewer trees to absorb carbon dioxide
 - Forests absorb billions of tonnes of carbon dioxide every year via photosynthesis.
 - With deforestation, there are fewer trees/plants to absorb carbon dioxide, leading to an increase in carbon dioxide levels in the atmosphere.
 - Carbon oxidation is the process by which carbon in the soil reacts with oxygen in the atmosphere to form carbon dioxide.
 - Deforestation exposes soil to sunlight which increases soil temperature and the rate of carbon oxidation in soil.

2. Changing land use: as population increases, the demand for industrial, agricultural land also increases. Previously forested land is also converted to urban or built-up areas as people choose to live in cities.
 - Therefore, changes in land use contribute to greenhouse gas emissions.
 - Agriculture
 - Agriculture refers to the practice of cultivating land, producing crops and raising livestock. To meet increasing demand for food
 - Cattle farming contributes to greenhouse gas emissions as cattle releases millions of tonnes of methane into the atmosphere annually, gases as are released from the digestive systems of cattle.

 - Industries
 - Industries refer to the production of goods and services within a country.
 - Secondary Industries, such as manufacturing, involve the burning of fossil fuels that result in greenhouse gas emissions.
 - Greenhouse gases are also released as byproducts when goods are produced.

 - Urbanisation
 - Urbanisation is the process by which an increasing number of people live in urban areas.
 - Large amounts fossil fuels are burnt to provide energy for household activities in urban areas.
 - Such activities include: Heating (not in Singapore, but in temperate countries) Cooling (Air-conditioning) Cooking and Lighting

Thus, deforestation + changing land use increases GHGs → EGHE

Disagree:

1. Variations in solar output
 - higher sunspot activity is linked to higher amounts of solar radiation emitted.

2. Volcanic eruptions
 - When a volcano erupts, large volumes of carbon dioxide, water vapour, sulfur dioxide, dust and ash are released into the atmosphere.
 - Together with dust and ash, these particles reflect solar energy back into space.
 - This results in a cooling influence on regional and global temperatures.

3(a)

(i) (ANY 3)

- Commercial / Intended for sale
 - Large scale (of land)
 - Huge capital required for inputs e.g.: machinery
 - Involves hired labour
- (ii) (ANY 4)
- Unevenly distributed;
 - More on North Island;
 - Mainly in coastal areas;
 - and near main cities. (give examples)
 - Especially on east coast of south island

(b)

Describe (Compulsory):

- Estimated \$66 billion per year to treat obesity related disease

Explain:

- Over-consumption of nutrients can affect most of the body's systems & lead to **OBESITY** related health problems (high blood pressure, coronary heart disease, diabetes, certain cancers)
- Thus, increase country's overall cost of providing healthcare, leaving less resources for other areas of development in USA

Describe (Compulsory):

- Estimated \$390 to \$580 billion loss of economic productivity.

Explain:

- Can result in more **absences from work**, more days of leave taken, due to **OBESITY** related health problems
- Also higher insurance costs & compensation claims to employees

(c) (ANY 2 out of 3 of the physical factors. up to 3m per factor)

Factor	How it affects	
Physical <i>Different crops require different temp., rainfall, soil, drainage & relief</i>	Climate	
	HIGH temp. & HIGH rainfall - more conducive for plant growth - i.e.: in the Tropics, long growing season enables farmer to have 2-3 harvests / year	LOW temp. & LOW rainfall - no food production during winter - however, greenhouses can overcome short growing season
	Soils & drainage	
	FERTILE soil - more productive - i.e.: floodplains, deltas, volcanic areas PROPER soil drainage - more productive	INFERTILE soil - less productive - however, chem. fertilisers can overcome this IMPROPER soil drainage - less productive, hinders growth of crops
Relief		
FLAT land or GENTLE slope - more productive - retains water, allows use of machines LOW altitude - favours most crops	STEEP slope - less productive - water drains off fast, use of machines is limited, soil erosion is more likely to occur - however, terracing can overcome this e.g.: Longji Rice Terraces, China HIGH altitude - favours cool climate crops e.g.: strawberries, tea, coffee	

(d)

Relevant points:

- Agreement that rapid popn growth is an important cause in LDCs
- But acknowledge at least 2 other factors i.e.: physical (e.g.: climate change etc), political (e.g.: poor governance), economic (e.g.: rising demand from BRIC), other social (e.g.: lack of accessibility)
- Examples given MUST be of LDCs

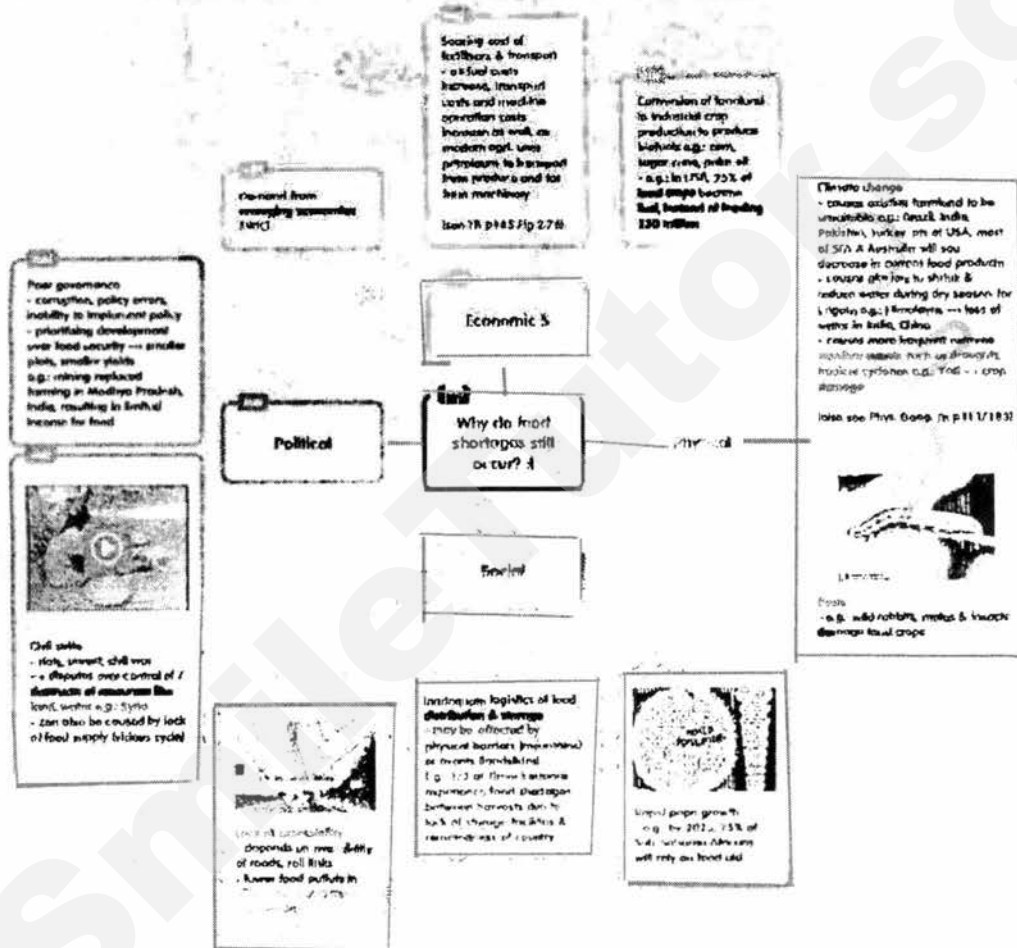
**L1 (0-3)**

- Answer will be generalized or with minimal support if any given at all.
- Reasoning may be rather weak and expression may be unclear.
- Basic answer that has little development, lack examples or other evidences / sketchy examples.

E.g.: I agree, LDCs always lacking in food.

L2 (4-6)

- Disagreement / agreement will be supported by appropriate detail. Or, both disagreement & agreement considered but with patchy support.
- Good reasoning and logic in parts of answer with good expression in places.
- Not a full answer, some examples or other evidence presented in at least 1 place in answer.

E.g.: I agree to some extent, for example in Sub-Saharan Africa. Countries have high birth rate as the people lack family planning.

L3 (7-8)

- Both disagreement & agreement are considered and well supported.
- Reasoning is clear and with good expression.
- Comprehensive answer, supported by sound knowledge. Examples or other evidence extensive.

E.g.: I agree to some extent, for example in Sub-Saharan Africa. Countries have high birth rate as the people lack family planning. However, there are other causes, such as the conversion of farmland to biofuel crop production. In USA, 25% of all food crops grown become biofuel, which can feed 300 million people for 1 year, most of whom are from LDCs. Another cause is civil strife. In a conflict area, farmland may have been destroyed by landmines.

4(a)**(i)**

- Distribution – no. of affected countries had decreased from 1946 / from worldwide to tropical regions only
- 108 countries affected in 2010
- E.g.: Australia is not affected anymore (any other e.g.)
- No. of cases – increased and then decreased / overall decreased
- From 233m (2000) to 225m (2009)
- Death – decreased
- From 1m (2000) to 781,000 (2009)

(ii)

- 176m in Africa
- or 78% of cases worldwide
- possible reason: bed nets are not always effective / used correctly as they should be i.e.: some employed as fishing nets
- possible reason: older antimalarial drugs have become ineffective, as the parasite develops resistance to them
- possible reason: newer artemisinin treatment are unaffordable

(b)

- Overall, increase
- From 26% (2000) of planted areas to 88% (2012) of planted areas
- Slight decrease in Bt corn, from 19% (2000) to 16% (2012)
- Increase in HT corn, from 6% (2000) to 22% (2012)
- Largest increase in Stacked corn, from less than 1% (2000) to 50% (2012)

(c)

- MC: Non leguminous crops (corn, sorghum) benefit from nitrogen generated by leguminous crops (ground nut, soya bean) – improves fertility & increases productivity
- Minimises pests as some crops (garlic, pepper, onions) act as repellent –no crop loss
- Prevents pests & diseases from wiping out all crops in monoculture
- CR: No planting of the same crop on the same piece of land – prevents decrease in soil fertility & increases productivity
- Both: Dependence of 1 crop is prevented as there is larger variety of crops grown – farm is productive every season / different times of the year

(d)

Relevant points:

- Agreement that env. factors are responsible for spread of Malaria
- But disagreement as HIV/AIDS is not dependent on env. factors for its spread i.e.: social or economic factors need to be explained
- Examples given MUST be of LDCs

<p>L1 (0-3)</p> <ul style="list-style-type: none"> • Answer will be generalized or with minimal support if any given at all. • Reasoning may be rather weak and expression may be unclear. • Basic answer that has little development, lack examples or other evidences / sketchy examples. <p>L2 (4-6)</p> <ul style="list-style-type: none"> • Disagreement / agreement will be supported by appropriate detail. Or, both disagreement & agreement considered but with patchy support. • Good reasoning and logic in parts of answer with good expression in places. • Not a full answer, some examples or other evidence presented in at least 1 place in answer. <p>L3 (7-8)</p> <ul style="list-style-type: none"> • Both disagreement & agreement are considered and well supported. • Reasoning is clear and with good expression. • Comprehensive answer, supported by sound knowledge. Examples or other evidence extensive.

FACTORS contributing to its spread

Malaria	HIV/AIDS
<p>Social</p> <ul style="list-style-type: none"> - Lack of proper sanitation: stagnant pools of waste water near settlements are breeding grounds for mosquitoes <p>Economic</p> <ul style="list-style-type: none"> - Limited provision of & access to health care: shortage of drs, lack in rural areas & cost of malaria treatment (ACT) e.g.: In India, 6 drs: 10,000 pax, 4% GDP on health care spending & concentrated in urban areas, ACT unaffordable to poor <p>Environmental</p> <ul style="list-style-type: none"> - Overcrowded living conditions: encourages speed & ease of spread - Poor drainage & stagnant water e.g.: Seepage from Indira Gandhi Canal Project into Rajasthan, India - Effect of climate: temp, rainfall, RH (p208 Fig 3.52), post-monsoon period e.g.: 2006-9, Pakistan 	<p>Social</p> <ul style="list-style-type: none"> - Social stigma related to the disease: hinders early intervention Education: lack of awareness & sexuality awareness education. e.g.: Nigeria - Lifestyle choices: drug injection, sharing needles, unprotected sex / sexually active at young age / multiple sexual partners Lapses in medical practices: mistakes, corruption & negligence e.g.: 2011, 130,000 patients in USA exposed to tainted blood <p>Economic</p> <ul style="list-style-type: none"> - Vice trades: illegal drugs & commercial sex Mobility: more likely to get involved in risk-taking behaviours, spread in shorter period of time to more pax e.g.: 2010, infected Australians had travelled to Papua New Guinea



ST JOSEPH'S INSTITUTION

**PRELIMINARY EXAMINATION 2017
(SECONDARY 4)**

GEOGRAPHY

2236/01

Paper 1

18 August 2017

Additional Materials Insert
 Writing Paper
 Topographical Map

**1 hr 40 minutes
(8.00am – 9.40am)**

READ THESE INSTRUCTIONS FIRST

Write your Class, index number and name on all the work you hand in.
 Write in dark blue or black pen on both sides of the paper.
 Do not use paper clips, highlighters, glue or correction fluid.

Section A

Answer Question 1.

Section B

Answer **one** question.

Write all answers on the writing paper provided.
 Candidates are encouraged to support their answers with the use of relevant examples.
 Sketch maps and diagrams should be drawn whenever they serve to illustrate an answer.

Insert contains

Fig. 1 for Question 1(a).

Fig. 2 for Question 1 (b).

Table 3 for Question 1(c).

At the end of the examination, fasten all your work securely together.
 The number of marks is given in brackets [] at the end of each question or part question.

This document consists of **10** printed pages, including the Cover Page and Insert.

[Turn over]

Section A

This question is compulsory.

- 1 Students who lived in Thailand were interested in the development of tourism at Chiang Mai, a city in the north of the country. They decided to investigate why tourists came to Chiang Mai and what impact tourism had on people who lived in the city. Their two hypotheses were:

Hypothesis 1: Physical attractions brought more tourists to Chiang Mai than human attractions.

Hypothesis 2: Tourism has a positive rather than negative impact on people who live in Chiang Mai.

- (a) The students decided to use the questionnaire, shown in Fig. 1 (Insert), to investigate Hypothesis 1.
- (i) The answers to Question 1 (Which continent do you come from?) are shown in Table 1 below.

Table 1
Answers to Question 1
Continent & Number of tourists

Continent	Number of tourists
Asia	26
Africa	4
Oceania	8
Europe	14
North America	12
South America	6
Total	70

What conclusions can you make from Table 1 about the origin of tourists visiting Thailand?

[2]

- (ii) The answers to Question 2 (What are the main physical attractions you are visiting whilst in Chiang Mai?) and Question 3 (What are the main human attractions you are visiting whilst in Chiang Mai?) are shown in Table 2.

Table 2
Answers to Questions 2 and of tourist questionnaire

Q2 Physical Attractions	Number of visits made
Mae Kiang waterfall	35
Doi Inthanon mountain	48
Fang hot springs	17
Botanical Gardens	12
Elephant camp	34
Orchid and butterfly farms	6
Ob Luang gorge	18
Total	
Q3 Human Attractions	Number of visits made
Hill tribe villages	23
National museum	10
Shopping at night bazaar	45
Buddhist temples	37
Bhubing Palace	6
Muang Kung earthenware village	11
Royal pagodas	8
Total	

What type of graph can best show the answers to questions 2 and 3? Describe how you would draw this type of graph. [3]

- (iii) What are some of the limitations of asking Questions 2 & 3 in trying to test Hypothesis 1? [3]
- (iv) Was their Hypothesis 1: **Physical attractions brought more tourists to Chiang Mai than human attractions proven?** Support your answer with evidence from Table 2. [2]
- (b) The students used a different questionnaire to investigate the impact of tourism on people who lived in Chiang Mai. The questionnaire is shown in Fig. 2 (Insert).
- (i) The students used a systematic sampling technique to obtain answers to their questionnaire. Suggest how they might have done this and state 2 advantages of using this technique. [3]
- (ii) Do you think that it was a good idea to ask people for their first and second choices for Questions 2 and 3 in the survey? Explain your decision. [2]

- (c) The answers to Question 2 (What do you think are the main positive impacts of tourism in Chiang Mai?) and Question 3 (What do you think are the main negative impacts of tourism in Chiang Mai) are shown in Table 3 (Insert).

The students devised this simple formula to work out which impacts were most important.

Positive impact: More jobs and income

1st choice $27 \times 2 = 54$

2nd choice $15 \times 1 = 15$

Total score 69

- (i) Use this formula to work out the total score for air pollution. Show all working. [1]
- (ii) What conclusion can you make about Hypothesis 2: Tourism has a positive rather than negative impact on people who live in Chiang Mai? Support your decision with evidence from Table 3 (Insert 3) [2]
- (iii) What did the local people consider to be the 2 most negative impacts of tourism? Suggest reasons why they did so. [3]
- (d) Describe how the students could carry out fieldwork to investigate the impact of traffic congestion. [4]

Section B

Answer one question from this section.

2. (a) Fig. 3 shows a scene at a beach.



<http://www.signsgoldcoast.com.au/signage/safety-wayfinding-signs>

Fig. 3

- (i) Describe the type of waves associated with signs seen in Figure 3. [3]
- (ii) Evaluate any 2 appropriate coastal protection measures that may be used in this area to protect the beach. [5]

- 3 (a) Study the 1: 25 000 map extract of Tamarin (Mauritius).

Using map evidence, explain why area bounded by Northings 81 to 91 and eastings 82 to 84 is suitable for tourism. [5]

- (b) Tables 4 and 5 show some tourism statistics for the country of New Zealand.

Table 4

Overseas Visitor arrivals for 2013 - 2016							
	2013	2014	2015	2016	2014	2015	2016
	Annual % change						
Oceania	1,311,872	1,359,120	1,415,588	1,514,080	3.6	4.2	6.9
Asia	528,624	575,200	681,568	814,640	8.8	18.5	19.5
Americas	264,576	285,664	307,024	348,192	8.0	7.5	13.4
Other	88,880	98,048	88,624	89,472	10.3	-9.6	1.0
Total	2,611,377	2,752,257	2,947,901	3,255,463	5.4	7.1	10.4

<http://www.tdc.co.tt/index.php>

Table 5

Total Tourism Expenditure by tourists				
Year	Total Tourism Expenditure \$ (million)	Annual percentage change	Gross Domestic Product \$ (million)	International tourism as a % of total exports
2013	26 947	1.3	62 766	15.8
2014	28 039	4.1	67 002	15.4
2015	30 935	10.3	67 514	17.9
2016	34 699	12.2	70 144	20.7

<http://www.tdc.co.tt/index.php>

- (i) Describe and suggest reasons for the trend of visitor arrivals to New Zealand from 2013 to 2016. [4]
- (ii) With reference to Tables 4 and 5, explain how tourism is a boon and a risk to the New Zealand economy. [4]
- (c) Explain, with the use of examples, how budget airlines have contributed substantially to the growth of tourism. [4]
- (d) "Tourism activities are having a devastating effect on the environment."
How far do you agree? Use examples to support your answer. [8]

Insert

Fig. 1 for Question 1(a).

Tourist questionnaire

We are doing a tourism survey as part of our Geography coursework. Please will you answer the following questions?

1. Which continent do you come from?

- | | | |
|----------------------------------|--|--|
| <input type="checkbox"/> Asia | <input type="checkbox"/> Africa | <input type="checkbox"/> Europe |
| <input type="checkbox"/> Oceania | <input type="checkbox"/> North America | <input type="checkbox"/> South America |

2. What are the main physical attractions you are visiting whilst in Chiang Mai?

- | | |
|--|---|
| <input type="checkbox"/> Mae Klang waterfall | <input type="checkbox"/> Doi Inthanon Mountain |
| <input type="checkbox"/> Fang Hot Springs | <input type="checkbox"/> Botanical Gardens |
| <input type="checkbox"/> Elephant camp | <input type="checkbox"/> Orchid and Butterfly farms |
| <input type="checkbox"/> Ob Luang Gorge | |

3. What are the main human attractions you are visiting whilst in Chiang Mai?

- | | |
|---|---|
| <input type="checkbox"/> Hill tribe villoges | <input type="checkbox"/> National museum |
| <input type="checkbox"/> Shopping at the night bazaar | <input type="checkbox"/> Buddhist temples |
| <input type="checkbox"/> Bhubing Palace | <input type="checkbox"/> Muang Kung Earthenware village |
| <input type="checkbox"/> Royal pagodas | |

Thank you for your time.

Insert

Fig. 2 for Question 1 (b)

Local people questionnaire

We are doing a tourism survey as part of our Geography coursework. Please will you answer the following questions?

1. Do you live in Chiang Mai?

Yes

No

(Finish interview if 'No')

2. What do you think are the main positive impacts of tourism in Chiang Mai?
Number your first and second choices '1' and '2'.

More jobs and income

Improved standard of living

More modern services

Cleaner environment

Improved infrastructure e.g. airport, roads

Reduction in crime

Greater range of goods in shops

Local people have greater global awareness

3. What do you think are the main negative impacts of tourism in Chiang Mai?
Number your first and second choices '1' and '2'.

Noise pollution

Air pollution

Traffic congestion

Increase in crime

Decline of traditional culture and way of life

Increase in litter

Increase in cost of living

Destruction of natural environment for hotels, shops etc.

4. Overall do you think tourism has a positive or negative impact in Chiang Mai?

Positive

Negative

Thank you for your time.

Insert

Table 3 for Question 1(c)

Answers to Questions 2, 3 & 4 of local people questionnaire

Q2 Positive impacts of tourism	First choice	Second choice	Total score using formula
More jobs and income	27	15	69
Improved standard of living	7	12	25
More modern services	2	6	10
Cleaner environment	3	1	7
Improved infrastructure	8	6	22
Reduction in crime	1	12	14
Greater range of goods in shops	6	6	18
Local people have greater global awareness	7	3	17
Total	61	61	

Q3 Negative impacts of tourism	First choice	Second choice	Total score using formula
Noise pollution	4	7	15
Air pollution	16	10	
Traffic congestion	17	14	48
Increase in crime	3	4	10
Decline of traditional culture and way of life	7	5	19
Increase in litter	3	7	13
Increase in cost of living	4	9	17
Destruction of natural environment	7	5	19
Total	61	61	

Q4 Overall impact of tourism	Answers
Positive	53
Negative	8



ST JOSEPH'S INSTITUTION

**PRELIMINARY EXAMINATION 2017
(SECONDARY 4)**

GEOGRAPHY

2236/02

Paper 2

29 August 2017

Additional Materials Insert
 Writing Paper

1 hr 30 minutes
(8.00am – 9.30am)

READ THESE INSTRUCTIONS FIRST

Write your Class, index number and name on all the work you hand in.
Write in dark blue or black pen on both sides of the paper.
Do not use paper clips, highlighters, glue or correction fluid.

Section A

Answer **one** question.

Section B

Answer **one** question.

Write all answers on the writing paper provided.
Candidates are encouraged to support their answers with the use of relevant examples.
Sketch maps and diagrams should be drawn whenever they serve to illustrate an answer.

Insert contains

Fig. 5A and Fig. 5B for Question 2 (b)

Fig. 9 and 10 for Question 4 (a)

Fig. 11 for Question 4 (b)

At the end of the examination, fasten all your work securely together.
The number of marks is given in brackets [] at the end of each question or part question.

This document consists of 11 printed pages, including the Cover Page and Insert.

[Turn over]

Section A

Answer one question from this section.

- 1 (a) (i) Fig. 1 below shows the relationship between pressure and altitude.

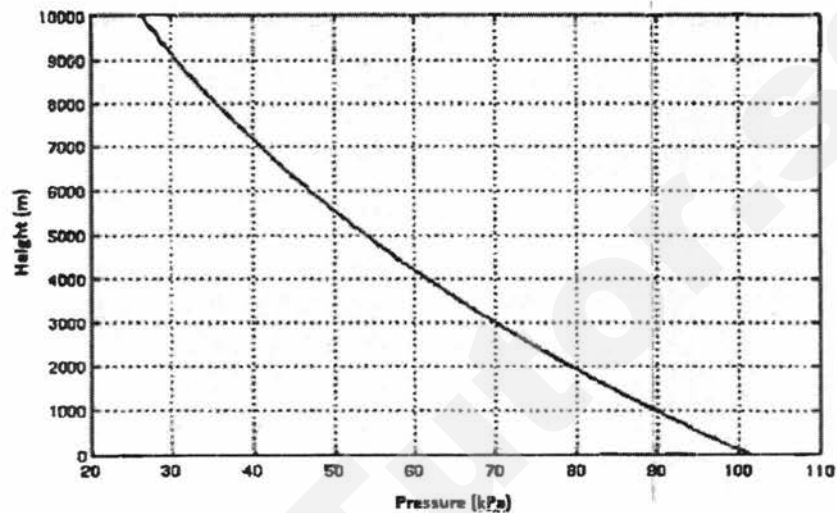

<https://physics.stackexchange.com>

Fig. 1

Describe and explain the relationship between altitude and pressure [3]

- (ii) The simplified isobar map for East Asia and Australia in December is shown in Fig.2 below.

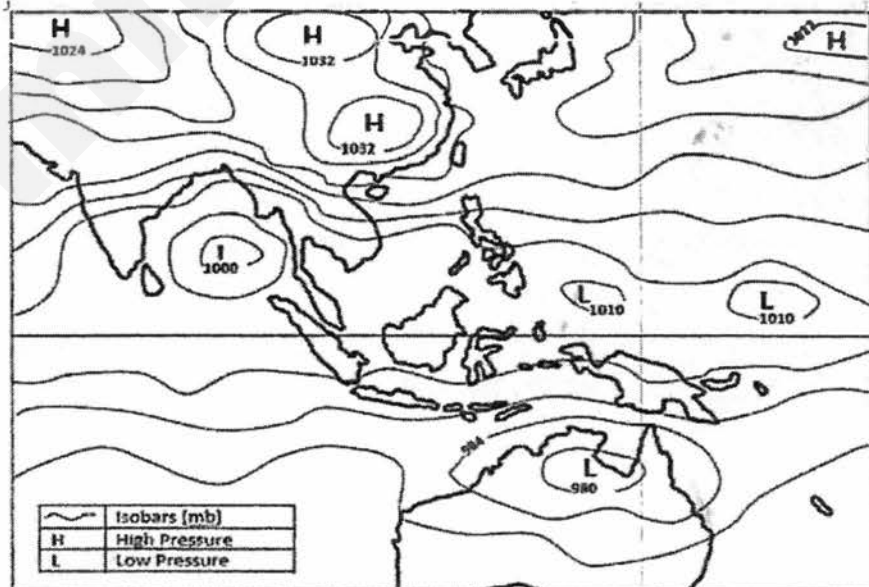

Adapted: <http://www.vagaries.in/2012>

Fig. 2

Based on the information in Fig. 2, account for the high and low pressure cells in the region shown and the likely wind pattern that will form.

[5]

Need a home tutor? Visit smiletutor.sg

(b) Explain how the presence of cloud cover can affect the daily temperature range. [4]

(c) Study Fig. 3, which shows the path of a tropical storm.

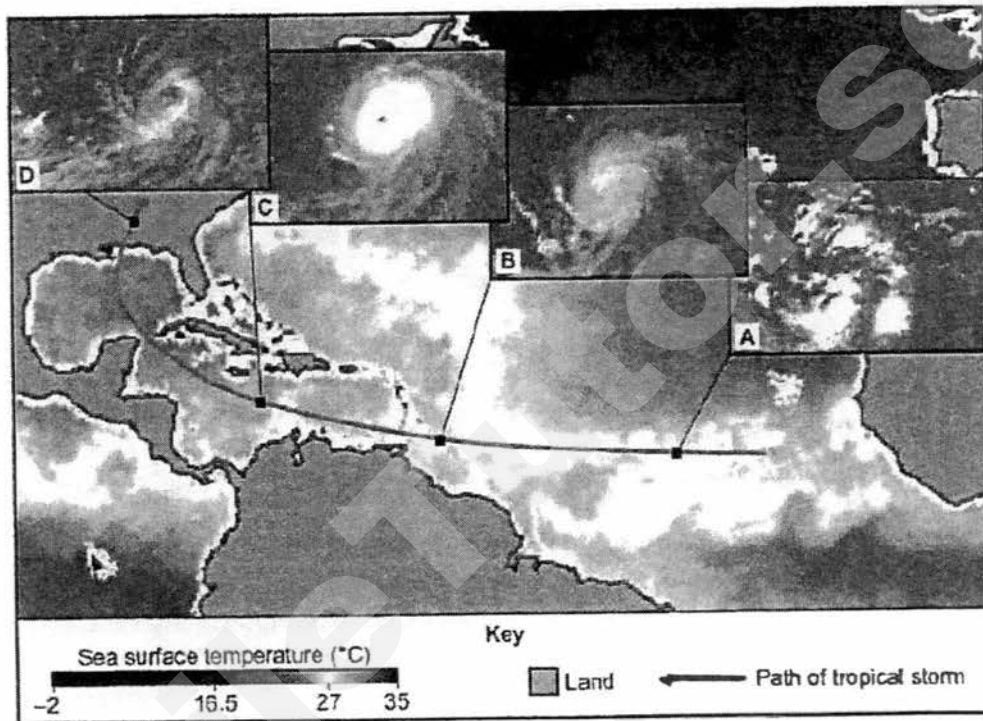

Source: © Commonwealth of Australia (2008), Bureau of Meteorology
Fig. 3

With the help of Fig. 3, explain the development of the tropical storm from A to D. [5]

(d) 'National measures are more effective than international agreements in reducing the impact of climate change'.
To what extent do you consider this statement to be true? Use examples to support your answer. [8]

- 2 (a) Study Fig. 4A, which shows the location of Moscow and Singapore and Fig. 4B, which shows the climographs of these 2 cities.



Fig. 4A

Moscow: 55°N 37°E
 Mean annual temperature = 5.0°C
 Total annual precipitation = 688mm

Singapore: 1.3°N 103°E
 Mean annual temperature = 26.9°C
 Total annual precipitation = 2275mm

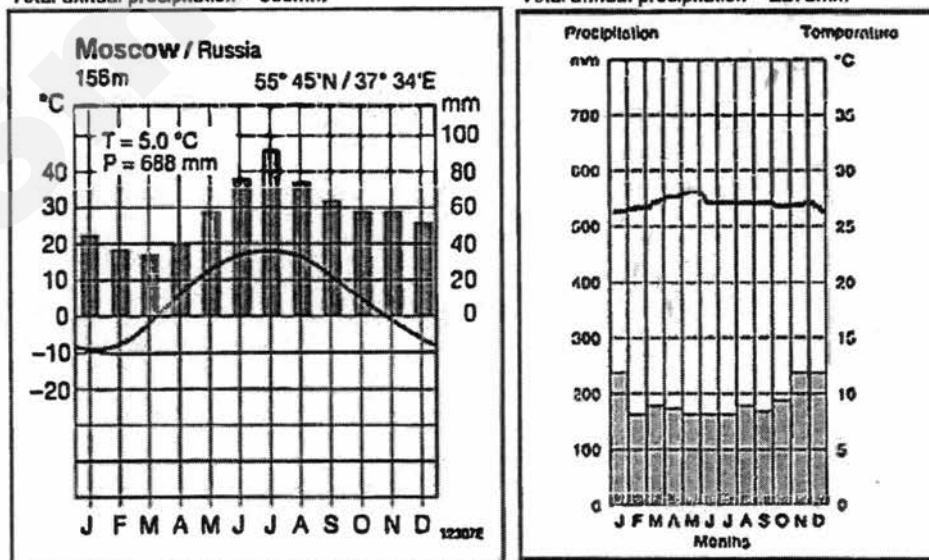

<https://en.climate-data.org>

Fig. 4B

- (i) With reference to Fig. 4A and Fig. 4B, compare the rainfall and temperature of Moscow and Singapore.

[4]

Need a home tutor? Visit smiletutor.sg

- (ii) Account for the temperatures of Moscow and Singapore. [4]
- (b) Study Fig. 5A (Insert), which shows a volcanic hazard risk map for an area in California in the United States of America (USA) and Fig. 5B (Insert), which is a write-up on the Lassen Volcanic National Park.
- (i) Based on the information in Fig. 5A and Fig. 5B, what type of volcano will likely form in the area shown? Explain your answer. [4]
- (ii) With reference to Fig. 5A and Fig.5B and studies you have made, describe the type and level of risk for towns like Westwood and Bumey as compared to Old Station and Viola. [5]
- (c) "Since earthquakes are hard to predict, it is better to invest in response measures than preparedness measures."
To what extent do you consider this statement to be true? Use examples to support your answer. [8]

Section B

Answer one question from this section.

3. (a) (i) Fig. 6 shows the amount of meat and seafood imported into Singapore from 2004 to 2013.

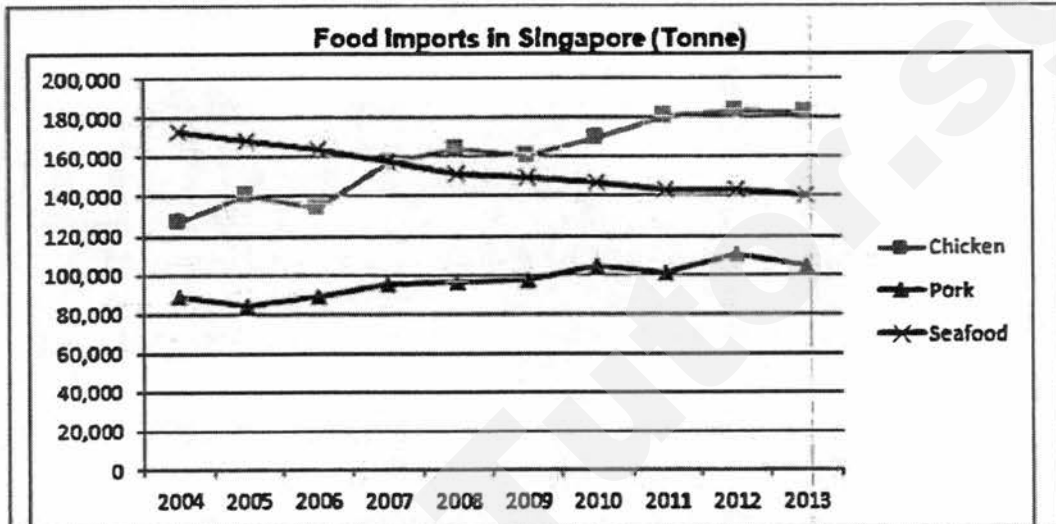

Source: Agri-Food and Veterinary Authority of Singapore

Fig. 6

With reference to Fig. 6, compare and account for the trends in demand for chicken, pork and seafood in Singapore. [5]

- (ii) The targets for local production of 3 key food items are shown in Fig. 7 below.

Key food items	2020 Local production targets	2014 production
Hen shell eggs	30%	25%
Leafy vegetables	10%	12%
Fish	15%	8%

Source: Agri-Food and Veterinary Authority of Singapore

Fig. 7

What are some of the challenges in meeting the production targets and suggest possible strategies that can be used to overcome such challenges? [5]

- (b) Fig.8 shows the amount of farm land used by countries for the production of genetically modified crops in 2000 and 2006

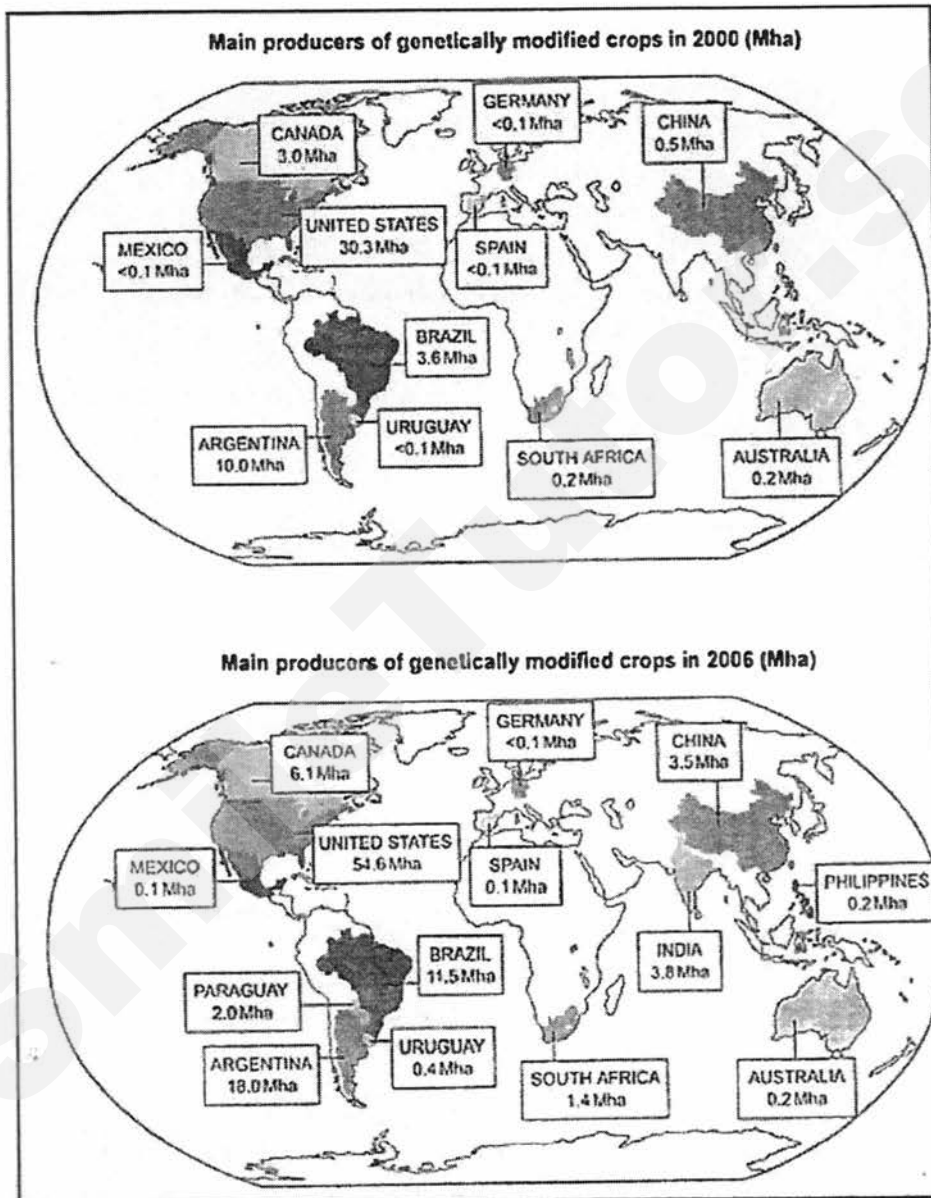

<http://www.economist.com/blogs/dailychart/2011>

Mha = million hectares

Fig. 8

- (i) With reference to Fig. 8, describe the changes to the production and location of genetically modified crops and the area they cover between 2000 and 2006. [4]
- (ii) Suggest reasons why countries like India, Paraguay and Philippines are cultivating GM crops. [3]

- (c) "Adopting modern technology in agriculture is more effective in increasing food production than using agricultural strategies."

To what extent do you consider this statement true? Use examples to support your answer.

[8]

4. (a) Study Fig. 9 (Insert) which is a map of Africa showing trends of drought areas in Africa and Fig. 10 (Insert) which shows countries in Africa facing a food shortage problem.

(i) Using Fig. 9 and Fig.10, describe and account for the location of areas in Africa facing food security issues. [4]

(ii) What are the impacts of food shortages on the people and countries in Africa? [5]

- (b) Study Fig. 11 (Insert), which shows the mortality rates of males due to cardiovascular disease (CVD).

(i) Describe the distribution of mortality rates of males due to CVD around the world. [3]

(ii) Suggest how social and economic factors could be reasons for the occurrence of CVD in these countries. [5]

- (c) "The efforts of governments in managing the spread of diseases cannot succeed without the cooperation of individuals and communities."

To what extent do you consider this statement true? Give evidence to support your answer. [8]

Insert

Fig. 5 A for question 2 (b)

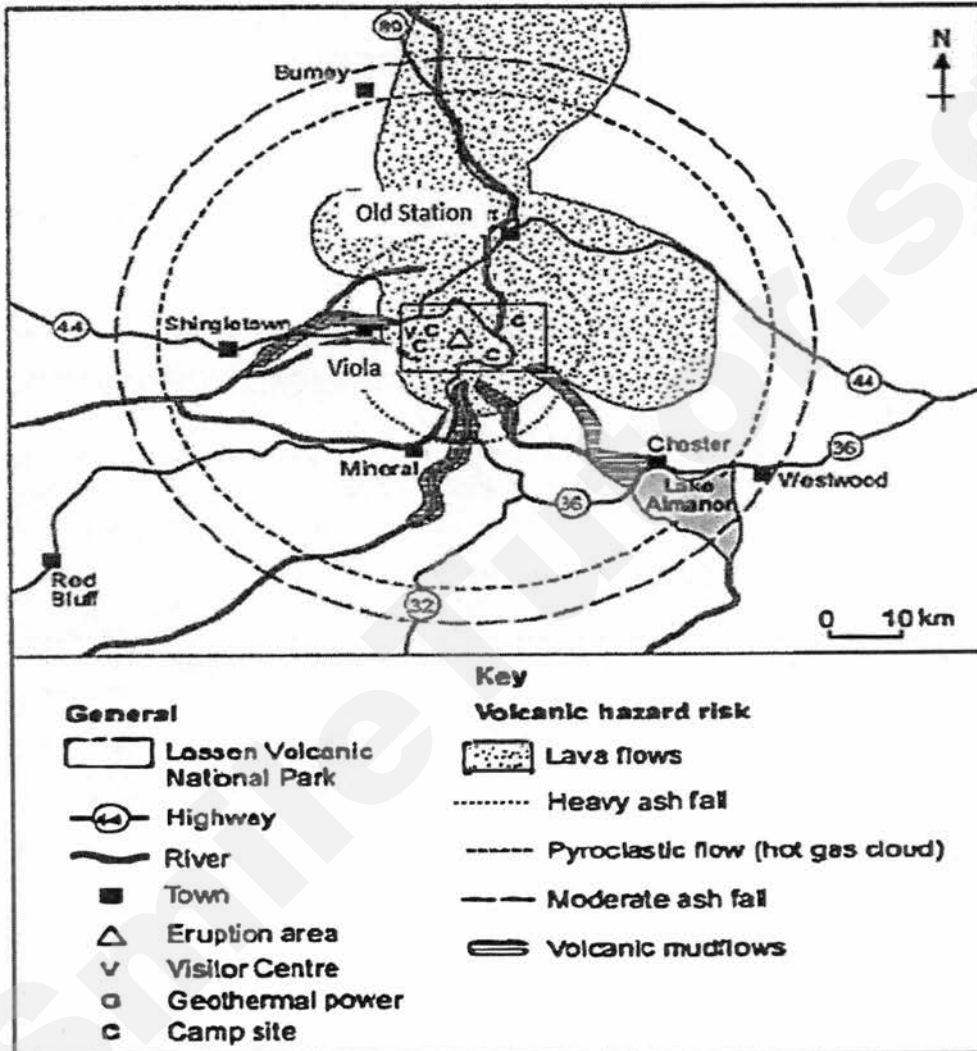

<https://calisphere.org>

Fig. 5B for Question 2 (b)

The source of heat for volcanism in the Lassen area is subduction off the Northern California coast of the Gorda Plate diving below the North American Plate. The area surrounding Lassen Peak is still active with boiling mud pots, stinking fumaroles, and churning hot springs. Starting in May 1914 and lasting until 1921, a series of major explosive eruptions occurred on Lassen. These events created a new crater, and released lava and a great deal of ash.

Source: US Geological Survey

Need a home tutor? Visit smiletutor.sg

Insert

Fig.9 and Fig. 10 for Question 4 (a)

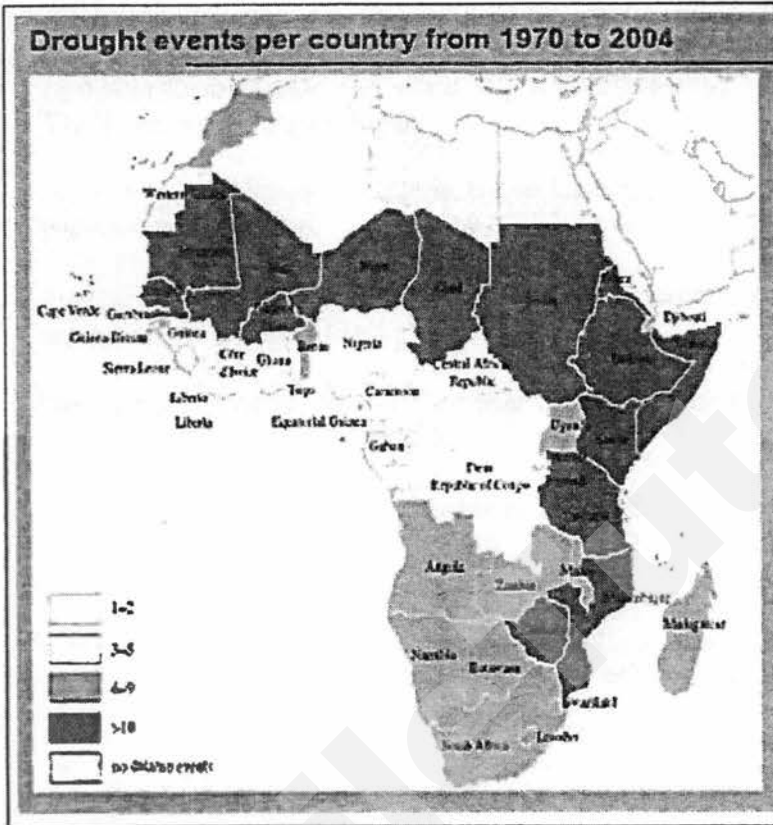

Increasing frequency and severity of drought witnessed in the African continent.

Two thirds of Africa classified as either deserts or drylands

Current climate scenarios – driest regions of the world will become drier

Fig. 9

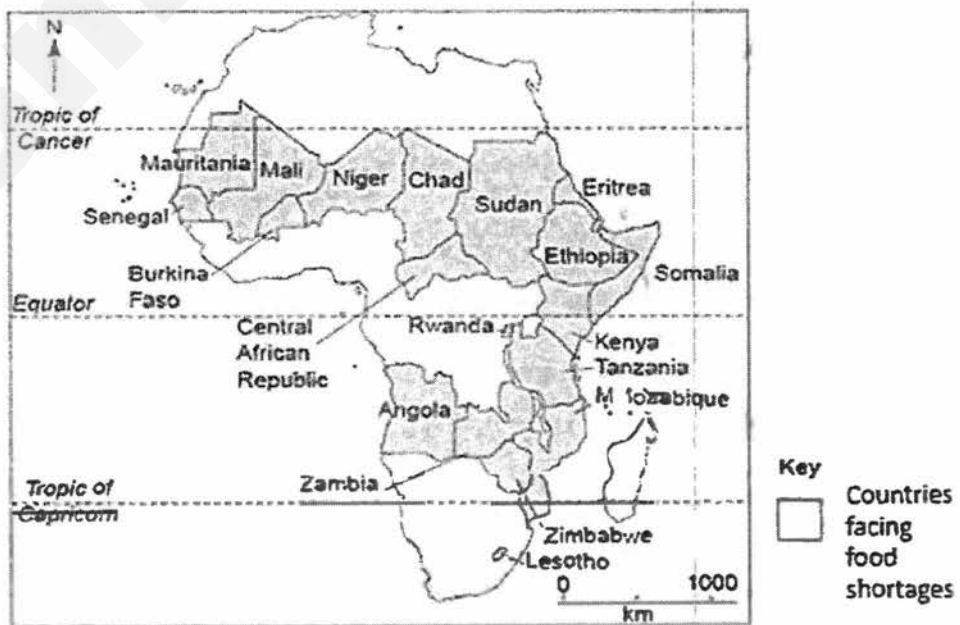
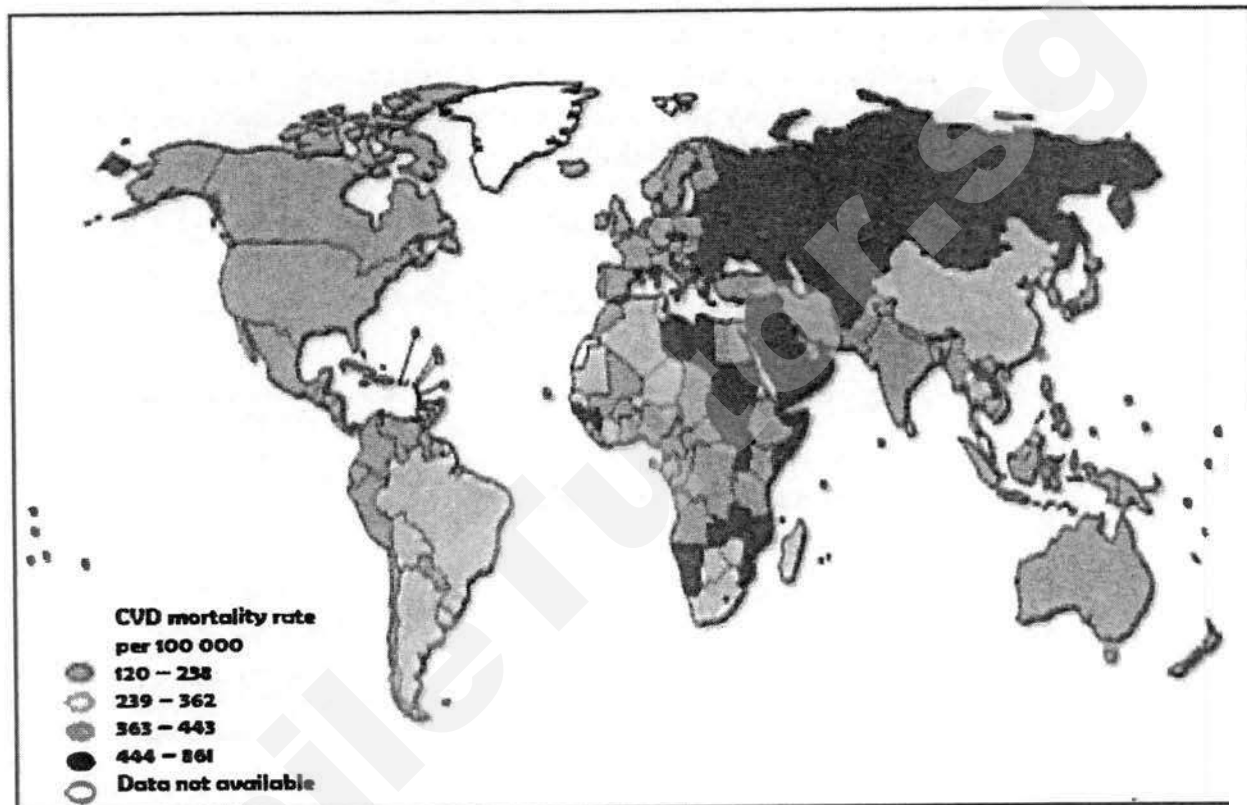

Fig. 10

Insert

Fig. 11 for question 4 (b)



Global Atlas on CVD:World Health Organisation



ST JOSEPH'S INSTITUTION

**PRELIMINARY EXAMINATION 2017
(SECONDARY 4)**

GEOGRAPHY

2236/01

Paper 1

18 August 2017

Additional Materials

Inserts

1 hr 40 minutes

Writing Paper

(8.00am – 9.40am)

Topographical Map

READ THESE INSTRUCTIONS FIRST

Write your Class, index number and name on all the work you hand in.

Write in dark blue or black pen on both sides of the paper.

Do not use paper clips, highlighters, glue or correction fluid.

Section A

Answer Question 1.

Section B

Answer **one** question.

Write all answers on the writing paper provided.

Candidates are encouraged to support their answers with the use of relevant examples.

Sketch maps and diagrams should be drawn whenever they serve to illustrate an answer.

Insert contains

Fig. 1 for Question 1(a).

Fig. 2 for Question 1 (b).

Table 3 for Question 1(c).

At the end of the examination, fasten all your work **securely together**.

The number of marks is given in brackets [] at the end of each question or part question.

This document consists of **10** printed pages, including the Cover Page and Insert.

[Turn over]

Section A

Need a home tutor? Visit smiletutor.sg

This question is compulsory.

- 1 Students who lived in Thailand were interested in the development of tourism at Chiang Mai, a city in the north of the country. They decided to investigate why tourists came to Chiang Mai and what impact tourism had on people who lived in the city. Their two hypotheses were:

Hypothesis 1: Physical attractions brought more tourists to Chiang Mai than human attractions.

Hypothesis 2: Tourism has a positive rather than negative impact on people who live in Chiang Mai.

- (a) The students decided to use the questionnaire, shown in Fig. 1 (Insert), to investigate Hypothesis 1.
- (i) The answers to Question 1 (Which continent do you come from?) are shown in Table 1 below.

Table 1
Answers to Question 1
Continent & Number of tourists

Continent	Number of tourists
Asia	26
Africa	4
Oceania	8
Europe	14
North America	12
South America	6
Total	70

What conclusions can you make from Table 1 about the origin of tourists visiting Thailand? [2]

Highest no of tourists come from nearer countries/Asia
(Asia – 26 vs 6 fr S. America and 12 fr N America)
Least no of tourists come from Africa (4)

- (ii) The answers to Question 2 (What are the main physical attractions you are visiting whilst in Chiang Mai?) and Question 3 (What are the main human attractions you are visiting whilst in Chiang Mai?) are shown in Table 2 below.

Table 2
Answers to Questions 2 and of tourist questionnaire

Q2 Physical Attractions	Number of visits made
Mae Kiang waterfall	35
Doi Inthanon mountain	48
Fang hot springs	17
Botanical Gardens	12
Elephant camp	34
Orchid and butterfly farms	6
Ob Luang gorge	18
Total	[]
Q3 Human Attractions	Number of visits made
Hill tribe villages	23
National museum	10
Shopping at night bazaar	45
Buddhist temples	37
Bhubing Palace	6
Muang Kung earthenware village	11
Royal pagodas	8
Total	[]

What type of graph can best show the answers to questions 2 and 3? Describe how you would draw this type of graph.

Comparative bar graph. 1m

X-axis – Total Physical & Human attractions side by side

Y-axis – number of visits made

Use different colour/shading for physical and human attractions. 2m

- (iii) What are some of the limitations of asking Questions 2 & 3 in trying to test Hypothesis 1? [3]

The phrase, 'you are visiting' may not indicate an actual visit as it is just a possibility/intent. This is therefore not the same as stating the response as 'number of visits made'.

There may be attractions that the tourists went to that were not listed, so the data may not be reliable.

The number of visits made to a physical/human attraction may not prove that it is the reason why tourists visit Chiang Mai

Some of the lesser known attractions, especially those not known to the tourists, may not have many visitors and hence affect the response /data.

- (iv) Was their Hypothesis 1: **Physical attractions brought more tourists to Chiang Mai than human attractions proven?** Support your answer with evidence from Table 2. [2]

Yes

There were 170 visits to physical attractions compared to 140 visits to human attractions

- (b) The students used a different questionnaire to investigate the impact of tourism on people who lived in Chiang Mai. The questionnaire is shown in Fig. 2 (Insert).

- (i) The students used a systematic sampling technique to obtain answers to their questionnaire. Suggest how they might have done this and state 2 advantages of using this technique. [3]

They can interview every n th person/regular intervals eg 1 person every 15 minutes 1m

- Quicker, easier and more convenient to carry out than random sampling and can be more accurate because it avoids the remote possibility that the random sample selects too many examples from one part of the distribution

- Ensures good coverage of an area/number of possible interviewees

- Accurately reflects continuous changes in variables

- Avoids some element of personal bias when selecting respondents any 2 = 2m

- (ii) Do you think that it was a good idea to ask people for their first and second choices for Questions 2 and 3 in the survey? Explain your decision. [2]

Yes, it makes the data more manageable

It prioritises respondents' ideas

It stops them from listing everything

To see if more than one positive/negative

Hard to choose just one idea

No : respondents may have more than 2 choices

Not much data can be collected

Information not required for hypothesis any 2 = 2m

- (c) The answers to Question 2 (What do you think are the main positive impacts of tourism in Chiang Mai?) and Question 3 (What do you think are the main negative impacts of tourism in Chiang Mai?) are shown in Table 3 (Insert).

The students devised this simple formula to work out which impacts were most important.

Positive impact: More jobs and income

1st choice $27 \times 2 = 54$

2nd choice $15 \times 1 = 15$

Total score 69

- (i) Use this formula to work out the total score for air pollution. Show all working.

Need a home tutor? Visit smile.tutor.sg

1st choice : 16 x 2 = 32

2nd choice: 10 x 1=10

Total score = 42

- (ii) **What conclusion can you make about Hypothesis 2: Tourism has a positive rather than negative impact on people who live in Chiang Mai? Support your decision with evidence from Table 3 (Insert 3)** [2]
 Generally true – tourism has a positive impact on people living in Chiang Mai
 Evidence: 53 thought it was positive as against 8 who thought it was negative 1m
 BUT the total score of the positive and negative impacts are the same (183). This suggests that while the respondents felt that tourism has brought beneficial impacts like jobs and improved standard of living, the negative impacts are of concern too. 1m
- (iii) **What did the local people consider to be the 2 most negative impacts of tourism? Suggest reasons why they did so.** [3]
 Traffic congestion is a very visible negative impact. It affects their daily lives in terms of slowing down their movement and affects productivity. It also leads to stress and **accidents**.
 Air pollution from planes, vehicles and **boats make** the air toxic, leading to breathing problems and ill health.
- (d) **Describe how the students could carry out fieldwork to investigate the impact of traffic congestion.** [4]
 Carry out a traffic survey on a few main streets at different times of the day (especially peak and non-peak hours).
 Eg. Tally, 4 times a day, both sides of roads in pairs

 Compile a questionnaire to ask drivers, pedestrians, officials to ask questions like:
 What time is traffic congestion the worst?
 How long does it take you to reach your school/office every day – when there is a jam/no jam?

 *Observation of the area in terms of for eg. waiting time for public transport, air pollution, noise pollution and record using a bi-polar survey scale.

Section B

Answer one question from this section.

2. (a) Fig. 3 shows a scene at a beach.



<http://www.signsgoldcoast.com.au/signage/safety-wayfinding-signs>

Fig. 3

- (i) Describe the type of waves associated with signs seen in Figure 3. [3]

Destructive waves
 Large, high waves
 Backwash more powerful than swash
 Wave frequency >10 waves per minute

- (ii) Evaluate any 2 appropriate coastal protection measures that may be used in this area to protect the beach. [5]

Breakwaters (large stones that are cemented) help to break the force of oncoming waves. Built parallel to coast, some distance offshore.

It creates zone of calm water behind and beach materials can be deposited to form beaches. This allows for some usage of the calm area behind the breakwaters.

However, they are aesthetically unappealing and costly to build. They also protect the coast unevenly as only the area behind it are protected. The zones away from the breakwaters will continue to be eroded by destructive waves.

Seawalls made of concrete or stone built parallel to the coast. They absorb some of the wave energy.

However, they are costly to build and maintain. Also, they can only absorb and reflect some of the wave energy. The powerful backwash can erode the base of the wall and lead to their collapse.

** Main problem of high energy waves must be addressed

Other possible measure; Gabions, Beach nourishment and groynes

Coral reefs and mangroves – **subject to conditions**

Need a home tutor? Visit smiletutor.sg

(b) Fig. 4 shows the distribution of mangrove forests around the world.

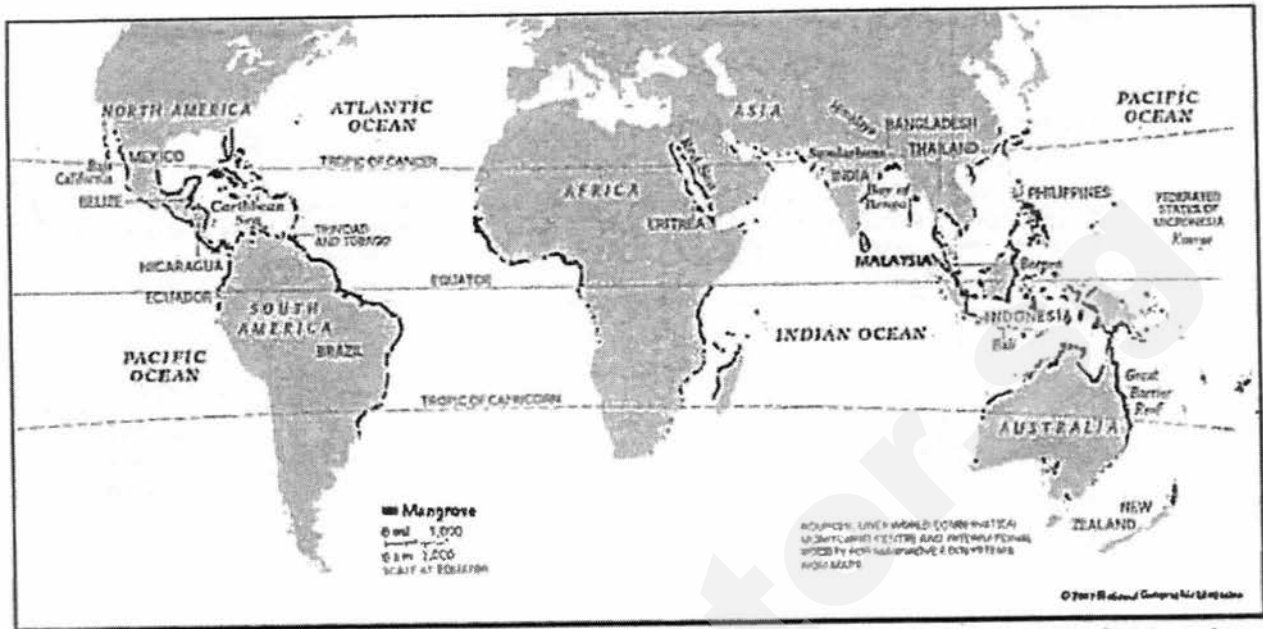

<http://resourcemanagement.thefieldworker>

Fig. 4

(i) Describe and explain the global distribution of mangroves. [4]

Found mainly along coastal areas of countries between the Tropics of Cancer and Capricorn

Areas include S-E Asia, Sri Lanka, east India, Bangladesh, west Madagascar, east Africa, around the Red Sea, eastern coast of S. America, central America and northern Australia & Pacific islands
Mangroves are tropical vegetation, being evergreen and require warmer temperatures.

They are adapted to coastal conditions of mud/silt and saline water.

(ii) What are the natural and human threats to mangrove forests? [5]

Natural threats :

2m

Storm /destructive waves/tsunamis - undermine the fine sediment in which the mangroves grow. This can prevent seedlings from taking root and wash away nutrients essential for mangrove ecosystems.

Climate change. Mangrove forests require stable sea levels for long-term survival. They are therefore extremely sensitive to current rising sea levels caused by global warming and climate change.

Diseases and pests that include grazing animals, crabs, parasites and insects that may increase with warmer climate.

Human threats:

3m

Clearing: Mangrove forests have often been seen as unproductive and smelly, and so cleared to make room for agricultural land, human settlements and infrastructure (such as harbours), and industrial areas. More recently, clearing for tourist developments, shrimp aquaculture, and salt farms has also taken place. This

clearing is a major factor behind mangrove loss around the world.

Overharvesting: Mangrove trees are used for firewood, construction wood, wood chip and pulp production, charcoal production, and animal fodder.

River changes: Dams and irrigation reduce the amount of water reaching mangrove forests, changing the salinity level of water in the forest. If salinity becomes too high, the mangroves cannot survive. Freshwater diversions can also lead to mangroves drying out. In addition, increased erosion due to land deforestation can massively increase the amount of sediment in rivers. This can overcome the mangrove forest's filtering ability, leading to the forest being smothered.

Pollution: Fertilizers, pesticides, and other toxic man-made chemicals carried by river systems from sources upstream can kill animals living in mangrove forests, while oil pollution can smother mangrove roots and suffocate the trees.

- (c) "The loss of mangroves and coral reefs ~~will have~~ more devastating consequences to the economy than the environment."

How far do you agree? Use examples to support your answer.

[8]

Economic impacts:

Loss of revenue from sale of timber and other products from mangroves eg. S.E Asia

Loss of revenue from fishing and aquaculture industries eg. Vietnam

Loss of revenue from tourism activities that visit coral reefs and mangroves eg. Indonesia, Philippines

Environment impacts:

Loss of habitat for plant and animal species in mangrove and coral reef ecosystems

Greater erosion of coasts as corals and mangroves slow down and absorb wave energy

Conclusion: Environmental health is integral to economic health

Long term perspective needed for sustainability

Level 1 (0-3 marks)

- Listing of how mangroves or coral reefs cause impacts to economy or environment but no detailed description
- No locations or examples given
- Very general answer with not much development
- No supported reasons

Level 2 (4-6 marks)

- Detailed explanations of how mangroves OR coral reefs cause negative impacts to economy AND/ OR environment
- Locations of countries and few examples given
- Answer written in essay form but with poor organization and are not in proper paragraphs

Level 3 (7-8 marks)

- Detailed explanations of how mangroves AND coral reefs cause negative impacts to economy AND environment
- Specific and detailed location of countries and many examples given
- Clear statements of which impacts are more devastating
- Answer written in essay form, with good organization in paragraphs
- Well- balanced conclusion

- 3 (a) Study the 1: 25 000 map extract of Tamarin (Mauritius). Using map evidence, explain why area bounded by Northings 81 to 91 and eastings 82 to 84 is suitable for tourism? [5]

- There is a long stretch of public beach along the coast from Northing 87 to 91, including the river mouth area of River du Rempart, thus enabling beach-related recreational activities and businesses to develop.
- Hotels (grid square 8288 and 8387) provide accommodation for tourists
- Salt pans (8384 & 8485), Martello Tower (825827), coral reefs, Tamarin mountain, sugar and other plantations - attractions for tourists
- Area is served by Main roads and the jetties in the southern part facilitate access.
- The town of Tamarin provides services and facilities like health centre (837818), dispensary and post office (842865)

- (b) Tables 4 and 5 show some tourism statistics for the country of New Zealand.

Table 4

Overseas Visitor arrivals for 2013 - 2016							
	2013	2014	2015	2016	2014	2015	2016
					Annual % change		
Oceania	1,311,872	1,359,120	1,415,588	1,514,080	3.6	4.2	6.9
Asia	528,624	575,200	681,568	814,640	8.8	18.5	19.5
Americas	264,576	285,664	307,024	348,192	8.0	7.5	13.4
Other	88,880	98,048	88,624	89,472	10.3	-9.6	1.0
Total	2,611,377	2,752,257	2,947,901	3,255,463	5.4	7.1	10.4

Table 5

Total Tourism Expenditure by tourists				
Year	Total Tourism Expenditure \$ (million)	Annual percentage change	Gross Domestic Product \$ (million)	International tourism as a % of total exports
2013	26 947	1.3	62 766	15.8
2014	28 039	4.1	67 002	15.4
2015	30 935	10.3	67 514	17.9
2016	34 699	12.2	70 144	20.7

<http://www.tdc.co.tt/index.php>

- (i) Describe and suggest reasons for the trend of visitor arrivals to New Zealand from 2013 to 2016. [4]

From 2013 to 2016, the visitor arrivals to NZ from all regions shown have increased.

Need a home tutor? Visit ^{1m}smiletutor.sg

Largest increase from Asia (8.8% in 2014 to 19.5% in 2016) and Americas (from 8% in 2014 to 13.4% in 2016)
1m

*Other region showed a decline from 10.3% increase in 2014 to 1% increase in 2016. In fact, there was a significant drop in visitor arrivals in 2015 (-9.6%) compared to previous year.

The increase in arrivals from Asia may be because of a rise in disposable income/rise of middle class in countries like China and India (as well as S.American economies), greater awareness of NZ as a tourist destination due to advertising, trade and media. Greater competition among airlines may have led to more attractive airfares, especially for long haul travel from the Americas.

2m

*Although there was a drop in visitor arrivals from 'Other' region (eg, Africa, Middle East) in 2015, the numbers increased again in 2016.

*optional

- (ii) **With reference to Tables 4 and 5, explain how tourism is a boon and a risk to the New Zealand economy.**

Boon:

Tourism brings significant benefits to the NZ economy:

2013 – \$26.9billion; 2016 – increased to \$34.7billion

International tourism accounts for 20.7% of NZ's total exports

This would have led to jobs and stimulated local businesses.

Tourism also lead to more investments into NZ due to greater awareness of business opportunities there.

Bane:

However, the fact that it accounts for 20 % of NZ's exports indicate its reliance on this sector of the economy. This makes NZ vulnerable to fluctuations in visitor arrivals due to economic downturns, outbreak of diseases and other disasters. This would impact NZ negatively, for eg. loss of jobs, closure of businesses.

- (c) **Explain, with the use of examples, how budget airlines have contributed substantially to the growth of tourism.** [4]

Budget airlines has made air transport affordable. They are cheaper than major commercial airlines as they do away with the frills, use smaller and more fuel-efficient aircraft. Most of the them fly to short haul destinations but this too has changed in recent years, with some budget carriers using better planes and travelling up to 7 hours. They sell tickets online , often with good promotional offers, thus attracting more customers.

Budget airlines have enabled more people to travel internationally and more frequently.

It has given travellers the opportunity to go on holidays further away (instead of domestic travel)

It enabled travellers to travel to destinations not covered by commercial airlines, especially in large countries and more remote locations (eg. Bhutan, Shangri-la, Corsica, Crete)

- (d) **"Tourism activities are having a devastating effect on the environment."**

How far do you agree? Use examples to support your answer.

[8]

- When tourism is organised on a large scale such as mass tourism to bring in profit, it will result in environmental destruction. Pollution and litter from tourists have become a major problem. Authorities sometimes fail to implement measures that would probably manage waste left behind by tourist. This can lead to degradation of such areas. For example, tourists often dump plastic bottles, food packaging and old batteries overboard from cruise ships. This causes harbours, marinas as well as the ocean to be polluted. For instance, many islands in the Caribbean have limited space on land to treat waste from ships. As a result, solid and liquid wastes are sometimes dumped into the Caribbean Sea by ships. As such, tourism as an enterprise is destructive in nature.

- Another environmental problem is the destruction of habitats. Popular tourist sites, such as quiet stretches of sandy beaches and scenic villages, can be overwhelmed with visitors during busy times of the year. When too many tourists visit a destination, they may destroy habitat and wildlife. Careless tourists may trample on plants, while others may collect eggs and feathers of birds as souvenirs. These tourists may also make too much noise which can disturb and frighten of animals. For example, Egypt's Red Sea coast has developed into a major diving and snorkelling destination for around 1.2 million visitors annually. Unfortunately, the habitats of coral reefs and exotic fish have been damaged by some swimmers collecting shells or corals as souvenirs, and by hotels and restaurants in the area dumping waste and sewage into the sea. In this way, tourism is a threat to the natural environment

- Tourism also increases the carbon footprint on the environment. These activities may include travelling by planes and tour busses, and electricity consumption by hotels. For example, the carbon footprint of a one-way economy class flight from Singapore to Kuala Lumpur, Malaysia, is 30 kilogrammes of carbon dioxide per passenger. With mass tourism, the environmental impact will be even greater.

- ** Tourism can also destroy the cultural environment of a place through cultural dilution. When tourism becomes the major activity of an area, the identity, culture and values of a can be lost. Commercial activities that cater mainly to tourists, such as food outlets, travel agencies, souvenir shops and hotels, can become the major commercial activities of an area. Older buildings may be converted to host tourist activities. At the same time, new and larger buildings may be constructed for tourism.

- ** These activities may force the locals to relocate their original activities to other places. As a result, the identity of a place may be lost. When this happens, the original environment - atmosphere, appearance and functions of an area change. To meet the demands and expectations of tourists, local cultural festivals and religious rituals are sometimes modified. For example, Rituals may be shortened to fit into the itinerary of tourists. The authenticity and significance of these cultural events may be reduced when they become commercialised. For example, tourists pay a hefty fee to enter the village of the Kayan Lahwi women in

Need a home tutor? Visit smiletutor.sg

Thailand. Due to the entrance fee, some tourists treat the women as exhibits that they are paid for. The tribe loses its cultural identity.

** optional

However, tourism can also be beneficial to the environment:

Conservation and preservation of natural and built environments (coral reefs, rainforests, mountainous areas, cultural & heritage sites). Governments are more willing to conserve & preserve environments in order to attract visitors.

Visitor spending can also provide funds for conservation & preservation of environments.

Greater global awareness of the threats to and appreciation of environments can also lead to more support for NGOs and other organisations that seek to protect the environment.

Level 1 (0 – 3marks)

- **At this level answers will be generalised** or with minimal support if any given at all.
- Reasoning rather weak and expression may be unclear.
- **A basic answer** that has little development.
- **Answers lack examples** or other evidence. Or it is so sketchy that it adds **little to support to the answer.**

Level 2 (4 – 6 marks)

- Disagreement or agreement will be supported by appropriate detail. Or both agreement and disagreement are considered, but support is patchy so that the answer is not full.
- Good reasoning and logic in parts of the answer with **good expression in places.**
- Some examples or other evidence will be presented to support answers in at least one place in the answer.

Level 3 (7 – 8 marks)

- At this level answers will be **comprehensive and supported by sound knowledge.**
- Both agreement and disagreement are considered and well supported.
- Reasoning is clear and logical **with good expression of language.**
- Examples or other evidence to support answers will be **extensive**

SmileTutor.sg

Tourist questionnaire

We are doing a tourism survey as part of our Geography coursework. Please will you answer the following questions?

1. Which continent do you come from?

- | | | |
|----------------------------------|--|--|
| <input type="checkbox"/> Asia | <input type="checkbox"/> Africa | <input type="checkbox"/> Europe |
| <input type="checkbox"/> Oceania | <input type="checkbox"/> North America | <input type="checkbox"/> South America |

2. What are the main physical attractions you are visiting whilst in Chiang Mai?

- | | |
|--|---|
| <input type="checkbox"/> Mae Klang waterfall | <input type="checkbox"/> Doi Inthanon Mountain |
| <input type="checkbox"/> Fang Hot Springs | <input type="checkbox"/> Botanical Gardens |
| <input type="checkbox"/> Elephant camp | <input type="checkbox"/> Orchid and Butterfly farms |
| <input type="checkbox"/> Ob Luang Gorge | |

3. What are the main human attractions you are visiting whilst in Chiang Mai?

- | | |
|---|---|
| <input type="checkbox"/> Hill tribe villages | <input type="checkbox"/> National museum |
| <input type="checkbox"/> Shopping at the night bazaar | <input type="checkbox"/> Buddhist temples |
| <input type="checkbox"/> Bhubing Palace | <input type="checkbox"/> Muang Kung Earthenware village |
| <input type="checkbox"/> Royal pagodas | |

Thank you for your time.

Insert

Fig. 2 for Question 1 (b)

Local people questionnaire

We are doing a tourism survey as part of our Geography coursework. Please will you answer the following questions?

1. Do you live in Chiang Mai?

Yes

No

(Finish interview if 'No')

2. What do you think are the main positive impacts of tourism in Chiang Mai?

Number your first and second choices '1' and '2'.

More jobs and income

Improved standard of living

More modern services

Cleaner environment

Improved infrastructure e.g. airport, roads

Reduction in crime

Greater range of goods in shops

Local people have greater global awareness

3. What do you think are the main negative impacts of tourism in Chiang Mai?

Number your first and second choices '1' and '2'.

Noise pollution

Air pollution

Traffic congestion

Increase in crime

Decline of traditional culture and way of life

Increase in litter

Increase in cost of living

Destruction of natural environment for hotels, shops etc.

4. Overall do you think tourism has a positive or negative impact in Chiang Mai?

Positive

Negative

Thank you for your time.

Insert

Table 3 for Question 1(c)

Answers to Questions 2, 3 & 4 of local people questionnaire

Q2 Positive Impacts of tourism	First choice	Second choice	Total score using formula
More jobs and income	27	15	69
Improved standard of living	7	12	26
More modern services	2	6	10
Cleaner environment	3	1	7
Improved infrastructure	8	6	22
Reduction in crime	1	12	14
Greater range of goods in shops	6	6	18
Local people have greater global awareness	7	3	17
Total	61	61	

Q3 Negative Impacts of tourism	First choice	Second choice	Total score using formula
Noise pollution	4	7	15
Air pollution	16	10	
Traffic congestion	17	14	48
Increase in crime	3	4	10
Decline of traditional culture and way of life	7	5	19
Increase in litter	3	7	13
Increase in cost of living	4	9	17
Destruction of natural environment	7	5	19
Total	61	61	

Q4 Overall impact of tourism	Answers
Positive	53
Negative	8

Insert

Fig. 1 for Question 1(a).

SmileTutor.sg



ST JOSEPH'S INSTITUTION

**PRELIMINARY EXAMINATION 2017
(SECONDARY 4)**

GEOGRAPHY

2236/02

Paper 2

29 August 2017

Additional Materials Insert
 Writing Paper

1 hr 30 minutes
(8.00am – 9.30am)

READ THESE INSTRUCTIONS FIRST

Write your Class, index number and name on all the work you hand in.
Write in dark blue or black pen on both sides of the paper.
Do not use paper clips, highlighters, glue or correction fluid.

Section A

Answer **one** question.

Section B

Answer **one** question.

Write all answers on the writing paper provided.
Candidates are encouraged to support their answers with the use of relevant examples.
Sketch maps and diagrams should be drawn whenever they serve to illustrate an answer.

Insert contains
Fig. 5A and Fig. 5B for Question 2 (b)
Fig. 9 & 10 for Question 4 (a)
Fig. 11 for Question 4 (b)

At the end of the examination, fasten all your work securely together.
The number of marks is given in brackets [] at the end of each question or part question.

This document consists of **11** printed pages, including the Cover Page and Insert.

[Turn over]

Section A

Answer one question from this section.

- 1 (a) (i) Fig. 1 below shows the relationship between pressure and altitude.

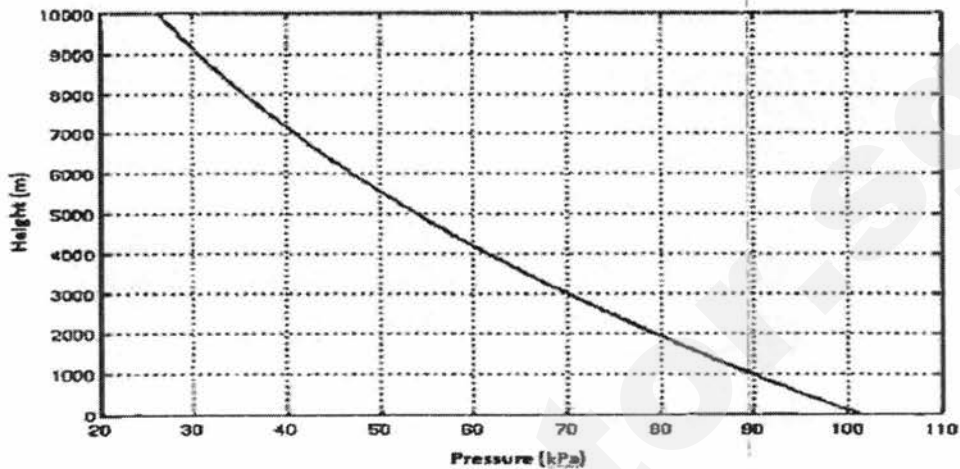

<https://physics.stackexchange.com>

Fig. 1

Describe and explain the relationship between altitude and pressure [3]

Relationship : The higher the altitude, the lower the pressure. For eg. pressure at sea level (0m) is about 102kPa where at 4000m, the pressure is 60kPa.

Air is denser at lower altitude because it tends to be more compressed where the larger overlying mass exerts greater gravitational force.

- (ii) The simplified isobar map for East Asia and Australia in December is shown in Fig.2 below.

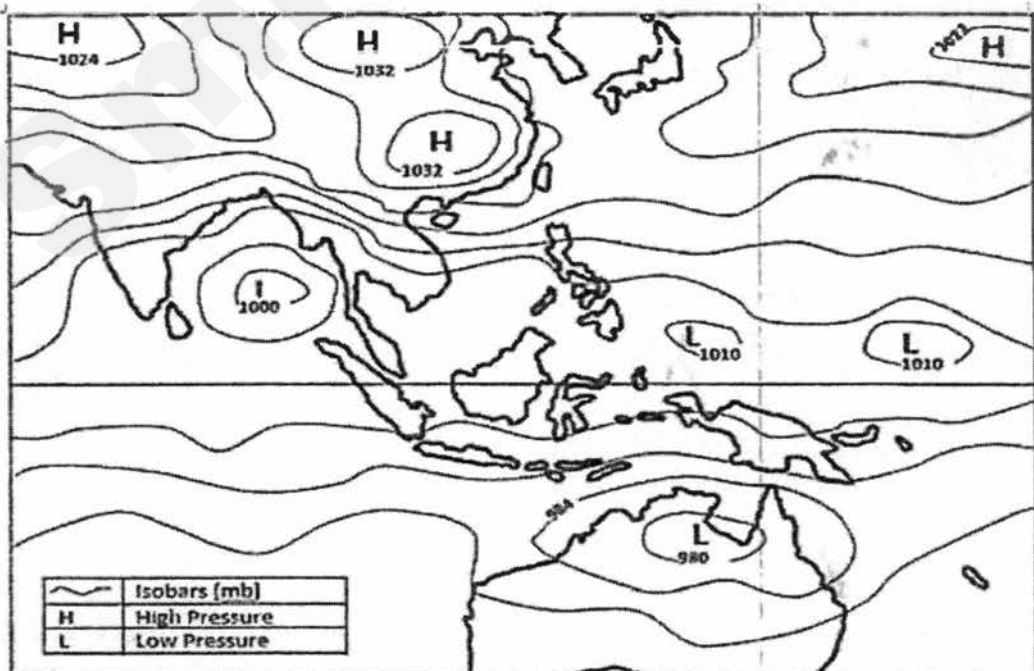

Adapted: <http://www.vagaries.in/2012>

Fig. 2

Need a home tutor? Visit smiletutor.sg

Based on the information in Fig. 2, account for the high and low pressure cells in the region shown and the likely wind pattern that will form.

In December, the northern hemisphere is getting cooler as winter is approaching and the southern hemisphere is approaching summer. With cooler temperatures at higher latitudes (eg. over Mongolia, Korea and China), the cold air sinks thus creating high pressure cells of about 1026mb.

At the equator, the temperatures are still high. The warm air rises, creating cells of low pressure of about 1010mb. The high temperatures in the southern hemisphere, especially over the continent of Australia will also experience similar conditions of low pressure.

A pressure gradient is thus set up between the high pressure cells at higher latitudes and the low pressure cells over at the equator and the southern hemisphere.

Winds will thus blow out from the high pressure cells over China and Mongolia as the North West monsoon and due to the Coriolis effect, blow towards Peninsula Malaysia as the North East monsoon in the coming months. Australia will be experiencing the NW monsoon winds.

(b) Explain how the presence of cloud cover can affect the daily temperature range. [4]

During the day, clouds (made up of visible water droplets or ice crystals) reflect a large portion of the sun's short wave energy back to space and only some of this energy enters the earth's atmosphere. This keeps the earth's surface cool. **At the same time**, clouds also absorb radiated heat (long wave energy) from the earth's surface.

During the night, clouds absorb more of the heat (long wave energy) that is radiated from the earth's surface and prevent it from escaping into space. The air near the earth's surface is thus kept warm at night. The diurnal temperature range is therefore small.

(c) Study Fig. 3 which shows the path of a tropical storm.

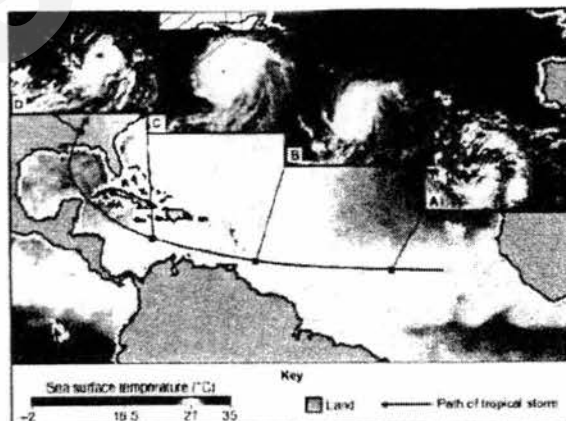

Source: © Commonwealth of Australia (2008), Bureau of Meteorology

Fig. 3

With the help of Fig. 3, explain the development of the tropical storm from A to D. Tropical storms are weather systems that develop over warm oceans in the tropics. They range in diameters from 150 km to >1500km, with sustained wind speeds of 120kmph or more. 1m

At the early stage (A), sea surface temperatures rise (>25 degrees Celsius), creating large volumes of clouds as warm moist air expands and rises. A low pressure cell begins to form. 1m

As this continues (B), the rising warm air condenses into large clouds, releasing latent heat, thus continuing to warm the air, making it expand and rise further. This reduces the air pressure over the ocean surface, creating and sustaining an area of low pressure. A steep pressure gradient develops, drawing in strong winds into this area of low pressure which spirals inwards and upwards at high speeds. The spiralling is created by the Coriolis effect. [5]

1m

A well-developed tropical storm, as seen in C, where the warm rising air cools and sinks. The descending dry air creates an environment (in the centre of the cyclone characterised by calmness and absence of clouds. Surrounding this centre, called the 'eye' are the huge towering thunderstorm clouds, (seen as curved bands of clouds surrounding the eyewall). In addition to strong winds, heavy rainfall will occur. [The winds will also whip up strong waves surging onto the coastal areas (storm surge).]

1m

When the cyclone hits land (D), it brings heavy downpours and high speed winds. The is followed by a period of relative calm as the 'eye' passes the area and then followed by heavy rains and strong winds as the rear of the cyclone passes. 1m

As it moves inland, the source of the warm rising air is no longer present and the cyclone gradually dissipates. 1m

- (d) 'National measures are more effective than international agreements in reducing the impact of climate change'.

To what extent do you consider this statement to be true? Use examples to support your answer. [8]

Any one or two of the national strategies should be discussed.

- Singapore Green Plan 2012 : Reduce greenhouse gas emissions by using natural gas as an energy source
- Green Mark Scheme: Constructing 'green' buildings
- Plant a tree Programme : Planting more trees and plants
- National Urban Transport Policy in India: public transport
- Energy labelling Programme: reducing energy consumption

Description of strategy	Successes	Limitations
<p>Launched by the Ministry of the Environment in 2002, the Plan aims to generate 60 per cent of Singapore's energy needs using natural gas by 2012. Natural gas is a cleaner form of energy in comparison to coal because it does not produce smoke.</p>	<p>As early as 2010, about 79 per cent of Singapore's electricity was being generated from natural gas. This exceeded the Ministry of Environment's target ahead of schedule.</p>	<p>Natural gas requires complex treatment plants to process and pipelines to transport. These pipelines have high maintenance costs because they need to be laid underground and have to be checked regularly for leakage.</p>
<p>Launched by the Building Construction Authority (BCA) in 2005, the scheme allows buildings to be evaluated and certified according to how energy-efficient and environmentally friendly they are. The scheme aims to encourage more new 'green' buildings, which are more energy-efficient. Buildings which are more energy-efficient use less energy to provide the same service. An example is buildings that run partly on solar energy.</p>	<p>Existing 'green' buildings, such as Plaza by the Park, Standard Chartered @ Changi and the National Library Building, have reported energy savings of 15 per cent to 35 per cent compared to conventional buildings. This cuts down greenhouse gas emissions by reducing the use of fossil fuel to generate electricity.</p>	<p>Construction companies and developers in Singapore tend to be conservative about adopting new ideas and materials to build 'green' buildings. 'Green' buildings are built using processes that are environmentally friendly and resource-efficient.</p> <p>'Green' buildings may cost more to build because 'green' materials may be more expensive. 'Green materials' are products such as bamboo or recycled metal that are non-toxic, reuseable, renewable, or recyclable.</p>
<p>Started in 1971 as Tree Planting Day, the Plant-A-Tree Programme by the Garden City Fund and Singapore Environment Council aims to maintain Singapore's status as a Garden City by planting trees. Residents are encouraged to donate money to buy a tree or take part in tree planting events that take place monthly throughout Singapore.</p>	<p>The programme has contributed to an estimated 60,000 trees planted yearly throughout Singapore by the National Parks Board (NParks). Trees are the green lungs of the environment as they remove carbon dioxide from the atmosphere.</p>	<p>Trees take many years to mature, so the positive effects of tree planting will take time to materialise. Even relatively fast-growing trees such as angsanas, raintrees and yellow flames that were planted by NParks took 25 years to reach their full height.</p>

International strategies (1 or 2 to be discussed)

Kyoto Protocol

Copenhagen Conference

• Singapore Green Plan 2012

Kyoyo protocol

Successes

Many countries such as Austria, Finland, Greece met or exceeded targets (5%) set by Kyoto Protocol as there was constant monitoring and reporting by

countries for self and peer assessment.

Encouraged sustainable development.

Developed countries are encouraged to work with developing countries in carbon-reducing projects e.g. installing energy efficient infrastructure (Clean Development Mechanism — CDM) which gave Certified Emission Reduction (CER) credits to countries that helped.

Each credit is = 1 tonne of CO₂ which they are allowed to release.

Limitations

Not all countries are able to meet their goals and not all countries have the same emission targets.

Denmark, Sweden and the United Kingdom did not achieve their targets

KP does not make it compulsory for countries with low GHG emissions to provide support to other countries.

Many countries did not sign the Kyoto Protocol and continue to contribute to global emissions.

A large portion of the increase in global emissions (35%) came from China, India and the United States of America

Copenhagen Conference

Successes

Allow countries to discuss measures to deal with climate Change effectively, including improvements to Clean Development Mechanism (CDM).

International agreement to **keep increase global temperature below 2°C**

Developed countries pledged to:

Reduce **greenhouse** gas emissions by 2020.

Provide **US\$30 billion** for developing countries to fight climate change

Limitations

Targets set to reduce GHG are insufficient to keep increase of global temperature to within 2°C

Lack for concrete plans on how to reduce greenhouse gases

Copenhagen Accord (Agreement) was not adopted by **all countries**.

- The Accord was a guideline and no countries will be **binded/punished** if they do not fulfill their pledges.

Conclusion:

International organisations share knowledge/info/funds; encourage & persuade; set broad goals

BUT practical policies and detailed action best carried out at National level after translating goals into plans

Level 1

Only national or international measures discussed

Answers are brief and not elaborated

No successes and limitations given

No examples given

Level 2

Both national and international measures discussed

Answers are well-elaborated but not very detailed.

Both successes and limitations each for each measure and agreement

Need a home tutor? Visit smiletutor.sg

Some examples given
There is an attempt t

Level 3

Both national and international measures discussed

Answers are well-elaborated.

Both successes and limitations each for each measure and agreement

Multiple examples given

Balance in answer and evaluation is clear, organised and cohesive.

Good links to the question is apparent

- 2 (a) (i) Study Fig. 4A which shows the location of Moscow and Singapore and Fig. 4B which shows the climographs of these 2 cities. [4]

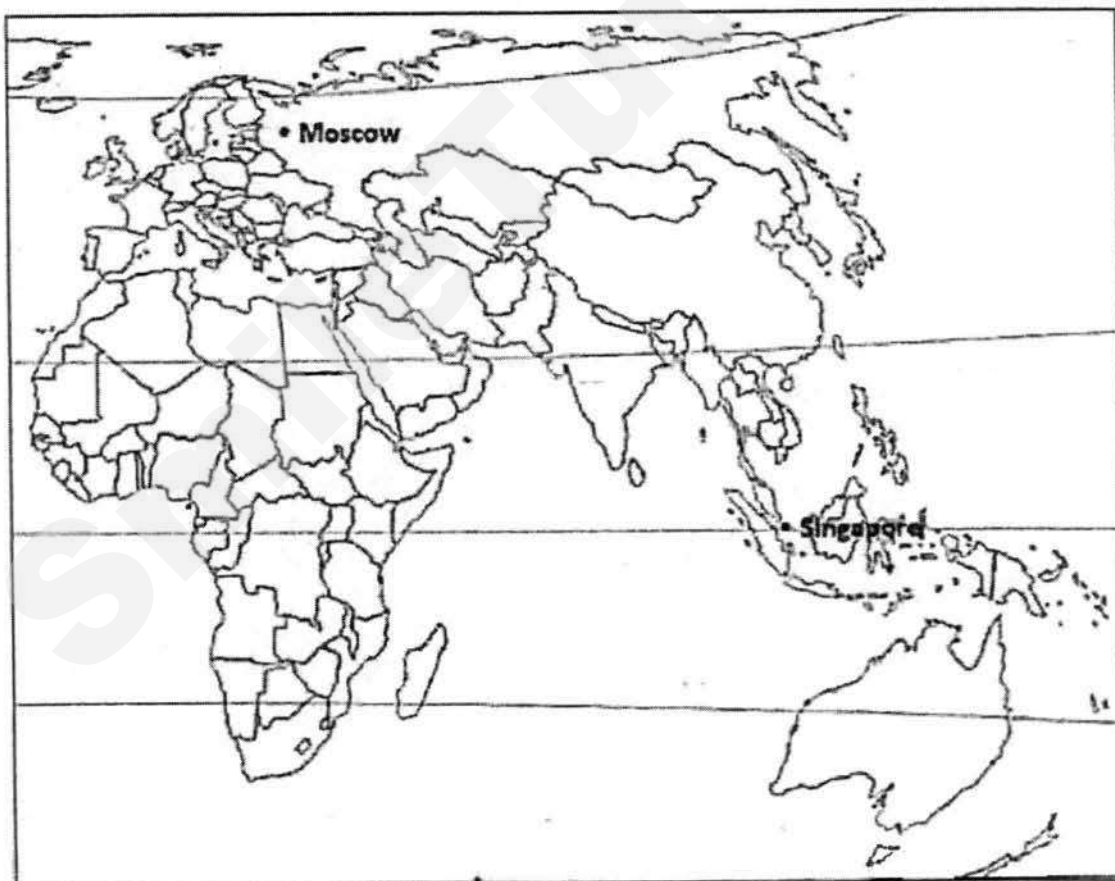
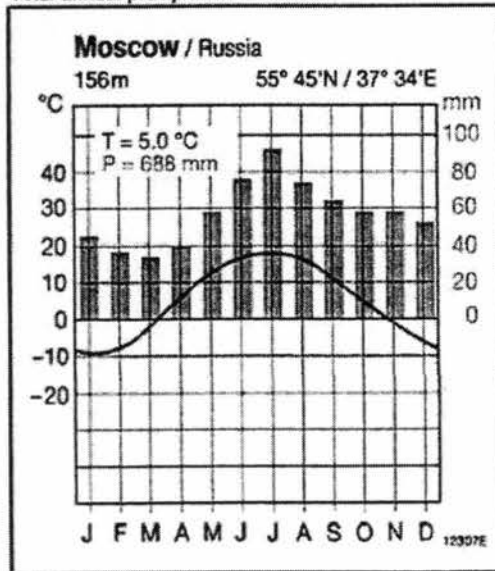

Fig. 4A

Moscow: 55°N 37°E

Mean annual temperature = 5.0°C

Total annual precipitation = 688mm



Singapore: 1.3°N 103°E

Mean annual temperature = 26.9°C

Total annual precipitation = 2275mm

<https://en.climate-data.org>

Fig. 4B

- (i) With reference to Fig. 4A and Fig. 4B, compare the rainfall and temperature of Moscow and Singapore. [

	Moscow	Singapore
Mean annual temperature	5C – low	27C – hot / high
Range of temp	large annual range of -28C	Small/narrow annual range of 3C
Max and Min temp	Max – 19C Min - -10C	Max – 27C Min – 23C
Seasonal temp	Warm summers, cold winters	Hot throughout the year
Total rainfall	moderate of 688mm/yr.	Very high >2000mm/yr.
Rainfall variations	Summer rain, snow in winter	Rain throughout the year, evenly distributed with slightly higher rainfall during end of the yr.

1m – Mean annual temp & season

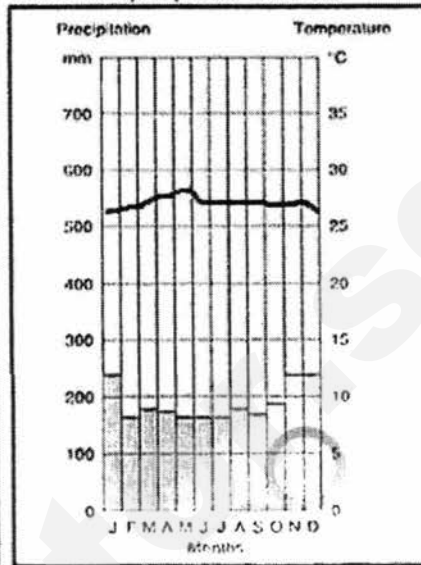
1m – Temperature range; Max & min

1m - Rainfall total

1m – Rainfall distribution

- (ii) Account for the temperatures of Moscow and Singapore. [4]

Moscow is in higher latitudes whereas Singapore is closer to the equator, therefore:

Moscow has a lower solar angle. The curvature of the earth surface diffuses the sun's rays and heat spread out over a larger area

Whereas Singapore - sun's rays strike at a higher angle and hence, solar energy is concentrated on a smaller area. Thus experience a higher average temperature.

Moscow is located further inland (**Continental effect**). In warmer months (summer), the land heats up faster than places nearer the sea (as water absorbs heat slower). Inland areas like Moscow therefore has high summer temperatures. In winter, the land loses heat faster than water, hence temperatures in Moscow are much lower than places nearer the sea. The temperature range of Moscow is therefore large whereas Singapore is an island and does not have the effect of continentality.

- (b) Study Fig. 5A which shows a volcanic hazard risk map for an area in California in the United States of America (USA) and Fig. 5B which is a write-up on the Lassen Volcanic National Park.

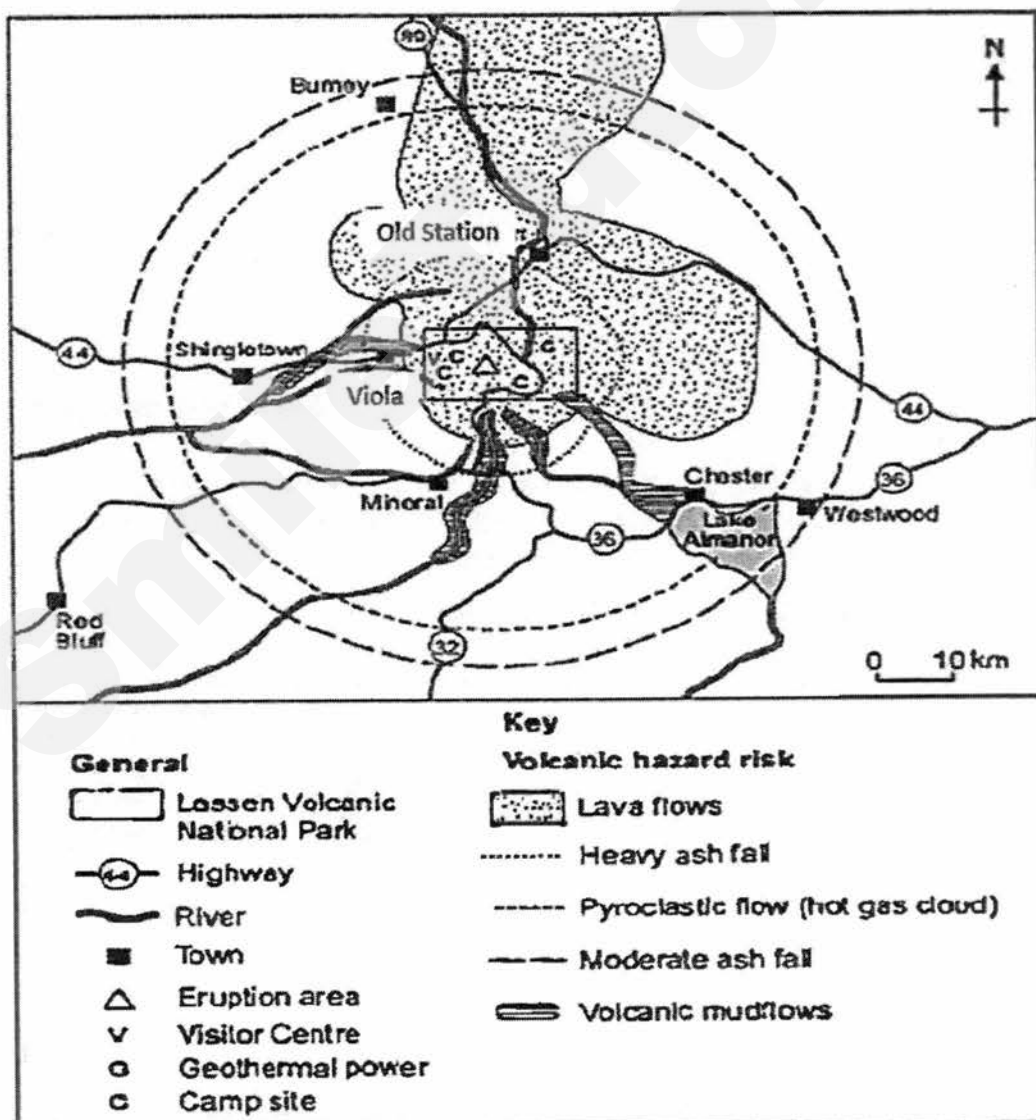

Fig. 5A

The source of heat for volcanism in the Lassen area is subduction off the Northern California coast of the Gorda Plate diving below the North American Plate. The area surrounding Lassen Peak is still active with boiling mud pots, stinking fumaroles, and churning hot springs. Starting in May 1914 and lasting until 1921, a series of major explosive eruptions occurred on Lassen. These events created a new crater, and released lava and a great deal of ash.

Fig. 5B

Source: US Geological Survey, USA

- (i) Based on the information in Fig. 5A and Fig.5B, what type of volcano will likely form in the area shown? Explain your answer. [4]

Possibly Stratovolcano/Composite volcano. Or Cinder cone on top of lava field.

Subduction of Gorda plate below North American plate. Subduction zones usually result in stratovolcanoes

These are formed from successive major/ violent eruptions of lava and pyroclasts.

Pyroclasts refer to ash, rock fragments and volcanic bombs ejected during a volcanic eruption.

After an initial eruption of pyroclasts, the subsequent eruption ejects lava which covers the pyroclasts and prevents it from being eroded away. When pyroclasts mix with super-heated gases ejected during a volcanic eruption, it results in pyroclastic flows. Pyroclasts may also mix with water from melted ice or lakes to result in lahars which are fast flowing mudflows, covering large areas.

Caldera formed due to explosive nature of the eruptions.

The area shown in the diagram shows lava flows, ash fall, pyroclastic flow and mudflow.

Successive eruptions over time may build a high and steep volcano on one side or cinder cones on top of a ash and lava field.

- (ii) With reference to Fig. 5A and Fig.5B and studies you have made, describe the type and level of risk for towns like Westwood and Bumey as compared to Old Station and Viola. [5]

Distance from eruption area (lesser risk with distance from eruption)

Viola – 12km

Old Station - 18km

Westwood – 45km

Bumey

–

35km

1m

Heavy ash fall and pyroclastic flow – Viola and Old Station within radius whereas Bumey and Westwood is further away, affected by moderate ash fall.

1m

Lava flows towards the north – Old Station is in its path. Although Bumey could also have been affected. 1m

Old Station and Viola are near rivers. Viola affected by volcanic mudflows. Westwood is blocked by Lake Almanor from the effect of volcanic mudflow. 1m

Therefore, Old Station and Viola face higher level of risk than Westwood and Bumey.

*float 1m

- (c) "Since earthquakes are hard to predict, it is better to invest in response measures than preparedness measures."

To what extent do you consider this statement to be true? Use examples to support your answer. [8]

Response Measures include: (1-2 of the following)

Short-term responses

*Search and rescue. Survivors have been found even after a few days. Limited time of 72 hours for survival of trapped victims. Can be hampered by lack of equipment and skilled personnel.

*Emergency food, water and medical supplies. These have helped survivors to continue with their lives for the time being. Limited by the amount sent and the availability and accessibility to such supplies.

Long term responses

*Rebuilding of infrastructure after the earthquake. Stricter building codes and restoration of infrastructure. Limitation include protection against tsunamis may not be done.

*Provision of healthcare including long term counselling. However, restoring the resilience of people after an earthquake can be challenging as they still lack basic services and facilities for a normal life.

Preparedness Measures include. (1-2 of the following)

Land use regulations

Land use regulations are rules that restrict developments in certain areas that have been deemed to be at greater risk to damage from earthquakes.

For example in California, all new building developments are not build across fault lines or areas at risk of liquefaction.

Also along the coasts of Japan and North America, construction of new buildings are not permitted on low lying areas in case of tsunamis.

This is to minimise the damage to property and danger to human lives.

However these measures may be costly as many of these areas may already be populated and governments would have to compensate those already living there.

Also, private owners may be reluctant to move as they feel that another earthquake may not occur in their lifetime.

Building Design

Building with steel and reinforced concrete make building more able to withstand earthquakes. Including damping devices in the building design allow seismic energy to be absorbed in an earthquake. Also, constructing buildings with a wide

and heavy base decreases the likelihood of these building collapsing.

All these are incorporated into Taipei 101, a building in Taiwan.

Effective building design can reduce the likelihood of building collapse and minimize the damage caused by earthquakes.

However, such buildings can be costly to build and maintain. It may also be costly to convert existing buildings.

Infrastructure Development

Infrastructure needs to be developed with advanced engineering to withstand the shocks associated with earthquakes.

Roads, bridges and dams can be built to withstand earthquake shocks or made more to be more easily repaired.

Buildings can be fitted trip switches that ensure all electrical points are switched off in an earthquake to prevent fires from breaking out.

Underground water tanks are built as emergency reservoirs to fight fires after an earthquake.

Past earthquake events have demonstrated that using this technology, fewer lives are lost, faster rescue and evacuations and less money spend on recovery for the affected areas.

Developing infrastructure to withstand earthquakes is more costly and in some places remains untested.

Emergency Drills

Emergency drills are a form of preparedness measure where people practice the steps to take when an earthquake occurs

Every year on September 1st, Japan conducts emergency drills to simulate the occurrence of an earthquake of high magnitude. This is to prepare the people mentally on how to react to a disaster

Emergency drills create awareness and reduces panic in people when an earthquake strikes by ensuring that people know what to do in the event of an emergency.

However these drills are based on the scale and magnitude of past events and therefore emergency scenario might not be realistic if a more powerful earthquake strikes the area

Use of Technology

Technological devices such as monitoring and warning systems allow scientist to warn people of imminent earthquakes so that they can take appropriate action.

Advanced technology such as seismic risk map, earthquake sensor and tsunami monitoring systems help to detect earthquakes earlier.

If scientists determine that an earthquake or tsunami is imminent, people can be evacuated from high-risk areas, emergency services can be placed on high alert to reduce the number of casualties.

However, these systems are costly to install and use. There is a possibility of false alarms as these systems are subjected to interference by lightning or storm waves. There is also very little time for response, as the systems do not give enough time for evacuations to take place.

Conclusion: People respond to earthquakes by trying to prepare for them and putting in place preparedness measures to mitigate the impacts. However, even

the best preparation, which can be costly, may not be adequate or be sufficient to deal with the unexpected. When earthquakes do occur, people have to deal with the impacts with short and long term responses.

Level 1 (1-3 marks)

Answers will be generalized or with minimal support if any given at all. Reasoning rather weak and expression may be unclear. A basic answer that has little development. Answers lack examples or other evidence, or it is so sketchy that it adds little support to the answer.

Level 2 (4-6 marks)

Response or preparedness measures will be supported by appropriate detail. Or, both types of measures are considered, but support is patchy so that the answer is not full. Good reasoning and logic in parts of the answer with good expression in places. Some examples or other evidence will be presented to support answers in at least one place in the answer.

Level 3 (7-8 marks)

Answers will be comprehensive and supported by sound knowledge. Both types of measures are considered and well supported. Reasoning is clear and logical with good expression of language. Examples or other evidence to support answers will be extensive. Conclusion as to which type of measure is better will be based on a criterion (eg cost considerations or effectiveness in reducing losses). Conclusion can also be based on the complementarity of both types of measures as both are necessary to deal with different circumstances.

Section B

Answer one question from this section.

3. (a) (i) Fig. 6 shows the amount of meat and seafood imported into Singapore from 2004 to 2013.

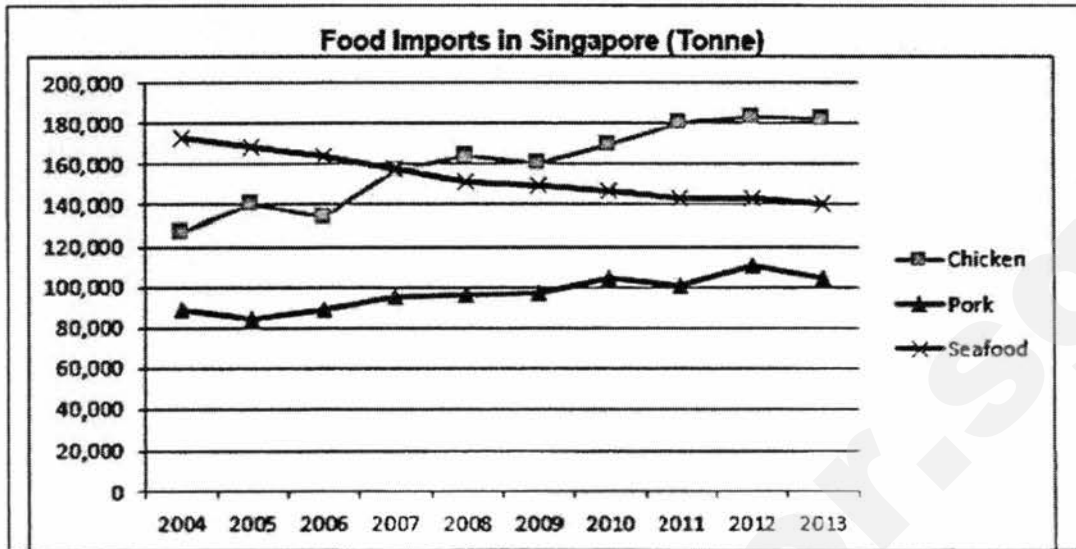

Source: Agri-Food and Veterinary Authority of Singapore
Fig. 6

With reference to Fig. 6, compare and account for the trends in demand for chicken, pork and seafood [5]

Reserve 1m for trend.

Reserve 1m for data to support each trend.

1m for each of the following points:

- Between 2004 and 2013 both pork and chicken show a general increase a food imports in Singapore while seafood shows a general decline.
 - Chicken increased by about 55,000 tonnes while pork increased by about 15,000 tonnes.
 - on the other hand, seafood has decreased by about 35,000 tonnes.
 - This have be because local fish farms have increased production. thus leading to lower imports.
- **Chicken has** a steeper and greater rate of increase than pork.
- **Chicken is** considered to be a healthier option than pork and can be consumed by all cultures/religions whereas pork is not eaten by Muslims.
- While seafood imports were higher than chicken between 2004 and 2007, it was less than amount of chicken imported after 2007.
- Pork is the lowest amount of meat imported as compared to chicken and seafood from 2004 to 2013.

(ii) The targets for local production of 3 key food items are shown in Fig. 7 below.

Key food items	2020 Local production targets	2014 production
Hen shell eggs	30%	25%

Leafy vegetables	10%	12%
Fish	15%	8%

Source: Agri-Food and Veterinary Authority of Singapore
Fig. 7

What are some of the challenges in meeting the production targets and suggest possible strategies that can be used to overcome such challenges? [6]

Challenges:

Lack of land space for large scale cultivation of **vegetables and chicken/egg farms**; limited coastal areas for setting up aquaculture farms as Singapore has narrow territorial waters

Lack of interest in investments in agriculture especially from local businesses; farming in S'pore is high **-tech** and requires substantial capital outlay

Shortage of manpower; **few people keen** on working in this sector

Possible strategies:

Improved mechanisation – use of advanced machinery to perform **tasks which they would otherwise** have to do manually.

Use of computers in Singapore's high-tech farms **allows fewer workers** needed to grow crops on the farms. Use of other high-tech farming techniques – vertical farming to save space; use of **chemical solutions** in aeroponics and hydroponics etc.

Use of biotechnology – use of GM crops, which have a higher yield than non-GM crops.

Social strategies – encourage locals to support **the local farmers** by purchasing locally produced food through **advertising and campaigns**. This will help to keep the **local farmers in business** through ensuring demand for their produce. **Encourage and support** community and urban farming.

Government policies that will support and encourage local agricultural production that will **attract investments and long term sustainability** of such enterprises. This can include **low cost land rent, technical assistance and tax incentives**.

- (b) Fig.8 shows the amount of farm land used by countries for the production of genetically modified crops in 2000 and 2006

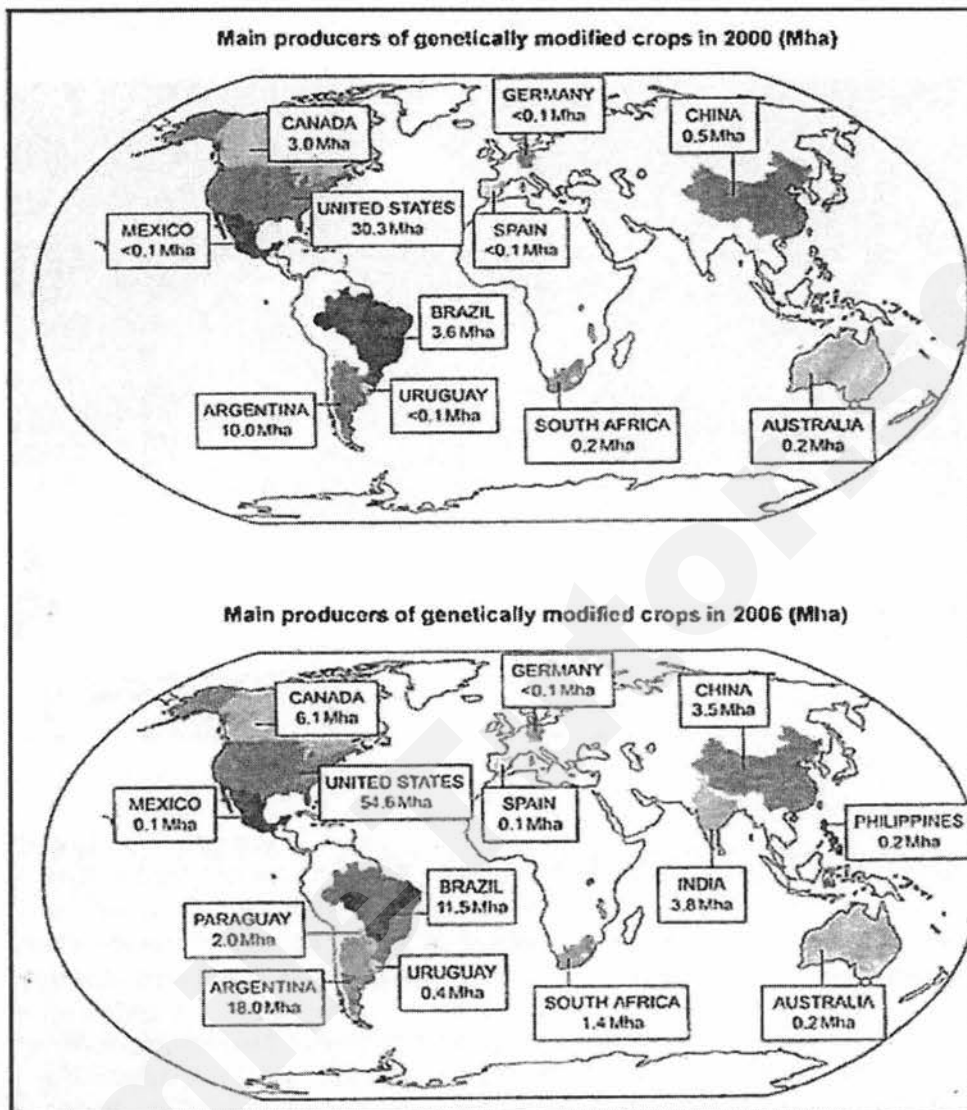

<http://www.economist.com/blogs/dailychart/2011>

Mha = million hectares

- (i) With reference to Fig. 8, describe the changes to the production and location of genetically modified crops and the area they cover between 2000 and 2006. [4]

- GM food is mainly produced in the continents of North and South America and parts of Asia. There is little GM food produced in the continents of Europe and Africa. 1m
- In 2000, most of the main producers are the developed countries in North America e.g. the United States (30.3Mha)USA, Canada (3.0Mha), Australia while in 2006, there are many new new main producers are from the less developing countries in Asia and South America 1m
- The number of main producers of genetically modified food has increased from 11 in 2000 to 14 in 2006 New producers include

countries such as , India (3.8Mha), Paraguay (2.0Mha) and the Philippines.

1m

- There is an overall increase in the area used in producing GM food across the world, e.g. In the United States, the area used for growing GM crops increased from 30.3Mha in 2000 to 54.6Mha in 2006, but the continents of Europe and Africa remain largely unaffected by GM food production.
- All countries saw an increase in GM food production except for Germany and Australia.

1m

- (ii) Suggest reasons why countries like India, Paraguay and Philippines are cultivating GM crops. [3]

Reasons for cultivating GM crops:

1. Increased demand due to increasing population and export to other countries
2. **Need to ensure better crop survival and yield** through crops that can produce more, tolerate pests and diseases
3. **Introduction of GM crops technology into these countries** through Government agricultural policies and investments in agribusinesses (globalisation)

- (c) "Adopting modern technology in agriculture is more effective in increasing food production than using agricultural strategies."

To what extent do you consider this statement true? Use examples to support your answer. [8]

Agricultural strategies:

Multiple cropping and crop rotation

Advantages – nitrogen released by leguminous crops act as fertiliser for other crops; growing a variety of crops minimises **problem of pests**; reduces dependence on only one crop due to pests, price **fluctuations**

Water and soil conservation

No-till farming where weeds are not removed and no digging of soil. Plant materials from previous season kept to improve quality of soil. This protects soil from erosion.

Leasing farmland to other countries

Land scarce countries lease farmland from other countries for agriculture.

Eg. South Korea leased >3million acres from Madagascar

Countries with land but cannot produce enough food can lease out farmland to generate income

Modern technology strategies:

Storage – refrigerated warehouse/trucks; silos
 Cut spoilage and loss of crops & made food available and accessible eg. Timor Leste
 Limitation of cost

Farming technology - use of HYVs, irrigation, chemical fertilisers and pesticides and machinery (*green revolution)

Biotechnology – GM foods have higher yield, can be grown in previously less suitable areas and are more resistant to weather conditions. But there are still concerns regarding GM crops and GM seeds are out of reach of any farmers in LDCs.

Conclusion:

Modern technology have increased food production tremendously in the last 5 decades. Its effectiveness in improving food production is without question. The potential to harness technology in areas with difficult conditions will benefit many countries. However, there are lingering concerns over the impacts on environment and consumers. Agricultural strategies can complement technology in **providing a more balanced** and environment friendly solution.

Level 1 (1-3 marks)

Answers will ~~be generalized~~ or with minimal support if any given at all. Reasoning rather weak and expression may be unclear. A basic answer that has little development. Answers lack examples or other evidence, or it is so sketchy that it adds little support to the answer.

Level 2 (4-6 marks)

Technological or agricultural strategies will be supported by appropriate detail. Or, both types of strategies are considered, but support is patchy so that the answer is not full. Good reasoning and logic in parts of the answer with good expression in places. Some examples or other evidence will be presented to support answers in at least one place in the answer.

Level 3 (7-8 marks)

Answers will be comprehensive and supported by sound knowledge. Both types of strategies are considered and well supported. Reasoning is clear and logical with good expression of language. Examples or other evidence to support answers will be extensive. Conclusion as to which type of strategy is more effective will be based on a criterion (eg greater output or environment-friendly). Conclusion can also be based on the complementarity of both types of strategies as both are necessary to deal with different circumstances.

4. (a) Study Fig. 9 (Insert) which is a map of Africa showing trends of drought areas in Africa and Fig. 10 which shows countries in Africa facing a food

shortage problem.

(i) Using Fig. 9 and Fig.10, describe and account for the location of areas in Africa facing food shortage issues. [4]

- The African countries facing food shortage are found mainly in sub-Saharan Africa, OR
- found between the Tropic of Cancer and Tropic of Capricorn.

1m for each specific detail, e.g.:

- Whole belt of countries just below northern Africa, + examples of countries (Mauritania, Mali, Niger, Chad, Sudan)
- down the eastern coast and then + examples of countries (Somalia, Kenya, Tanzania, Mozambique)
- Stretching across to west coast, just before southern Africa + examples of countries. (Angola, Zambia, Zimbabwe)

2m
Why?

Many of these countries are at risk of drought.

Drought will lead to poor soil and climatic conditions necessary for crop cultivation. Poor harvests lead to food shortages.

Drought will put these places at risk of desertification where relatively dry area of land becomes increasingly arid, typically losing its bodies of water as well as vegetation and wildlife. Hence sources of food become scarce.

2m

(ii) What are the impacts of food shortages on the people and countries in Africa? [5]

People

- Health – people may suffer from malnutrition in which the body does not get sufficient or balanced of nutrients it needs to maintain healthy tissues and organs. This will lead to death or long-term development problems such as kwashiorkor and rickets.
- Health – People may suffer from starvation which is an extreme form of malnutrition and leading to poor health and death.
- Economic – People are stuck in poverty since children miss out on school days thus reduce educational opportunities, scavenging which leads to ill-health as food may be contaminated.

Countries

- Political – Food shortage may cause social unrest and riots as the people protest or behave violently to show their unhappiness about the situation as they lives are at risk and the government is not managing the problem well.
- Economic – The countries may have little or no progress in terms of development because with the workforce is most often of low productivity due to ill health resulted from food

shortage. Thus, investors will have a lack of confidence in investing their money and resources in these countries, impeding the development of the countries.

- Economic – The government will have a high expenditure on healthcare due to the high demand for health services. This will deny spending on other important aspects of country like education and agriculture which will help the countries to progress.

(b) Study Fig. 11 (Insert 1) which shows the mortality rates of males due to cardiovascular disease (CVD).

(i) Describe the distribution of mortality rates of males due to CVD around the world. [3]

Very High CVD male mortality rates (444- 861 per 100000) occur in regions/countries like Russia, Arab peninsular and parts of Africa (Libya, Sudan, Namibia, Somalia)

High CVD mortality rates (363 -443 per 100000) occur in many countries in Africa, Middle East, Turkey., Indian subcontinent and S.E. Asia.

Lower rates of 120 -238 per 100000 occur in North America (USA, Canada), western S America (Colombia, Ecuador, Peru, Chile), western Europe and Australia

(ii) Suggest how social and economic factors could be reasons for the occurrence of CVD in these countries. [5]

Cardio-vascular disease is a degenerative **disease where affected tissues (heart, blood vessels and affected organs) deteriorate over time.**

Social factors :

Diet – high consumption of meat, fats and sugars, common in DCs

Lifestyle – low levels of physical activity/sedentary; high levels of stress – typical of DCs 1m

**So it is puzzling as to why high rates of CVD male death rates occur mainly in LDCs and not DCs 1m

Possible reason – As LDCs improve economically and due to globalisation, their diet and lifestyle choices have begun to be similar to DCs. 1m

Economic factors:

Poverty and affluence which influences access to healthcare.

DCs have higher investments in healthcare, with more and better health facilities and services.

Hence, lower CVD male mortality rates occur in DCs. 2m

(c) "The efforts of governments in managing the spread of diseases cannot succeed without the cooperation of individuals and communities."

To what extent do you consider this statement true? Use examples to

support your answer.

[8]

Example of content

Precautionary- measures take before the outbreak of the disease to reduce occurrence.

Describe	Explanation and Example	Successes	Limitation
<p>Vaccination Increases body immunity to certain diseases</p>	<p>Vaccination helps to reduces a person's chance of getting infected and spreading the disease.</p> <p>In 2009, Singapore began providing vaccinations for its population against the H1N1 influenza virus before it emerged in the country. Clinics island-wide were made H1N1-ready</p>	<p>When the outbreak occurred, most of the cases were mild and death rates were low.</p>	<p>Individuals can choose not to take the vaccinations.</p> <p>Vaccinations also took 2 weeks to take working. Infection could take place during these two weeks.</p>
<p>Community Education</p>	<p>The NEA has a five-pronged approach to vector control: 5 steps to Mizzie wipe out. It was launched on 28 April 2013.</p> <p>There is a "Colour Code Alert System", which indicates the seriousness of the dengue situation through colour-coded banners. The colours indicate the corresponding preventive measures to take.</p>	<p>The WHO cited Singapore as a role model.</p> <p>The number of cases with more serious dengue fever has decreased in recent years since the 2005 dengue fever outbreak.</p>	<p>Most people are unaware or complacent about Aedes mosquitoes breeding at their place of residence. This posed difficulties in preventing the breeding of the mosquitoes.</p> <p>Due to climate change, mosquitoes breed faster at higher temperatures.</p> <p>More people had been infected with Den-1, a new dominant virus. It can spread faster and majority of the population has no immunity against this new virus.</p>

Mitigation Measures- measures taken after the outbreak of the disease. This measures will reduce the impact of the diseases

Describe	Explanation and Example	Successes	Limitation
Control measures	<p>Detecting and isolating infected people in a dedicated hospital. A dedicated private ambulance service was used to transport people suspected to be infected.</p> <p>Potential patients of the diseases was home- quarantined by law</p> <p>Health screening became mandatory at hospitals, schools and other public areas.</p>	<p>Governmental intervention was prompt and open. This reduced the chances of SARS being spread to more of the population.</p>	<p>Some patients displayed symptoms not commonly associated with SARS. Some patients who did not show any signs of SARS until much later.</p> <p><u>Some individuals deliberately broke quarantine rules;</u> thereby infecting others</p>

Communities can work together to control diseases by:

Introducing possible control strategies

Ground-level outreach to educate, persuade and monitor strategies. People are **more** receptive to advice/info from fellow citizens

Train and assist government depts.

Provide support to those undergoing treatment at community/local level

Conclusion:

Any measure/strategy at controlling or mitigating diseases can only **succeed with cooperation** from individuals.

Pathogens and carriers of diseases are cannot be **eradicated entirely and easily transmitted.**

Communities' efforts in supporting the strategies have a **better chance to succeed through** shared responsibility and efforts.

Level 1: 0-3 marks

- At this level answers will be generalized or with minimal support if any stand were given at all.
- Reasoning rather weak and expression may be unclear.
- A basic answer that has little development.
- There may be no or little attempt at indicating effectiveness of the government measures. This means that only government measures are considered.
- Maximum 3 marks if answers lack examples

Level 2: 4-6 marks

- At this level answers will contain some appropriate detail.
- The content will lack balance and some relevant detail. Government, individual and community efforts are considered but support is patchy so that the answer is not full.

- Assessment may be given but may be general in nature.
- A country will be named in the answer.

Level 3: 7-8 marks

- At this level answers will be comprehensive and supported by sound knowledge.
- There will be assessment made of the role of government, individuals and communities in managing infectious diseases.
- Located examples are necessary.

Insert

Fig.9 and Fig. 10 for Question 4 (a)

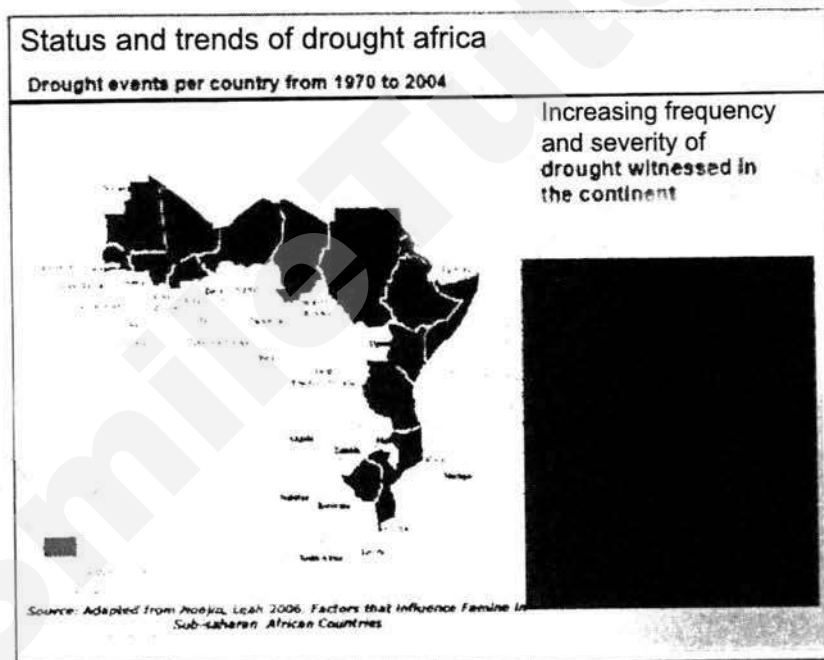

Fig. 9

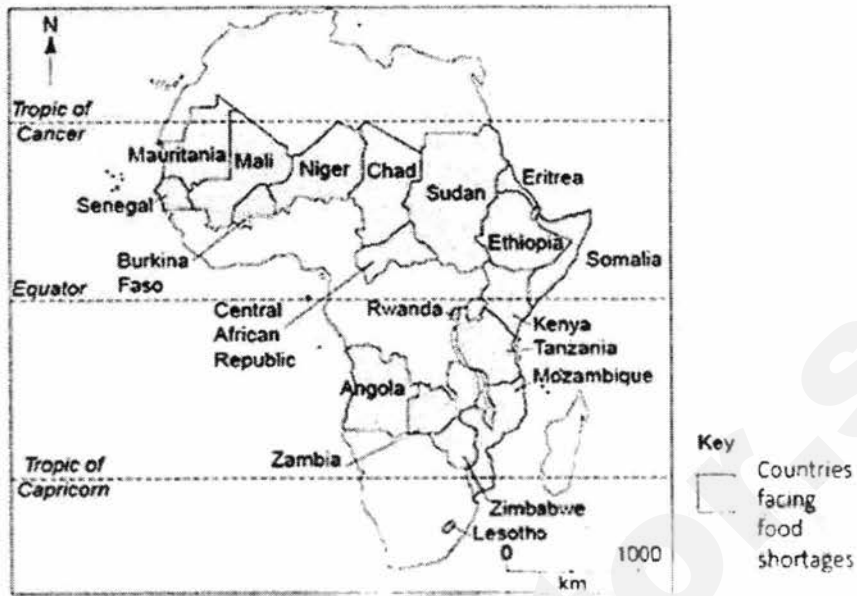
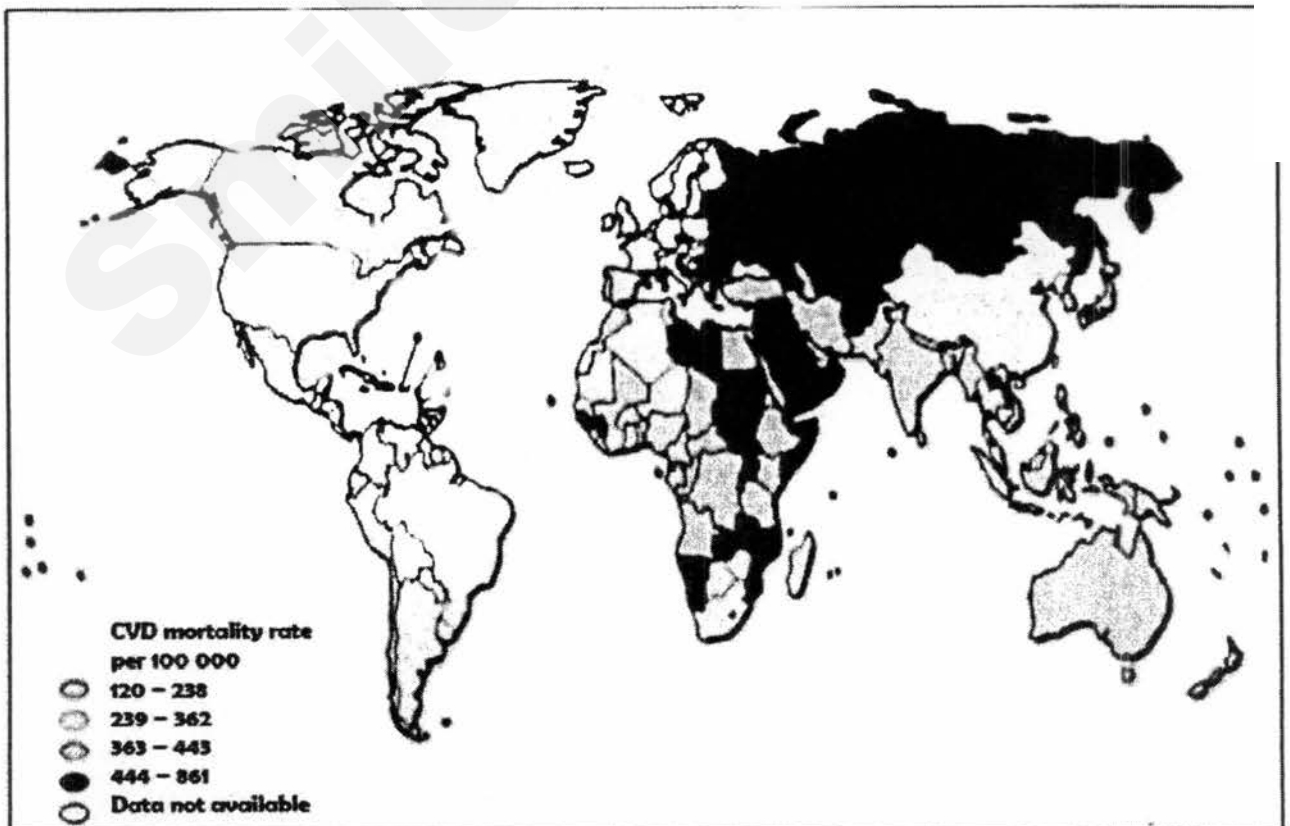

Fig. 10

www.cluva.eu/.../CLUVA_Climate-change-and-vulnerability-of-African-cities

Insert

Fig. 11 for question 4 (b)



Global Atlas on CVD:World Health Organisation

SmileTutor.sg



TEMASEK SECONDARY SCHOOL
O Level Preliminary Examinations 2017
Secondary Four Express

GEOGRAPHY

2236/01

Paper 1

1 hour 40 minutes

Question Booklet

Additional Material: 5 pieces of writing paper, 1 piece of graph paper and 1 Insert

READ THESE INSTRUCTIONS FIRST

Do not open the booklet until you are told to do so.

You are not required to submit this booklet at the end of the paper.

Write your name, index number and class on all the work you hand in.

Write in dark blue or black pen on both sides of the paper.

You may use a soft pencil for any diagrams or rough working.

Do not use staples, paper clips, glue or correction fluid.

Section A

This question is compulsory.

Section B

Answer **one** question.

The Insert contains Map 1 for Question 1, Fig. 1 for Question 2a, Map 2 for Question 2d and Fig. 2 for Question 3b.

Candidates should support their answers with the use of relevant examples.

Sketch maps and diagrams should be drawn whenever they serve to illustrate an answer.

At the end of the examination, fasten all your work securely together.

The number of marks is given in brackets [] at the end of each question or part question.

This document consists of 5 printed pages and 1 blank page.

Section A

This question is compulsory.

1 A group of students are interested in the reasons why tourists visit Cheung Chau, Hong Kong. They decided to collect information for a day at the Cheung Chau ferry pier during the Cheung Chau's bun festival in May. Study Map 1 (Insert), which shows the fieldwork site.

(a) State a possible hypothesis and describe how the data can be collected. [4]

(b) Study Table 1, which shows the reasons why tourists visit Cheung

Chau.

Interested in the bun festival	35
Interested to visit the Cheung Po Tsai's Cave	10
Interested in the scenic views	15

Table 1

- (i) Comment on the reliability of the data collected. [3]
- (ii) Plot a pie chart to represent the data shown in Table 1. [3]
- (c) Students are also interested to investigate the environmental impacts of tourism on Cheung Chau. Study Table 2, which shows the data collected from the perception survey conducted.

Negative aspects	-2	-1	0	1	2	Positive aspects
A lot of litter	2	3	1	4	0	No litter
High pedestrian count	1	4	2	2	1	Low pedestrian count
Buildings in poor state of repair	1	3	0	6	0	Well-tended buildings
Unpleasant surroundings	2	2	0	3	3	Pleasant surroundings

Table 2

- (i) Describe the advantages and disadvantages of conducting a perception survey. [4]
- (ii) The students concluded that tourism has resulted in negative impacts on the environment. Does the data in Table 2 support the conclusion? Explain your answer. [3]
- (d) The group of students decided to visit a beach near the Cheung Chau ferry pier to investigate if deposition is more prominent than erosion. The students measured the wave frequency at a location. Study Table 3, which shows the data collected.

Reading	Time (Waves/min)
1 st	12
2 nd	10
3 rd	7
4 th	11
5 th	13

Table 3

- (i) Describe how the students measure wave frequency. [2]
- (ii) What are some possible safety precautions the students had to take when measuring the wave frequency? [2]
- (iii) Suggest one possible factor that may affect the accuracy of the data collected. [1]
- (iv) What conclusion(s) can the students make? [3]

Section B

Answer one question from this section.

- 2 (a) Study Fig. 1 (Insert), which shows the distribution of coral reefs in the world.)

With reference to Fig. 1, describe the distribution of coral reefs and explain its importance. [5]

- (b) Study Photograph A, which shows a form of coastal protection measure implemented.)



Photograph A

With reference to Photograph A, identify X and assess its effectiveness in protecting the coastline. [3]

- (c) With reference to examples, comment on the effectiveness of non-governmental organisations and the local communities in ensuring sustainable tourism. [5]

- (d) Study Map 2 (Insert), which shows a map of the Grand Canyon National Park in the USA.)

With reference to Map 2, explain how creating a National Park helps to conserve the quality of the natural environment. [4]

- (e) 'International tourism encourages the development of a country's

Map 1
Figure 1 for Question 2a

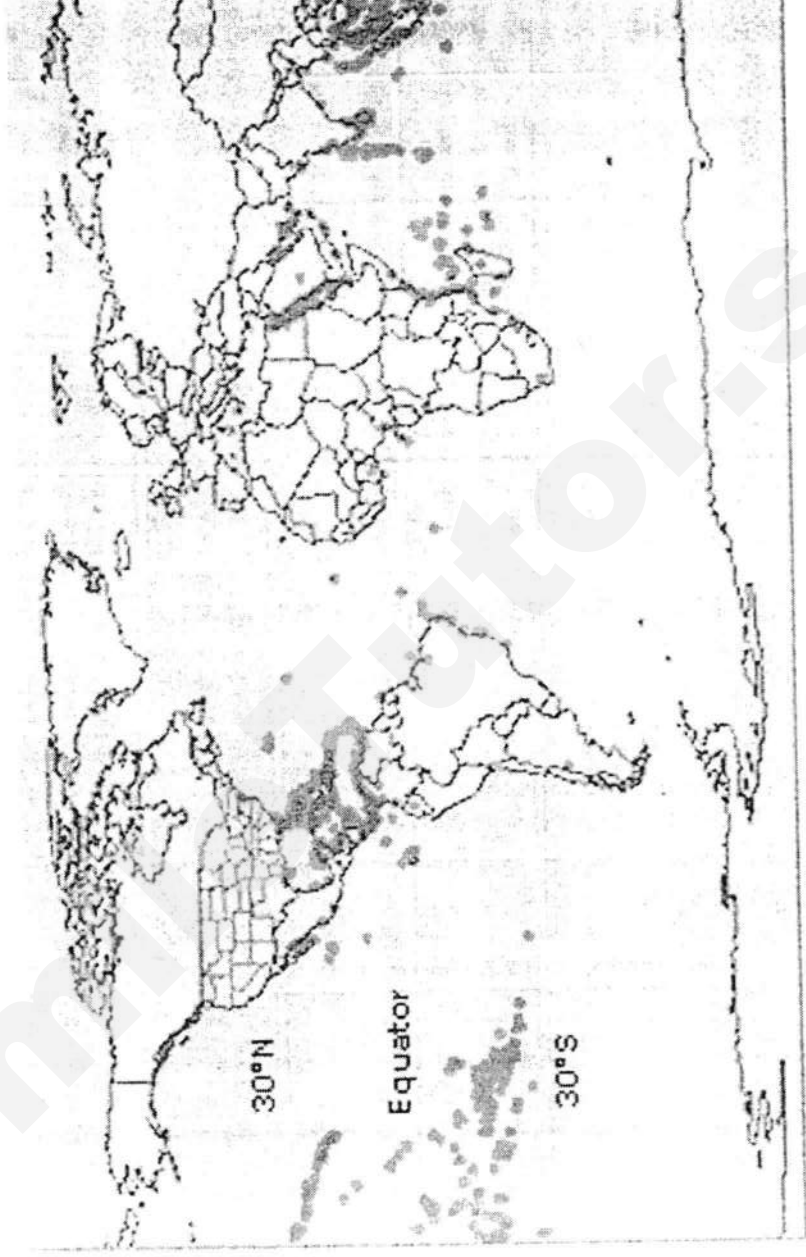

■ Areas in which coral reefs are found

Map 2 for Question 2d

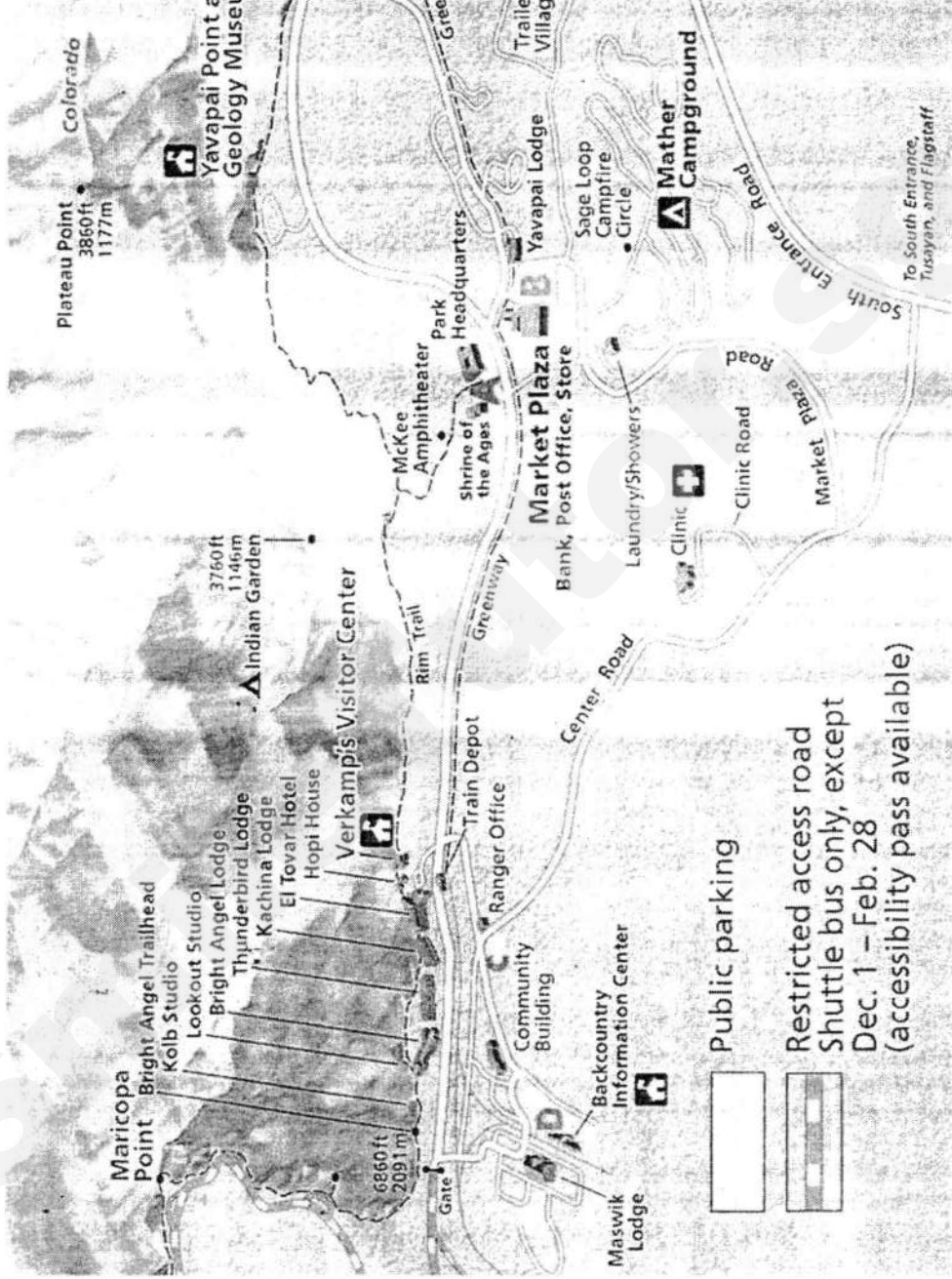

Map 2
Figure 2 for Question 3b





TEMASEK SECONDARY SCHOOL
O Level Preliminary Examinations 2017
Secondary Four Express

GEOGRAPHY

2236/01

Paper 1

1 hour 40 minutes

Answer Scheme

This document consists of **10** printed pages.

No part of the paper is to be reproduced without the approval of the Principal of Temasek Secondary School.

Need a home tutor? Visit smiletutor.sg

Section A

Answer one question from this section.

1	A group of students are interested in the reasons why tourists visit Cheung Chau, Hong Kong. They decided to collect information for a day at the Cheung Chau ferry pier during the Cheung Chau's bun festival in May. Study Map 1 (Insert), which shows the fieldwork site.							
	(a) State a possible hypothesis and describe how the data can be collected.	[4]						
	<ul style="list-style-type: none"> • Tourists visit Cheung Chau because of the bun festival. *compulsory • Students to conduct stratified sampling to differentiate between locals and tourists. • Systematic sampling to be conducted. • Sample size of 30 tourists • Interview questions such as why did you visit Cheung Chau can be asked <p><i>Award 1m for any 1 point</i></p>							
	<p>(b) Study Table 1, which shows the reasons why tourists visit Cheung Chau.</p> <table border="1" data-bbox="450 1173 1120 1339" style="margin-left: auto; margin-right: auto;"> <tr> <td>Interested in the bun festival</td> <td>35</td> </tr> <tr> <td>Interested to visit the Cheung Po Tsai's Cave</td> <td>10</td> </tr> <tr> <td>Interested in the scenic views</td> <td>15</td> </tr> </table> <p style="text-align: center;">Table 1</p>	Interested in the bun festival	35	Interested to visit the Cheung Po Tsai's Cave	10	Interested in the scenic views	15	
Interested in the bun festival	35							
Interested to visit the Cheung Po Tsai's Cave	10							
Interested in the scenic views	15							
	(i) Comment on the reliability of the data collected.	[3]						
	<ul style="list-style-type: none"> • Students conducted the survey during the bun festival which resulted in many respondents indicated that as their reason for visiting. • Students only conducted the survey for a day. • Students can conduct the survey for a longer period of time i.e. every weekend for a month. <p><i>Award 1m for any 1 point</i></p>							
	(ii) Plot a pie chart to represent the data shown in Table 1.	[3]						
	<ul style="list-style-type: none"> • Title • Accurate plotting • Legend 							
	(c) Students are also interested to investigate the environmental impacts							

of tourism on Cheung Chau. Study Table 2, which shows the data collected from the perception survey conducted.

Negative aspects	-2	-1	0	1	2	Positive aspects
A lot of litter	2	3	1	4	0	No litter
High pedestrian count	1	4	2	2	1	Low pedestrian count
Buildings in poor state of repair	1	3	0	6	0	Well-tended buildings
Unpleasant surroundings	2	2	0	3	3	Pleasant surroundings

Table 2

(i) Describe the advantages and disadvantages of conducting a perception survey. [4]

Advantages:

- Easy to administer
- Easy to represent data collected in a bipolar graph

Disadvantages:

- The different criteria in the bipolar survey form are subjective
- Visitors may not know the areas well /long time effectively
- Thus, these visitors may not be able to comment on the points effectively and can only rely on guessing.

Reserve 2m for advantages

Reserve 2m for disadvantages

(ii) The students concluded that tourism has resulted in negative impacts on the environment. Does the data in Table 2 support the conclusion? Explain your answer. [3]

- The data does not support the conclusion fully.
- In terms of amount of litter (-7) and pedestrian count (-6), there seems to be more negative responses.
- However, there are more positive responses for maintenance of buildings (+6) and surroundings (+9).

Award 1m for any 1 point

(d)	The group of students decided to visit a beach near the Cheung Chau ferry pier to investigate if deposition is more prominent than erosion. The students measured the wave frequency at a location. Study Table 3, which shows the data collected.													
	<table border="1" data-bbox="415 425 1081 672"> <thead> <tr> <th>Reading</th> <th>Time (Waves/min)</th> </tr> </thead> <tbody> <tr> <td>1st</td> <td>12</td> </tr> <tr> <td>2nd</td> <td>10</td> </tr> <tr> <td>3rd</td> <td>7</td> </tr> <tr> <td>4th</td> <td>11</td> </tr> <tr> <td>5th</td> <td>14</td> </tr> </tbody> </table> <p data-bbox="695 705 816 750" style="text-align: center;">Table 3</p>	Reading	Time (Waves/min)	1 st	12	2 nd	10	3 rd	7	4 th	11	5 th	14	
Reading	Time (Waves/min)													
1 st	12													
2 nd	10													
3 rd	7													
4 th	11													
5 th	14													
(i)	Describe how the students measure wave frequency.	[2]												
	<ol style="list-style-type: none"> 1. Place a ruler into the water and count the number of times the crest of the waves hit the ruler at in a minute. 2. Repeat the step 5 times to collect 5 readings. <p><i>Award 1m for any 1 point</i></p>													
(ii)	What are some possible safety precautions the students had to take when measuring the wave frequency?	[2]												
	<ul style="list-style-type: none"> • Ensure that everyone wears cover shoes – protection against sharp objects in the water • Ensure that students keep to the water's edge and not go beyond shin-deep water • Ensure that students do not have their back facing the sea • Students should not go to near to the pier to avoid the boats <p><i>Award 1m for any 1 point</i></p>													
(iii)	Suggest one possible factor that may affect the accuracy of the data collected.	[1]												
	<ul style="list-style-type: none"> • Movements of the boats at the ferry pier may increase the wave frequency. • Increase in wind speed may increase the wave frequency. <p><i>Award 1m for any 1 point</i></p>													

	(iv)	What conclusion(s) can the students make?	[3]
		<ul style="list-style-type: none"> Erosion is more prominent / Destructive waves EV: 4 of the readings fall within the range of 10 to 14 waves per min Anomaly: 3rd reading whereby wave frequency was only 7 waves per min <p><i>Award 1m for any 1 point</i></p>	

Section B

Answer one question from this section.

2	(a)	Study Fig. 1 (Insert), which shows the distribution of coral reefs in the world.	
		With reference to Fig. 1, describe the distribution of coral reefs and explain its importance.	[5]
		<p>Distribution:</p> <ul style="list-style-type: none"> Mostly found between Tropics of Cancer and Capricorn / 30°N to 30°S It is located on the coastal regions of Central America, Western coasts of Africa and in most parts of Southeast Asia. <p>Importance:</p> <ul style="list-style-type: none"> Stabilising shoreline – dissipate wave energy which prevents erosion and encourage deposition Breeding ground for marine animals – marine animals live around the corals and larger animals prey on smaller creatures. Jewellery and ornaments – corals can be sold as souvenirs to tourists, generating income for locals Wood for fuel – charcoal for burning to produce heat for households Tourism – ideal diving spots for tourists which generates jobs and income for locals <p><i>Reserve 2m for distribution (Award 1m for any 1 point)</i> <i>Reserve 3m for importance (Award 1m for any 1 point)</i></p>	

(b)	Study Photograph A, which shows a form of coastal protection measure implemented.	
	 <p style="text-align: center;">Photograph A</p>	
	With reference to Photograph A, identify X and assess its effectiveness in protecting the coastline.	[3]
	<ul style="list-style-type: none"> • Breakwater • Benefit: dissipate the force of oncoming waves, creating a zone of calm water behind it for deposition to occur • Limitation: protects the coast unevenly, <p><i>Award 1m for any 1 point</i> <i>Answer must include both benefits and limitations to award full marks</i></p>	
(c)	With reference to examples, comment on the effectiveness of non-governmental organisations and the local communities in ensuring sustainable tourism.	[5]
	<p><u>Non-governmental organisations (The International Ecotourism Society TIES)</u></p> <p>Strengths:</p> <ul style="list-style-type: none"> • NGOs are able to facilitate communications between various stakeholders by providing channels for communication / encouraging other stakeholders to actively participate in managing the impacts of tourism. • NGOs can provide manpower and expertise support, or marketing campaigns to manage the impacts of tourism. <p>Limitations:</p> <ul style="list-style-type: none"> • NGOs may face difficulties obtaining external funding, hampering efforts to manage the impacts of tourism. <p>Locals (e.g. Candirejo Village in Indonesia)</p>	

	<p>Strengths:</p> <ul style="list-style-type: none"> Locals are directly involved in decision making, will be more mindful in ensuring that the policies implemented will not harm the environment and put the community at a disadvantage. Locals often prioritise the community by ensuring that the people gain employment <p>Limitations:</p> <ul style="list-style-type: none"> NGOs may face difficulties obtaining external funding / shortage of skilled labour <p><i>Award 1m for each strength / limitation</i> <i>Reserve 2m for local communities strength and limitation</i> <i>Reserve 2m for NGOs strength and limitation</i> <i>Reserve 1m for examples from local communities and NGOs</i></p>	
(d)	<p>Study Map 2 (Insert), which shows a map of the Grand Canyon National Park in the USA.</p> <p>With reference to Map 2, explain how creating a National Park helps to conserve the quality of the natural environment.</p>	[4]
	<p>[1] Restricted access roads limit the number of visitors to the area [1] Presence of rangers to help protect the area [1] Yavapai Point and Geology Museum educate visitors on the area [1] Presence of trails such as the Rim Trail protects vegetation / less damage to the environment</p> <p>*Compulsory to identify elements from the map to match explanation</p>	
(e)	<p>'International tourism encourages the development of a country's economy.' How far do you agree with this statement? Support your answer using examples.</p>	[8]
	<ul style="list-style-type: none"> Agree – Economic development due to job opportunities / income growth / infrastructure development Disagree – Underuse of facilities / shortage of services / leakage <p>Level 1 At this level, answers will lack detail and may be general in nature. A basic answer that has little development. This will most likely be naming or brief descriptions of impacts.</p> <p>Level 2 At this level, answers will contain some appropriate detail. The content will lack balance and some relevant detail. This means that only economic impact is mentioned. Or impacts are considered, but support is patchy so that the answer is not full. Evaluation may be given but may be limited or general in nature.</p> <p>Level 3 At this level, answers will be comprehensive and supported by</p>	

	sound knowledge. There will be evaluations of the extent to how far the statement is true. Examples will be well used to support answer.	
--	--	--

SmileTutor.sg



TEMASEK SECONDARY SCHOOL
Preliminary Examination 2017
Secondary Four Express

GEOGRAPHY

2236/02

Paper 2

1 hour 45 minutes

Answer Scheme

SmileTutor.sg

Section A

Answer one question from this section.

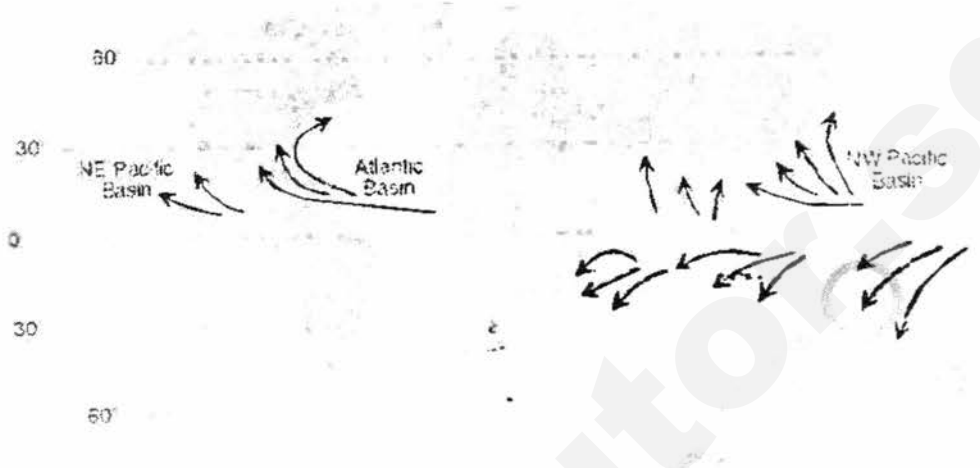
1	(a) Study Fig. 1, which shows the distribution and movement of cyclones.	
 <p style="text-align: center;">Fig. 1</p>		
<p>With reference to Fig. 1, describe and account for the distribution and movement of cyclones.</p>		[5]
<ul style="list-style-type: none"> • Tropical cyclones are often developed between latitudes of 8° and 45° north and south of the equator [1] as Coriolis effect is the strongest [1] or / Cyclones do not develop at the equator [1] as Coriolis effect is the weakest [1] • Cyclones deflect to the right and left in the northern and southern hemisphere respectively [1] – due to Coriolis effect [1] • Developed over warm oceans in the tropics [1] – Warm surface temperature of the sea (above 26.5°C) needed for heat and moisture to sustain the energy of the cyclones [1] <p><i>Reserve 2m for description (1m for each point)</i> <i>Reserve 2m for account (1m for each point)</i></p>		

(b) Study Fig. 2, which shows a climograph of a country.

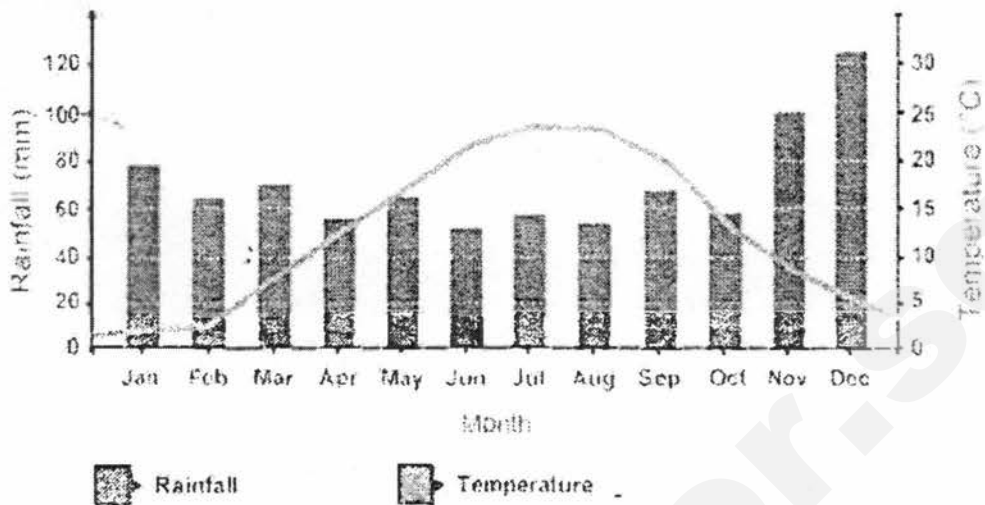

Fig. 2

Identify the climatic type and describe its temperature and rainfall patterns.

[5]

- Cool temperate climate
- Moderate total annual rainfall (about 810mm)
- Even distribution of rainfall throughout the year with the exception of Nov and Dec
- Large annual temperature range (20°C)
- High mean annual temperature (26.7°C)

Award 1m for each point (description must be accompanied with EV)

(c) Study Fig. 3 (Insert), which shows a before and after satellite image of the 2004 Banda Aceh tsunami.

(i) With reference to Fig. 3, describe the changes to Banda Aceh before and after the tsunami.

[3]

- Banda Aceh has shrunk/reduced in size
- The northern shoreline used to be straight. After the tsunami, the shoreline has become highly irregular.
- The northern coast and south-eastern coast experienced the greatest destruction due to flooding / road and building are destroyed.
- The trees / forests along the South coastline has been destroyed.

Award 1m for any 1 point

(ii) Outline the social and economic impacts of a tsunami.

[4]

	<p><u>Social:</u></p> <ul style="list-style-type: none"> • Destruction of settlements ⑦ people become homeless • Contamination of drinking water due to damaged water and sewage pipes ⑦ people contract water-borne diseases and fall ill • Damaging infrastructure such as communication networks ⑦ Disruption hinders rescue efforts ⑦ Increasing death toll due to delays • Flooding resulting in loss of crops ⑦ Decrease in food supply leading to starvation <p><u>Economic:</u></p> <ul style="list-style-type: none"> • Delay in businesses as shops and offices are destroyed ⑦ loss of income for locals / hinder economic growth • Destruction of infrastructure ⑦ costly for government to rebuild, diverting financial resources away from other areas such as education • Flooding resulting in loss of crops ⑦ Loss of income for farmers <p><i>Reserve 2m for social impacts (1m for each point)</i> <i>Reserve 2m for economic impacts (1 mark for each point)</i> <i>Accept any plausible impacts</i></p>	
(d)	<p>"Prediction and early warning is the most important factor in ensuring the survival of people during a natural disaster." Do you agree with this statement? Support your answer with evidences.</p>	[8]
	<ul style="list-style-type: none"> • Prediction and early warning • Emergency drills • Land use controls • Building design • Provision of aid (medical, food and water) • Search and rescue <p>Level 1/ 0 - 3 marks At this level answers will be generalized or with minimal support if any stand was given at all. Reasoning rather weak and expression may be unclear. A basic answer that has little development.</p> <p>Level 2/ 4 - 6 marks At this level answers will contain some appropriate detail. The content will lack balance and some relevant detail. This means that only one side of the issue is explored. Or other factors are considered, but support and patchy so that the answer is not full. Assessment may be given but may be general in nature. An example will be presented to support answers in at least one place in the answer.</p> <p>Level 3/ 7-8 marks At this level answers will be comprehensive and supported by sound knowledge. There will be assessment of the extent to which the statement is true. Examples to support answers can be found in most places in the answer.</p>	

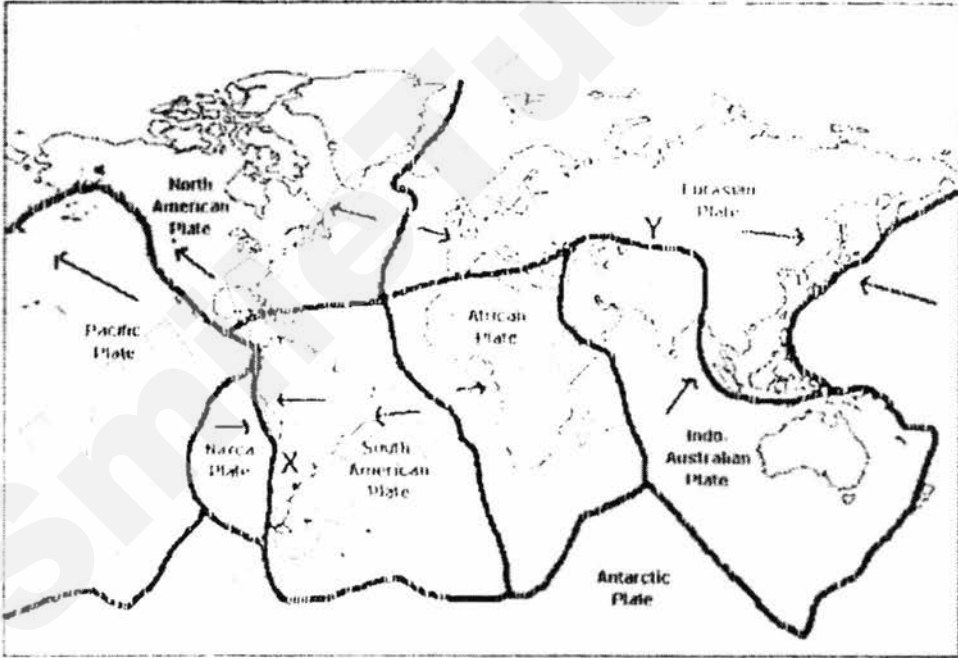
2	(a) Outline the dangers a volcanic eruption may pose.	[5]
	<ul style="list-style-type: none"> • Destruction by volcanic materials ⑦ Lava and pyroclasts can destroy properties • Landslides due to structural collapse of volcanic cone ⑦ obstruct roads • Landslides due to structural collapse of volcanic cone ⑦ block the flow of river and lead to flooding • Pollution ⑦ dust particles can cause severe respiratory problems to people • Pollution ⑦ dust particles pose dangers to aircraft engines and structures ⑦ cancelling and delaying flights <p><i>Award 1m for each point</i> <i>Accept any plausible impacts</i></p>	
	(b) Study Fig. 4, which shows the location of two fold mountains, X and Y.	
	 <p style="text-align: center;">Fig. 4</p>	
	(i) With reference to Fig. 4, identify the names of the fold mountains, X and Y.	[1]
	X: Andes and Y: Himalayas	
	(ii) Compare the tectonic processes taking place at X and Y, and suggest why one landform is taller than the other.	[5]
	<ul style="list-style-type: none"> • Y is taller 	<p style="text-align: right;">Need a home tutor? Visit smiletutor.sg</p>

- Both occur along convergent plate boundaries
- Mountains at area X are formed by 2 continental plates, Eurasian and Indo-Australian plates, while that at Y, involves continental South American and oceanic Nazca plate.
- Only folding of the continental places take place at X. As continental plates are both light and buoyant, they continue to push against one another and become taller.
- At Y, South American plate rides over the subducting Nazca plate so only the edges of the continental crust of the South American plate folds to forms Y which are shorter.

(c) Study Figs. 5 and 6, which shows the distribution of earthquakes and plate boundaries in Japan respectively.

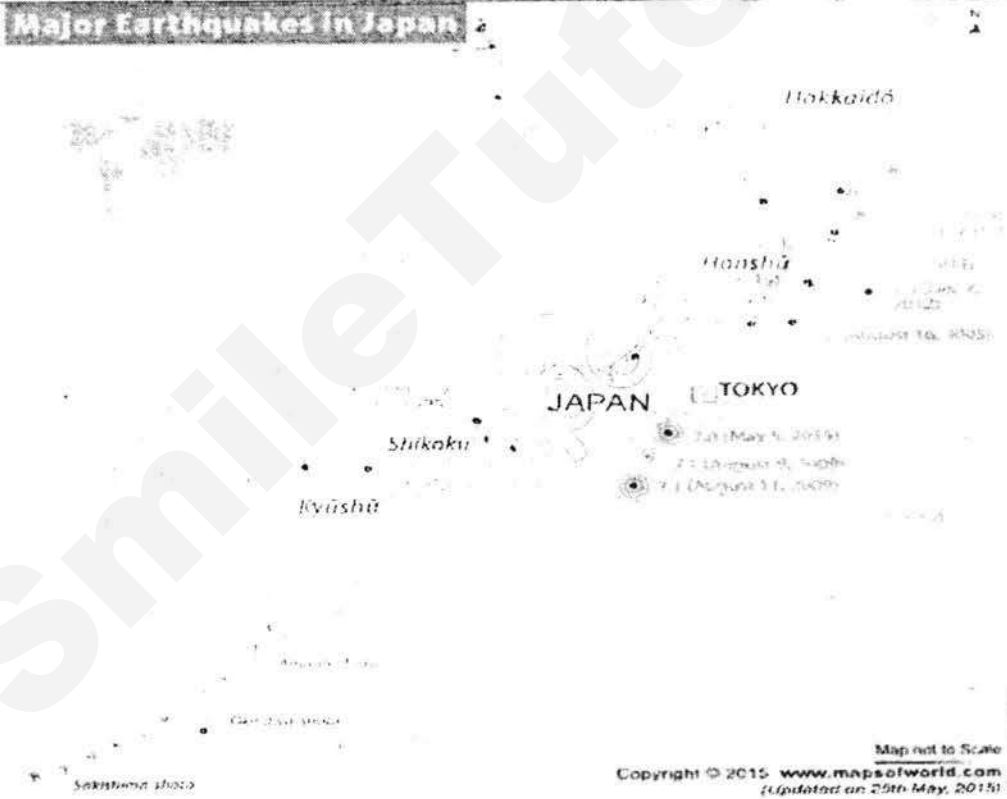

Fig. 5

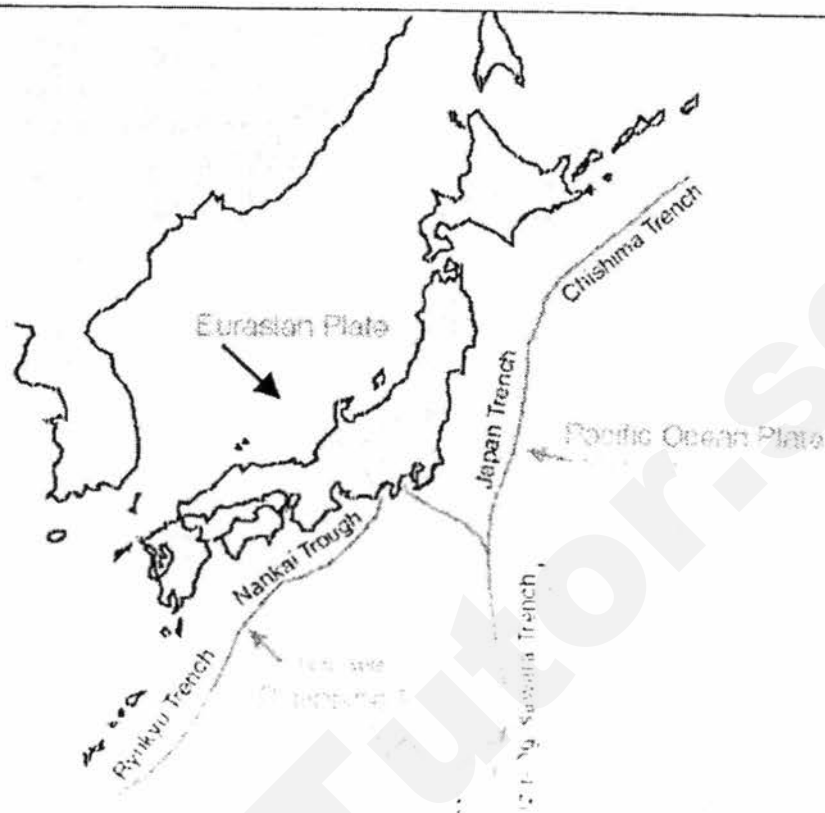

Fig. 6

With the help of Fig 5 and 6, describe and explain the distribution of earthquakes of different magnitudes in Japan. [6]

Distribution:

- Most of the earthquakes occurred in close proximity to the plate boundary
- Earthquakes of higher magnitude (above 7.1) are found closer to the plate boundary while earthquakes of lower magnitude (about 6) are found further away.
- Earthquakes of higher magnitude (above 7.1) are found in the water / at the eastern coast of Japan.

Explanation:

- Converging movement of the Eurasian and Pacific Plate is not smooth/ encounters a lot of friction
- Pressure/stress builds up
- Energy is released as seismic waves
- Further away from plate boundaries ⑦ Greater energy is loss as seismic waves have to take a longer time to reach

Reserve 2m for distribution (Award 1m each)

Reserve 4m for explanation (Award 1m each)

(d) "Liquefaction is the most important factor in determining the extent of

	<p>damage caused by earthquakes." To what extent do you agree with this statement? Support your answer with evidences.</p>	[8]
	<ul style="list-style-type: none"> • Liquefaction • Time of occurrence • Level of preparedness • Population density • Time to occurrence • Magnitude <p>Level 1/ 0 - 3 marks At this level answers will be generalized or with minimal support if any stand was given at all. Reasoning rather weak and expression may be unclear. A basic answer that has little development</p> <p>Level 2/ 4 - 6 marks At this level answers will contain some appropriate detail. The content will lack balance and some relevant detail. This means that only one side of the issue is explored. Or other factors are considered, but support and patchy so that the answer is not full. Assessment may be given but may be general in nature. An Example, will be presented to support answers in at least one place in the answer.</p> <p>Level 3/ 7-8 marks At this level answers will be comprehensive and supported by sound knowledge. There will be assessment of the extent to which the statement is true. Examples to support answers can be found in most places in the answer.</p>	

This question is compulsory

- 3 (a) Study Fig. 7, which shows the relationship between infant mortality rate and gross domestic product (GDP) per capita.

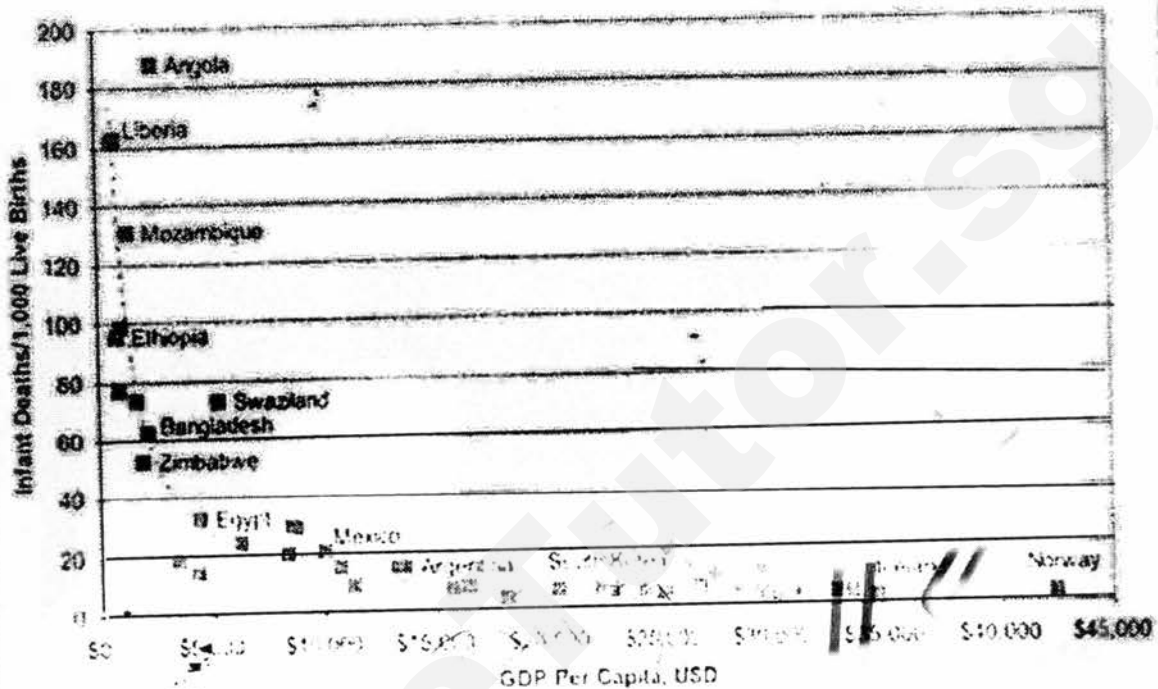

Fig. 7

With reference to Fig. 7, account for the relationship between infant mortality rate and GDP per capita. [6]

Trend:

- The higher the GDP per capita, the lower the infant mortality rate
Evidence – Norway has a higher GDP per capita (about USD \$43,000) and lower infant mortality rate (about 5 infant deaths for every 1000 live births) while Liberia has a lower GDP per capita (about USD \$500) and higher infant mortality rate (about 163 infant deaths for every 1000 live births)
- Anomaly – Swaziland has a higher GDP per capita (about USD \$5,000) and higher infant mortality rate (about 75 infant deaths for every 1000 live births) than Bangladesh which has a lower GDP per capita (about USD \$2,000) and lower infant mortality rate (about 62 infant deaths for every 1000 live births).

Account:

- Affluence - people able to afford to seek better quality medical treatments / receive vaccinations against diseases and boost the immunity of infants
- Affluence – better living conditions – access to clean drinking water / proper sanitation which prevents infants from contracting water-borne diseases

	<p>for their child to prevent them from falling ill</p> <ul style="list-style-type: none"> • Investment in healthcare in developed countries – higher doctor-patient ratio / bed-patient ratio thereby increasing the accessibility of healthcare • Investment in healthcare in developed countries – advanced medical treatments available <p><i>Reserve 2m for description (1m for each trend and 1m for accompanying EV)</i> <i>Reserve 4m for account (1m for any point) – accept any plausible reasons</i></p>	
(b)	<p>With the use of examples, explain why authorities are unable to eradicate malaria.</p>	[5]
	<ul style="list-style-type: none"> • Lack of access to education – lack of knowledge on how take preventive measures against malaria • Limited healthcare – shortage of doctors and healthcare services (E.g. critical shortage of doctors in India: 6 doctors for every 10,000 people) / high cost of malaria treatments hence the poor are unable to afford treatment • Population movement – parasites can be transported to new areas (E.g. Malaria reported in Southern France in areas non-endemic to malaria and amongst people who had not travelled nor received blood transfusion) • Climate change* <ul style="list-style-type: none"> • Increase in temperature – increase the lifespan, and the frequency of bites, by mosquitoes (E.g. temperatures in the range of 22°C to 30°C) / shorten development time of parasites in the mosquito host resulting in mosquitoes become active and infectious sooner / Aquatic life cycle of mosquitoes (E.g. reduce from 20 day to 7 days) Or • Increase in precipitation (explanation similar to monsoon) and poor drainage / poor sanitation – stagnant water provide breeding ground for mosquitoes Or • Increase in relative humidity – increase the lifespan of mosquitoes (E.g. relative humidity between 50% to 60% is needed for the survival and activity of mosquitoes) • Overcrowding living conditions – disease can be transmitted easily as mosquitoes can go easily from person to person • Insecticide-resistant mosquitoes - Mosquitoes were able to build resistance in a short period of time (E.g. build resistance to pyrethroids) • Resistance to anti-malaria drugs – due to rise in use of counterfeit or incomplete doses of anti-malaria drugs, allowing malaria parasites to build resistance to the drugs (E.g. Indian migrant workers brought home surviving malaria parasites in their bodies that were resistant to the drugs, causing existing malaria treatments to be ineffective) <p><i>Reserve 3m for reasons (1m for each point)</i> <i>Reserve 2m for examples (1m for each example)</i></p>	

*Max 2m for explanation of climate change if students provide 2 reasons
Accept any plausible reasons

(c) Study Fig. 8, which shows the problems malaria pose.

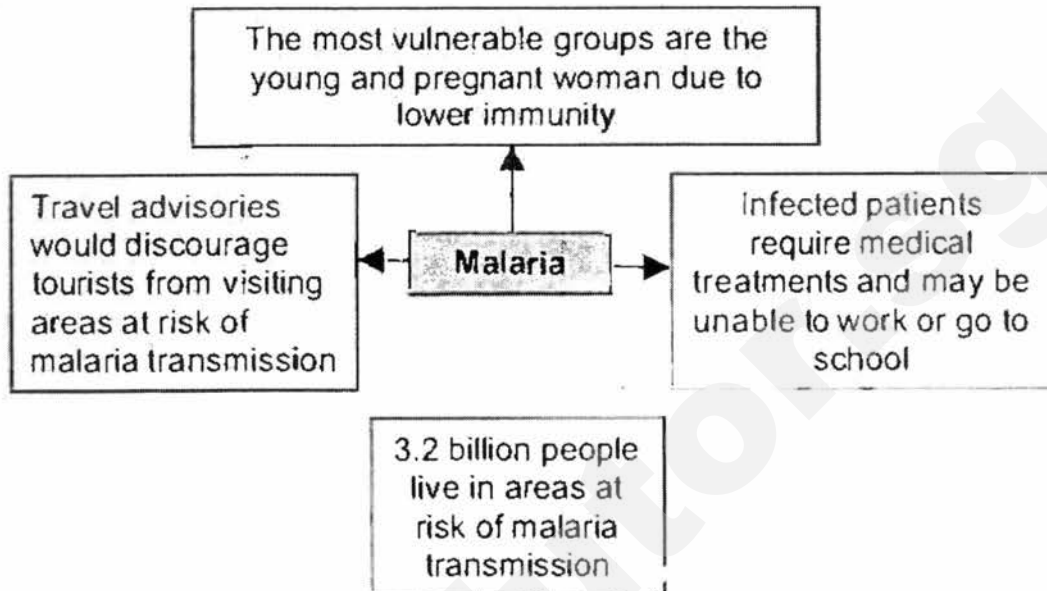

Fig. 8

With reference to Fig. 8, suggest problems malaria can pose to the citizens and government. [6]

Citizens:

- People may fall in and die
- Financial burden – people require high healthcare treatments which are expensive
- Loss of income – unable to work / school when they fall ill

Government:

- Decrease in productivity - slower economic growth
- Increase cost of healthcare – Increase in financial burden and diversion of resources from other areas such as education
- Decrease in tourism as tourists fear contracting malaria – decrease in tourist earnings / income
- Difficulty to manage this problem as many people are at risk of malaria transmission

Reserve 3m for problems citizens faces (1m for each point)

Reserve 3m for problems government faces (1m for each point)

Accept any plausible reasons

(d) "Lapses in medical practices is the main reason for the spread of Human Immunodeficiency Virus (HIV) and Acquired Immune Deficiency Syndrome (AIDS)." How far do you agree with this statement? Support

	your answer with evidence.	[8]
	<ul style="list-style-type: none"> • Lapses in medical practices – Compulsory point • Social stigma • Education • Lifestyle choices • Vice trades • Mobility <p>Level 1/ 0 - 3 marks At this level answers will be generalized or with minimal support if any stand was given at all. Reasoning rather weak and expression may be unclear. A basic answer that has little development.</p> <p>Level 2/ 4 - 6 marks At this level answers will contain some appropriate detail. The content will lack balance and some relevant detail. This means that only one side of the issue is explored. Or other factors are considered, but support and patchy so that the answer is not full. Assessment may be given but may be general in nature. An example will be presented to support answers in at least one place in the answer.</p> <p>Level 3/ 7-8 marks At this level answers will be comprehensive and supported by sound knowledge. There will be assessment of the extent to which the statement is true. Examples to support answers can be found in most places in the answer.</p>	
4 (a)	Study Fig. 9, which shows cotton yield in Arizona before and after the introduction of Bt cotton, a genetically modified crop .	Need a home tutor? Visit smiletutor.sg

Fig. 9

With reference to Fig. 9, describe and account for the trend.

[6]

Trend:

- Before 1996, Arizona produced non-Bt cotton increased gradually (by about 100lbs/A)
- However, after 1996, there is a sharp increase in the production on Bt cotton, by about 400 lbs/acre in 2013.

Account:

- Bt cotton has a shorter growing season, thus farmers are able to earn money within a shorter period of time
- They are more resistant to pests and diseases compared to non-Bt cotton, resulting in less damage to the crop
- Bt cotton is more resistant to extreme weather conditions, thus boosting productivity
- The government is able to increase export of Bt cotton to other countries, thus earning more foreign revenue which can be used for the development of the country / farmers increase Bt cotton production as it is an easier alternative to earn higher income

Reserve 2m for description (1m for point) – no marks for EV with no units

Reserve 4m for account (1m for any point) – accept any plausible reasons

(b) Explain how education can help improve the level of health in a country.

[5]

• Increase in knowledge, people become aware of safety precaution

	<p>measures to <u>prevent the spread of disease</u> [1]</p> <ul style="list-style-type: none"> • Improvement in lifestyle – people lead a healthier lifestyle with proper diet and exercise to <u>prevent themselves from falling ill</u> [1] • Educated workforce resulting is better economic development – government able to invest more in healthcare [1] by developing vaccinations / increasing doctor – patient ratio / increasing bed-patient ratio [1] • People are able to increase their income – better afford healthcare / able to live in better living conditions and prevent themselves from falling ill [1] <p><i>Accept any plausible reasons</i></p>	
(c)	Study Fig. 10, which shows the projected effects of AIDS on the major age groups in Botswana in 2025.	
	<p>Fig. 10</p>	
	Describe the projected effects of AIDS on the major age groups and predict the impacts it may have on Botswana's economy.	[6]
	<p>Trend:</p> <ul style="list-style-type: none"> • Generally, the older age groups (age 30 and above) will tend to die from AIDS • More females will die from AIDS (about 100,000 more woman die from AIDS between ages 30 and 64). • AIDS will result in fewer children / babies (300,000 children age 0-14 will die from AIDS) <p>Economic impacts:</p> <ul style="list-style-type: none"> • Higher death rate – shrinking of workforce and decrease in economic 	<p>Need a home tutor? Visit smiletutor.sg</p>

	<p>development</p> <ul style="list-style-type: none"> • People are unable to work / go to school – decrease in productivity • High proportion of people falling ill / less skilled and productive workforce– decrease in FDI • Treatments for AIDS is expensive – increase in healthcare expenditure for government and diverting funds away from other areas such as education and improving infrastructure <p><i>Reserve 2m for trends (1m for point)</i> <i>Reserve 4m for account (1m for any point) – accept any plausible reasons</i></p>	
(c)	Explain how education can help improve the level of health in a country.	[5]
-	<ul style="list-style-type: none"> • Increase in knowledge – people become aware of safety precaution measures to <u>prevent the spread of disease</u> [1] • Improvement in lifestyle – people lead a healthier lifestyle with proper diet and exercise to <u>prevent themselves from falling ill</u> [1] • Educated workforce resulting is better economic development – government able to invest more in <u>healthcare</u> [1] by developing vaccinations / increasing doctor – <u>patient ratio</u> / increasing bed-patient ratio [1] • People are able to increase their income – better afford healthcare / <u>able to live in better living conditions and prevent themselves from falling ill</u> [1] <p><i>Accept any plausible reasons</i></p>	
(d)	<p>"The government plays the most important role in managing the spread of infectious diseases." How far do you agree with this statement? Support your answer with evidences.</p>	[8]
	<ul style="list-style-type: none"> • Government – Compulsory point • Individuals • Community • International organisations <p>Level 1/ 0 - 3 marks At this level answers will be generalized or with minimal support if any stand was given at all. Reasoning rather weak and expression may be unclear. A basic answer that has little development.</p> <p>Level 2/ 4 - 6 marks At this level answers will contain some appropriate detail. The content will lack balance and some relevant detail. This means that only one side of the issue is explored. Or other factors are considered, but support and patchy so that the answer is not full. Assessment may be given but may be general in nature. An example will be presented to support answers in at least one place in the answer.</p> <p>Level 3/ 7-8 marks</p>	

	At this level answers will be comprehensive and supported by sound knowledge. There will be assessment of the extent to which the statement is true. Examples to support answers can be found in most places in the answer.	
--	---	--

SmileTutor.sg