

CONTINUAL ASSESSMENT 1 (2017)
PRIMARY 5
SCIENCE
BOOKLET A

THURSDAY

23 February 2017

1 HOUR

Name : _____ ()

Class : P5 _____

INSTRUCTIONS TO PUPILS

DO NOT TURN OVER THE PAGES UNTIL YOU ARE TOLD TO DO SO

Follow all instructions carefully.

There are 14 questions in this booklet.

Answer ALL questions.

INFORMATION FOR PUPILS

The total marks for this booklet is 28.

The total time for Booklets A and B is 1 hour.

This question paper consists of 9 printed pages (inclusive of cover page).

Booklet A (28 marks)

For each question from 1 to 14, four options are given. One of them is the correct answer. Make your choice (1, 2, 3 or 4). Shade your answer on the Optical Answer Sheet. (14 x 2 marks)

1. The classification chart shows how some things can be classified according to certain characteristics.

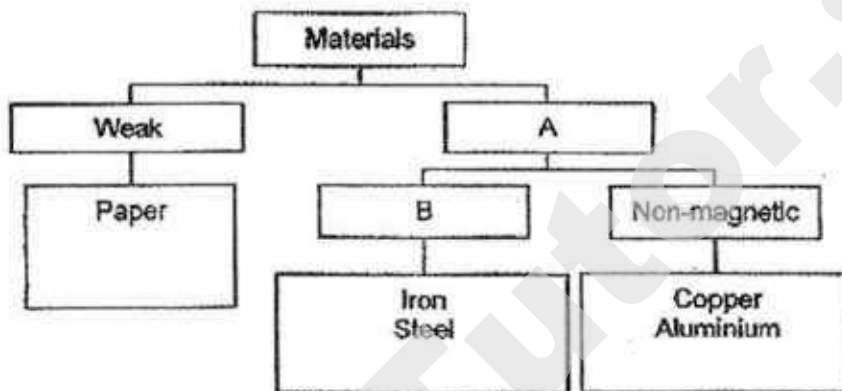

Which of the following clearly represents letters A, B and C?

	A	B
(1)	Flexible	Strong
(2)	Not flexible	Magnetic
(3)	Strong	Magnetic
(4)	Strong	Flexible

2. Jeremy studied and made some observations on two animals, X and Y. He recorded his observations in the table below.

	Animal X	Animal Y
Can the adult fly?	Yes	Yes
Does it lay its eggs in water?	Yes	No
Does the young look like its adult?	No	No
Does it have a larval stage in its life cycle?	Yes	Yes

Which of the following pair of animals can be Animal X and Animal Y?

	Animal X	Animal Y
(1)	Chicken	Grasshopper
(2)	Mosquito	Beetle
(3)	Butterfly	Mosquito
(4)	Cockroach	Chicken

3. Natalie carried out an experiment for 3 sunny days as shown below. She placed two identical type of plants in the boxes covered with black paper. She covered the leaves of the plant in Set-up B and placed both set-ups in a garden. She watered both plants with the same amount of water every day.

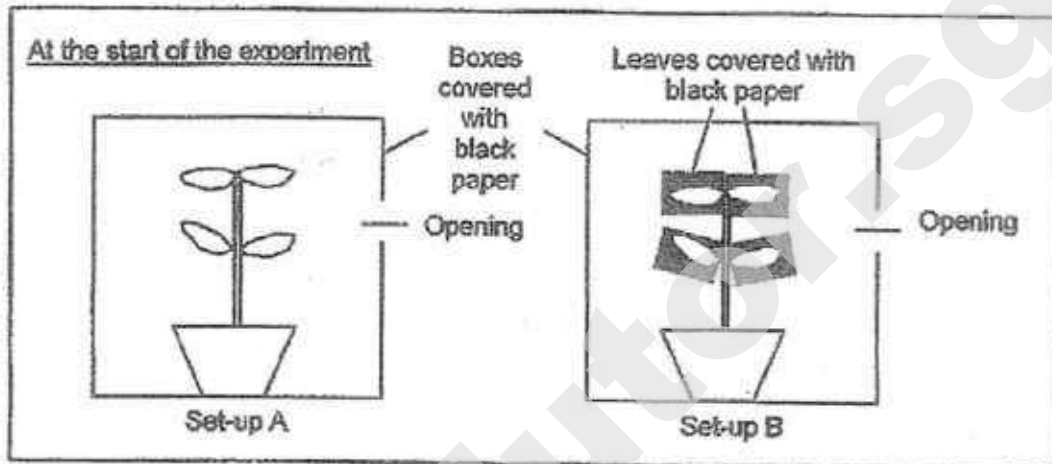

After 3 days, this is what she observed:

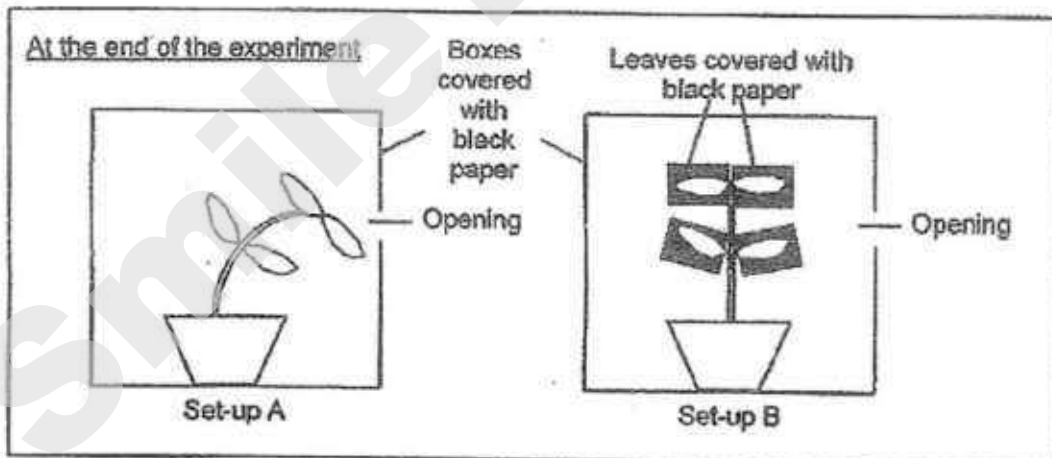

What was the aim of Natalie's experiment?

- (1) To find out if plants need air to survive.
- (2) To find out if plants need water to survive.
- (3) To find out if plants need leaves to make food.
- (4) To find out if plants respond to changes around them.

4. Study the flow chart below.

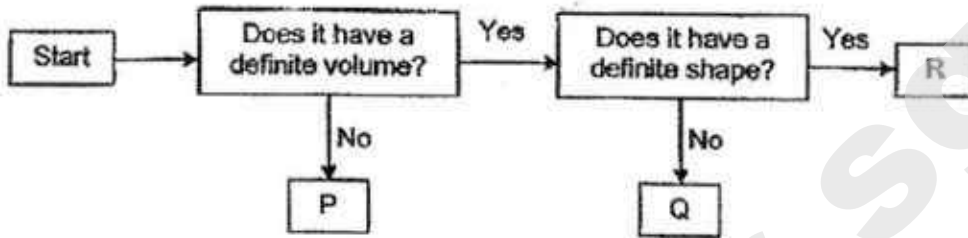

Which of the following correctly represents P, Q and R?

	P	Q	R
(1)	Water vapour	Coffee	Magnet
(2)	Magnet	Water	Book
(3)	Coffee	Book	Water vapour
(4)	Water vapour	Magnet	Book

5. John placed a toy car on a sheet of Material A and held a magnet under the sheet of Material A as shown in the diagram below.

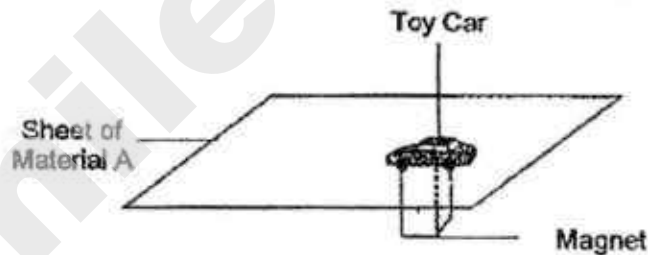

The toy car moved when John moved the magnet under the sheet of Material A. What conclusions can you make based on John's experiment?

- P Material A can be made of plastic.
 Q The magnet has lost its magnetism.
 R The toy car is made of magnetic material.

- (1) Q only
 (2) P and R only
 (3) Q and R only
 (4) P, Q and R

6. Which of the following substance(s) is/are present in the plant transport system?

- A blood
- B water
- C glucose
- D minerals

- (1) A and B only
- (2) C and D only
- (3) B, C and D only
- (4) A, B, C and D

7. The diagram below shows the human circulatory system. The arrows, W, X, Y and Z, represent the flow of blood.

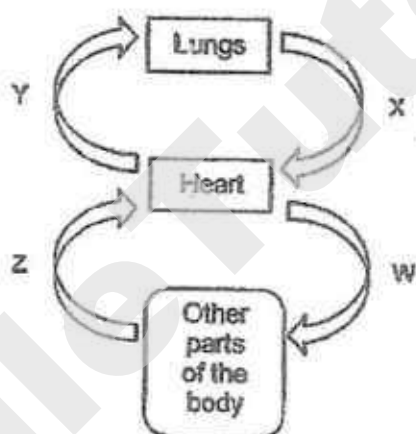

Which arrow(s) represent(s) the transport of blood rich in oxygen in the human circulatory system?

- (1) X only
- (2) W and X only
- (3) Y and Z only
- (4) W, Y and Z only

8. Gideon conducted an experiment to find out how much light could pass through four different materials, P, Q, R and S. He used a light sensor connected to a datalogger to measure the amount of light that passed through each material. The table below shows the amount of light that passed through each material.

Material	Amount of light (lux)
P	500
Q	0
R	300
S	600

Based on the table above, which one of the following statements is true?

- (1) Material R allows all the light to pass through it.
- (2) Material Q does not allow any light to pass through it.
- (3) Material S allows the least amount of light to pass through it.
- (4) Material P allows the most amount of light to pass through it.

9. Which of the following statements about the heart is/are true?

- A The heart pumps blood to the lungs only.
- B The heart stops beating when we are tired.
- C The heart receives blood rich in oxygen from the lungs.
- D The heart beats at the same rate when we sleep or run.

- (1) C only
- (2) B and D only
- (3) A, B and C only
- (4) A, C and D only

10. Rachael conducted an experiment. 4 identical pieces of wax were attached onto 4 rods, A, B, C and D, made of different materials as shown in the diagram below. The rods had the same length and diameter. Next, the four rods were placed at equal distance above a candle flame of same heat intensity at the same time.

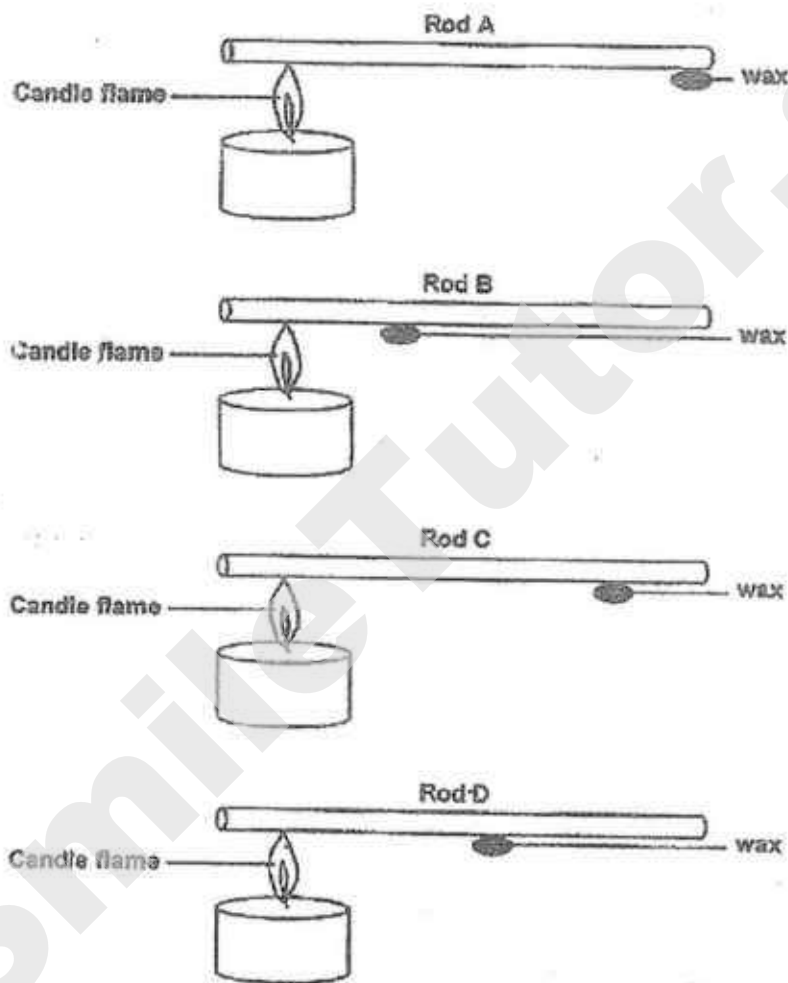

Later, Rachael observed that all the four pieces of wax melted at the same time.

Which of the following could Rachael conclude from this experiment?

- (1) Material of Rod A is the best conductor of heat.
- (2) Material of Rod B is the best conductor of heat.
- (3) Material of Rod C is the worst conductor of heat.
- (4) Material of Rod D is the worst conductor of heat.

11. The diagram below shows the cross-section of the stem of a plant. The stem of the plant was placed inside a beaker of blue-coloured water for 1 day as shown below. Tube A is coloured blue.

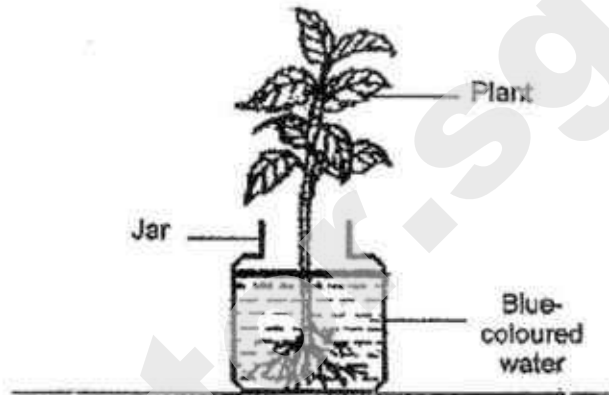
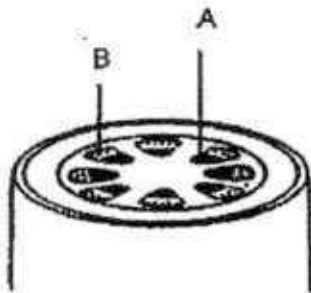

Which of the following statement(s) is/are correct?

- W Tube A is the food-carrying tube.
 X Tube B transports air to all parts of the plant.
 Y Tube B is stained blue by the blue-coloured water.
 Z Tube A transports the blue-coloured water to all parts of the plant.

- (1) Z only
 (2) X and Y only
 (3) W and Y only
 (4) W, X and Z only
12. Which of the following statement(s) about inhaled air is/are correct?

- A It contains only oxygen.
 B It is usually cooler than exhaled air.
 C It contains less water vapour than exhaled air.

- (1) A only
 (2) A and B only
 (3) B and C only
 (4) A, B and C

13. Read the following description of the human breathing process below.

- A Air enters the body through the nose.
- B Air leaves the body through the nose.
- C Blood transport carbon dioxide to the lungs.
- D Air travels through the windpipe and the lungs take in oxygen.
- E Oxygen passes into the blood and is transported to other parts of the body

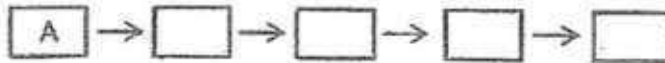

Arrange the description in the correct order to describe what happens when a person breathes in and out.

- (1) A → B → C → D → E
- (2) A → D → E → C → B
- (3) A → C → E → B → D
- (4) A → E → B → D → C

14. Which of the following statement(s) is/are true of all plants?

- J Only water-carrying tubes can be found in the stem.
- K Excess food is stored only in the fruits and roots of the plant.
- L Food-carrying tubes are found in the different parts of the plant.

- (1) J only
- (2) L only
- (3) J and K only
- (4) K and L only

End of Booklet A

**CONTINUAL ASSESSMENT 1 (2017)
PRIMARY 5**

**SCIENCE
BOOKLET B**

THURSDAY

23 February 2017

1 HOUR

Name : _____ ()

Class : P5 _____

INSTRUCTIONS TO PUPILS

DO NOT TURN OVER THE PAGES UNTIL YOU ARE TOLD TO DO SO

Follow all instructions carefully.

There are 7 questions in this booklet.

Answer **ALL** questions.

INFORMATION FOR PUPILS

The number of marks is given in brackets [] at the end of each question or part question.

The total marks for this booklet is 22.

The total time for Booklets A and B is 1 hour.

This question paper consists of 9 printed pages (inclusive of cover page).

BOOKLET A	/ 28
BOOKLET B	/ 22
TOTAL	/ 50
Parent's signature/ Date:	

Booklet B (22 marks)

For questions 15 to 21, write your answers in this booklet.

The number of marks available is shown in brackets [] at the end of each question or part question.

15. (a) The flow chart shows the descriptions of four living things.

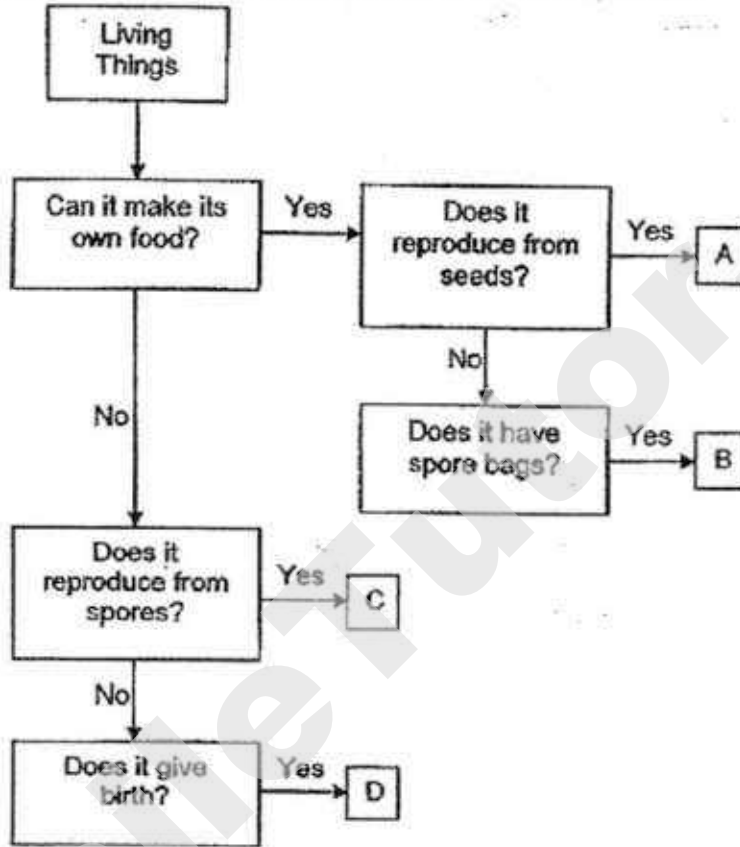

(i) Which letter (A, B, C or D) represents mushroom and rabbit? [1]

Mushroom : _____

Rabbit : _____

(ii) Based on the flowchart, what is the difference between living things A and B? [1]

(Go on to the next page)

SCORE	
	2

- 15(b). The table below gives information about four animals, P, Q, R and S, based on some characteristics. A tick (✓) shows that the animal has the characteristic and a cross (×) shows that the animal does not have that characteristic.

Characteristics	Animals			
	P	Q	R	S
Has hair on its body	✓	×	×	×
Needs air, water and food	✓	✓	✓	✓
Breathes through moist skin	×	✓	×	×
Has dry skin covered with scales	×	×	✓	×
Has six legs and 3 body segments	×	×	×	✓

- (i) Fill in the boxes with one of the letters, P, Q, R or S, in the classification table below. Use each letter once only. [1]

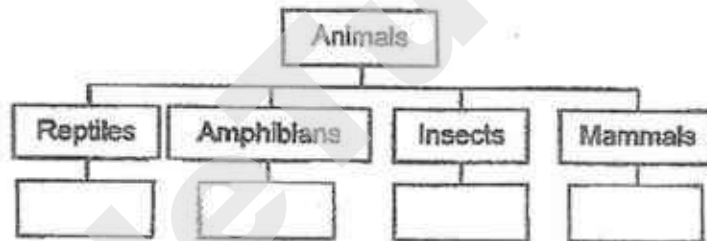

- (ii) Based on the information from the table and chart, give an example of an animal that has the same characteristics as Animal P. [1]

(Go on to the next page)

SCORE	2
-------	---

16. The diagrams below show the human digestive system.

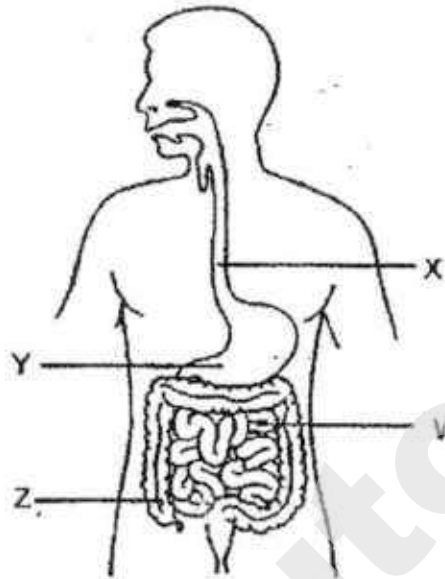

- (a) Name parts W and X. [1]

W: _____

X: _____

- (b) What happens to the food at part Y? [1]

- (c) Where does digestion start and end in the digestive system? [1]

(Go on to the next page)

SCORE	
	3

17. The diagrams below shows the life cycles of two different organisms, A and B.

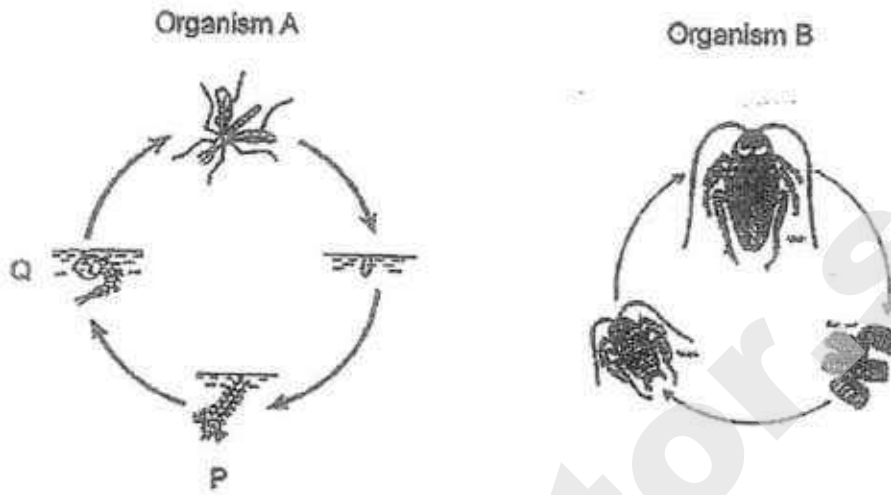

(a) Identify the two stages, P and Q, in the life cycle of Organism A. [1]

P: _____

Q: _____

(b) State a difference between the young and the adult of organism B. [1]

(c) State a similarity in the life cycles of the two organisms, A and B, shown above. [1]

(Go on to the next page)

SCORE	3
-------	---

18. Janice wanted to find out if the number of batteries connected to the coil of wire would affect the strength of an electromagnet. An iron bar becomes an electromagnet when it is placed in a coil of wire connected to batteries. She carried out her experiment using four arrangements, W, X, Y and Z.

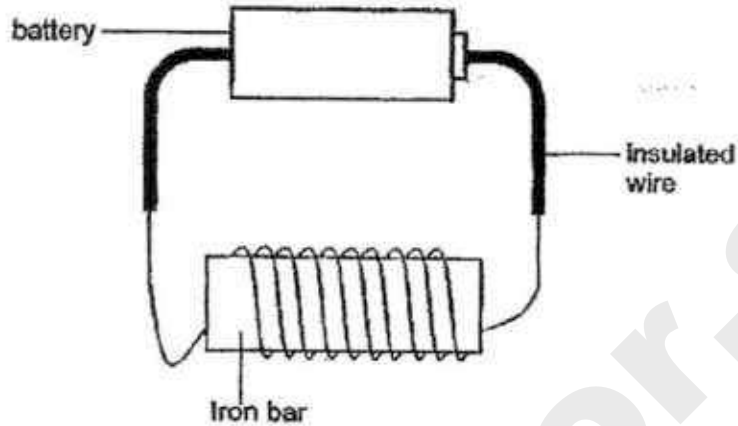

Arrangement	Number of batteries	Number of turns of coil of wire around iron bar
W	4	20
X	2	30
Y	3	30
Z	4	40

- (a) Which two arrangements should she set up to carry out her experiment? [1]

- (b) Janice placed the same number of identical paper clips below each electromagnet to test its strength. However, Janice observed that none of the paper clips was attracted to the electromagnets even when the batteries were working well. Explain why. [1]

- (c) Janice would also like to find out if the number of coils of wire around an electromagnet would affect the strength of the electromagnet.

Tick the variable(s) to be kept constant to ensure a fair test in this experiment. [1]

Number of batteries	<input type="checkbox"/>
Number of coils of wire	<input type="checkbox"/>
Size of iron bar	<input type="checkbox"/>

(Go on to the next page)

SCORE	<input type="checkbox"/>
	3

19. Mrs Lim wanted to warm up a bottle of cold milk for her baby to drink. She placed the bottle of cold milk in a basin of hot water.

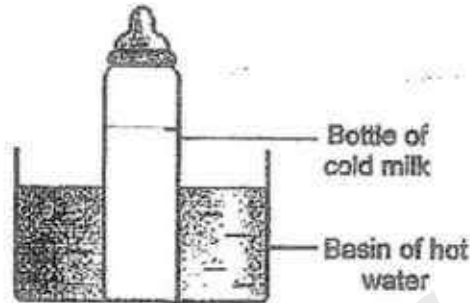

- (a) What happened to the temperature of the cold milk and the hot water after one minute? Explain your answer clearly. [2]

- (b) After Mrs Lim removed the bottle of milk from the basin of water, she left the basin of water on the table for 50 minutes. Draw a line graph to show the change in temperature of the hot water during the 50 minutes. [1]

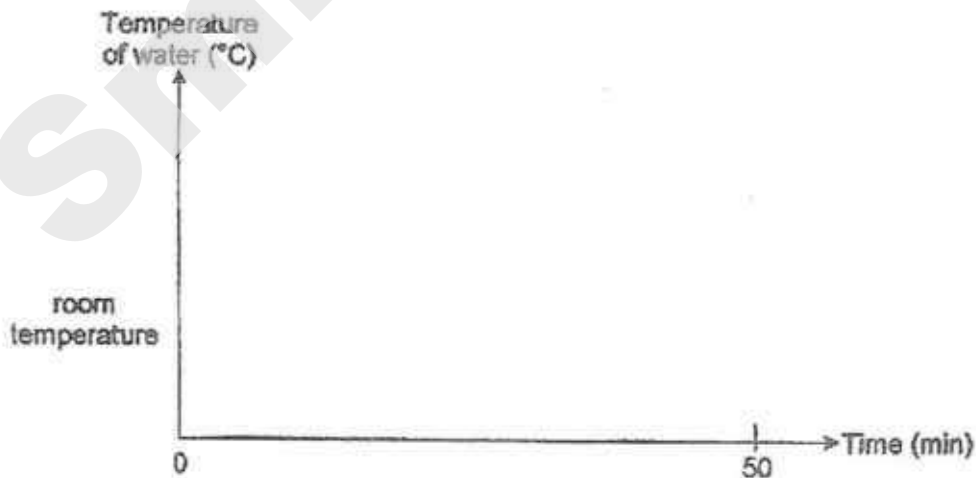

(Go on to the next page)

SCORE	3
-------	---

20. The diagram below shows a model of the human respiratory system.

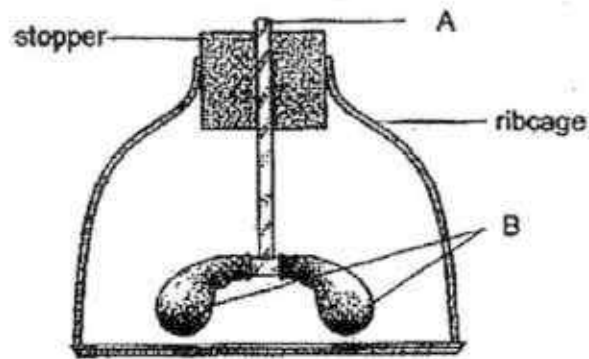

- (a) What do parts A and B represent in the human respiratory system? [1]

A: _____

B: _____

- (b) Explain the gaseous exchange that takes place in our lungs when we breathe in and out. [1]

- (c) What is the function of the windpipe? [1]

(Go on to the next page)

SCORE	3
-------	---

21. Sam jogged for 30 minutes in a park. He recorded his pulse rate before he started jogging to the moment he cooled down with a heart rate monitor. His pulse rate is shown in the graph below.

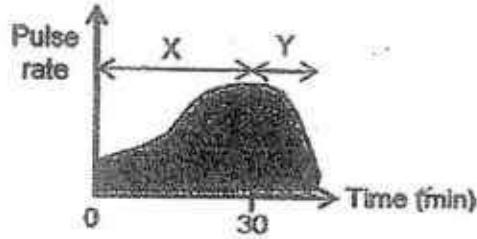

- (a)(i) Based on the graph above, describe how the pulse rate changes from the beginning of Period X to the end of Period Y in the graph. [1]

- (ii) Explain your answer for Period X in (a)(i). [1]

- (b) The heart muscles will contract and relax continuously. What is the purpose of this action? [1]

End of Booklet B

SCORE	3
-------	---

EXAM PAPER 2017 (P5)

SCHOOL : ACS

SUBJECT : SCIENCE

TERM : CA1

Q1	Q2	Q3	Q4	Q5	Q6	Q7	Q8	Q9	Q10
3	2	4	1	2	3	2	2	1	1
Q11	Q12	Q13	Q14						
1	3	2	2						

15)a)i)C , D

ii)A reproduces from seeds while B does not reproduce by seeds.

b)i)R , Q , S , P

ii)Rabbit

16)a)W: small intestine X: gullet

b)To food will be mixed with digested juices.

c)Digestion starts from the mouth and ends in the small intestine.

17)a)P : larva Q; pupa

b)The young cannot fly while the adult can fly.

c)Both have egg stage.

18)a)X and Y.

b)The paper clips were not made of magnetic materials.

c)Number of batteries

Size of iron bar

19)a)The temperature of the cold milk will increase while the temperature of the water will decrease. The cold milk had gained heat from the hot water and the hot water and lost heat from the cold milk.



20)a)A : Windpipe B : Lungs

b)When we breath in the air, oxygen will be absorbed by the lungs, carbon dioxide and water vapour will be given out.

c)To transport air from mouth to lungs or lungs to mouth.

21)a)i)When he jogged the heart rate will increase and when he cooled down, the heart rate will decrease.

ii)When we run, our body will use up more blood, oxygen and digested food, therefore the heart needs to pump faster in order for the body to have sufficient blood.

b)The purpose is to pump blood to all parts of the body.

CONTINUAL ASSESSMENT

1

2017

PRIMARY FIVE**SCIENCE****Booklet A**

Name: _____ ()

Class: Primary 5 - _____

Date: 2 March 2017

Parent's Signature: _____

11 questions**22 marks****Total Time for Booklets A and B: 45 minutes****INSTRUCTIONS TO CANDIDATES**

Do not turn over this page until you are told to do so.

Follow all instructions carefully.

Answer all questions.

Shade your answers in the Optical Answer Sheet (OAS) provided.

This booklet consists of 6 printed pages, excluding cover page.

Booklet A (11 × 2 marks)

For each question from 1 to 11, four options are given. One of them is the correct answer. Make your choice (1, 2, 3 or 4). Shade your answer on the Optical Answer Sheet.

(22 marks)

1 The diagram below shows two flowers from the same plant.

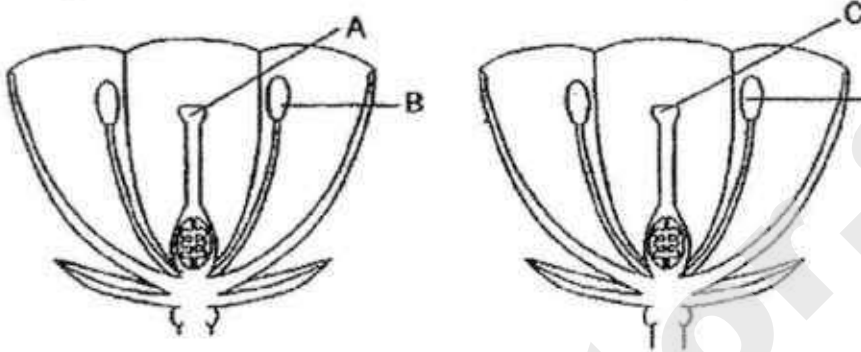

Pollination between these two flowers occurs when pollen grains are transferred from _____.

- (1) A to C
- (2) A to D
- (3) B to C
- (4) B to D

2 Arrange the following processes in the correct sequence.

- A pollination
- B fertilisation
- C germination
- D seed dispersal

- (1) A → B → C → D
- (2) A → B → D → C
- (3) B → C → A → D
- (4) B → D → C → A

- 3 Which part of the flower, if removed, would prevent the flower from forming a fruit?

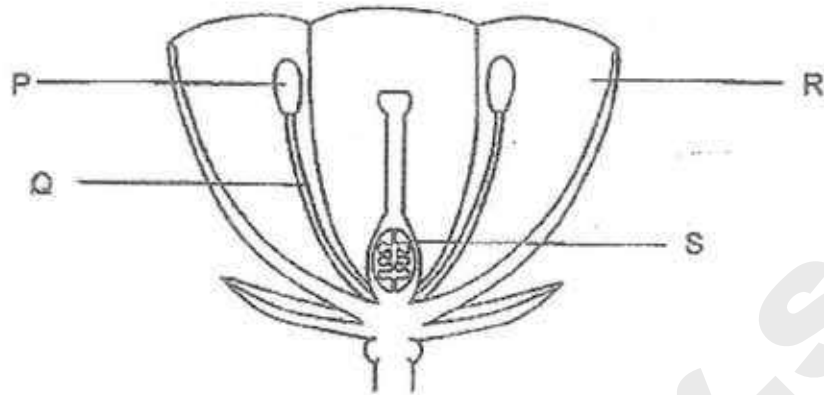

- (1) P
- (2) Q
- (3) R
- (4) S

- 4 Fanny dropped two fruit, X and Y, from the same height and measured the time taken for each fruit to reach the ground.



fruit X



fruit Y

Which of the following set of readings is most likely correct?

	Time taken for fruit X to reach the ground (s)	Time taken for fruit Y to reach the ground (s)
(1)	3.3	5.3
(2)	4.5	5.5
(3)	5.3	3.3
(4)	4.5	4.5

5. Seeds W, X, Y and Z from a plant are placed under the conditions as shown in the table below. A tick (✓) in the box represents the presence of the condition for the seed.

seed	Conditions			
	air	water	light	temperature (°C)
W	✓	✓		35
X		✓	✓	35
Y	✓			35
Z	✓		✓	35

Which seed, W, X, Y or Z, would most likely germinate?

- (1) W
 (2) X
 (3) Y
 (4) Z
6. The table below shows the different parts of the reproductive system of a plant and human.

Parts of the reproductive system	
Plant	Human
X	testis
male reproductive cell in the pollen grain	Y
ovary	ovary
female reproductive cell in the ovule	Z

Which of the following correctly represents X, Y and Z?

	X	Y	Z
(1)	anther	penis	ovule
(2)	filament	penis	egg
(3)	filament	sperm	ovule
(4)	anther	sperm	egg

7 Study the diagram below.

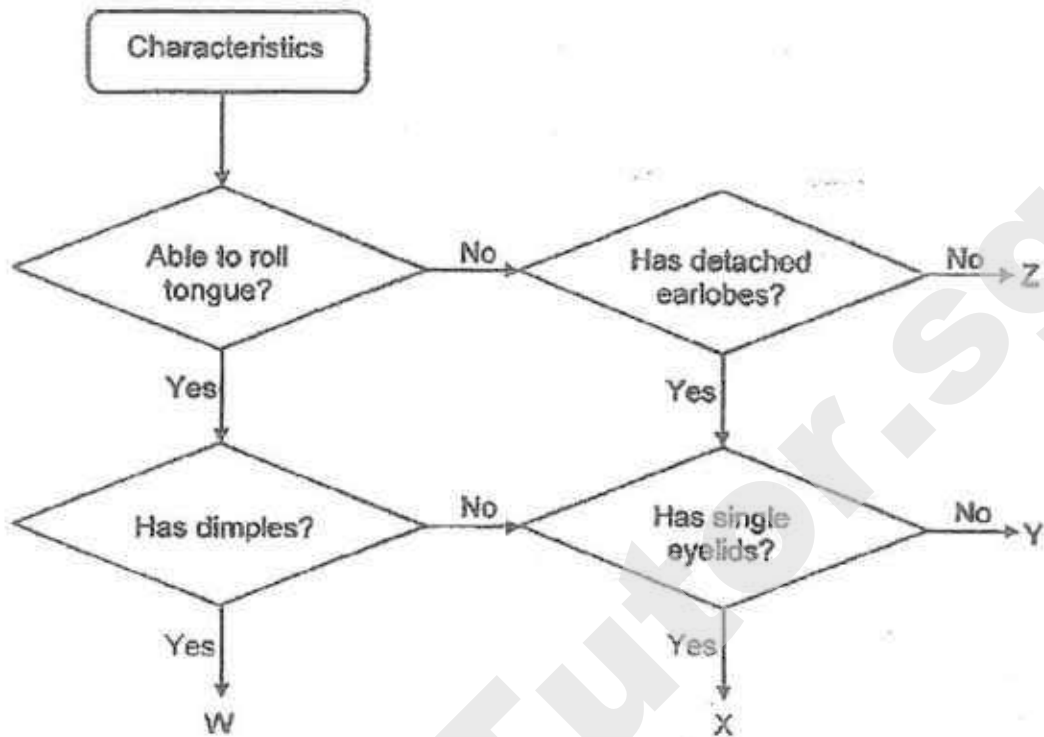

Cathy is unable to roll her tongue, has detached earlobes but does not have double eyelids. Which letter, W, X, Y or Z, best represents Cathy?

- (1) W
- (2) X
- (3) Y
- (4) Z

- 8 The diagram below shows the male and female reproductive systems.

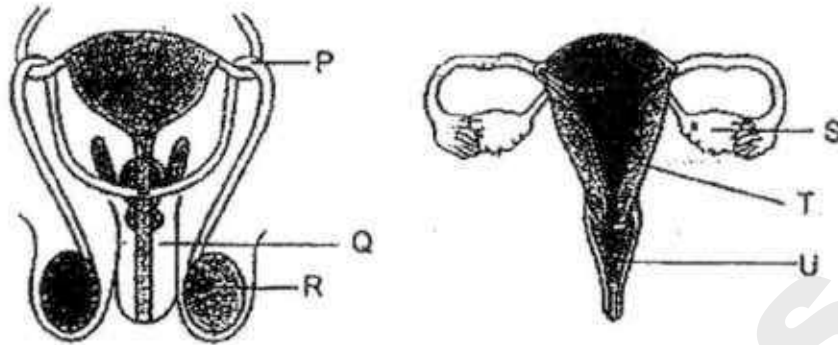

Which of the following is correct?

	Produces sperm cell	Produces egg cell	Place where the fertilised egg develops
(1)	P	T	U
(2)	R	S	T
(3)	S	R	U
(4)	Q	S	T

- 9 The diagram below shows the changes in the state of water.

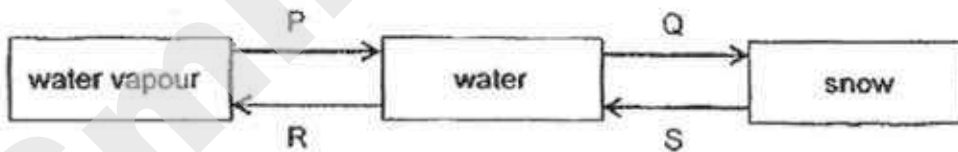

What do P, Q, R and S represent?

	P	Q	R	S
(1)	condensation	freezing	evaporation	melting
(2)	evaporation	melting	freezing	condensation
(3)	condensation	freezing	melting	evaporation
(4)	evaporation	melling	evaporation	freezing

- 10 Which one of the following correctly shows heat gain or loss for the processes?

	Process	Heat Involved
(1)	boiling	heat loss
(2)	melting	heat loss
(3)	condensation	heat gain
(4)	evaporation	heat gain

- 11 A beaker of ice was heated to 100°C before it was left to cool. The changes in temperature are shown in the graph below.

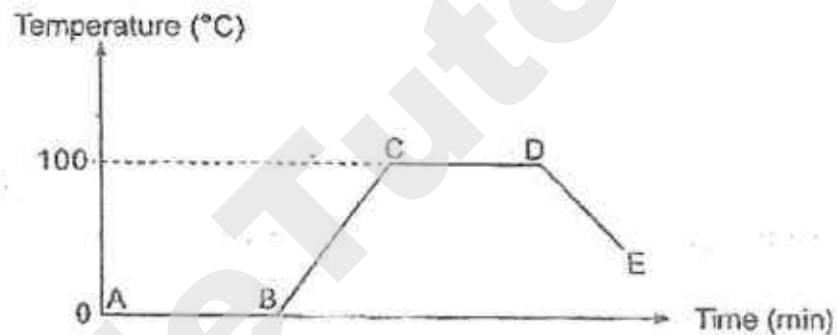

Based on the graph above, which one of the following is correct?

	Melting	Boiling
(1)	AB	CD
(2)	AB	BC
(3)	DE	CD
(4)	DE	BC

End of Booklet A

**CONTINUAL ASSESSMENT
1
2017
PRIMARY FIVE**

SCIENCE

Booklet B

Name: _____ ()

Class: Primary 5 - _____

Date: 2 March 2017

Parent's Signature: _____

6 questions

18 marks

Booklet A	22
Booklet B	18
Total	40

Total Time for Booklets A and B: 45 minutes

INSTRUCTIONS TO CANDIDATES

Do not turn over this page until you are told to do so.

Follow all instructions carefully.

Answer all questions.

Write your answers in this booklet.

This booklet consists of 6 printed pages, excluding cover page.

Booklet B (18 marks)

For questions 12 to 17, write your answers in this booklet.

The number of marks available is shown in brackets [] at the end of each question or part question. (18 marks)

- 12 Yusri wanted to find out if overcrowding affects the growth of plants. The diagram below shows the seeds in pots X and Y before germination has taken place.

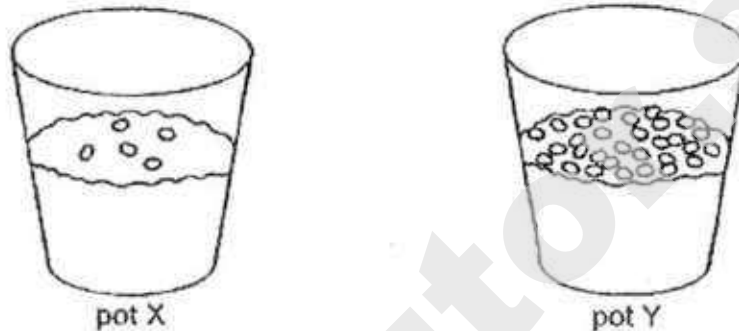

- (a) The table below shows the variables changed or kept constant throughout the experiment. Write 'changed' or 'kept constant' in the boxes provided. [1]

Variables		
(i)	Amount of soil used	
(ii)	Amount of water used	
(iii)	Number of seeds used	

One week later, Yusri observed and concluded that overcrowding affects the growth of the plants.

- (b) Explain why it is important for seeds to be dispersed far away from the parent plant. [2]

(Go on to the next page)

SCORE	3
-------	---

13 Study the dispersal of seeds by plants X and Y in the diagram below.

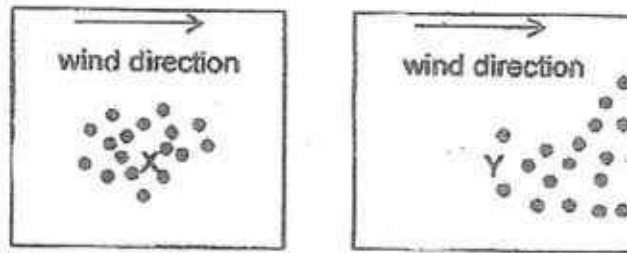

(a) Based on the diagram above, state the dispersal methods for the seeds of plants X and Y. [1]

(i) Plant X : Dispersed by _____

(ii) Plant Y : Dispersed by _____

The diagram below shows the fruit of a plant.



(b) State the dispersal method for the fruit above. [1]

(c) Explain your answer in (b) [1]

(Go on to the next page)

SCORE	3
-------	---

14 The diagram below shows the family tree of James and his two siblings.

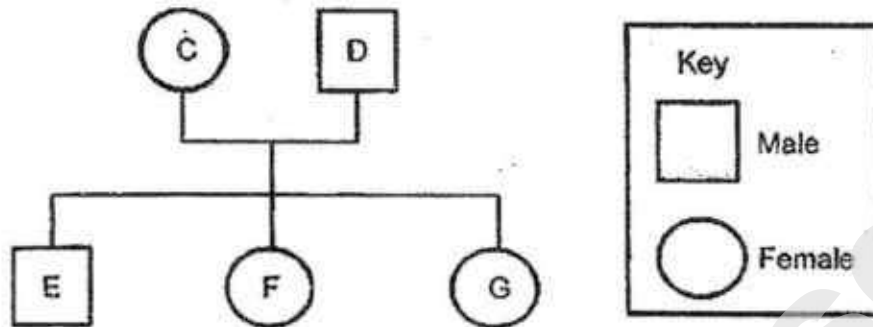

The table below shows the observable characteristics that are passed on to the members of his family. A tick (✓) in the box denotes the presence of the characteristics in that family member.

Family members	Characteristics		
	Attached earlobes	Single eyelids	Straight thumb
C		✓	
D	✓		✓
E	✓	✓	✓
F		✓	✓
G		✓	

(a) Based on the family tree, which letter, C, D, E, F or G, represents him? State the observable characteristic(s) which he has inherited from his father. [1]

(b) Based on the table above, write 'T' if the statement is true and 'F' if the statement is false in the boxes provided. [1]

(i)	The single eyelids characteristic is passed on only to females.	
(ii)	The attached earlobes characteristic is passed on only to males.	

(c) James told his siblings that he has inherited his interest in reading from his father. Do you agree with him? Why? [1]

(Go on to the next page)

SCORE	3
-------	---

15 Study the diagrams below.

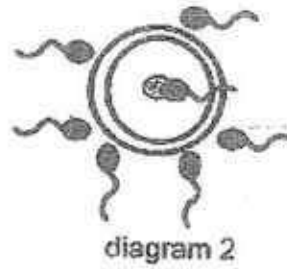
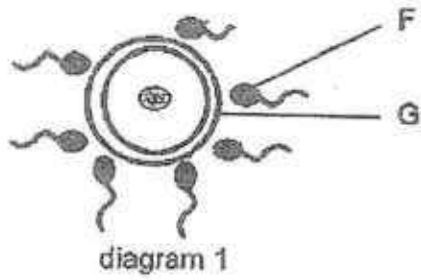

(a) Identify F and G in diagram 1.

[1]

F: _____

G: _____

(b) Name the process and state how it takes place in diagram 2.

[1]

(c) What happens after the process in diagram 2?

[1]

(Go on to the next page)

SCORE	3
-------	---

- 16 Lydia took out a cup of ice water from the refrigerator and left it on the table in a room of 27°C as shown in the diagram below.

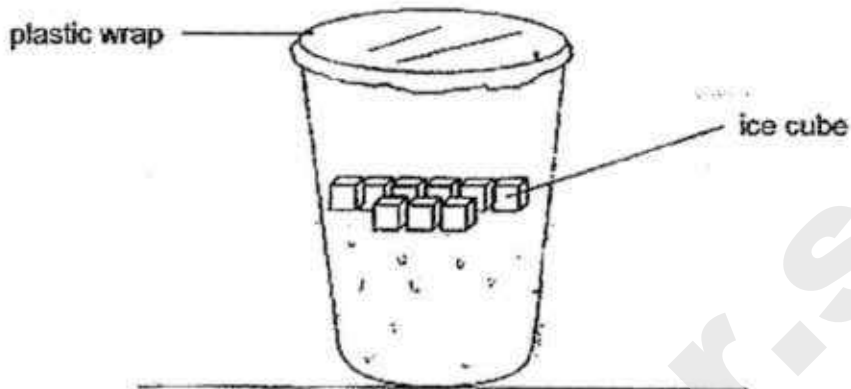

- (a) Draw water droplets on the diagram above to show where the droplets would be formed. [1]
- (b) What is the temperature of the ice cube when it is melting? [1]

(Go on to the next page)

SCORE	2
-------	---

- 17 Osher boiled a kettle of water and placed a frying pan near the sprout of the kettle as shown in the diagram below.

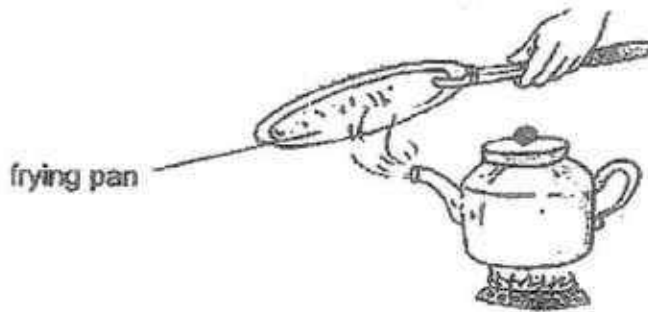

- (a) Name the substance formed on the frying pan. [1]

- (b) If the kettle of water is boiled for some time, what would happen to the volume of the water in the kettle? [1]

- (c) What is the temperature of the water in the kettle when it is boiling? [1]

- (d) Write the change of state when water boils. [1]

From _____ state to _____ state

End of Booklet B

SCORE	4
-------	---

YEAR : 2017
SCHOOL : CATHOLIC HIGH SCHOOL
LEVEL : P5
SUBJECT : SCIENCE
TERM : CA1

Booklet A

Q1	3	Q2	2	Q3	4	Q4	3	Q5	1
Q6	4	Q7	2	Q8	2	Q9	1	Q10	4
Q11	1								

Booklet B

Q12 (a)

Amount of soil used	Keep constant
Amount of water used	Keep constant
Number of seeds used	Changed

(b) Overcrowding will lead to competition of light, water, nutrients and space, so if they are not dispersed far away from the parent plant, the young plants will not grow healthily.

Q13 (a) Plant X: Dispersed by explosive action
Plant Y: Dispersed by wind

(b) Water dispersal.

(c) The fibrous husk traps small pockets of air which allows the fruit to float.

Q14 (a) E is James. He inherited attached earlobes and a straight thumb from his father.

(b)

The single eyelids characteristics is passed on only to females.	False
The attached earlobes characteristics is passed on only to males.	True

(c) No. Reading is not a characteristic that can be inherited from the parent.

Q15 (a) F : Sperm cell
G : Egg cell

(b) Fertilisation. The male reproductive cell fuses with the female reproductive.

(c) The egg will be fertilised and starts to develop into a baby.

Q16 (a)

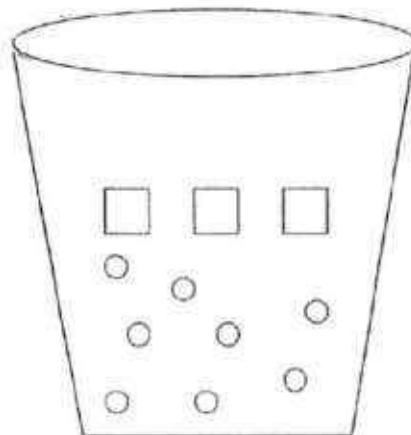

(b) 0°C

- Q17 (a) Water droplets.
(b) The volume of water in the kettle will decrease
(c) 100°C
(d) liquid, solid

SmileTutor.sg

CONTINUAL ASSESSMENT 1 2017

PRIMARY FIVE
SCIENCE

Name : _____ ()
Class : Primary 5 / ____
Date : 24 February 2017

MARKS	
Sect A:	/ 56
Sect B:	/ 44
Total :	/ 100

Parent's Signature

Section A: (28 x 2 marks = 56 marks)

For each question from 1 to 28, four options are given. One of them is the correct answer. Make your choice (1, 2, 3 or 4). Shade the correct oval (1, 2, 3 or 4) on the Optical Answer Sheet.

- 1 The diagram below shows how an organ can be formed from a basic unit of life represented by W.



Which of the following correctly represents the basic unit of life?

- (1) Cell
- (2) Cell wall
- (3) Cytoplasm
- (4) Cell membrane

2. A cell and a plant are shown in the diagrams below.

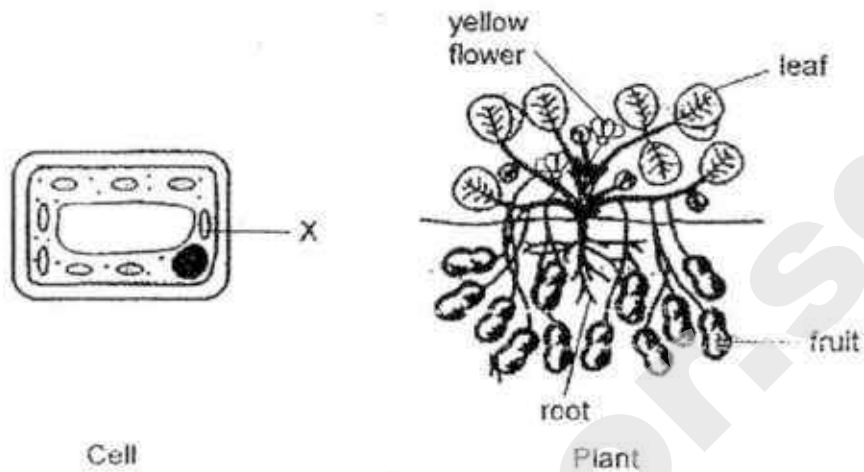

Which part of the plant can part X be found?

- (1) fruit
 - (2) leaf
 - (3) root
 - (4) yellow flower
3. The diagram below shows a group of cells.

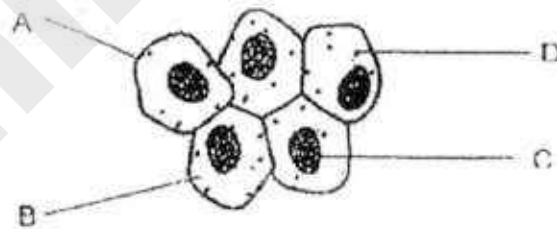

Which part of the cell contains genetic information that is passed on from one generation to the next?

- (1) A
- (2) B
- (3) C
- (4) D

4. The diagram below shows the physical characteristics of two parent plants and their offsprings.

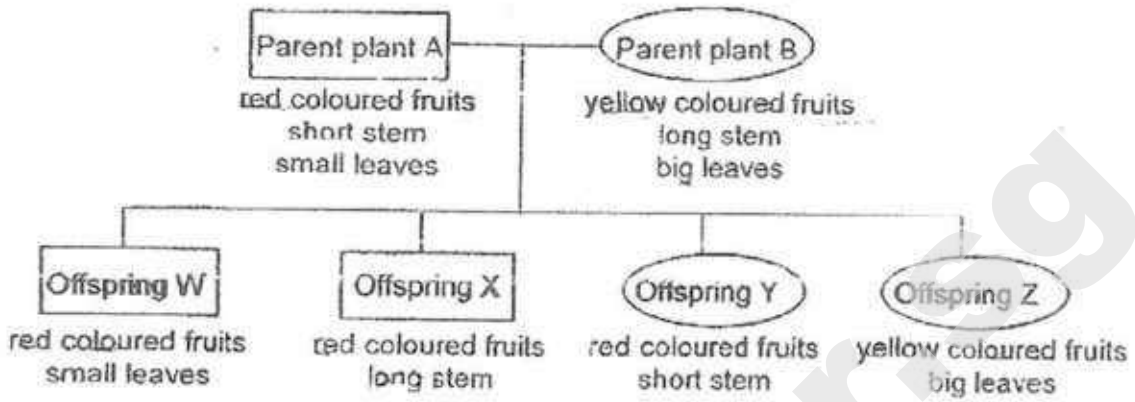

Which offspring inherited only one characteristic from each parent?

- (1) Offspring W
 - (2) Offspring X
 - (3) Offspring Y
 - (4) Offspring Z
5. The diagram below shows a plant.

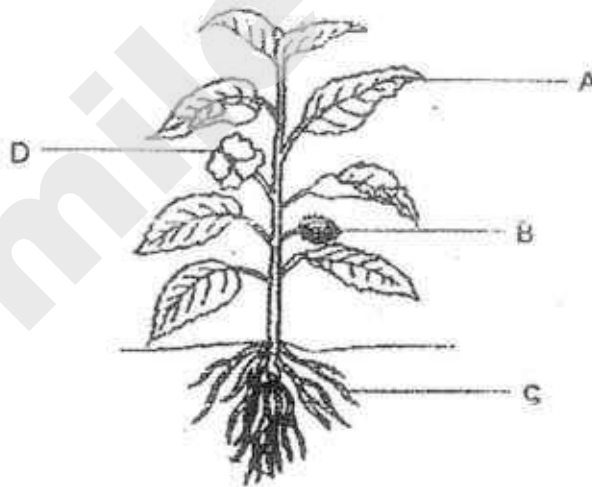

Which reproductive part(s) help(s) the plant to reproduce?

- (1) B only
- (2) A and C only
- (3) B and D only
- (4) A, B and C only

6. The diagram below shows the development of seeds to seedlings.



Which of the following are needed by the seeds to develop into seedlings?

- A soil
 - B water
 - C oxygen
 - D warmth
- (1) A and D only
(2) B and C only
(3) B, C and D only
(4) A, B, C and D
7. The Jay bird collects nuts and buries them in the ground to eat later. Sometimes, the Jay bird does not go back for the nuts.

What will most likely happen to the buried nuts?

- (1) The buried nuts will be fertilised
- (2) The buried nuts will be pollinated.
- (3) The buried nuts will develop new fruit.
- (4) The buried nuts will develop into seedlings.

8. The diagram below shows a fern growing on a tree.

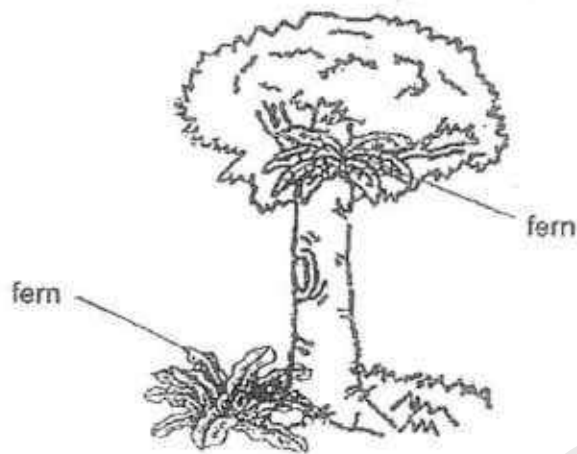

How did the fern grow on the tree?

- (1) The wind carried the fern to the tree.
 - (2) The insects carried the spores to the tree.
 - (3) The wind carried the seeds from the fern to the tree.
 - (4) The wind carried the spores from the fern to the tree.
9. The diagram below shows the changes in the state of water.

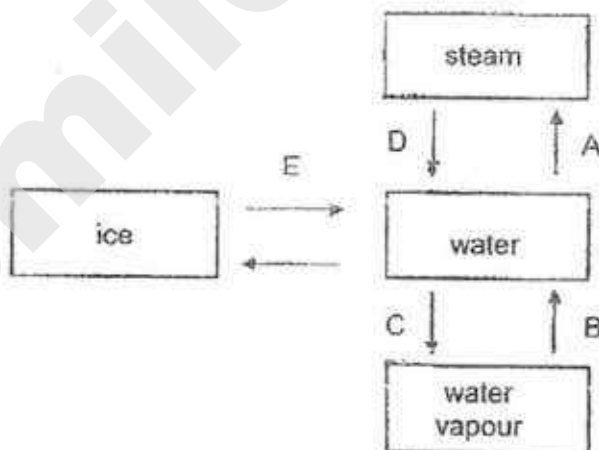

Which of the following processes, A, B, C, D, E or F, will heat loss take place?

- (1) A, C and E only
- (2) B, D and F only
- (3) A, B, D and F only
- (4) B, C, E and F only

10. Which activities are a good way of saving water?

- A Take a shower instead of a bath
- B Put bigger and more pebbles into fish tank.
- C Collect water from washing vegetables to flush the toilet.
- D Use water hose to wash car instead of using a pail of water.

- (1) A and D only
- (2) B and D only
- (3) A, B and C only
- (4) A, B, C and D

11. The diagram below shows two beakers, with the same amount of water at different temperature, placed in the same room.

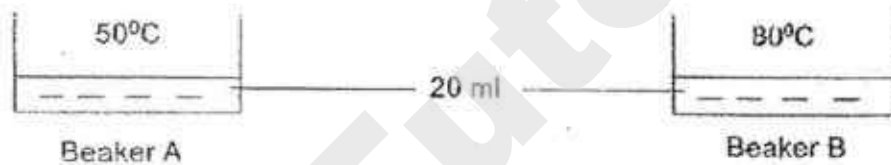

Which one of the following statements is correct?

- (1) Both beakers of water will reach room temperature at the same time.
- (2) The amount of heat in the water in beaker A and beaker B is the same.
- (3) The amount of heat in the water in beaker A is greater than in beaker B.
- (4) The amount of heat in the water in beaker B is greater than in beaker A.

12. Study the graphs below. Graph A shows the relationship between the number of substance X and light intensity. Graph B shows the relationship between the number of substance X and the mass of plant.

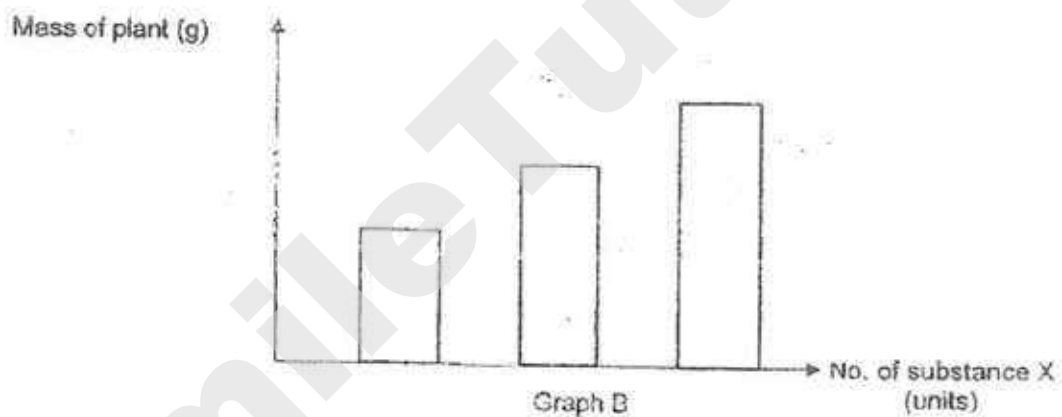
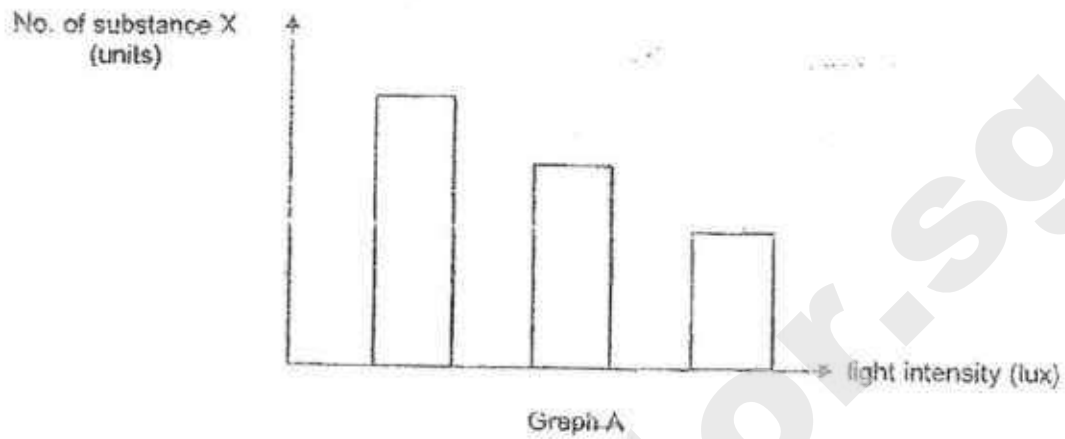

Based on the graphs, which of the following statements is/are correct?

- A Strong light intensities can reduce the number of substance X.
- B The mass of the plant will decrease when the light intensity decrease
- C As the number of substance X increases, the mass of the plant increases.

- (1) A only
- (2) A and C only
- (3) B and C only
- (4) A, B and C

13. Which one of the following shows the correct comparison between a plant cell and an animal cell?

	Animal cell	Plant cell
(1)	It has more than one nucleus	It has one nucleus
(2)	It does not have chloroplast	It has chloroplast
(3)	It has a cell wall but cannot maintain a regular shape	It has a cell wall to maintain a regular shape
(4)	It has cytoplasm that is surrounded by cell membrane	It has cytoplasm that is surrounded by cell wall

14. The diagram below shows the pattern of seed dispersal of four types of trees.

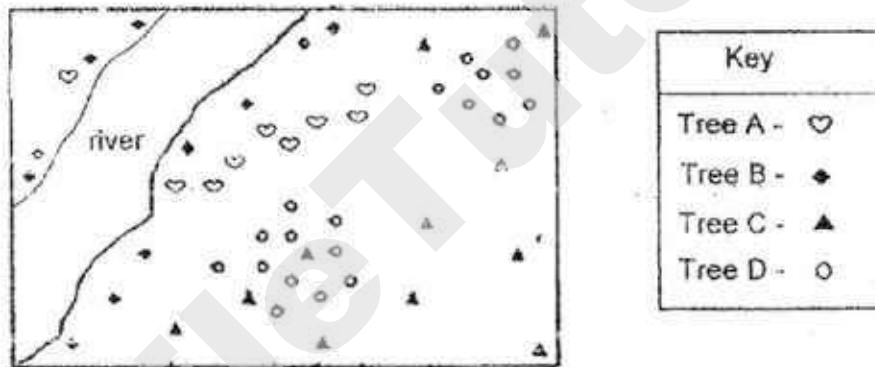

The diagram below shows the fruit of one of the trees.

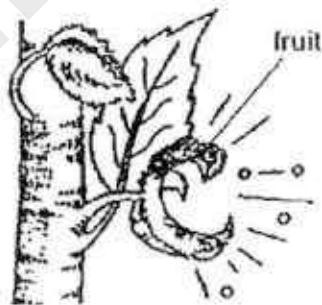

Based on the diagrams, which symbol represents the tree of the fruit shown above?

- (1) ♡
- (2) ◆
- (3) ▲
- (4) ○

15. An experiment is set up to find out how different types of liquid will affect the germination of seeds from the same plant.

The diagram below shows the set-ups of the experiment.

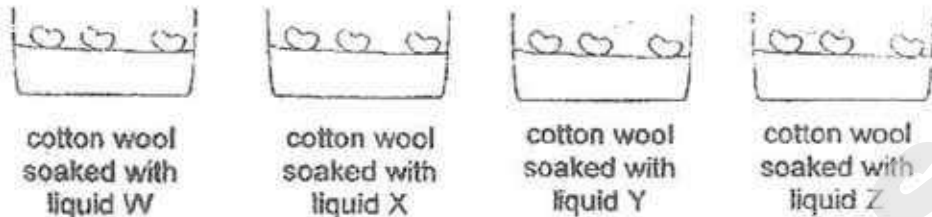

Which of the statement(s) correctly explain(s) why there must be more than one seed in each set-up?

- A To grow more plants for the experiment.
- B To absorb the liquid faster so that the seeds germinate faster.
- C To ensure that there are still seeds left to carry out the experiment even if some died.

- (1) C only
- (2) A and B only
- (3) B and C only
- (4) A, B and C

16. The table below describes the appearance of flowers from three different types of plants.

Flower	Brightly coloured petals	Gives off a sweet scent	Anthers and stigma stick out of the flower
X	No	Yes	No
Y	No	No	Yes
Z	Yes	No	No

Based on the information in the table, which of the flowers is/are most likely pollinated by insects?

- (1) Z only
- (2) X and Y only
- (3) X and Z only
- (4) X, Y and Z

17. The diagram below shows the young of an organism during one of the stages in its life cycle.

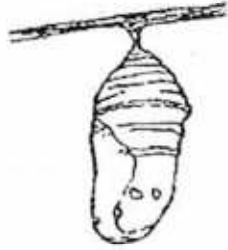

Which one of the following will the young above look like when it becomes an adult?

(1)



caterpillar

(2)

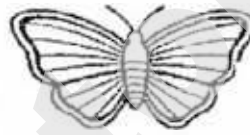

butterfly

(3)

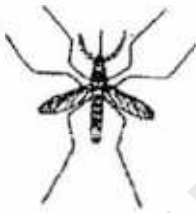

mosquito

(4)



cockroach

18. An experiment was conducted and the graph below shows the temperature change of some ice cubes.

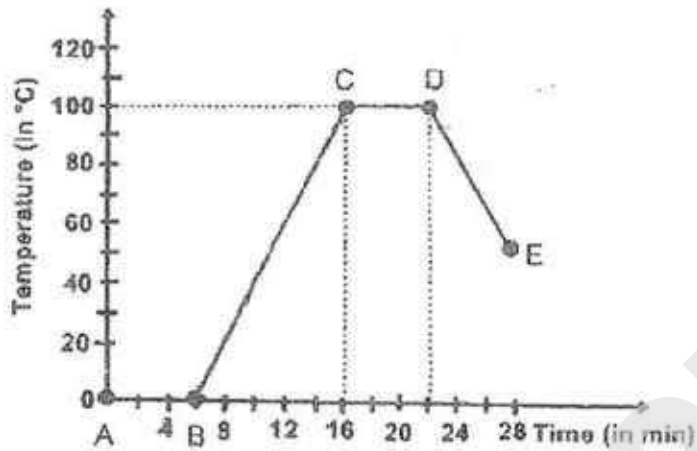

Based on the graph, which of the following statements is/are correct?

- A The water lost heat from part D to E.
 - B There was a change of state from part A to B and part C to D only.
 - C There was no heat gain from part A to B, but there was heat gain from part B to C.
- (1) A only
(2) A and C only
(3) B and C only
(4) A, B, and C

19. The diagram below shows a distiller.

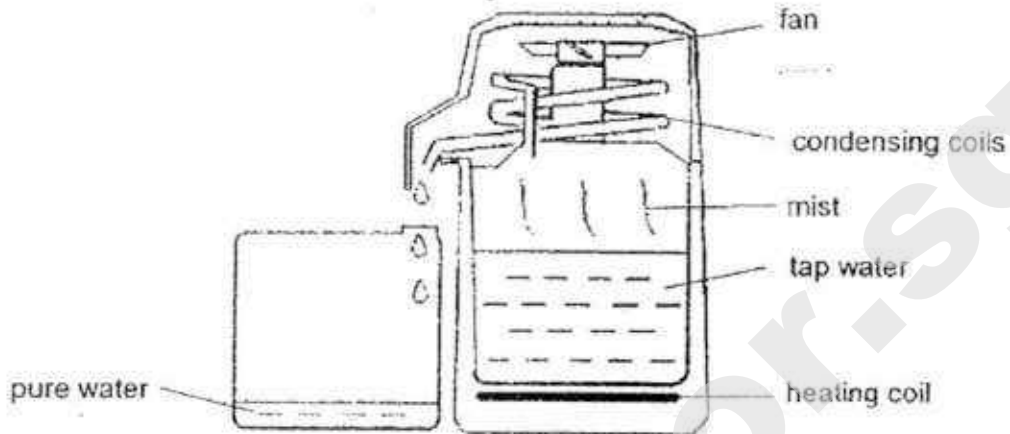

A distiller is used to separate substances found in tap water so as to get pure water for drinking. First, the tap water has to be heated by the heating coil.

Which one of the following statements shows the correct functions of the different parts of the distiller?

	Heating coil	Condensing coils	Fan
(1)	To boil the water to get water vapour	To provide a cool surface for the water vapour	To heat up the condensing coils
(2)	To boil the water to get water vapour	To provide a warm surface for the water vapour	To cool the condensing coils
(3)	To boil the water to get steam	To provide a warm surface for the steam	To heat up the condensing coils
(4)	To boil the water to get steam	To provide a cool surface for the steam	To cool the condensing coils

20. Sam used the following set-up to find the volume of the ball.

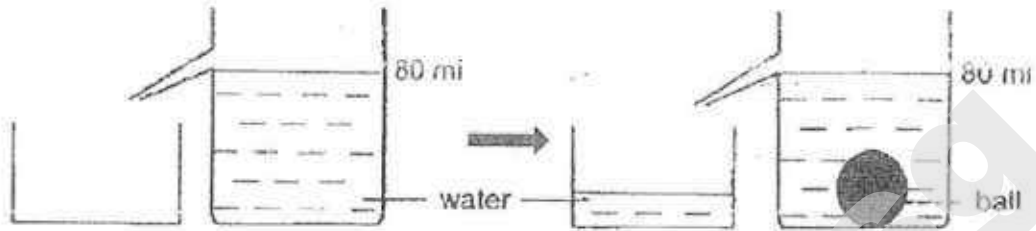

What property/ properties of water enable(s) him to find the volume of the ball?

- A Water has a definite mass
- B Water has a definite shape
- C Water has a definite volume

- (1) B only
- (2) C only
- (3) A and C only
- (4) A, B and C

21. The diagram below shows that some identical wooden blocks were being put into a tray.

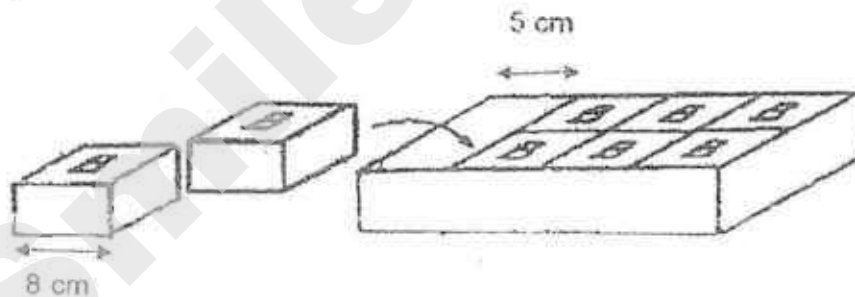

Which of the following statements correctly explain(s) why the remaining two wooden blocks were unable to fit into the tray?

- A The blocks have fixed shape.
- B The blocks have fixed volume.
- C The blocks cannot be compressed.

- (1) A only
- (2) A and B only
- (3) B and C only
- (4) A, B and C

22. The diagrams below show different set-ups.

A

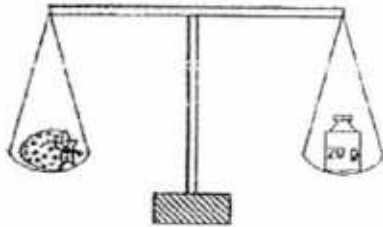

B

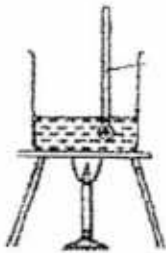

C

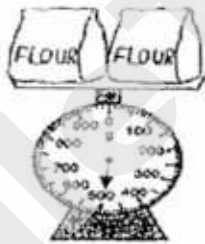

Which of the set-up(s) can be used to measure mass?

- (1) B only
- (2) C only
- (3) A and B only
- (4) A and C only

23. Study the diagram below.

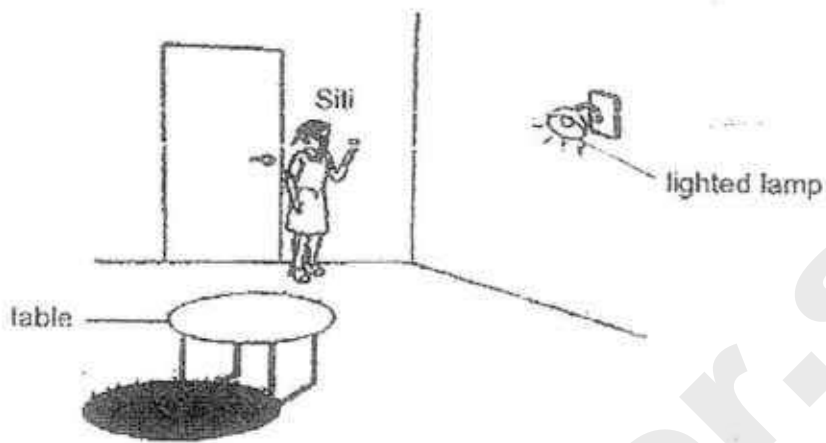

Which one of the following statements correctly explains why Siti was able to see the table in the room?

- (1) Light from the lamp falls onto the table.
- (2) Light from the lamp shines into Siti's eyes.
- (3) Light from the lamp was reflected from the table to Siti's eyes.
- (4) Light from the lamp was reflected from Siti's eyes onto the table.

24. The diagram below shows a torch shining on a circular metal disc.

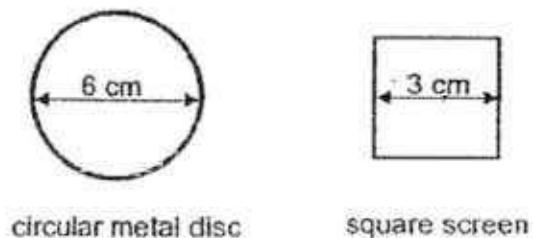

The circular disc and the square screen are hung from a board to suspend them in the air.

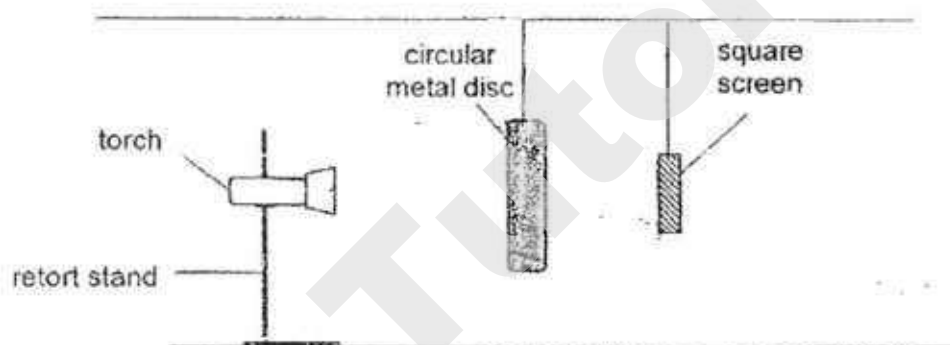

Which one of the following shadows will be shown on the screen?

- (1)
- (2)
- (3)
- (4)

25. An experiment was conducted to find out how the size of the shadow is affected by the distance between the object and the screen.

The diagram below shows the set-up of the experiment.

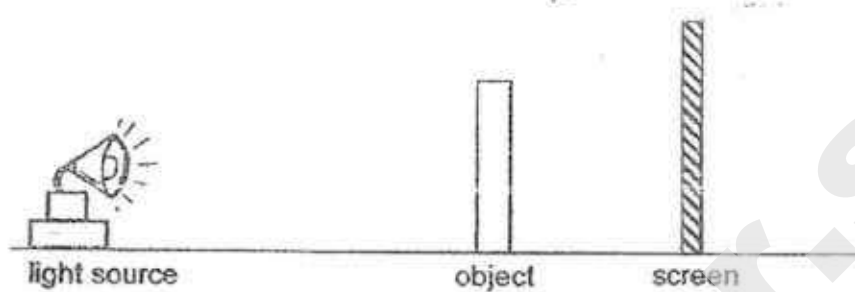

How should the experiment be carried out in order to collect data?

- (1) To use glass for the screen.
- (2) To move the screen away from the object.
- (3) To move the light source nearer to the object.
- (4) To exchange the positions of the screen and the object.

26. An experiment is set up as shown below.

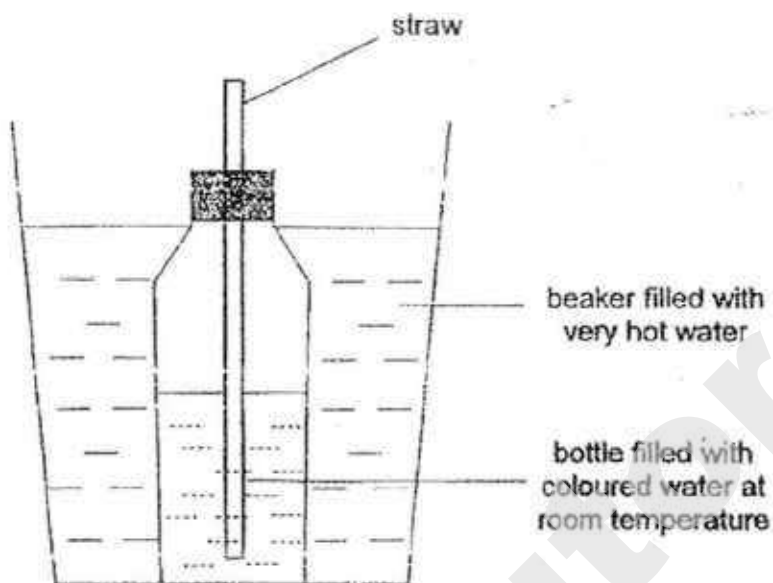

When the bottle was put into the beaker of hot water, water started sprouting out of the straw. After a while, the water stopped sprouting out.

Which one of the following statements correctly explains why the water eventually stopped sprouting out from the straw?

- (1) All the water in the beaker had sprouted out of the straw.
- (2) The water in the bottle became colder than the water in the beaker.
- (3) All the water in the beaker evaporated immediately after the bottle was put in.
- (4) The water inside the beaker has reached the same temperature as the water in the bottle.

27. Four different metals, S, T, U and V, are used to make five rings as shown below. The dimension of the three big rings are the same. The dimension of the two small rings are identical to each other.

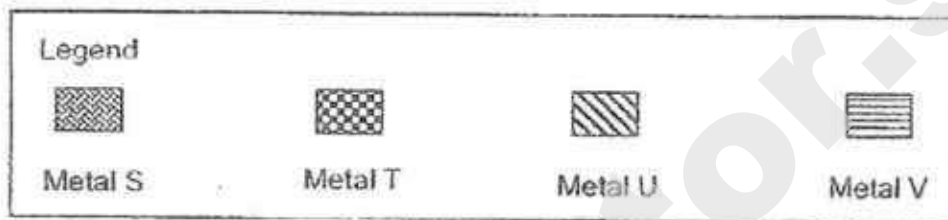
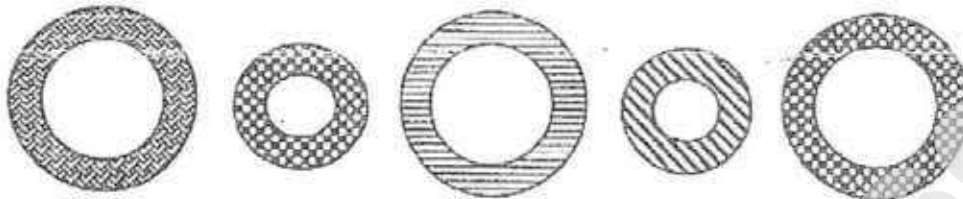

The five rings are fitted together to make three sets of ring, A, B and C.



At 28°C, the inner rings of each set could just fit into the outer ring and taken out with some effort. The sets of rings were heated to 40°C. The observations were recorded in the table below.

At 40°C		
Set A	Set B	Set C
Inner ring fell out of outer ring easily.	Inner ring could not be pulled out of outer ring even with great effort	Inner ring could just fit into outer ring and still pull out with some effort

Based on the above observations, which metal, S, T, U or V, expanded the most?

- (1) S
- (2) T
- (3) U
- (4) V

28. Two containers, one made of copper and the other of glass, were filled with the same amount of water. A glass tubing was then inserted into each container and the level of water in each tubing was adjusted to the same level as shown in the diagram below. The containers were then heated.

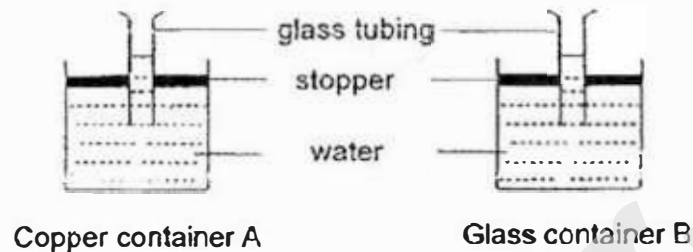

In which glass tubing will the water level rise first?

	Glass tubing in Container	Explanation
(1)	A	Copper is a better conductor of heat. The container expand faster upon heating causing the water level to rise faster.
(2)	A	Copper is a better conductor of heat and conduct heat faster to the water, causing water level to rise faster.
(3)	B	Glass is a poorer conductor of heat. The glass container contracted upon heating causing the water level to rise faster.
(4)	B	Glass is a poorer conductor of heat, causing the water in the container to absorb heat faster than the glass. so water level rises faster.

CONTINUAL ASSESSMENT 1
2017 PRIMARY FIVE
SCIENCE

MARKS
44

Name : _____ ()

Class : Primary 5 / _____

Section B: (44 marks)

Write your answers to questions 29 to 40.

The number of marks available is shown in brackets [] at the end of each question or part question.

29. The diagram below shows two similar set-ups of an experiment used to show the function of a specific cell part. The mass of the container without the funnel in each set-up is 750 g.

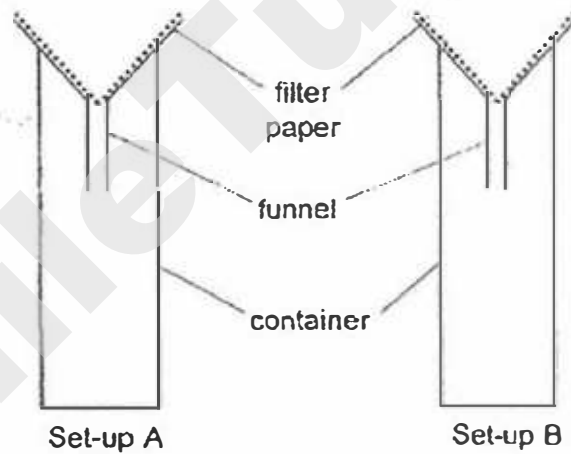

(Go on to the next page)

Particles W and X of the same mass are poured into the set-ups.
Particle W is poured into set-up A and particle X into set-up B.

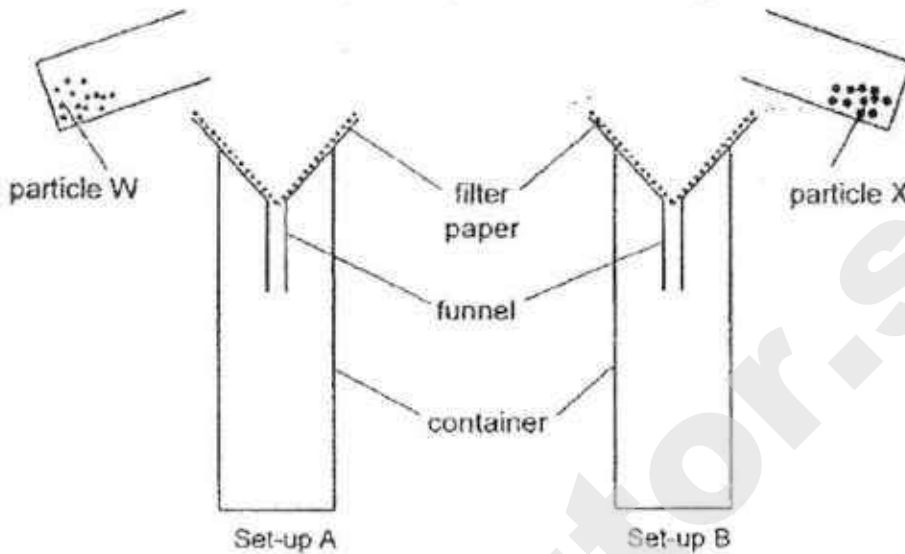

Then the mass of the container without the funnel for each set-up is taken and recorded in the table below.

	Mass of the container at the start of the experiment	Mass of the container at the end of the experiment
Set-up A	750 g	820 g
Set-up B	750 g	750 g

(a) Which part of the cell does the filter paper represent?

(b) What is the function of the cell part given in your answer in part (a)? [1]

(c) Give a reason why the mass of the container in set-up A changes at the end of the experiment. [1]

(Go on to the next page)

(d) Give a reason why the experiment should be conducted a few times? [1]

SmileTutor.sg

Score	4
-------	---

30. The diagram below shows a fruit tree covered in netting.

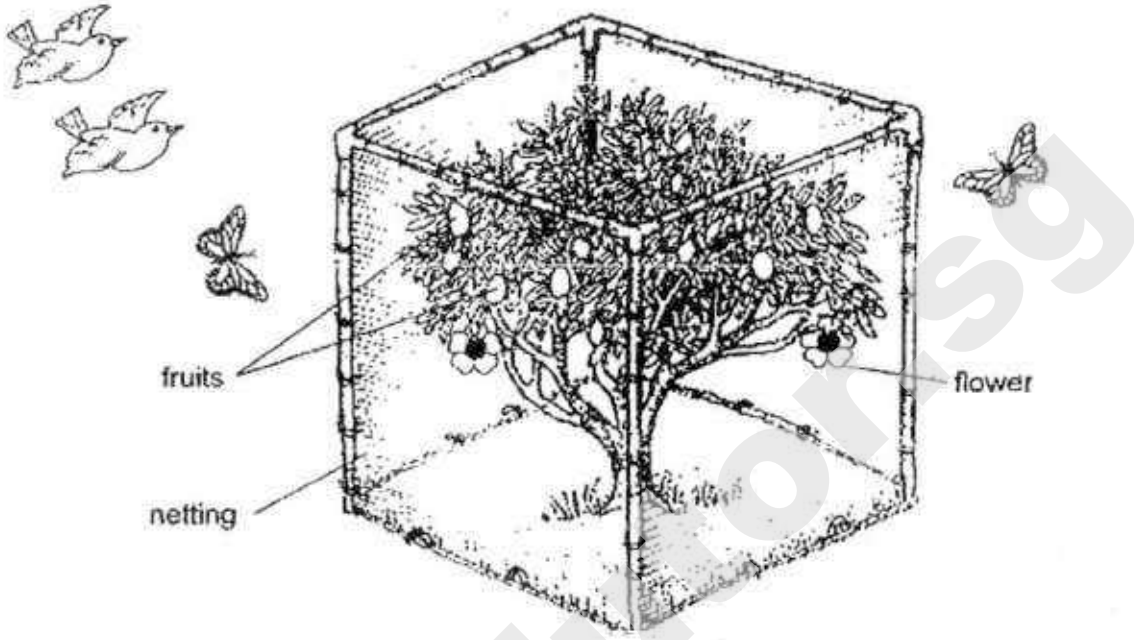

(a) Why must the tree be covered in netting to keep birds away from the fruit? [1]

(b) Give one characteristic of the fruit that allows it to attract the bird. [1]

(c) What is the disadvantage for the tree when it is covered in netting? [1]

Score	3
-------	---

31. The life cycles of the frog and mosquito are shown below.

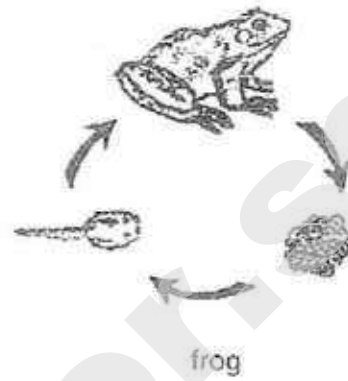
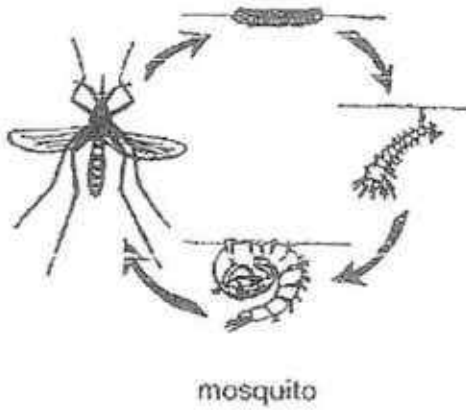

(a) State one difference between the life cycles of the frog and the mosquito. (Do not compare the organisms.) [1]

(b) State one similarity between the life cycles of the frog and the mosquito. [1]

(c) Give a reason why it is easier to catch the pupa of the mosquito than the tadpole of the frog. [1]

Score	3
-------	---

32. The diagram below shows the set-up that Sam used to conduct an experiment to find out how the presence of wind will affect the rate of evaporation.

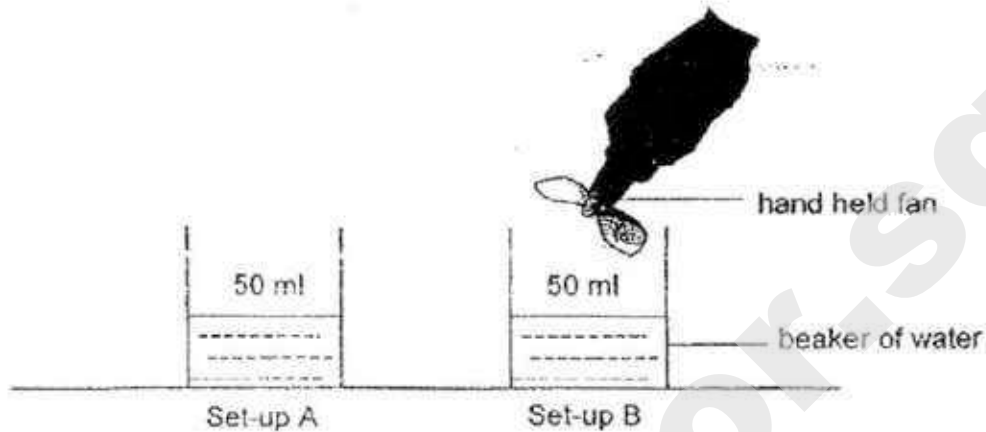

- (a) What is the purpose of set-up A? [1]

Using the same two beakers of water, Sam conducted a second experiment to investigate how the rate of evaporation of water will be affected. He left the set-ups undisturbed in the same room.

The diagram below shows the set-ups.

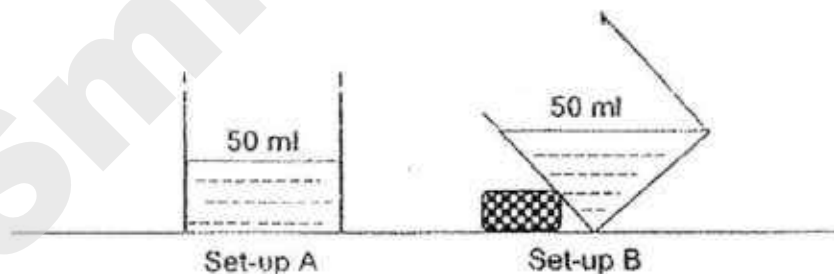

- (b) What is the aim of the experiment? [1]

(Go on to the next page)

(c) Write down two types of data or readings he could collect in order to come to a conclusion? [2]

SmileTutor.sg

Score	4
-------	---

33. The diagram below shows the shadow of the wooden stick when the torch was placed at position B.

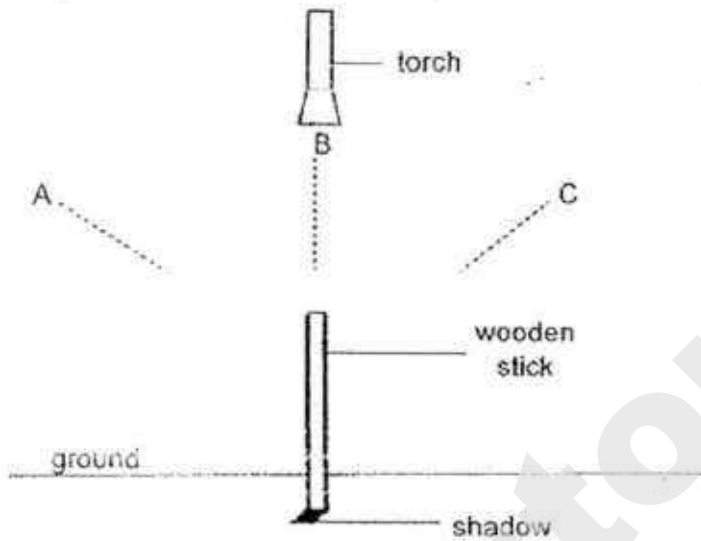

- (a) Put an "X" in the diagram above to show where the shadow will be if the torch is placed at position A. [1]
- (b) If the torch is at position A, what can be done using the torch to form a shorter shadow without moving it to positions B and C? [1]

- (c) The graph below shows the results for the above experiment. Complete the graph by writing the name of the variable changed and the name of the variable measured in the boxes. [2]

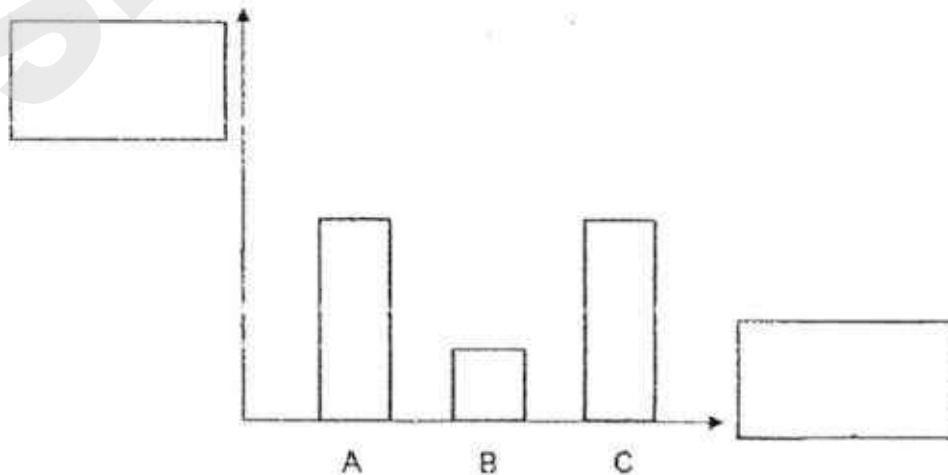

(Go on to the next page)

(d) If two more torches are added to positions A and C, what can be observed? [1]

SmileTutor.sg

Score	5
-------	---

34. Two different types of cells are shown in the diagram below.

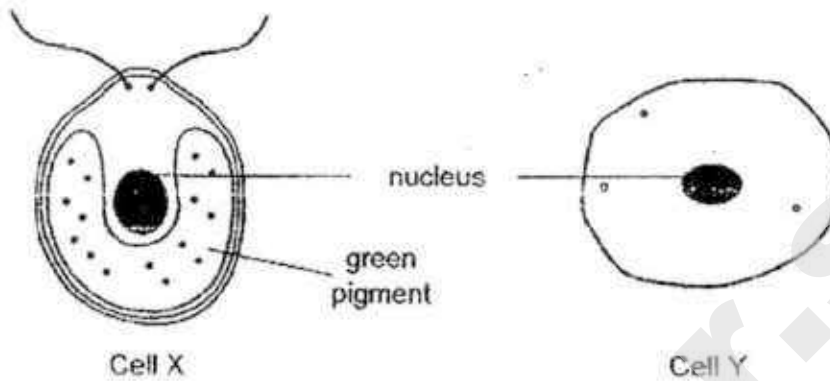

(a) Which cell, X or Y, is likely to be a plant cell? [1]

(b) Give two reasons to support your answer in (a)? [2]

(c) Name one part that is found in both cells X and Y besides the nucleus. [1]

Score	4
-------	---

35. The diagram below shows the cross-section of flower Y.

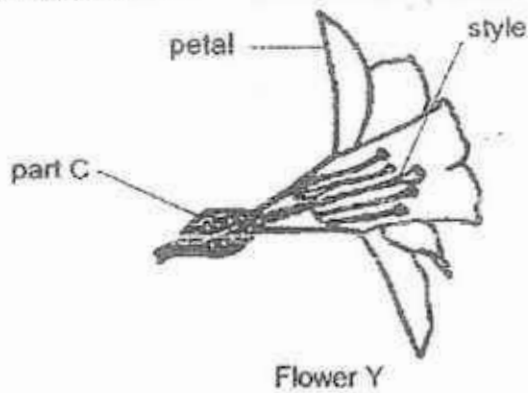

(a) What is the function of part C in the process of reproduction? [1]

(b) The diagram below shows the cross-section of flower X.
Draw an arrow in the diagram to indicate the process of pollination within flower X. [1]

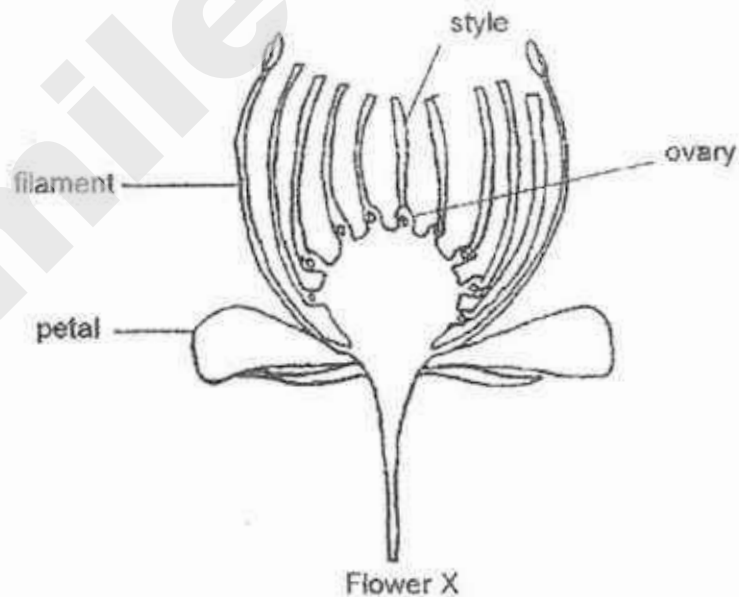

(Go on to the next page)

The fruit from flowers X and Y are shown in the diagram below.

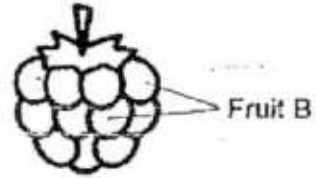
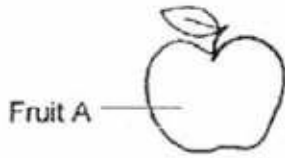

- (c) Which one of the fruits, A or B, comes from flower X? Explain your answer clearly. [2]

Score	4
-------	---

36. The diagram below shows animal X and its droppings.

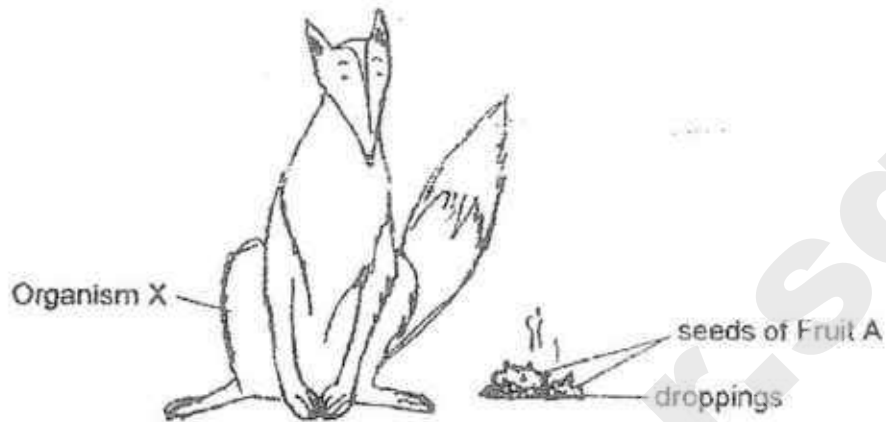

(a) Describe how the seeds of Fruit A ended up in animal X's droppings. [2]

(b) Give a reason why the seedlings that grew around the droppings are healthier. [1]

(c) Other than the seedlings growing healthier, give a reason why the dispersal of seeds is important in the reproduction of plants? [1]

Score	4
-------	---

37. The diagram below shows a set-up used to measure the temperature of the boiling water. After a while, salt was added and the temperature was taken.

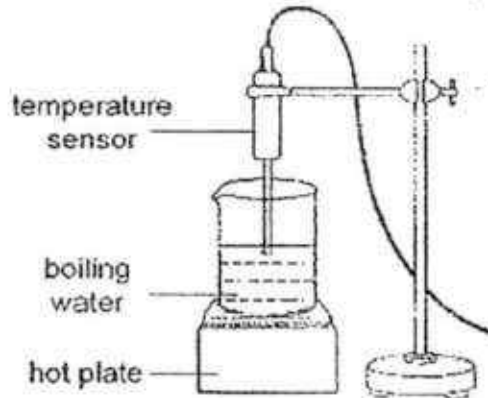

The readings of the temperature of boiling water before and after salt was added were plotted and shown in the graph below.

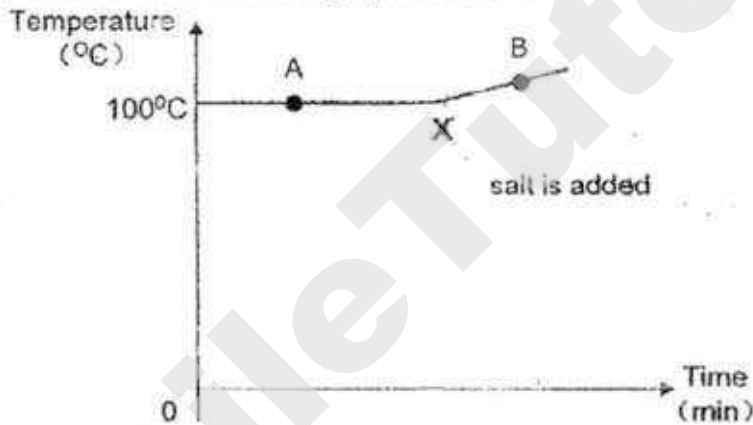

- (a) What is the advantage of using a temperature sensor to measure the temperature of boiling water? [1]

- (b) What happened to the boiling point of water after salt was added? [1]

- (c) At which point, A or B, will food be cooked faster? Explain your answer. [1]

38. The diagram below shows what can be done to get the dented ping pong ball to return to its original shape.

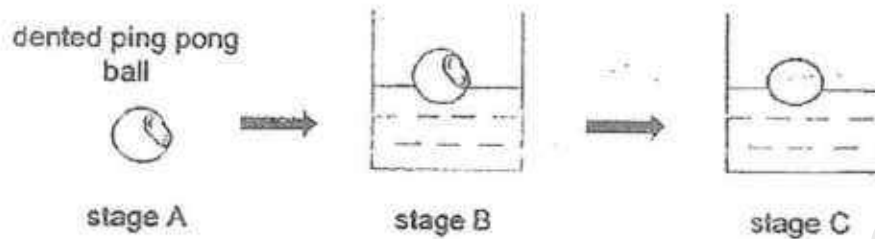

- (a) In stage B, was the ping pong ball put into hot water or cold water to get it to return to its original shape as shown in stage C? Explain your answer. [2]

- (b) Did the mass of the air inside the ping pong ball increase from stage B to C? Give a reason for your answer. [1]

- (c) What will happen to the air inside the ping pong ball if it is put into ice cold water after stage C? [1]

Score	4
-------	---

39. The diagram below shows the heating of a rod made of material A.



Before heating

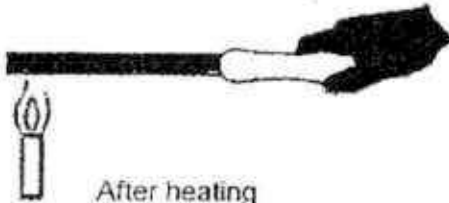

After heating

(a) Explain why the rod became bigger after heating?

[1]

Tiles made of Material A were laid on the floor. Tile spacers were put between the tiles as shown in the diagram below.

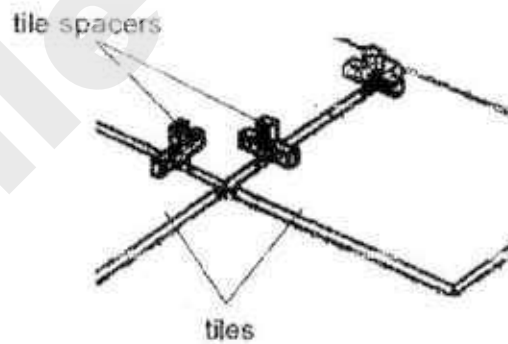

(b) In countries with high temperature, the presence of spaces between the tiles is very important? - Explain why it is important.

[2]

Score	3
-------	---

40. An experiment was conducted to find out the heat conductivity of different materials.

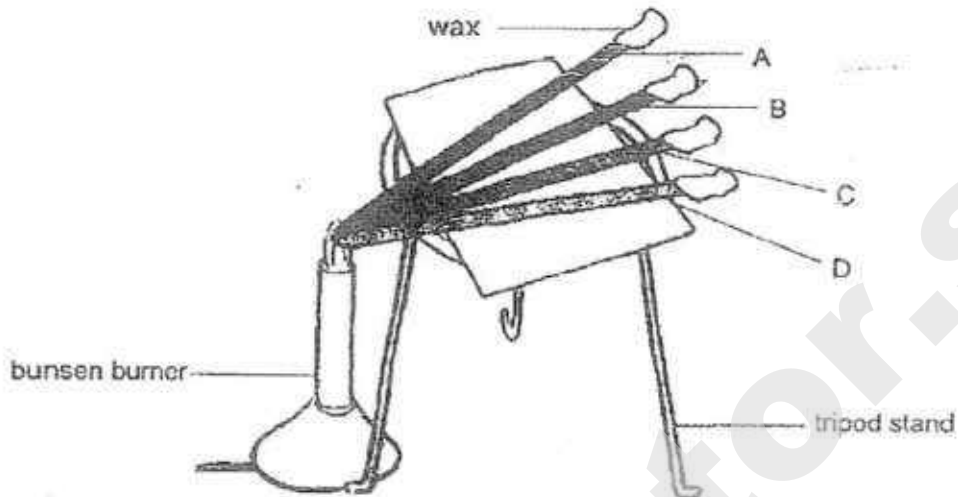

The time taken for the wax to melt completely was recorded in the table below.

Material	Time taken to melt the wax completely (mins)
A	10
B	15
C	48
D	55

(a) Which material is the best conductor of heat? Give a reason for your answer. [1]

(Go on to the next page)

The diagram below shows the cross section of a flask.

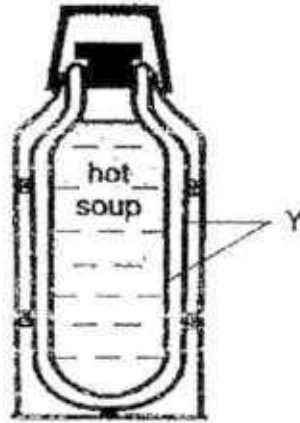

- (b) Which of the four materials, A, B, C or D, should be used to make part Y of the flask in order to keep the soup hot for the longest period of time? Explain your answer clearly. [2]

Score	3
-------	---

End of Paper

EXAM PAPER 2017 (P5)

SCHOOL : Nan Hua

SUBJECT : Science

TERM : CA1

Q1	Q2	Q3	Q4	Q5	Q6	Q7	Q8	Q9	Q10
1	2	3	2	3	3	4	4	2	3
Q11	Q12	Q13	Q14	Q15	Q16	Q17	Q18	Q19	Q20
4	2	2	4	1	3	2	1	4	2
Q21	Q22	Q23	Q24	Q25	Q26	Q27	Q28		
4	4	3	4	2	4	1	2		

29)a)Cell membrane

b)The cell membrane controls the movement of substance in and out of the cell.

c)Particle W pass through the filter paper and is inside the container.

d)To ensure the reliability of the results.

30)a)To not allow birds coming in for food.

b)The sweet and juicy fruit on the tree.

c)The flowers of the tree cannot be pollinated.

31)a)A mosquito has 4 stages in the life cycle but the frog has only 3.

b)Both the young does not look like the adult.

c) The pupa cannot move away while the tadpole can swim.

32)a) Set-up A acts as a control set-up and is used to compare and confirm that the presence of wind affects the rate of evaporation.

b) To find out if the exposed surface area will affect the rate of evaporation.

c) 1) Measure the amount of water left in the beaker at the end of the experiment.

2) Measure the time taken for each beaker of water to evaporate 20ml of water.

33)a)

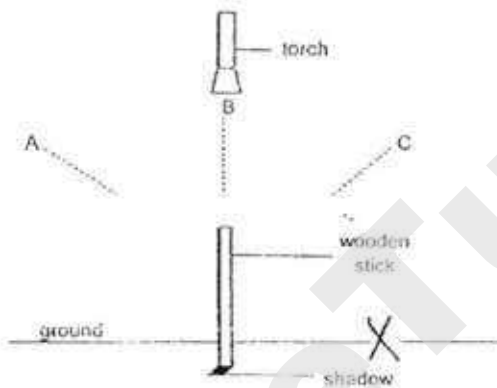

b) Move the torch further away from the wooden stick.

c)

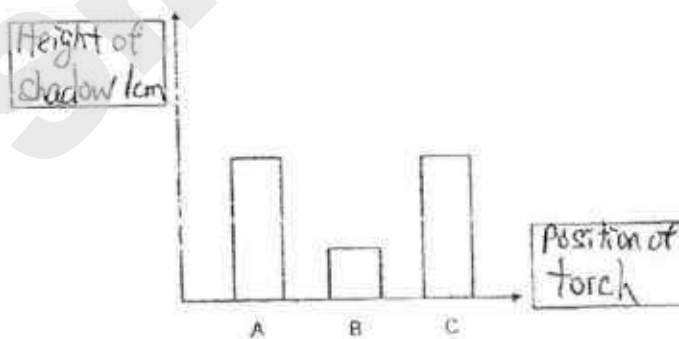

d) There will be 3 shadows.

34)a)Cell X

b)A plant cell has a cell wall and chloroplast, unlike Cell Y.

c)Cell membrane

35)a)The ovary produces the eggs

b)

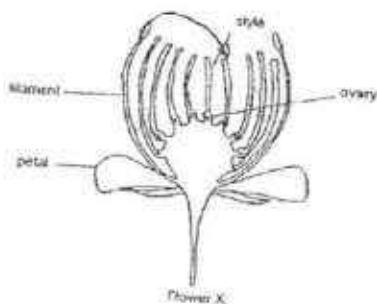

c)Fruit B. Flower X has many ovaries which will developed into many fruits after fertilization.

36)a)Animal X ate the fruit A with the seeds. The seeds are indigestible and passed out the droppings.

b)The droppings will decompose into nutrients and taken in by the seedlings.

c)This is to prevent over crowding so as to reduce competition for water, light, nutrients and space.

37)a)It will help it to be more accurate, as if you hold it with your hands and checking the temperature, the temperature will lost heat to your hands.

b)The boiling point increased

c)Point B. The food will gain more heat and cook faster.

38)a)Hot water. The air inside the ping pong ball will gain heat from the hot water and expand. The expanded air will push the dent out.

b)No. The mass of air did not increase as no air was removed or added in ping pong ball.

c)The air in the ping pong ball will lose heat to the cold water and contract.

39)a)The rod gain heat from the burner and expands.

b)When the tiles gain heat from the surroundings and expand, the space provides room for expansion thus the tile will not buckle.

40)a)Material A. It took the least time to melt the wax.

b)Material D. It took the longest time to melt the wax completely as it is poorest conductor of heat. It will take the most time for the hot soup to lose heat to the surroundings.

**CONTINUAL ASSESSMENT 1 / 2017
PRIMARY 5**

STANDARD SCIENCE

(BOOKLET A)

Name : _____ ()

Date : 8 March 2017

Class : P5 _____

Total Time for Booklet A & Booklet B : 1 hour

INSTRUCTIONS TO CANDIDATES

1. Write your name, index number and class in the space above.
2. Do not turn over this page until you are told to do so.
3. Follow all instructions carefully.
4. Answer all questions.
5. For Section A, shade your answers for questions 1 to 10 in the Optical Answer Sheet (OAS) provided.
6. For Section B, write your answers for questions 11 to 18 in the space provided in the booklet.
7. The total marks for Booklet A is 20 marks.

Section A (20 marks)

For each question 1 to 10, four options are given. One of them is the correct answer. Make your choice (1, 2, 3 or 4). Shade the oval (1, 2, 3 or 4) on the Optical Answer Sheet.

1. The table below provides some information on three cell specimens P, Q and R taken from parts of animal or plant.

A tick (✓) indicates the presence of the part of the cell.

	Cell P	Cell Q	Cell R
Nucleus	✓	✓	✓
Chloroplasts		✓	
Cell wall	✓	✓	

Which of the following best represent the characteristics of the three cell specimens above?

	Cell P	Cell Q	Cell R
(1)	Stem	Leaf	Cheek
(2)	Leaf	Stem	Cheek
(3)	Stem	Cheek	Leaf
(4)	Cheek	Leaf	Stem

()

2. The diagram below shows a cell.

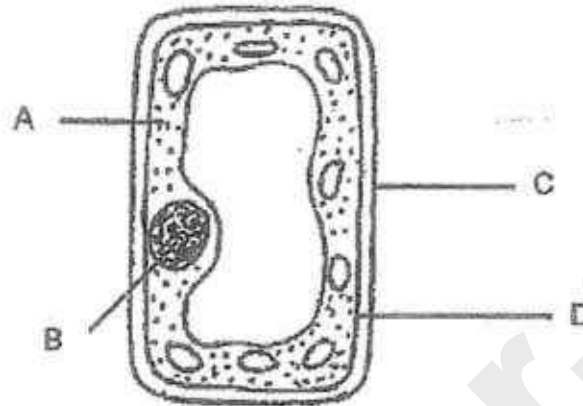

Different parts of the cell are labelled as A, B, C, and D.

Which of the following correctly identifies the parts of the cell?

	Can also be found in animal cells	Allows water to enter the cell	Maintains the size of the cell
(1)	A and B	C	A
(2)	A, C and D	D	B
(3)	A, B and D	C and D	C
(4)	A, B, C and D	C and D	D

3. The table below shows the similarities between parts of the reproductive systems in a human and flowering plant.

Parts of reproductive system	Flowering plant	Human
Male reproductive part	P	Testis
Male sex cell	Pollen grain	Q
Female reproductive part	R	Ovary
Female sex cell	Ovule	Egg
After fertilisation	S is formed	A foetus is formed

Which one of the following correctly shows what P, Q, R and S are?

	P	Q	R	S
(1)	filament	penis	stigma	seed
(2)	anther	sperm	stigma	fruit
(3)	filament	penis	ovary	seed
(4)	anther	sperm	ovary	fruit

4. Rahim identified three flowers from the same plant and labelled them W, X and Y. After removing one part from each flower, he dusted pollen grains from the same plant onto the three flowers W, X and Y.

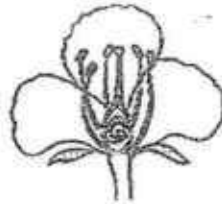

The table below shows the results after one month.

Flower	Part removed	Did the flower become a fruit?
W	L	No
X	M	Yes
Y	N	Yes

What could parts L, M and N be?

	L	M	N
(1)	Anther	Ovules	Petal
(2)	Stigma	Petal	Anther
(3)	Petal	Anther	Stigma
(4)	Stigma	Ovules	Anthers

()

5. Which one of the following shows the correct order of the processes in the life cycle of a flowering plant?

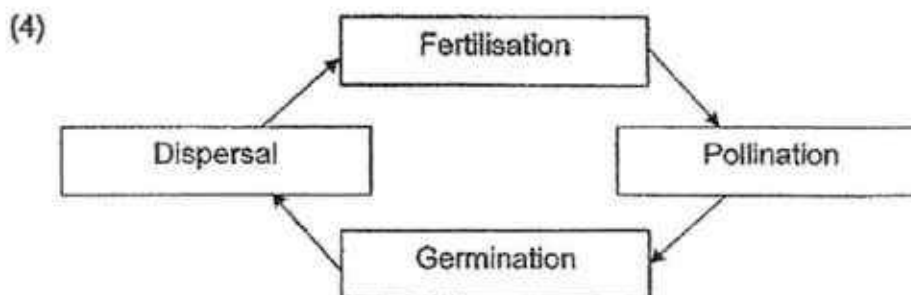
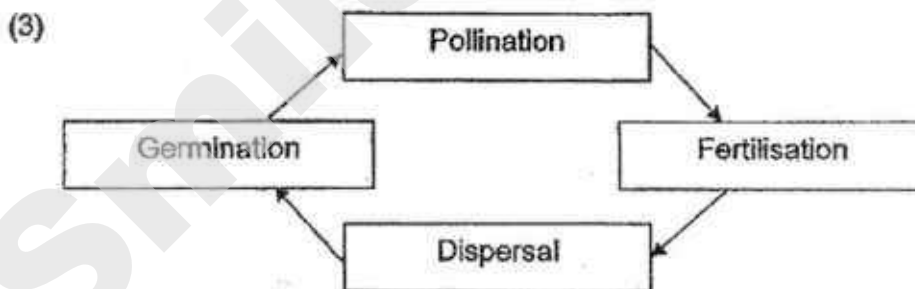
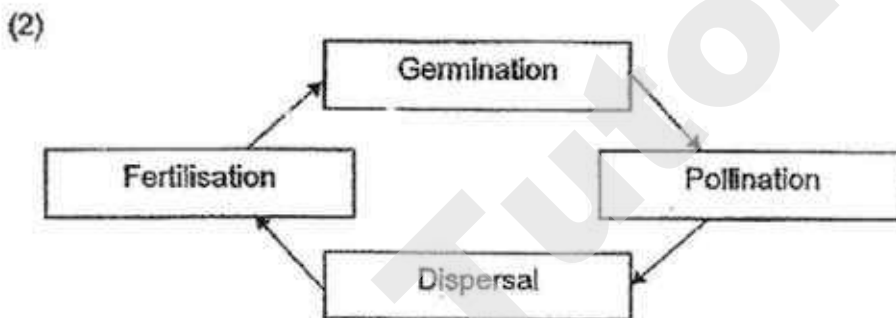
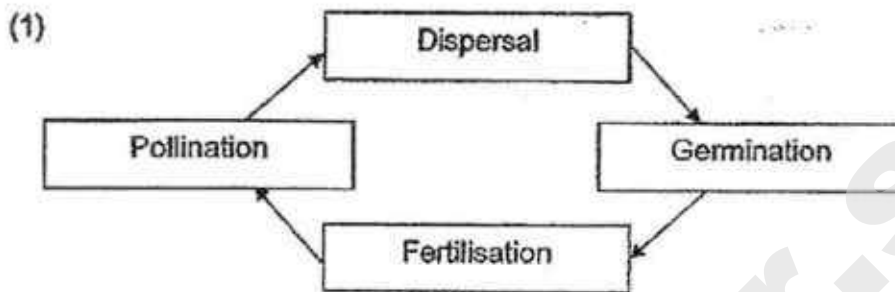

6. Hayley wanted to find out how the structure of a fruit would affect the time it stay in the air. She made a few fruit models to conduct her experiment. A sample setup is as shown below.

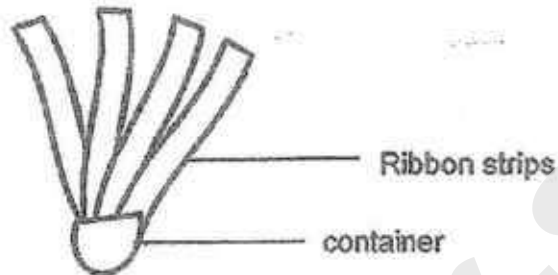

Which of the following must Hayley keep the same to ensure a fair test?

- A. Number of ribbon strips
- B. Mass of container
- C. Height at which the fruit model was dropped
- D. Time taken for fruit model to stay in the air

- (1) A and D only
- (2) B and C only
- (3) A, B and C only
- (4) A, B, C and D

()

7. The diagram below shows the cross section of Fruit A.

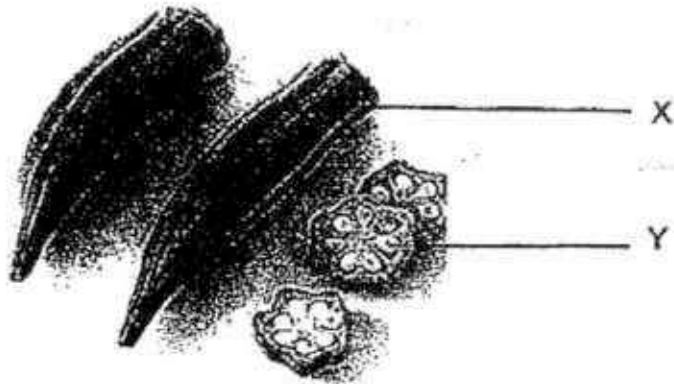

Which part of Fruit A does X and Y develop from?

	X	Y
(1)	stigma	Pollen grains
(2)	petals	anther
(3)	ovary	ovules
(4)	Pollen tube	petals

8. The diagram below shows the human female reproductive system.

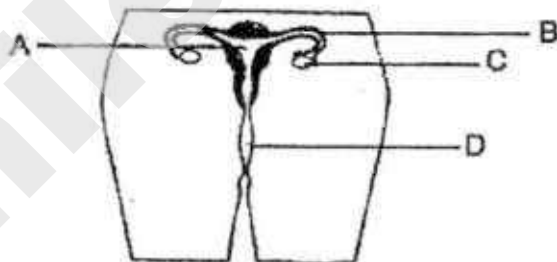

At which part of the female reproductive system, A, B, C or D, are the female reproductive cells produced?

- (1) A
- (2) B
- (3) C
- (4) D

9. The diagram below shows the members of Benny's family who carry the genetic trait for Disease X.

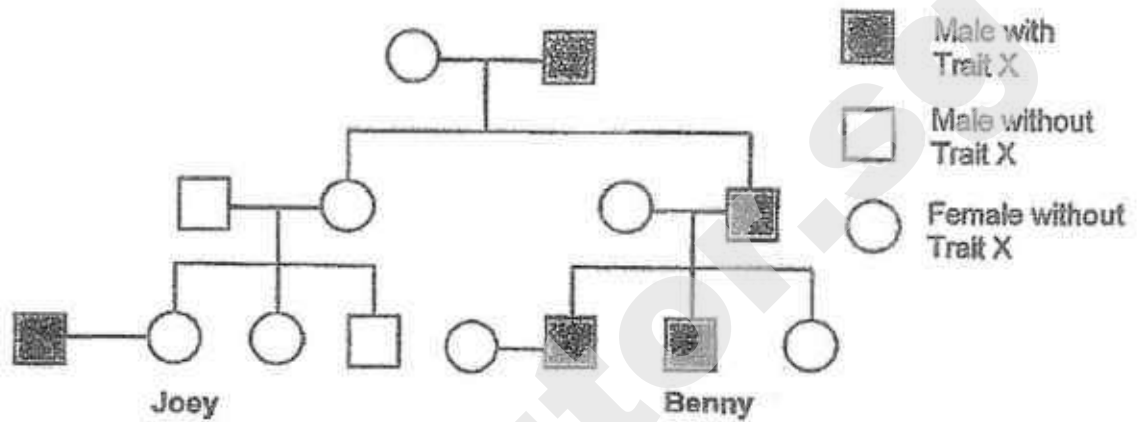

Based on the information above, which of the following statements can be concluded?

- A: Only males will have Trait X.
 B: Benny inherited the genes of Trait X from his father.
 C: Parents without Trait X will not have offspring with Disease X.

- (1) A only
 (2) B only
 (3) B and C only
 (4) A, B and C

()

10. Kamal studied the two reproductive systems as shown below.

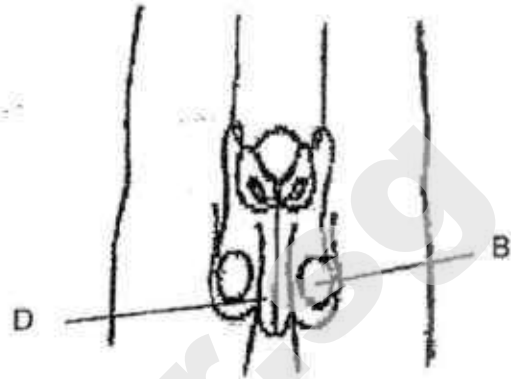
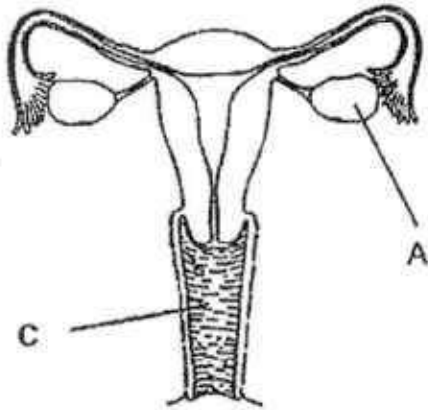

He made the following statements.

A. Part A and Part B contain the female and male reproductive cells respectively.

B: The fertilised egg will develop in Part C.

C. It takes 9 months for cells in Part A and Part B to fertilise.

D. Part D releases 1 sperm to fertilise with the egg cell.

Which statement(s) is/are correct?

(1) A only

(2) A and D only

(3) B and C only

(4) A, C and D only

()

~ End of Booklet A ~

**CONTINUAL ASSESSMENT
1 / 2017 PRIMARY 5.**

STANDARD SCIENCE

(BOOKLET B)

Name : _____ ()

Date : 6 March 2017

Class : P5 _____

Total Time for Booklet A & Booklet B : 1 hour

INSTRUCTIONS TO CANDIDATES

1. Write your name, index number and class in the space above.
2. Do not turn over this page until you are told to do so.
3. Follow all instructions carefully.
4. Answer all questions.
5. For Section A, shade your answers for questions 1 to 10 in the Optical Answer Sheet (OAS) provided.
6. For Section B, write your answers for questions 11 to 16 in the space provided in the booklet.
7. The total marks for Booklet B is 30 marks.

Booklet A		/20
Booklet B		/30
Total		/50
Parent's Signature		

Section B (30 marks)

Write your answers to questions 11 to 16 in this booklet.

11. Some students observed a cell when it cut on as shown below.

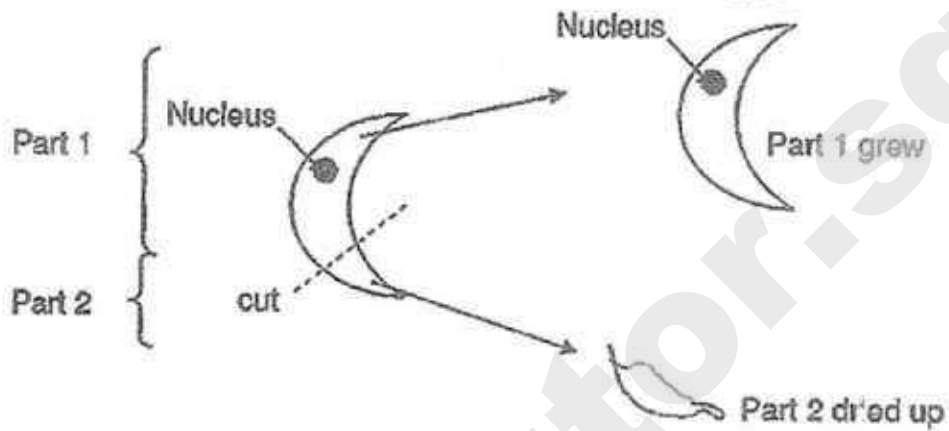

- (a) It was observed that after the cut, Part 1 grew into the same identical cell. However Part 2 shrivelled and dried up. Explain how did it happen? (2m)

	2
--	---

(b) The scientist found another cell, Cell X, as shown below.

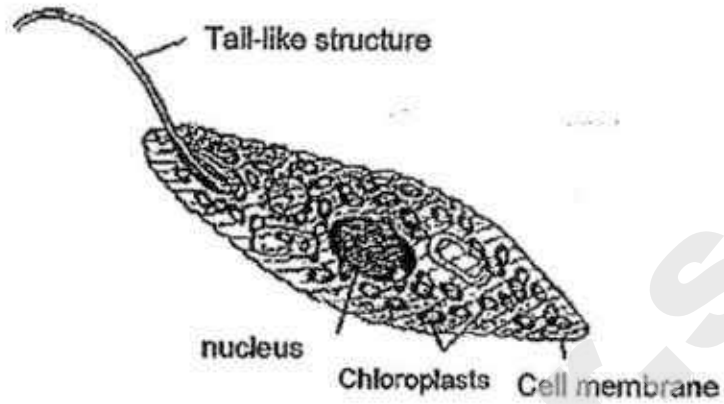

(i) From your observation of Cell X above, is the cell a plant cell or an animal cell? Explain your answer. (1m)

(ii) What are the two possible functions of the tail-like structure of the cell above? (2m)

	3
--	---

12. Jianwei found two flowering plants in his garden as shown below.

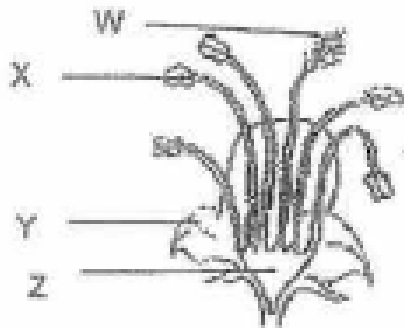

Plant A

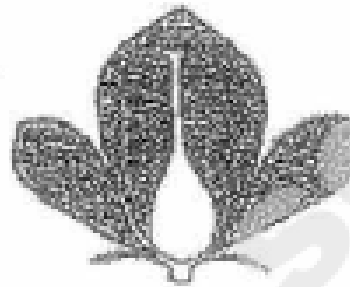

Plant B

A disease has killed the insects in his garden. After some time, he recorded the number of fruits found on both plants.

	Plant A	Plant B
Number of fruits on Day 1	0	0
Number of fruits on Day 25	18	2
Number of insects surrounding the plants	0	0
Presence of wind	Yes	Yes

(a) Which plant is less affected by the absence of insects? Explain your answer. (2m)

(b) Which part(s), W, X, Y and Z of flower of plant A must be present for flowers to develop into a fruit? (1m)

(c) From his record, Jianwei noticed that fruits of Plant B were still able to develop despite the absence of insects. What could be the possible reason? (2m)

	5
--	---

**BLANK
PAGE**

SmileTutor.sg

13. Azza conducted an experiment to investigate the effects of temperature on the distance seeds are scattered from their parent plants.

He selected three fruits, M, N and P, from the same species of plant located at three locations with different surrounding temperature.



He recorded his findings in the table below.

Fruit	Temperature of the surrounding (°C)	Distance the seeds were scattered from the parent plant (m)
M	18	0.6
N	25	1.5
P	39	2.8

(a) Based on the results in the table, how did the temperature of the surrounding affect the distance at which the seeds were scattered? [1m]

(b) Name one other variable that should be kept constant to ensure the experiment is carried out fairly. [1m]

	2
--	---

(c) Azza found Fruit Q as shown below.

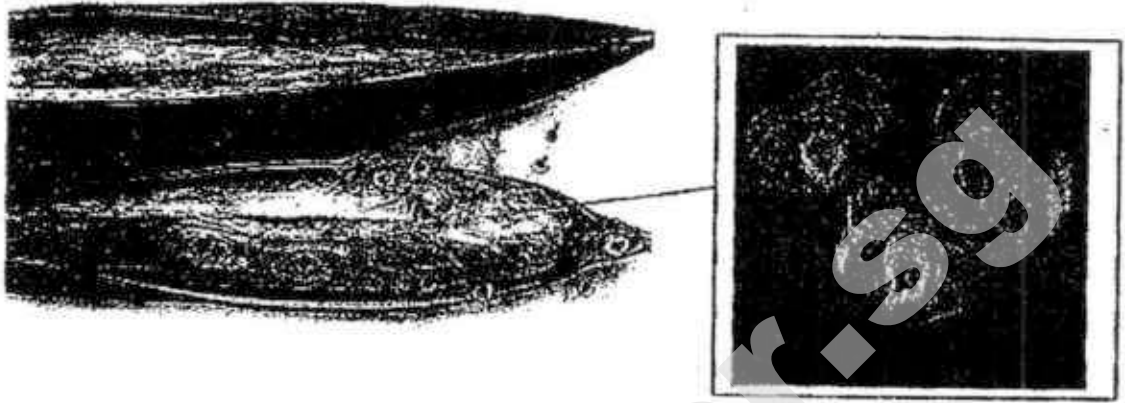

He noticed that Fruit Q dispersed in the same way as Fruit M, N and P. The seeds of Fruit Q scattered further than seeds of Fruit M, N and P. Give a reason for this. [1m]

(d) Azza concluded that Fruit Q allows its young plants to grow better than Fruit M, N and P. Explain Azza's conclusion. [2m]

	3
--	---

14. Gillian found 2 types of plants in a field and recorded her observations in the table below.

	Leaves	Stems	Flower	Fruits/ seeds
Plant 1	Small	Long	Small and coloured	Pod-like. Turns brown and dry when ripe.
Plant 2	Long and thin	Thick and long	Has white, feather-like stigmas	Has a fibrous husk

- (a) Based on her observations above, state the methods of pollination and seed dispersal of Plant 1 and Plant 2. (2m)

	Method of pollination	Method of seed dispersal
Plant 1		
Plant 2		

	2
--	---

- (b) The diagram below shows the locations of Plant 3 in an area.
X shows the parent plant and W shows the young plants.

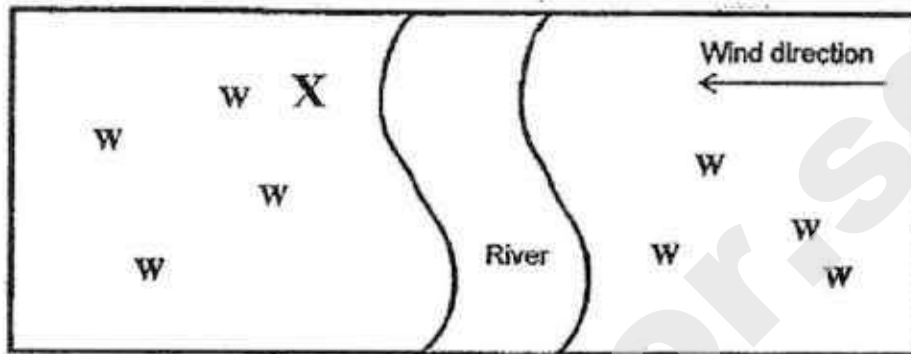

- (i) Gillian concluded that Plant 3 is dispersed by wind. Is she correct?
Explain your answer. (1m)

- (ii) Based on the diagram above, identify the method of dispersal and the possible characteristics of Plant 3. (1m)

- (c) Gillian noticed a new type of plant, Plant A. The fruits of Plant A contain a fibrous covering. Draw the symbol - (A) in the above diagram to show where the fruits of Plant A are most likely to be found. (1m)

	3
--	---

15 The diagram below shows a baby in a female reproductive system.

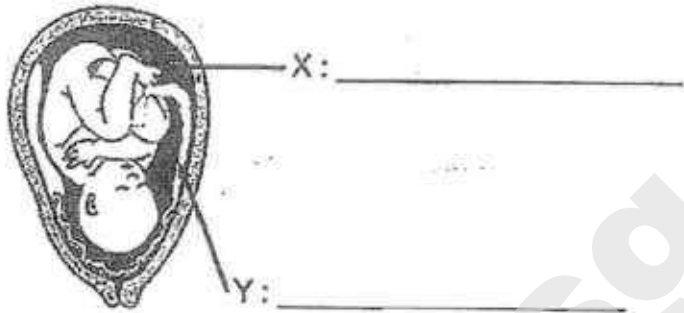

(a) Identify and label clearly the parts X and Y in the diagram above. [1m]

(b) If part Y is not able to function properly, give 2 ways in which the developing baby would be affected. [2m]

(i) _____

(ii) _____

(c) To control birth, a device is placed in the female reproductive system as shown below.

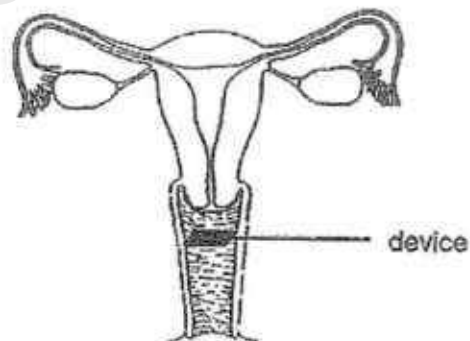

How does the device prevent fertilisation from taking place? (2m)

	5
--	---

16. The diagram below shows the family tree of Sally, Brenda and Sam.

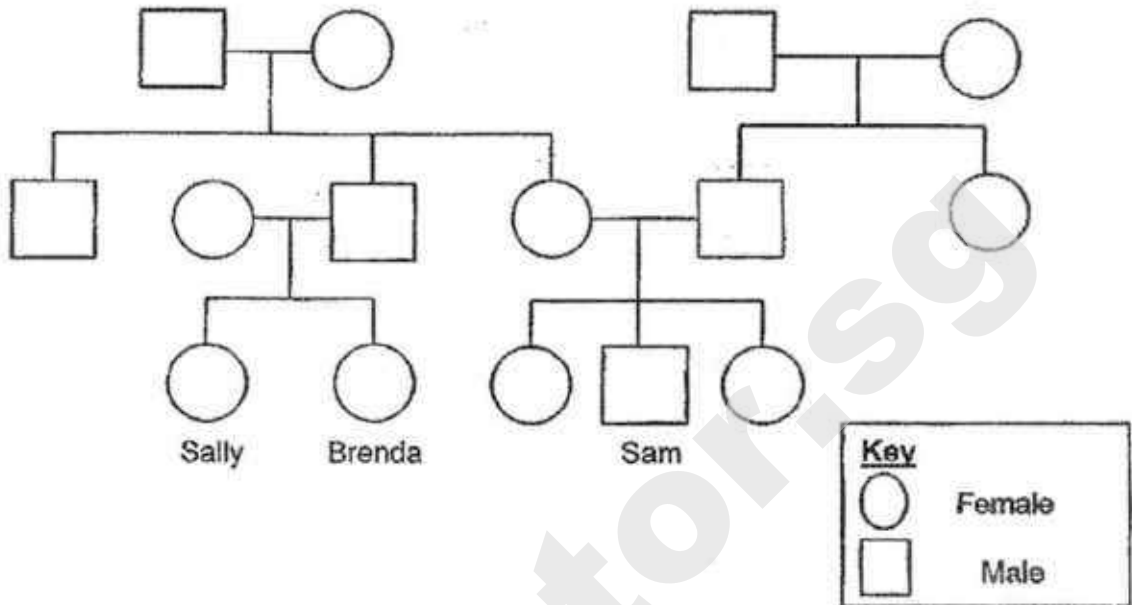

(a) Based on the information above, put a tick (✓) in the correct boxes to indicate whether the statements are True, False or Not possible to tell. [2m]

	Statements	True	False	Not possible to tell
(a)	Sam has two sisters.			
(b)	Brenda and Sally are twins.			
(c)	Sam's father has four nieces.			
(d)	Brenda's father and Sam's mother are siblings.			

(b) Draw on the family tree based on the following information below. (2m)

- Sally got married a few years ago.
- She has 2 sons and 1 daughter.

(c) Sally has straight hair. She noticed that her daughter has curly hair like her mother. Explain how Sally's daughter has curly hair. (1m)

	5
--	---

~ End of Paper ~

SCHOOL : RIVER VALLEY PRIMARY SCHOOL
LEVEL : PRIMARY 5
SUBJECT : SCIENCE
TERM : CA1

BOOKLET A

Q 1	Q2	Q3	Q4	Q5	Q6	Q7	Q8	Q9	Q10
1	3	4	2	3	2	3	3	4	1

BOOKLET B

Q11)	<p>(a) As there is a nucleus in Part 1, it would be able to grow. As part 2 does not have a nucleus, it will not grow like part 1 and dry up.</p> <p>(b)</p> <p>(i) It is an animal cell. Although it has chloroplasts, it does not have a cell wall.</p> <p>(ii) The functions are to swim away from predators and to enable it to swim while looking for food.</p>
Q12)	<p>(a) Plant A. Although there was no presence of insects, the number of fruits increased from 0 to 18 in the presence of wind.</p> <p>(b) W and Z</p> <p>(c) There could have been other pollinators carrying pollen grains that came into contact with the stigma of B and fused with the female reproductive cell of B during fertilization. This allowed fruits to be developed.</p>

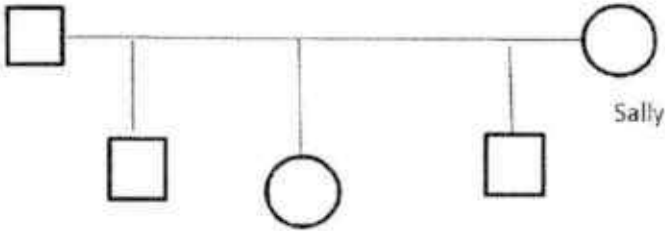
Q13)	<p>(a) The greater the temperature, the further the seeds scatter from the parent plant.</p> <p>(b) The size of the fruit.</p> <p>(c) Fruit Q has a wing-like structure and is light.</p> <p>(d) It is to prevent overcrowding and competition for water, space and mineral salts.</p>
Q14)	<p>(a) Plant 1: By animals, Explosive/Splitting action. Plant 2: By wind, By water</p> <p>(b)(i) No. This is because the seeds are scattered everywhere but not in the wind's direction. (ii) By animals. Its fruit should be sweet and fleshy.</p> <p>(c)</p> 
Q15)	<p>(a) X: womb Y: umbilical cord</p> <p>(b)(i) The baby cannot get enough food and nutrients. (ii) Waste products cannot be removed from the developing baby.</p> <p>(c) The sperm cannot enter the fallopian tube to fuse with the egg and fertilization cannot take place.</p>
Q16)	<p>(a) T, NPTT, F and T</p> <p>(b)</p>  <p>(c) Sally's daughter has inherited her curly hair from Sally's mother.</p>

Name: _____)

Class: Primary 5 _____

**Primary 5
CONTINUAL ASSESSMENT 1
SCIENCE**

BOOKLET A

2 March 2017

Total Time for Booklets A and B: 1 hour 15 minutes

**15 questions
30 marks**

**Do not open this booklet until you are told to do so.
Follow all instructions carefully.
Answer all questions.**

This booklet consists of 11 printed pages.

Section A (15 x 2 marks = 30 marks)

For each question from 1 to 30, four options are given. One of them is the correct answer. Make your choice (1, 2, 3 or 4). Shade the correct oval (1, 2, 3 or 4) on the Optical Answer Sheet provided.

1. The graph below shows the number of days each stage in the life cycle of an organism lasts.

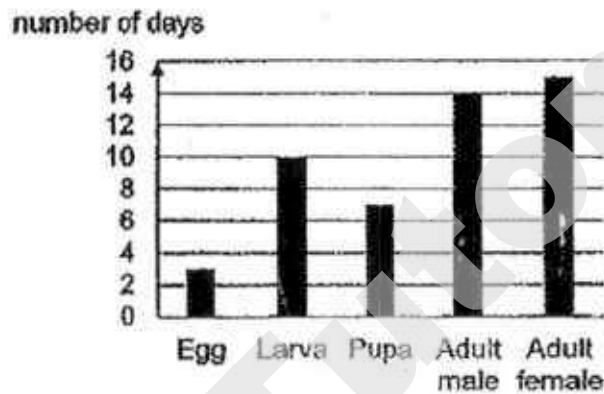

Based on the graph above, which of the following statement(s) is/are definitely true?

- A The young looks like the adult.
- B The longest stage is the adult stage.
- C There are four stages in the life cycle of the organism.
- D It takes 20 days for the organism to become an adult after hatching.

- (1) A and D only
- (2) B and C only
- (3) C and D only
- (4) B, C and D only

2. Study the diagram below.



Which one of the following describes what happens to his ribcage and diaphragm when the boy is blowing into his trumpet to produce a sound?

	Ribcage	Diaphragm
(1)	Move in and downwards	Move downwards
(2)	Move in and downwards	Move upwards
(3)	Move out and upwards	Move upwards
(4)	Move out and upwards	Move downwards

3. The diagram below shows the human respiratory system.

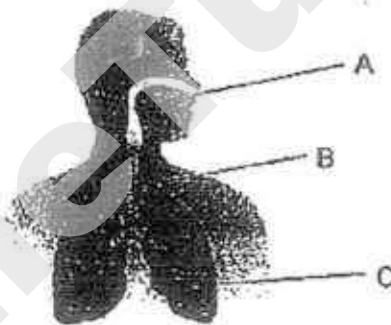

Based on the diagram above, which of the following statements are correct?

- A Part A allows air to enter and leave the body.
 - B Part B allows the passage of air to the lungs.
 - C Part B traps the dust from entering the lungs.
 - D Part C contains air sacs which are covered with many blood vessels.
- (1) A and B only
 (2) A, B and D only
 (3) A, B and C only
 (4) A, B, C and D

4. The pie chart below shows the composition of air in the atmosphere.

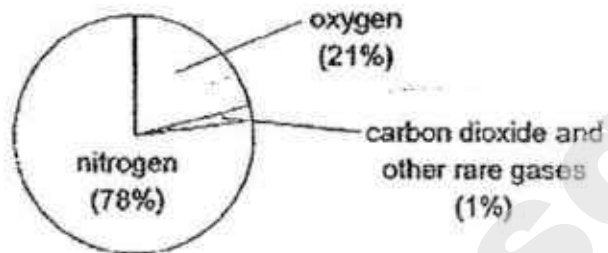

Which one of the following shows the composition of exhaled air?

(1)

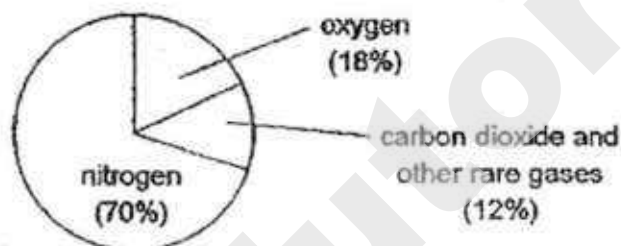

(2)

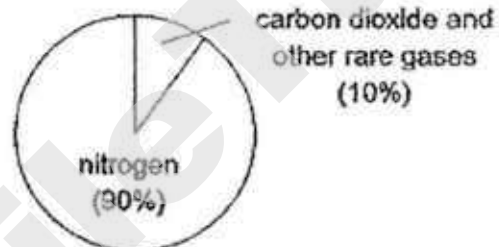

(3)

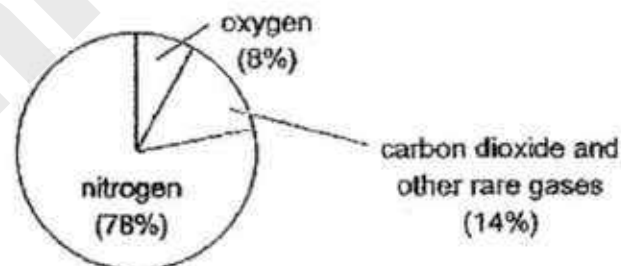

(4)

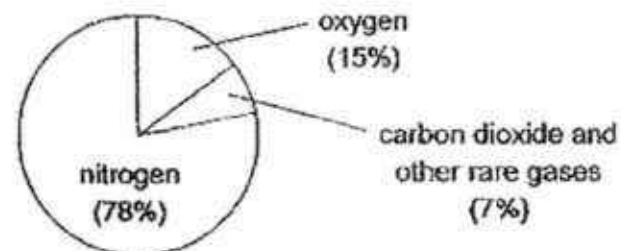

5. The diagram below shows how sugar and water are transported to different parts of a plant.

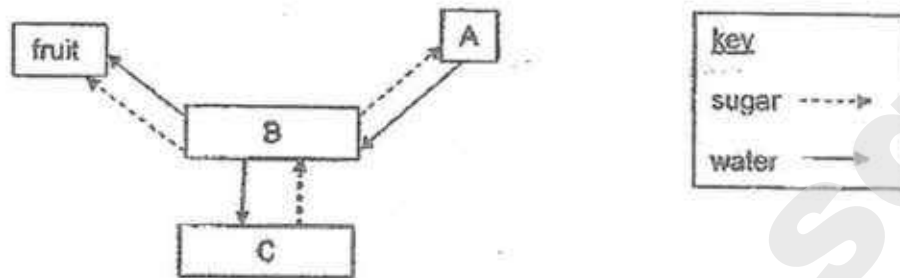

Which one of the following correctly shows the parts of the plant that are represented by A, B and C?

	A	B	C
(1)	leaves	stems	roots
(2)	stems	roots	leaves
(3)	roots	stems	leaves
(4)	roots	leaves	stems

6. A small, thin outer ring from the stem of a plant growing in an open field was removed. A few days later, there was a swelling above the cut.

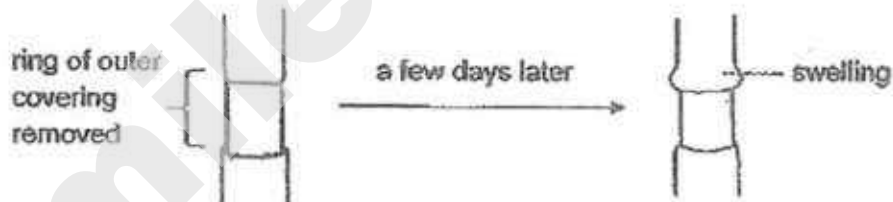

Which of the following correctly explains the presence of the swelling on the stem?

- (1) Food travelling up the stem was trapped above the ring.
- (2) Water travelling up the stem was trapped above the ring.
- (3) Food travelling down the stem was trapped above the ring.
- (4) Water travelling down the stem was trapped above the ring.

7. Study the diagram below.

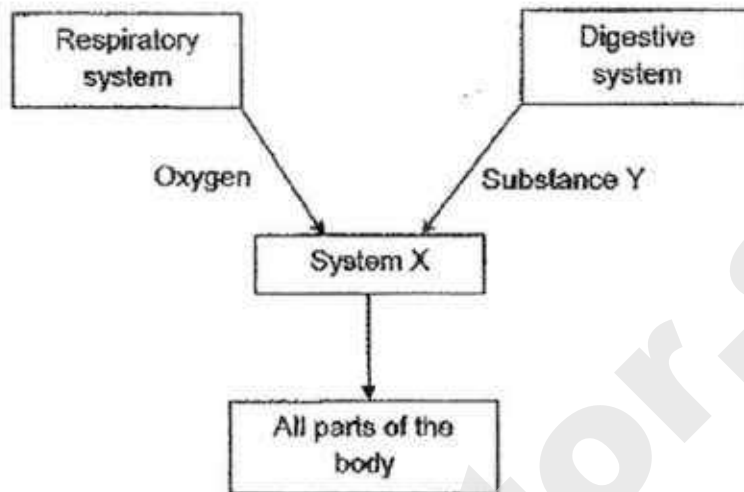

Which one of the following best represents System X and Substance Y?

	System X	Substance Y
(1)	Muscular	Digested food
(2)	Circulatory	Digested food
(3)	Muscular	Undigested food
(4)	Circulatory	Undigested food

8. Jacob set up an experiment as shown below. As he slid the magnet along the underside of the table, he noticed that the steel coin moved along the direction shown below.

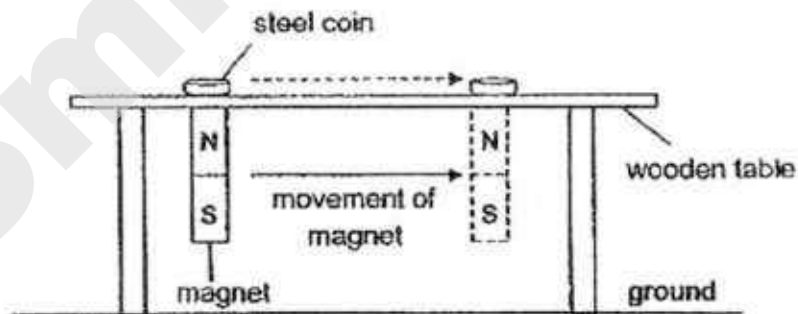

What was the aim of Jacob's experiment?

- (1) To find out if the magnet can attract different kinds of metals.
- (2) To find out if different poles of the magnet can attract the steel coin.
- (3) To find out if magnetic force can pass through non-magnetic materials.
- (4) To find out if the North pole of the magnet attracts or repels the steel coin.

9. Which of the following does not weaken the strength of a magnet?

- (1) Boiling it in a kettle of hot water.
- (2) Dropping it several times from a desk.
- (3) Using it to stroke an iron nail repeatedly.
- (4) Hammering it continuously for two minutes.

10. Felix placed some ice cream into a metal bowl as shown below. He noted that the ice cream started to melt very quickly. The side of the bowl also felt cold when he touched it with his hands.



Which one of the following statements best explains Felix's observations?

	Melting of ice cream	Bowl felt cold to touch
(1)	The ice cream lost heat to its surroundings.	The bowl lost heat to the ice cream.
(2)	The ice cream lost heat to the bowl.	The bowl gained heat from the ice cream.
(3)	The ice cream gained heat from its surroundings.	The bowl gained heat from Felix's hands.
(4)	The ice cream gained heat from the bowl.	The bowl lost heat to Felix's hands.

11. Study the diagram below carefully.

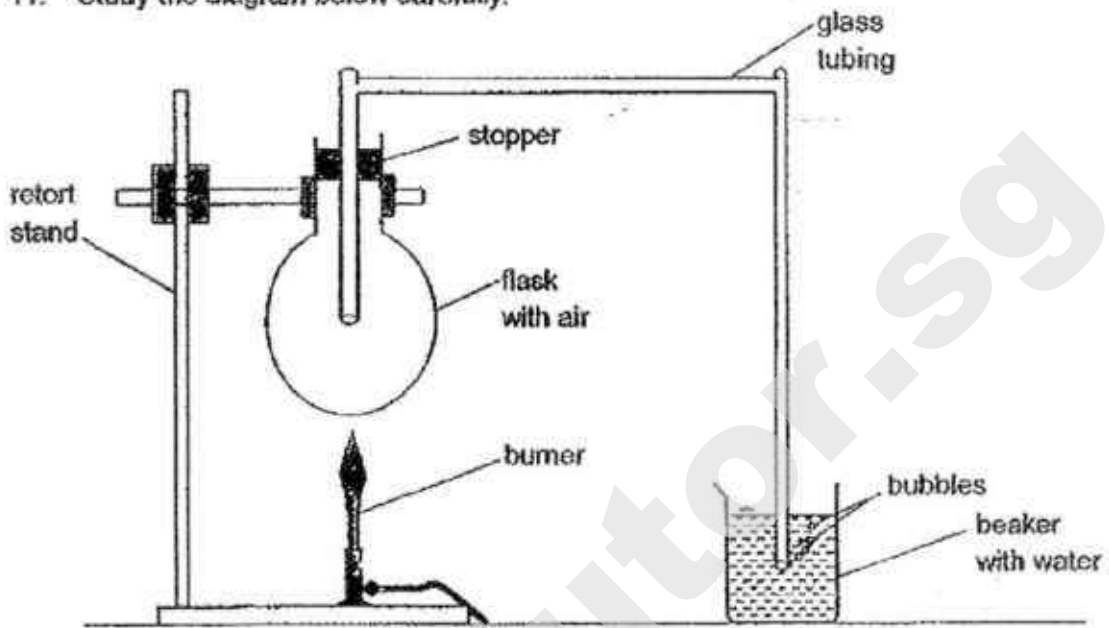

When the flask is warmed, bubbles appear at the mouth of the glass tubing in the beaker of water. Which one of the following is the reason for the observation?

- (1) The flask loses heat to the air and contracts.
- (2) The flask gains heat from the flame and expands.
- (3) The air in the flask loses heat to the flask and contracts.
- (4) The air in the flask gains heat from the flame and expands.

12. Ravi conducted an experiment using the set-ups shown below. The containers were filled completely with an equal amount of boiling water and left on a table. He recorded the temperature of the water in each container at intervals of 2 minutes for 30 minutes.

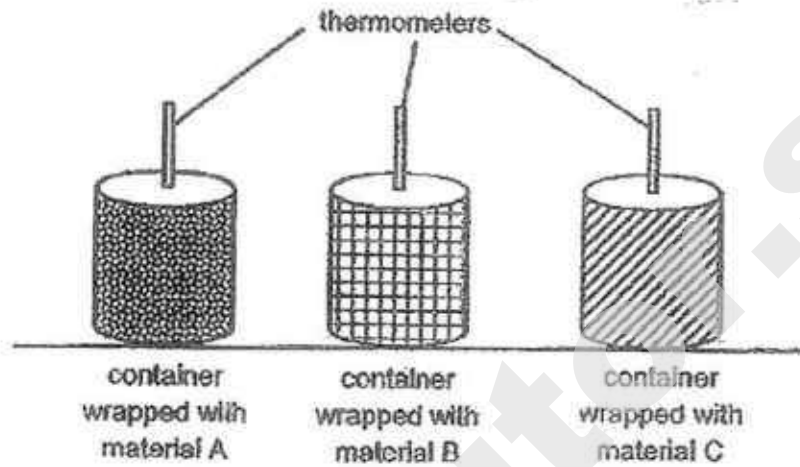

Which of the following could be possible aim(s) of his experiment?

- A To find out which container is a better conductor of heat.
- B To find out how fast boiling water loses heat to its surroundings.
- C To find out which material can best keep the water warm for a longer time.
- D To find out whether the number of layers of the different materials would affect the time taken for the water to cool.

- (1) C only
- (2) A and C only
- (3) B and D only
- (4) A, B and D only

13. Kim set up an experiment using two glass containers, A and B, as shown below. Each container has a capacity of 1000 cm^3 .

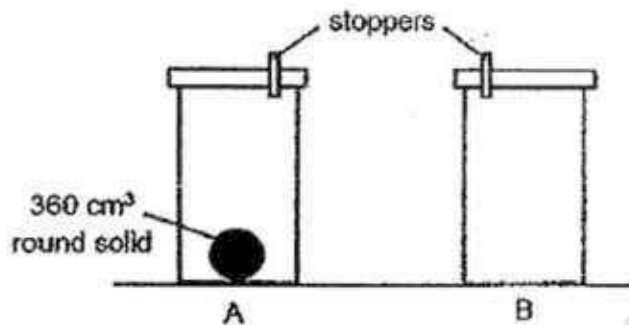

The stoppers were removed and 600 cm^3 of air was pumped into container A while 450 cm^3 of air was pumped into container B. What would the final volume of the air in each glass container be?

	Container A	Container B
(1)	1360 cm^3	1450 cm^3
(2)	1000 cm^3	1450 cm^3
(3)	1000 cm^3	1000 cm^3
(4)	640 cm^3	1000 cm^3

14. A sealed styrofoam cup of ice was placed on an electronic balance as shown below. The mass of the cup of ice is 58g .

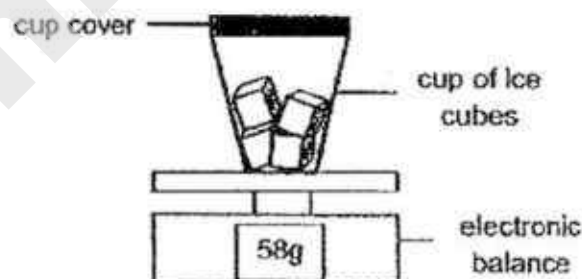

Assuming that any water droplets formed on the cup is insignificant, what would the reading on the scale be when all the ice cubes in the cup had melted?

- (1) 58g
- (2) More than 58g
- (3) Less than 58g
- (4) Not possible to tell

15. The diagram below shows a U-shaped container filled with water. The water level at points K and L are the same.

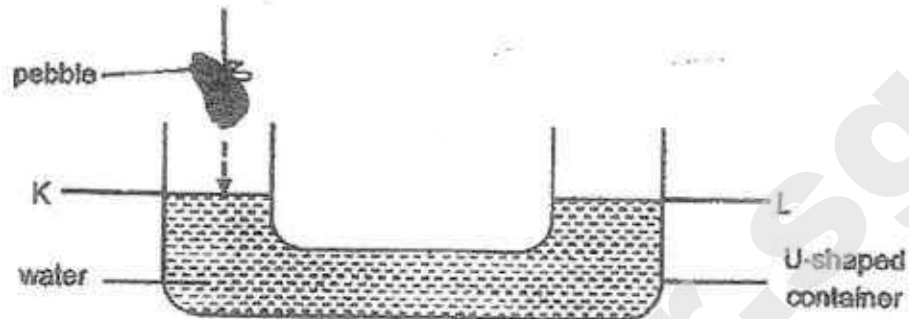

Which one of the following statements best describes the water level at points K and L when the pebble is carefully lowered into the container as shown above?

- (1) The water level at K and L will increase.
- (2) The water level at K will increase more than the water level at L.
- (3) The water level at L will increase more than the water level at K.
- (4) The water level at L will decrease but the water level at K will increase.

End of booklet A

Primary 5
CONTINUAL ASSESSMENT 1
SCIENCE
BOOKLET B
2 March 2017

NAME: _____ ()

CLASS: Primary 5 _____

Total Time for Booklets A and B: 1 hour 15 minutes

7 questions
20 marks

Do not open this booklet until you are told to do so.
Follow all instructions carefully.
Answer all questions.

This paper consists of 8 printed pages.

Booklet A	30
Booklet B	20
Total	50

Parent's Signature/Date

Section B (20 marks)

For questions 16 to 22, write your answers in this booklet.

The number of marks available is shown in the brackets [] at the end of each question or part question.

16. Amanda planted four similar bean seeds in different positions in a container of soil as shown in diagram A.

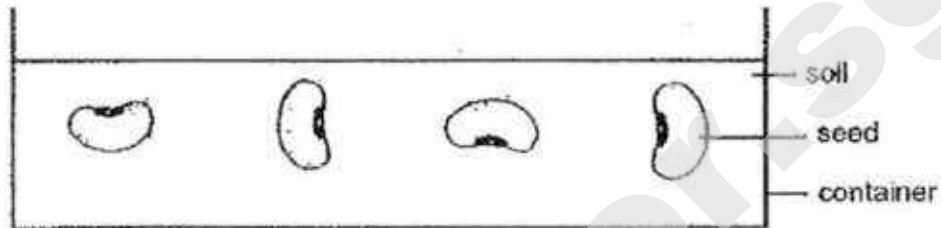

diagram A

Within a week, she made the following observations as shown in diagram B.



diagram B

- a) Based on Amanda's observation, does the position in which the bean seed was planted affect the way the seedling grows? Explain your answer. [1]

- b) State one difference between the life cycle of the bean plant and the life cycle of a fern. [1]



17. Danny set up an experiment as shown below. He wanted to find out whether the roots of the plant absorb water. The water levels in the beakers X, Y and Z were recorded at the end of each day over a period of one week.

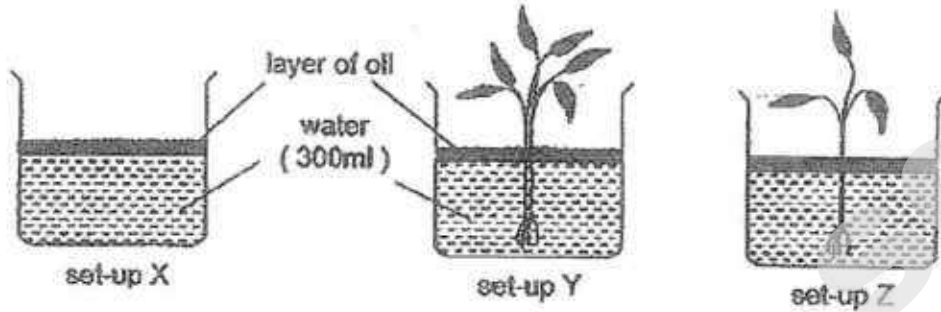

- a) What is the purpose of set-up X? [1]

- b) The graph below shows the changes to the water level for set-up Y over a period of a week. Draw and label the graphs for set-up X and set-up Z. [2]

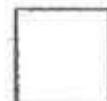
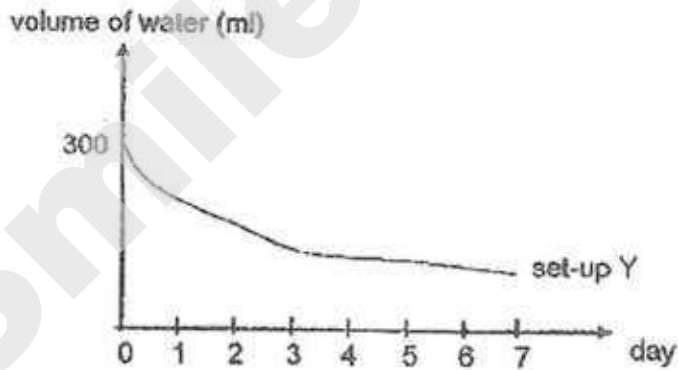

18. The graph below shows Damien's heart rate from 4pm to 6pm on an afternoon.

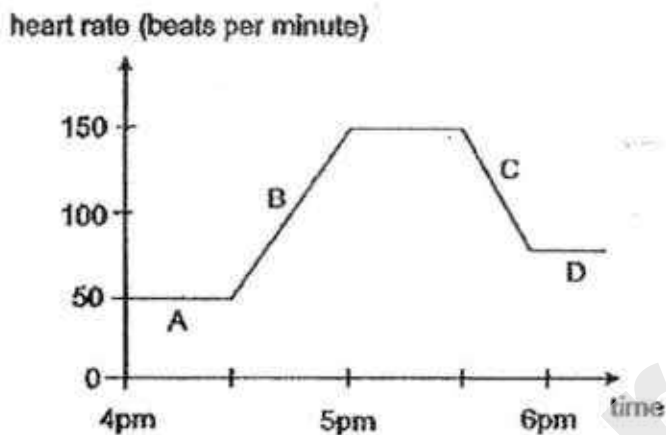

a) Match Damien's activities shown in the table below according to his heart rates at A, B, C and D in the graph above. [1]

	Activity	Write A, B, C or D
(i)	cooling down	
(ii)	sprinting	
(iii)	walking	
(iv)	at rest	

b) Explain your answer for (aii). [2]



19. The diagram below shows the flow of blood in our circulatory system.

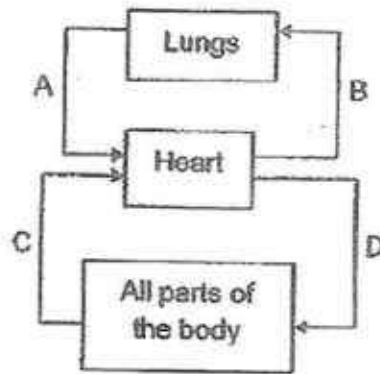

Blood samples are taken from A, B, C and D and the amount of oxygen present in each sample is recorded in the graph shown below.

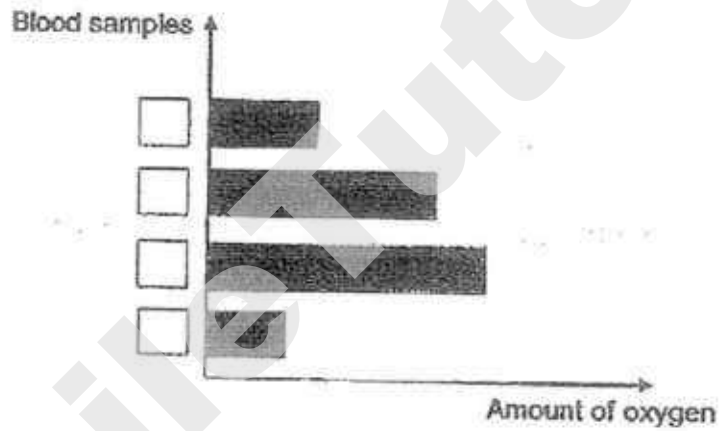

- a) In the graph above, label the blood samples by writing the letters A, B, C or D in the boxes provided. [2]
- b) Besides gases, name two other substances our blood transports in the body. [1]

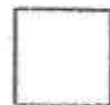

20. Lenice conducted an experiment using two inflated balloons, A and B, of the same size. She placed balloon A in a freezer and balloon B on a table at room temperature. After 45 minutes, she noticed that balloon A had shrunk but the size of balloon B remained the same. Removing balloon A from the freezer, she then left it on the same table as balloon B. After some time, she noted that balloon A had regained its original size.

a) What could have happened to result in Lenice's observations of balloon A? [2]

b) The diagram below shows some electrical cables hung between some poles beside a busy road.

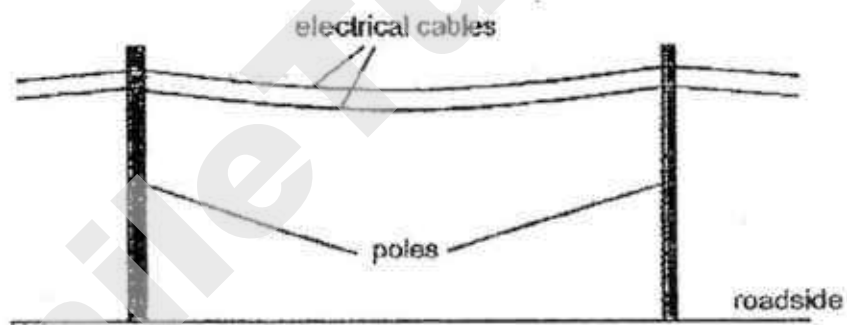

Suggest a reason why the cables are allowed to hang loosely between the poles. [1]

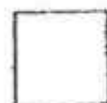

21. Harry set up an experiment as shown below. He poured some water into the flask at point A. He observed that water was able to enter the flask through the funnel smoothly.

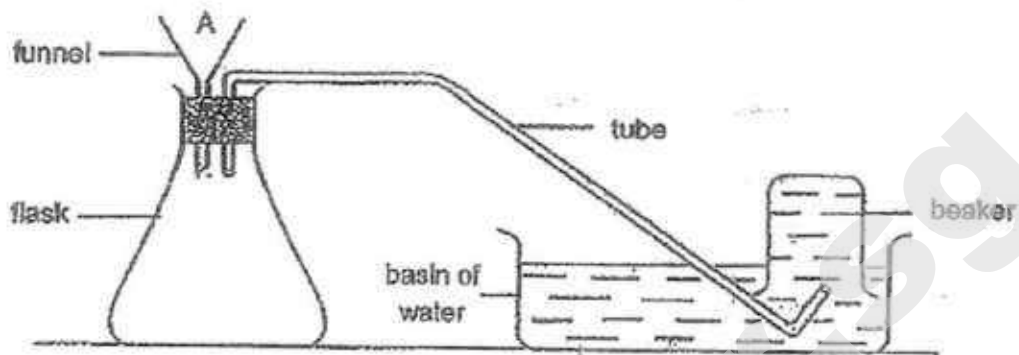

- a) As water was entering the flask through the funnel, state one other possible observation Harry would make. Give a reason for your answer.

[2]

- b) What property of air does Harry's experiment show?

[1]



22. Jessie observed that magnet M and object P were attracted as shown below.

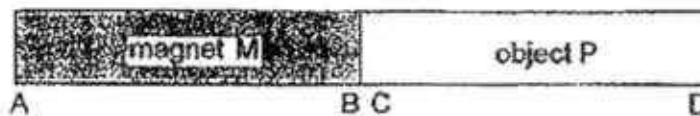

- a) Based on her observation, Jessie could not conclude whether object P is a magnet or not. Using only magnet M and object P, what should Jessie do to conclude whether object P is a magnet or not? Explain your answer. [2]

- b) Jessie placed magnet M on a table. She then placed two similar iron balls, X and Y, next to magnet M as shown below.



When she lifted magnet M, ball X remain attached to the magnet but ball Y did not. Explain why ball Y did not remain attached to the magnet. [1]

End of Paper



EXAM PAPER 2017 (P5)

SCHOOL :CHIJ ST

SUBJECT : SCIENCE

TERM : CA1

Q1	Q2	Q3	Q4	Q5	Q6	Q7	Q8	Q9	Q10
2	2	2	4	3	3	2	3	3	3
Q11	Q12	Q13	Q14	Q15					
4	1	4	1	1					

16)a)No.The roots of a plant will always grow downwards and the shoots will grow upwards even if the position is not the same.

b)The life cycle of the bean plant reproduce by seeds but the life cycle of a fern reproduce by spores.

17)a)It acts as a control set-up to show that any decrease in the water level is due to the presence of the plant's roots absorbing water.

b)

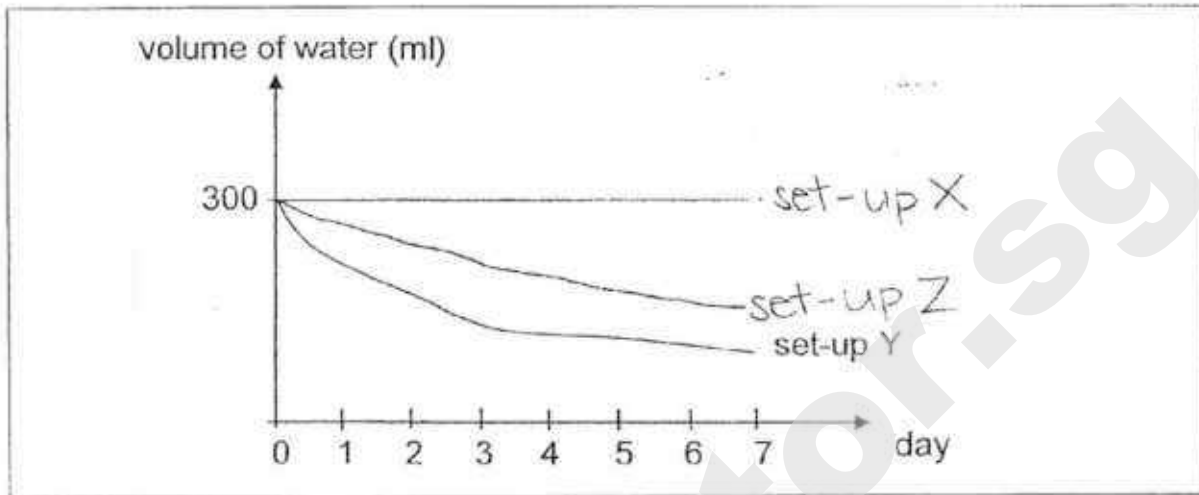

18)a)i)C

ii)B

iii)D

iv)A

b) Damien's heart rate increase as he needed more energy when he exercise. His heart pumps faster to transport more blood with oxygen and digested food for higher rate of respiration.

19)a)C

D

A

B

b) Digested food and water

20)a) When balloon A was placed in the freezer, the air in the balloon lost heat and contracted causing the balloon to shrink. When the balloon was removed from the freezer and placed on the table, the air in the balloon gained heat and expanded causing it to regain its original size.

b)When it is a cold day,the electrical cables will lose heat to its surroundings and contract and it will break if they are hung too tightly between the poles.

21)a)Bubbles will be seen coming out from the glass tube in the beaker.Water entered the flask and displaced the air into the beaker.

b)Air occupies space

22)a)She should place end D of the object P near to the magnet M.If D repels end B of the magnet,then object P is a magnet.

b)The magnet strength of the magnet is the strongest at its poles.The magnetism in the middle of Magnet M is not strong enough to attract iron ball B.



**CATHOLIC HIGH SCHOOL
CONTINUAL ASSESSMENT TWO (2017)
PRIMARY FIVE**

SCIENCE

BOOKLET A

Name: _____ ()

Class: Primary 5 - _____

Date: 24 August 2017

10 questions

20 marks

Total Time for Booklets A and B: 40 minutes

INSTRUCTIONS TO CANDIDATES

Do not turn over this page until you are told to do so.

Follow all instructions carefully.

Answer all questions.

Shade your answers in the Optical Answer Sheet (OAS) provided.

This booklet consists of 6 printed pages, excluding the cover page.

Booklet A (10 × 2 marks)

For each question from 1 to 10, four options are given. One of them is the correct answer. Make your choice (1, 2, 3 or 4). Shade your answer on the Optical Answer Sheet. (20 marks)

- 1 The diagram below shows the human respiratory system.

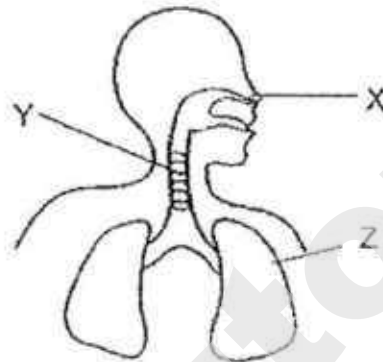

Which of the following statements is/are correct?

- A Y transports air from X to Z.
- B Only oxygen is taken in at X.
- C Gaseous exchange **does not** take place at Z.

- (1) A only
- (2) B only
- (3) C only
- (4) A, B and C

- 2 Which of the following statements are correct?

- A The air we breathe out is cooler than **the** air we breathe in.
- B The air we breathe in contains more oxygen than the air we breathe out.
- C The air we breathe in contains more water vapour than the air we breathe out.
- D The air we breathe out contains more carbon dioxide **than** the air we breathe in.

- (1) A and C only
- (2) B and D only
- (3) A, C and D only
- (4) A, B, C and D

3 The table below shows the properties of cells, X, Y and Z.

Cell part \ Cell	X	Y	Z
cytoplasm	✓	✓	✓
cell membrane	✓	✓	✓
nucleus	✓	✓	✓
cell wall	✓	✓	
chloroplasts	✓		

Some pupils made the following statements.

- A Cell X is a plant cell.
- B Cell Y is a plant cell.
- C Cell Z is an animal cell.
- D Cells X and Y can make their own food.

Which of the above statements are correct?

- (1) A and D only
- (2) B and C only
- (3) A, B and C only
- (4) A, B, C and D

4 The cell below is taken from a plant found in pond water.

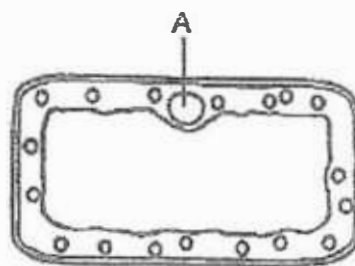

What is the function of part A?

- (1) Allows some materials to pass through.
- (2) Traps sunlight for the plant to make food.
- (3) Allows all materials and water to pass through.
- (4) Contains information that is passed from one generation to another.

- 5 Joe made a model of the human respiratory system as shown below.

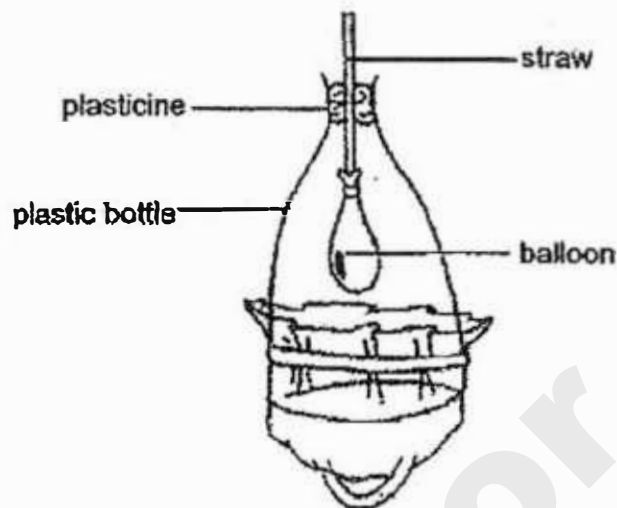

Which of the following is represented by each part of the model?

	straw	balloon	plastic bottle
(1)	nose	lung	ribcage
(2)	nose	ribcage	lung
(3)	windpipe	lung	ribcage
(4)	windpipe	ribcage	lung

- 6 A group of people was trapped in a lift for 30 minutes. There was no fresh supply of air while they were trapped inside the lift.

Which of the following about the changes in the amount of carbon dioxide, water vapour and oxygen in the lift after 30 minutes is correct?

	carbon dioxide	water vapour	oxygen
(1)	increase	increase	decrease
(2)	increase	decrease	increase
(3)	increase	increase	increase
(4)	decrease	decrease	decrease

- 7 The table below shows the comparison between how a man and a fish breathe.

	Man	Fish
A	Air containing oxygen enters through the nose or mouth and gets into the lungs.	Water containing dissolved oxygen enters through the mouth and passes over the gills.
B	Oxygen from the air gets into the blood vessels in the lungs.	Oxygen in the air gets into the blood vessels in the gills.
C	The lungs have many air sacs to allow greater gaseous exchange.	The gills have many feather-like structures with a rich supply of blood vessels.

Which of the above comparisons are correct?

- (1) A and B only
 (2) A and C only
 (3) B and C only
 (4) A, B and C
- 8 The diagram below shows the different body systems in the human body.

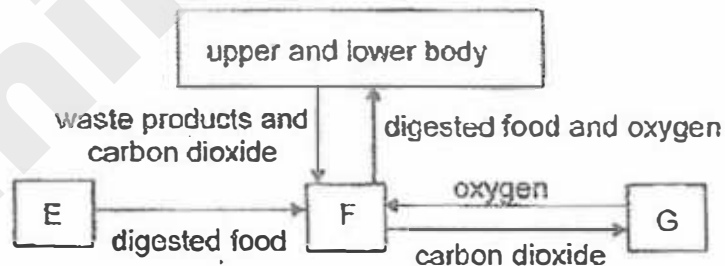

Which of the following correctly represents E, F and G?

	E	F	G
(1)	respiratory	circulatory	digestive
(2)	digestive	respiratory	circulatory
(3)	circulatory	digestive	respiratory
(4)	digestive	circulatory	respiratory

- 9 Kai Lung plucked a leaf from a plant and placed it in a beaker of hot water.

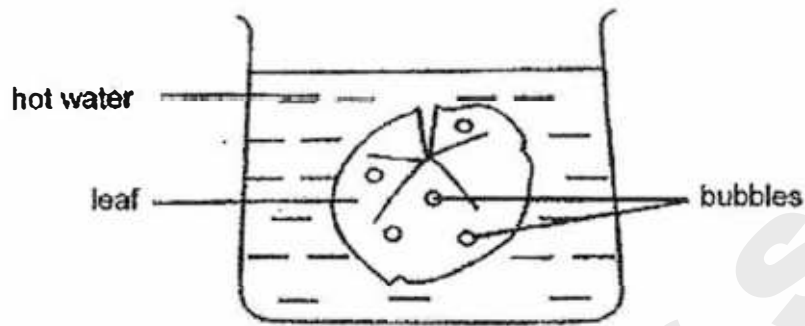

He observed that bubbles formed only on the upper surface of the leaf.

Which one of the following statements is correct?

- (1) Bubbles form in the water and land on the upper surface of the leaf.
- (2) Air escapes through tiny openings found on both surfaces of the leaf.
- (3) The leaf has tiny openings on the upper surface but not on the lower surface.
- (4) Air enters the lower surface of the leaf and escapes through the upper surface.

10 Sue plotted a graph to show her heart rate as she walked, ran and rested

Which graph shows her correct heart rate as she walked, ran and rested?

(1)

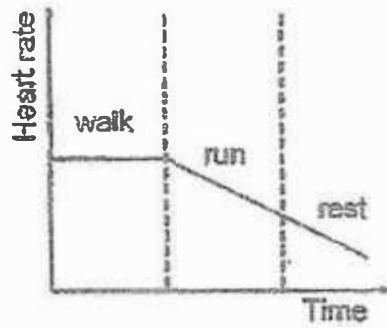

(2)

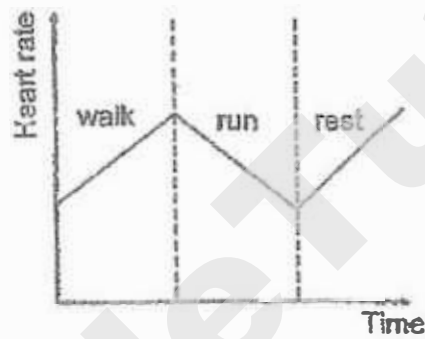

(3)

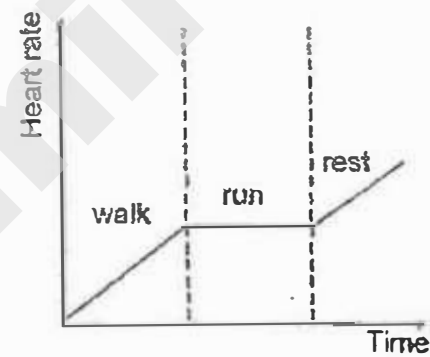

(4)

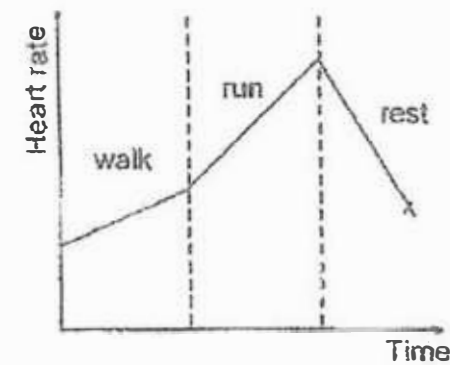

End of Booklet A

**CONTINUAL ASSESSMENT TWO
(2017) PRIMARY FIVE**

SCIENCE

BOOKLET B

Name: _____ ()

Class: Primary 5 - _____

Date: 24 August 2017

Parent's Signature: _____

5 questions

15 marks

Booklet A	20
Booklet B	15
Total	35

Total Time for Booklets A and B: 40 minutes

INSTRUCTIONS TO CANDIDATES

Do not turn over this page until you are told to do so.

Follow all instructions carefully.

Answer all questions.

Write your answers in this booklet.

This booklet consists of 5 printed pages, excluding the cover page.

Booklet B (15 marks)

For questions 11 to 15, write your answers in this booklet.

The number of marks available is shown in brackets [] at the end of each question or part question. (15 marks)

- 11 Ben inserted a tube with a coloured oil droplet into a test-tube that prevented air from going in and out of the tube.

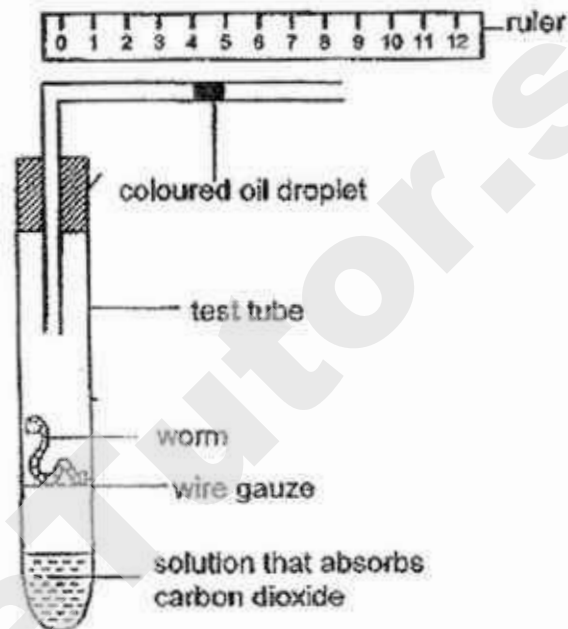

- (a) Will the coloured droplet move towards or away from the test-tube after a few hours? Explain your answer. [2]

- (b) Name a gas inside the test-tube that remained the same in amount throughout the experiment. [1]

(Go on to the next page)

SCORE	3
-------	---

- 12 The diagram below shows the direction of blood flow in some parts of the human body.

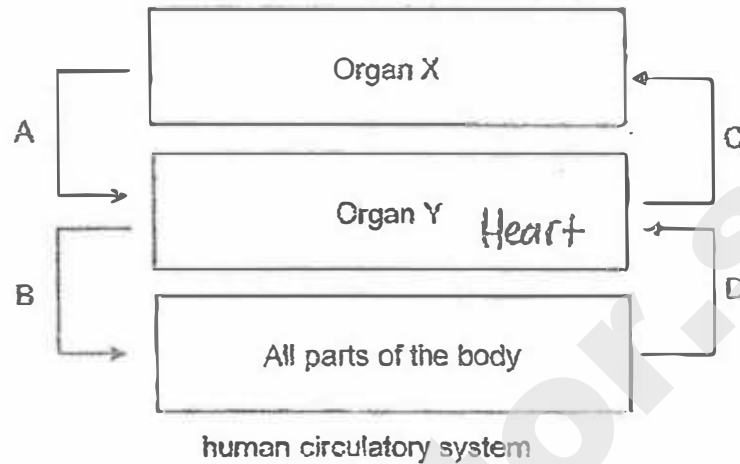

- (a) Name the organs X and Y. [1]

Organ X: _____

Organ Y: _____

- (b) Other than the direction of flow, state one difference between blood in A and blood in C. [1]

- (c) Name one substance in the blood where its amount is higher in D than B. [1]

(Go on to the next page)

SCORE	3
-------	---

13 Look at the diagram of the respiratory system shown below.

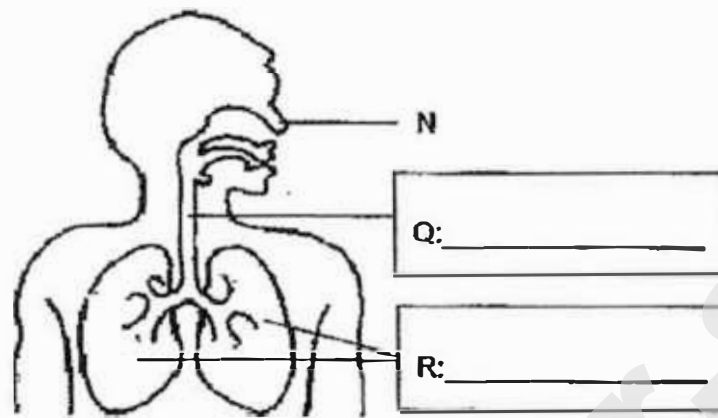

(a) Identify the parts Q and R. Write their names in the boxes above. [1]

(b) What is the function of the hair found in part N? [1]

(Go on to the next page)

SCORE	2
-------	---

14 The diagrams below show two cells from different plants.

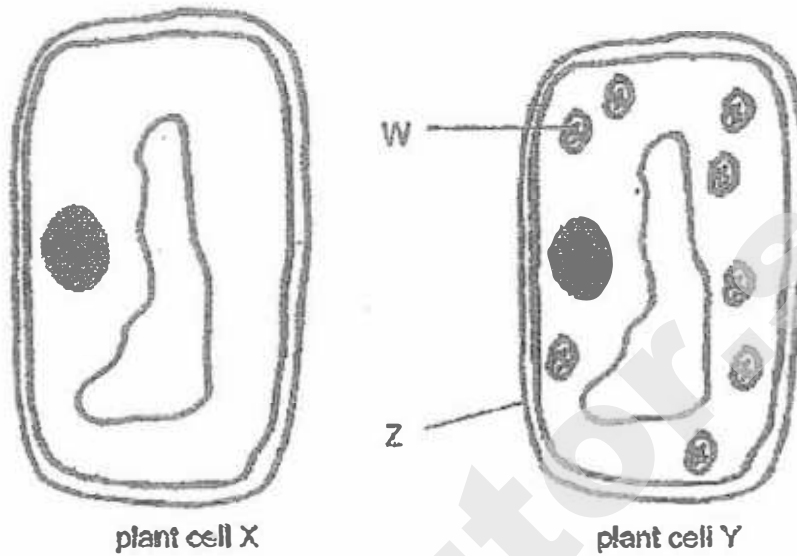

(a) Which cell part is found in both plant cells X and Y but not in animal cells? [1]

(b) What would happen if part Z is absent in plant cell Y? [1]

(c) What is the function of the part labelled W? [1]

(Go on to the next page)

SCORE	3
-------	---

15 The table below shows Ali's breathing and pulse rate according to age.

Age (years)	Breathing rate (average number of times per minute)	Pulse Rate (average number of beats per minute)
10	22	110
20	18	85
30	16	75
40	14	70
50	12	65

(a) What is the relationship between the age and breathing rate per minute? [1]

(b) Why does Ali's breathing rate increase when he is running? [1]

(c) Explain why Ali's heart beats faster after running for 10 minutes. [2]

SCORE	4
-------	---

End of Booklet B

YEAR : 2017
LEVEL : P5
SCHOOL : CATHOLIC HIGH SCHOOL
SUBJECT : SCIENCE
TERM : CA2

Booklet A

Q1	1	Q2	2	Q3	3	Q4	4	Q5	3
Q6	1	Q7	2	Q8	4	Q9	3	Q10	4

Booklet B

Q11 (a) Towards the test tube. The worm takes in oxygen in the test tube and produces carbon dioxide. The released carbon dioxide is absorbed by the solution so the oil droplet moves inner to occupy the space.

(b) Nitrogen.

Q12 (a) Organ X: Lung Organ Y: Heart

(b) Blood in A is richer in oxygen than the blood in C.

(c) Carbon dioxide.

Q13 (a) Q: Windpipe
R: Lung

(b) the hair in part N is to trap tinny dust particles from the air that we breathe in.

Q14 (a) Cell wall.

(b) Plant cell Y would not have support and shape.

(c) It contains chlorophyll to trap sunlight for the plant to make food.

Q15 (a) The greater the age of the person, the lower the breathing rate per minute.

(b) He needs to breathe harder to take in more oxygen and remove more carbon dioxide from his body.

(c) After running for 10 minutes, his body need more energy to compensate for the lost energy. Thus, his heart beats faster as it needs to pump more oxygen and digested food to the rest of his body.

Pei Chun Public School
Continual Assessment – 2017
Science
Primary 5

Name : _____ ()

Date : 22 August 2017

Class : Pri. 5 ()

Science Teacher : _____

Time : 1 h 45 min

Section A (28 × 2 marks)

For questions 1 to 28, choose the most suitable answer and shade its number (1, 2, 3 or 4) on the Optical Answer Sheet (OAS) provided.

1. Study the flowchart given below.

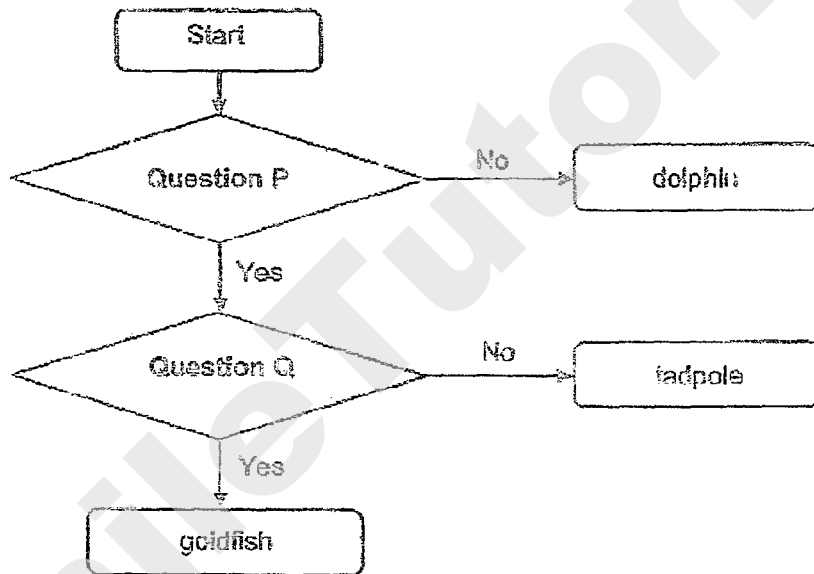

Which of the following is correct?

	Question P	Question Q
(1)	Does it have gills?	Does it have scales?
(2)	Does it have scales?	Does it have gills?
(3)	Is it a fish?	Does it have scales?
(4)	Is it a fish?	Does it have gills?

2. The diagram below shows a cooking pot with a handle.

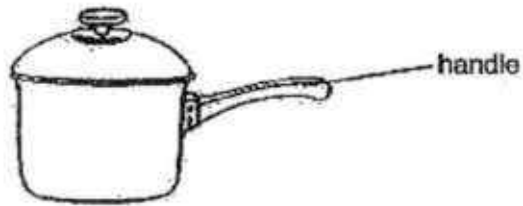

Study the properties of the four materials shown below.

Material	Property of material	
	Does it bend easily?	Does it conduct heat easily?
A	yes	yes
B	yes	no
C	no	yes
D	no	no

Which material is most suitable for making the handle?

- (1) A
- (2) B
- (3) C
- (4) D

3. Mandy constructed three electromagnets with identical batteries and iron rods as shown below.

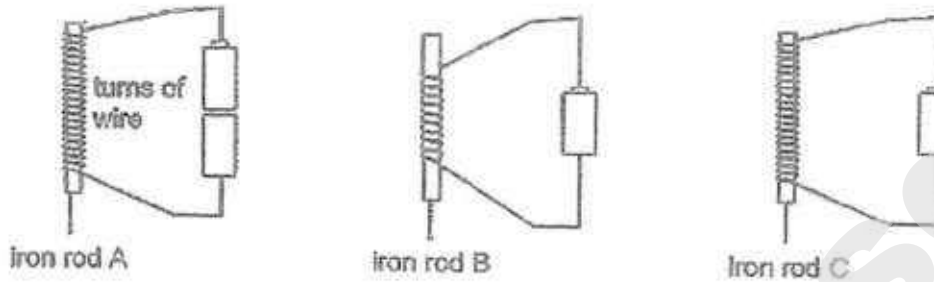

She placed each of the iron rods an equal distance away from a tray of identical steel pins and counted the number of steel pins attracted by the iron rods.

Which of the graphs correctly shows the results of her experiment?

(1)
Number
of pins
attracted

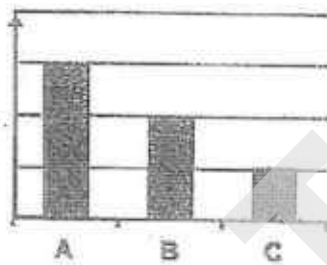

(2)
Number
of pins
attracted

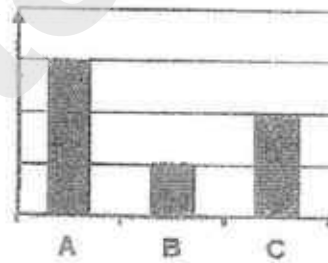

(3)
Number
of pins
attracted

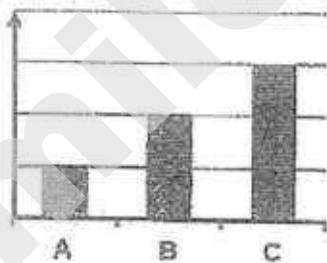

(4)
Number
of pins
attracted

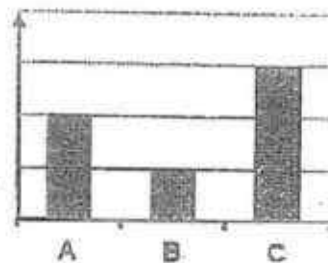

4. A metal bar, PQ, is freely suspended on a piece of string. It was spun and it came to rest with one end of the bar pointing to the North. It was spun a second time and again, the same end of the bar came to rest pointing to the North.

Another bar RS, made of the same metal, was also freely suspended and then spun a few times. However, the bar came to rest in no particular direction each time after it had been spun.

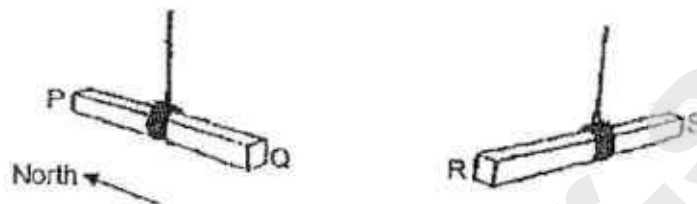

What would most likely happen if the two bars are brought near to each other?

- (1) End P attracts S but repels R.
 - (2) End P repels S but attracts R.
 - (3) End P attracts neither S nor R.
 - (4) Both ends P and Q attracts end S.
5. The diagram below shows the human digestive system.

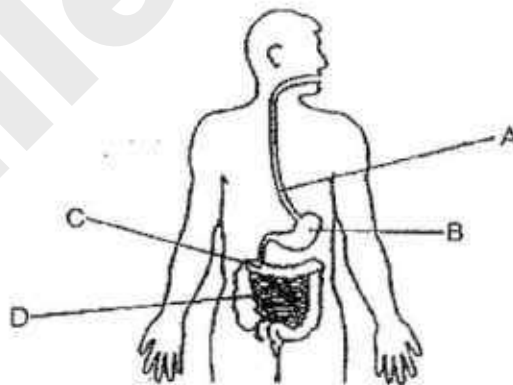

At which part is digested food absorbed into the bloodstream?

- (1) A
- (2) B
- (3) C
- (4) D

6. Sue filled a syringe with gas Y.

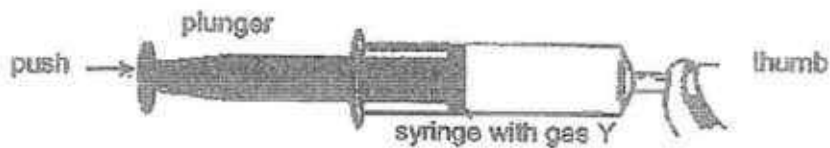

She pushed the plunger in as hard as she could.

How would the volume and mass of gas Y be affected by the pushing of the plunger?

	volume	mass
(1)	decrease	decrease
(2)	decrease	unchanged
(3)	unchanged	decrease
(4)	unchanged	unchanged

7. Ahmad placed three objects, J, K and L, into three identical beakers as shown below. He added water to each of the beakers and the water levels in the three beakers were the same.

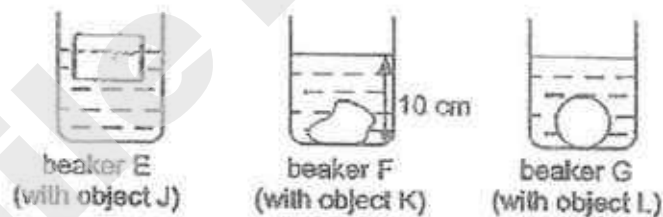

He removed the objects from the water. The diagram below shows the water level in the three beakers.

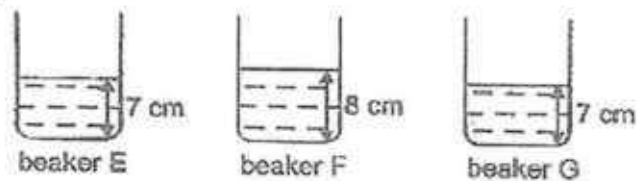

Which of the following shows the correct order of the objects starting from the smallest volume to the greatest volume?

- (1) K , J , L
- (2) K , L , J
- (3) J , L , K
- (4) L , J , K

8. The diagram shows the life cycle of a butterfly.

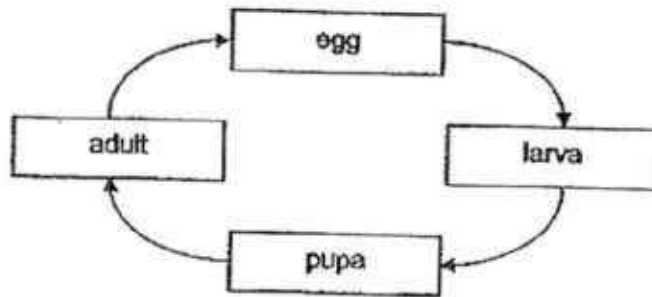

Which of the following graphs correctly represents the mass of the butterfly during its stages of the life cycle?

(1)

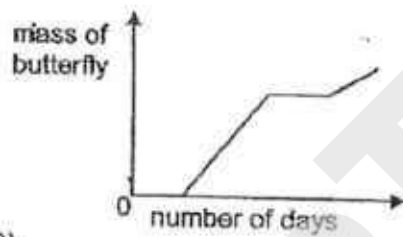

(2)

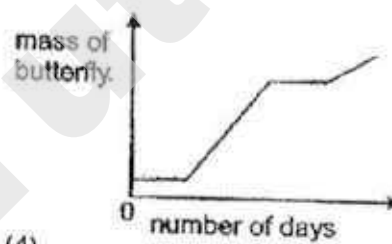

(3)

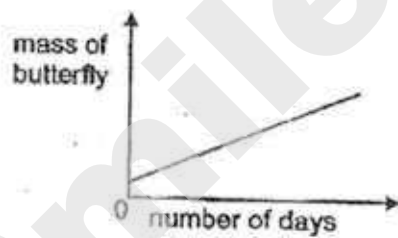

(4)

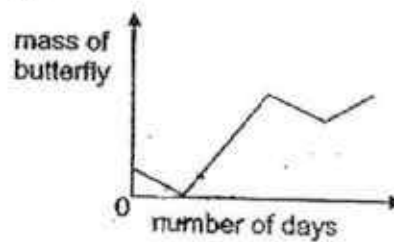

9. Maya wanted to find out how much light can pass through three materials, A, B and C, by using the set-up shown below. The amount of light detected by the sensor was recorded. She conducted the experiment in a dark room.

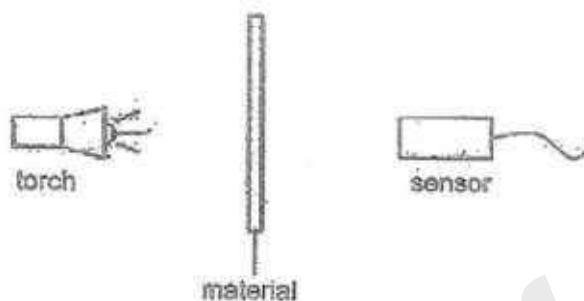

The results of the experiment are shown in the table below.

Type of material	Amount of light detected (units)
Without material	5000
A	0
B	4900
C	2500

Which type of glass is most suitable to make the lens of a pair of reading glasses and a pair of sunglasses?

	Reading glasses	Sunglasses
(1)	C	A
(2)	B	A
(3)	B	C
(4)	C	B

10. A glass containing a block of ice and some water was placed in a room. The room temperature was 25°C .

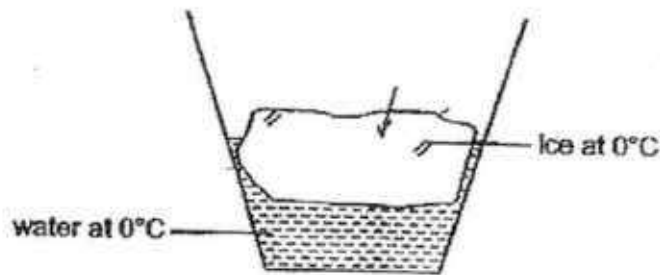

When the ice and the water were at 0°C , which of the following statements is correct?

- (1) The ice would not melt as it remained at 0°C .
 - (2) The ice would not melt as it did not gain heat.
 - (3) The ice would melt as it gained heat from the water.
 - (4) The ice would melt as it gained heat from the surrounding air.
11. Bala conducted an experiment with a datalogger and two temperature sensors, P and Q. The ends of the sensors were covered with cloth.

P was kept dry. Q was dipped in water at room temperature for 2 seconds and then taken out.

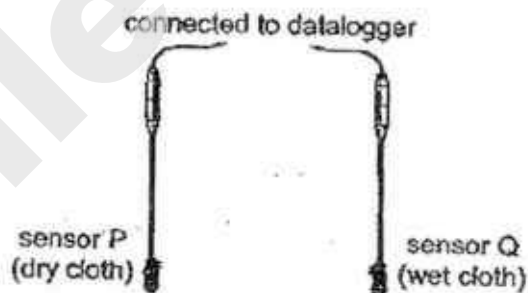

Every five minutes, the datalogger recorded the temperatures of the sensors and the results are shown in the table below.

Time (min)	0	5	10	15
Temperature of sensor P ($^{\circ}\text{C}$)	25	25	25	25
Temperature of sensor Q ($^{\circ}\text{C}$)	25	23	22	22

The temperature of sensor Q was lower than room temperature because _____.

- (1) water was evaporating from the wet cloth
- (2) the wet cloth conducted heat to the sensor
- (3) water vapour was condensing on the wet cloth
- (4) the wet cloth acted as a poor conductor of heat

12. Cassandra wanted to give her mother an orange flower. She bought a stalk of white flower and cut the stalk into two before placing the stalk of flower into two beakers as shown in the diagram below.

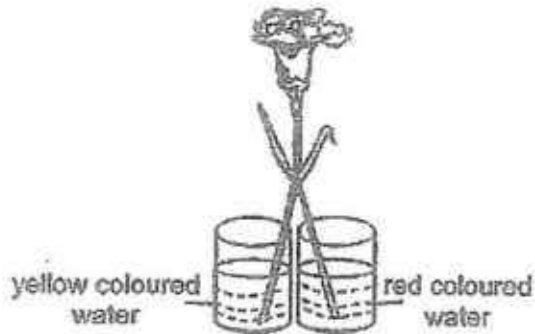

Cassandra learnt that mixing yellow and red will produce orange.
Will she obtain an orange flower at the end of the experiment? Why?

		Reason
(1)	Yes	Water in the water-carrying tubes will combine in the stem.
(2)	Yes	The colourings will be mixed when they reach the white flower.
(3)	No	The two coloured water are carried by separate water-carrying tubes so the food colourings do not mix.
(4)	No	The roots have been removed. Roots take in water for the plant.

13. Stomata are tiny openings found mostly on the underside of leaves. These openings allow for gaseous exchange. The size of the stomata of plant X changes throughout the day as shown in the table below.

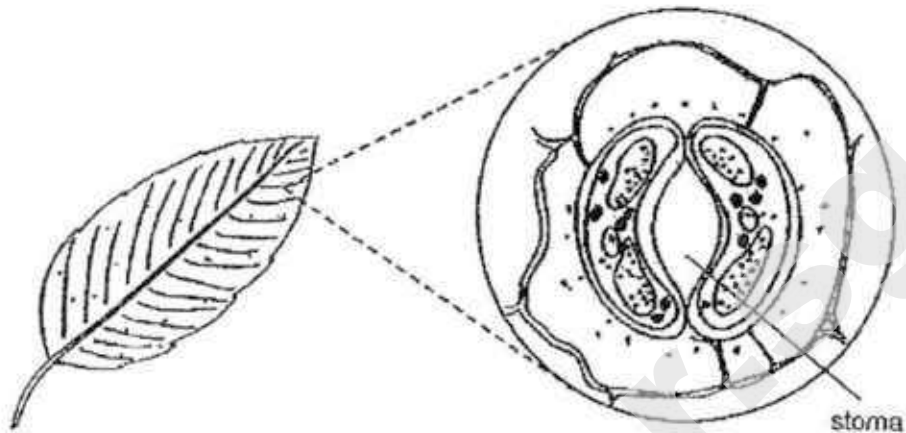

Time	Average size of stomata (units)
5 a.m.	1
11 a.m.	5
3 p.m.	5
8 p.m.	1

Which of the following explains why the stomata changes in size?

- (1) The size of the stomata increases to allow more sunlight to enter the plant for photosynthesis.
- (2) The size of the stomata increases to allow more carbon dioxide to enter the plant for photosynthesis.
- (3) The size of the stomata decreases to allow less carbon dioxide to enter the plant for it to produce energy.
- (4) The size of the stomata decreases to allow more oxygen to enter the plant for it to produce energy.

14. The diagram below shows the heart with its main blood vessels, A, B, C and D.

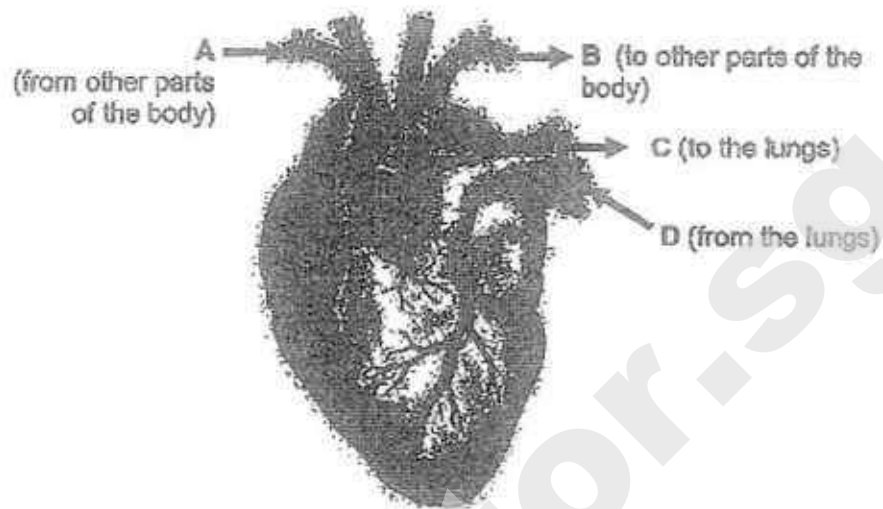

Which of the blood vessels carry blood that is rich in oxygen?

- (1) A and C
 (2) A and D
 (3) B and C
 (4) B and D
15. Study the classification table below.

Circulatory System	Respiratory System
lungs	nose
heart	gullet
blood	blood vessels

Which of the following have been wrongly classified?

- A : heart
 B : lungs
 C : gullet
 D : blood vessels
- (1) A and B
 (2) C and D
 (3) A, C and D only
 (4) B, C and D only

16. The diagram below can be used to identify parts, V, W, X, Y and Z, of a cell.

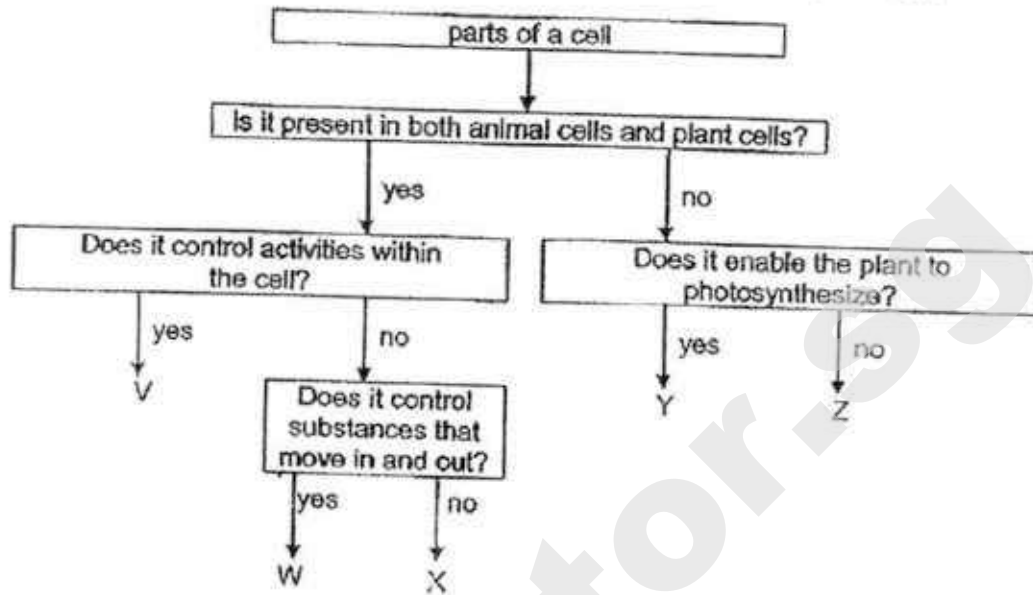

Which of the following correctly represent parts V, W, X, Y and Z?

	V	W	X	Y	Z
(1)	nucleus	chloroplasts	cytoplasm	cell membrane	cell wall
(2)	cytoplasm	nucleus	cell membrane	chloroplasts	cell wall
(3)	cytoplasm	cell membrane	chloroplasts	cell wall	nucleus
(4)	nucleus	cell membrane	cytoplasm	chloroplasts	cell wall

17. Halim observed the following cell under a microscope for a few minutes and concluded that it is an animal cell.

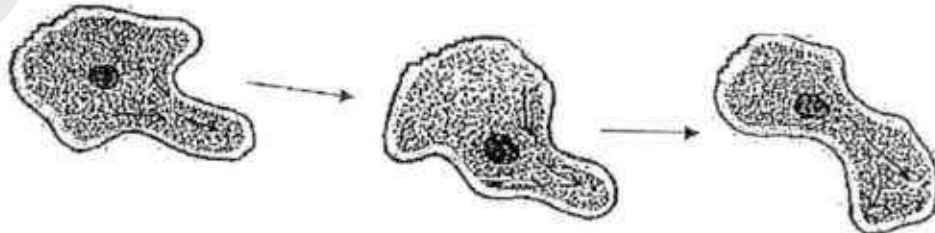

Based on the diagram above, what characteristic of the cell led Halim to make his conclusion?

- (1) It has a cell wall.
- (2) It has a nucleus.
- (3) It has a cell membrane.
- (4) It is of an irregular shape.

18. The diagram below shows two puppies and their parents.

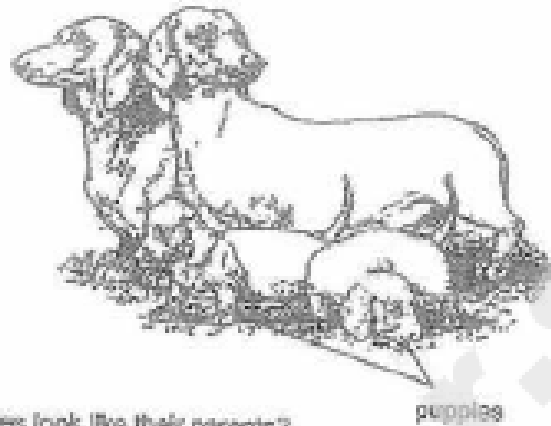

Why do the puppies look like their parents?

- A : Genetic information was passed from the mother in an egg.
- B : Genetic information was passed from the father in a sperm.
- C : Genetic information was passed from the mother in her milk.
- D : Genetic information was passed from the mother in the blood.

- (1) A only
- (2) D only
- (3) B and C only
- (4) A and B only

19. Jing Ting conducted an experiment to find out the conditions required for germination of seeds.

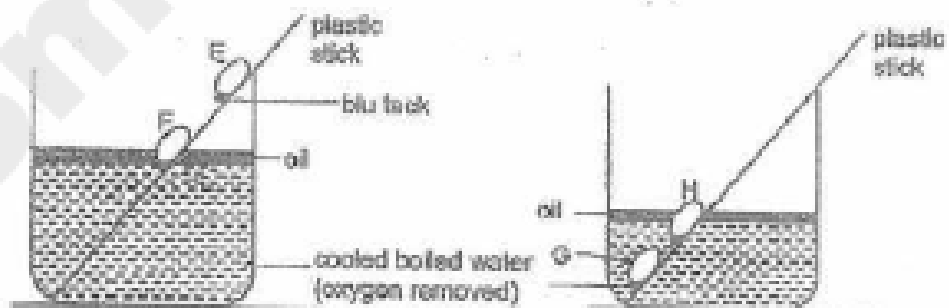

Which seed would most likely germinate?

- (1) E
- (2) F
- (3) G
- (4) H

20. The diagrams below show three fruits, P, Q and R.

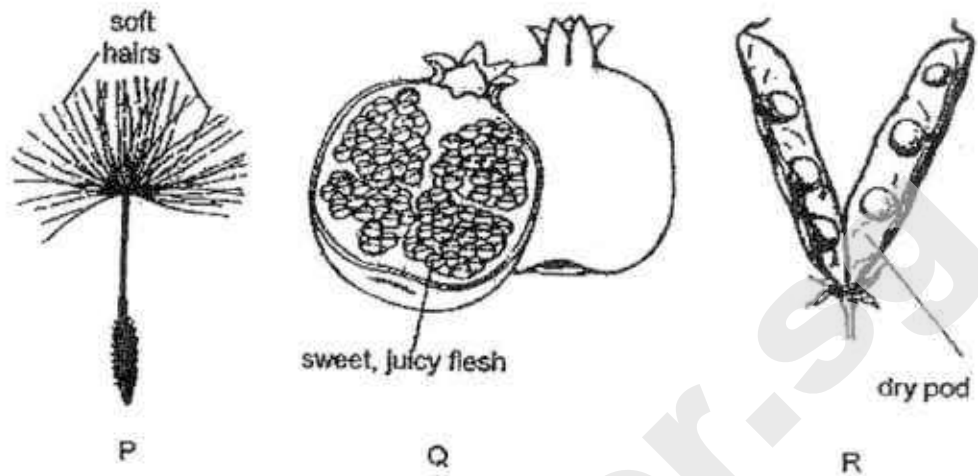

Which of the following correctly matches the methods of dispersal of P, Q and R?

	P	Q	R
(1)	animal	wind	splitting of fruit
(2)	animal	water	wind
(3)	wind	animal	splitting of fruit
(4)	wind	animal	water

21. The diagram below shows the reproductive parts of a human and a plant, respectively.

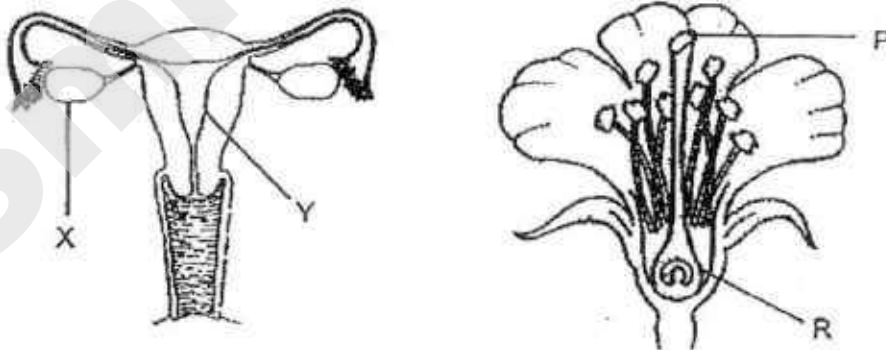

Based on the diagrams, which are the parts that contain the female reproductive cells?

- (1) P and X
- (2) P and Y
- (3) R and X
- (4) R and Y

22. The table below shows the states of three different substances, W, X and Y, at various temperatures.

Substance	State of substance at		
	35 °C	50 °C	75 °C
W	solid	solid	liquid
X	solid	liquid	gas
Y	solid	solid	solid

Which of the following statements is/are definitely true?

- A : W boils at 75 °C.
 B : X is a solid at 40 °C.
 C : Y has the highest freezing point.

- (1) C only
 (2) A and B only
 (3) B and C only
 (4) A, B and C

23. The diagram below shows a developing baby and the movement of blood in and out of the baby through the umbilical cord.

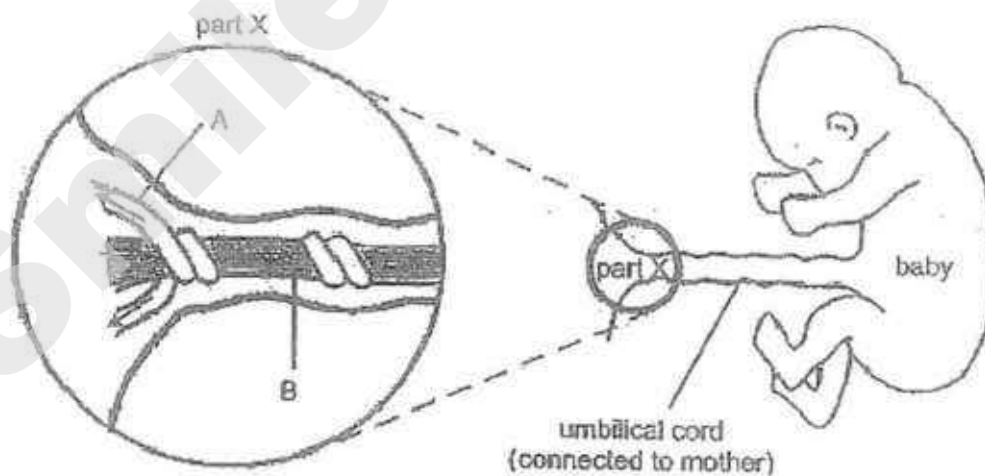

Which of the following about the blood in blood vessels A and B is correct?

	A	B
(1)	rich in oxygen	rich in digested food
(2)	rich in oxygen	poor in digested food
(3)	poor in oxygen	rich in digested food
(4)	poor in oxygen	poor in digested food

24. Shanti placed the following set up below in her room at the temperature of 27 °C.

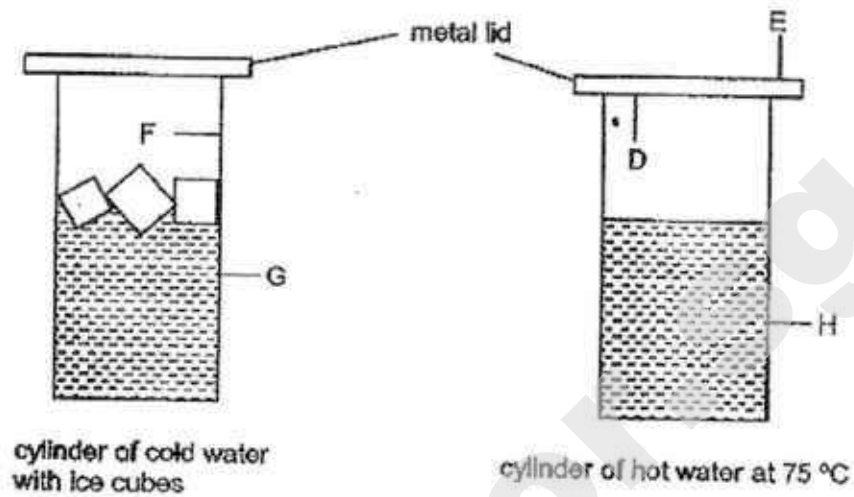

Key:

D – inner surface of metal lid
E – outer surface of metal lid

F – inner surface of cylinder
G, H – outer surface of cylinder

On which of the following surfaces, D, E, F or G, would Shanti observe water droplets after a few minutes?

- (1) G only
- (2) D and G only
- (3) D, G and H only
- (4) E, F and H only

25. The diagram below shows the water cycle.

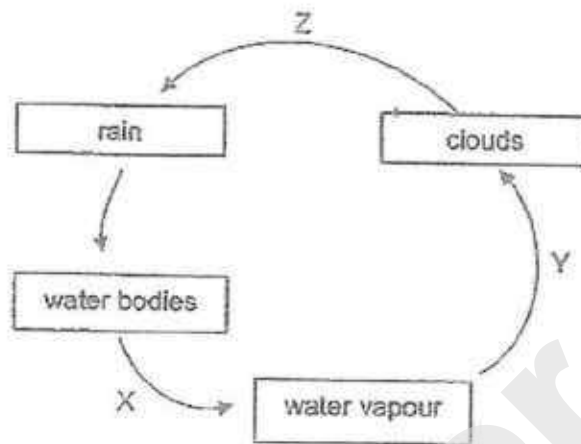

Which of the following is correct?

	Evaporation occurs at	Condensation occurs at
(1)	X	Z
(2)	X	Y
(3)	Y	Z
(4)	Y	X

26. Barissa set up two electrical circuits with four light bulbs, Q, R, S and T. The batteries and bulbs were in good working condition.

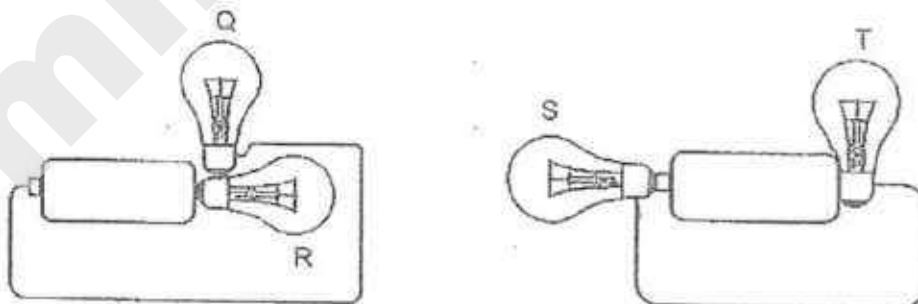

Which of the following correctly shows what she would observe?

	Bulbs that lit up	Bulbs that did not light up
(1)	Q and S	R and T
(2)	Q and R	S and T
(3)	Q, R and S	T
(4)	Q, R, S and T	none

27. Jun Jie wanted to investigate if the arrangement of the bulbs in a circuit affects their brightness. He set up four circuits, A, B, C and D, as shown in the diagrams below.

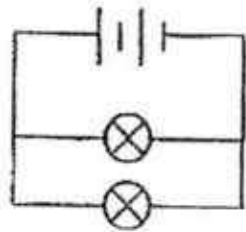

circuit A

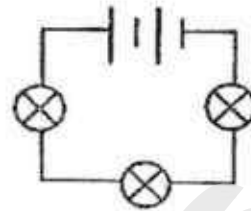

circuit B

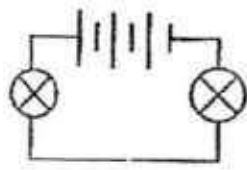

circuit C

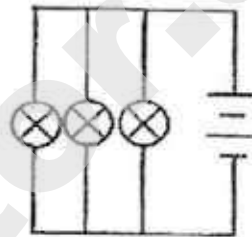

circuit D

Which two circuits should he use in his investigation to ensure a fair test?

- (1) A and B
- (2) A and C
- (3) A and D
- (4) B and D

28. Samuel made a circuit card. He tested his circuit card with a circuit tester.

The results of his test are shown below.

Clips tested	Did the bulb in the circuit light up?
P and Q	No
Q and R	Yes
P and S	Yes
P and T	Yes

Which of the following shows the correct connection on Samuel's card?

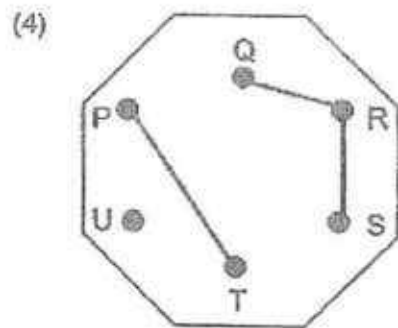
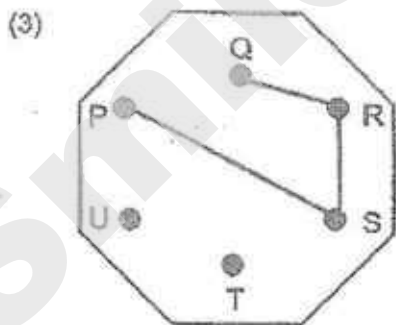
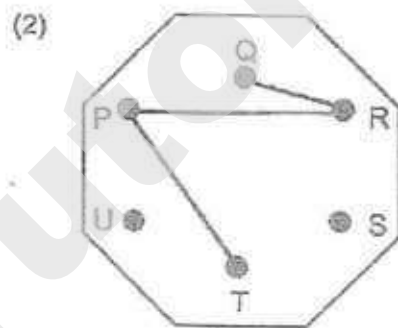
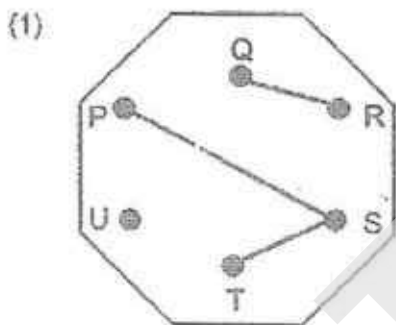

End of Section A

Continual Assessment – 2017
Science
Primary 5

Name : _____ ()

Class : Pri. 5 ()

Date : 22 August 2017

Time : 1 h 45 min

Science Teacher : _____

Parent's Signature: _____

Section A	56
Section B	44
Total	100

Section B (44 marks)

For questions 29 to 41, write your answers in the spaces provided.

29. The statements below describe the different stages in the process of fertilisation of the human female reproduction system.

- A: The nucleus of the sperm fuses with the nucleus of the egg.
- B: Many sperms reach the egg.
- C: The fertilized egg starts to divide.
- D: One sperm enters the egg successfully.

a) Arrange the above stages of fertilisation in the correct order in the boxes below. [1]

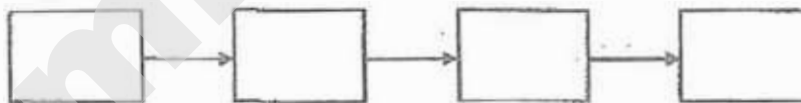

b) Study the diagram below.

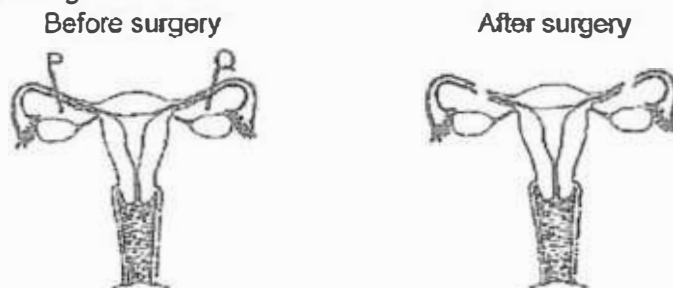

Part of the tubes at positions P and Q were removed in a female body during a surgery. Fertilisation of the eggs could not take place naturally in the female body after this surgery. Explain why this is so. [1]

SCORE	
-------	--

30. Raymond hung three identical bar magnets above a tray of identical steel pins. His observation is shown below.

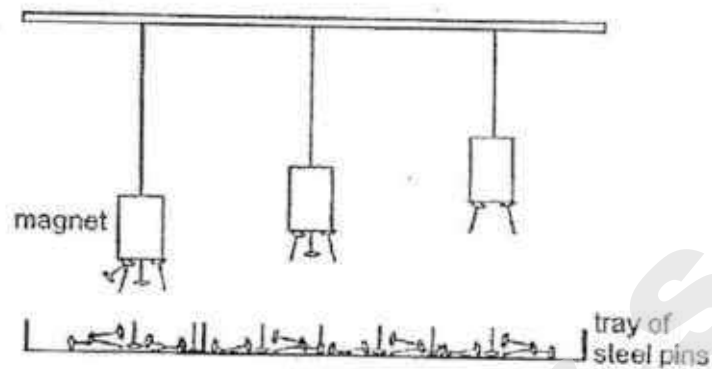

- a) Based on his observation, state how the magnetic attraction of a magnet is affected by its distance from the pins. [1]

- b) Raymond lowered a ring magnet on to a tray of steel pins as shown in diagram 1. Diagram 2 shows the bottom view of the ring magnet.

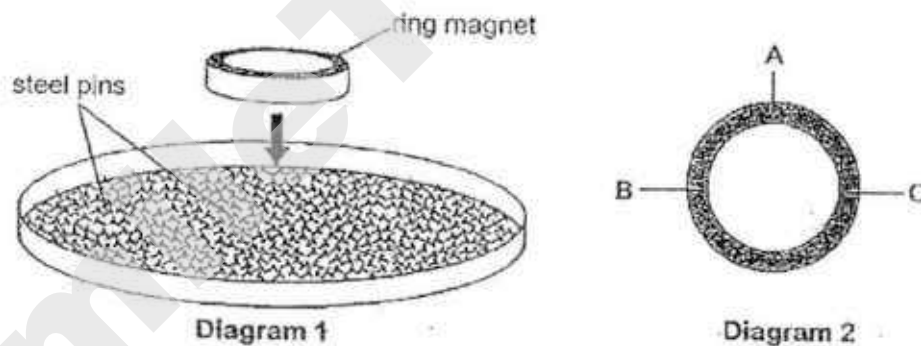

A total of 18 pins were attracted to the bottom of the magnet at positions A, B and C. Raymond's friends, Alan and Muthu, predicted the number of pins attracted at the three positions. Their predictions are shown below.

Alan's prediction:

Positions	A	B	C
Number of pins attracted	9	0	9

Muthu's prediction:

Positions	A	B	C
Number of pins attracted	6	6	6

Whose prediction, Alan's or Muthu's, is most likely to be correct? Give a reason for your answer.

[1]

SCORE	
-------	--

- c) Raymond placed two ring magnets, P and Q, through a plastic pole as shown in the diagram below.

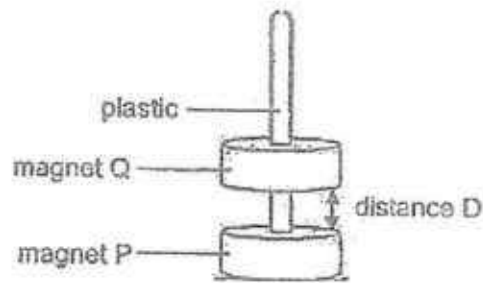

Raymond observed that magnet Q was suspended in the air. Explain why magnet Q was not touching magnet P.

[1]

- d) Raymond pushed magnet Q towards magnet P. He found that he needed to push harder as distance D decreased. Explain why.

[1]

- e) Raymond measured the distance D between magnet P and Q. Then, he placed magnet S on top of magnet Q.

Magnet Q was still suspended in the air as shown in the diagram below.

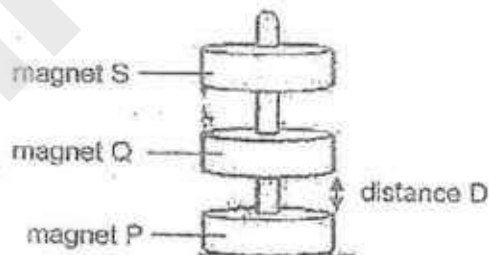

He observed that distance D decreased when magnet S was placed on top of magnet Q. Explain his observations.

[1]

31. Brian carried out an experiment on rod P using the set-up shown below. He measured distance x , at the middle of the rod after adding each mass.

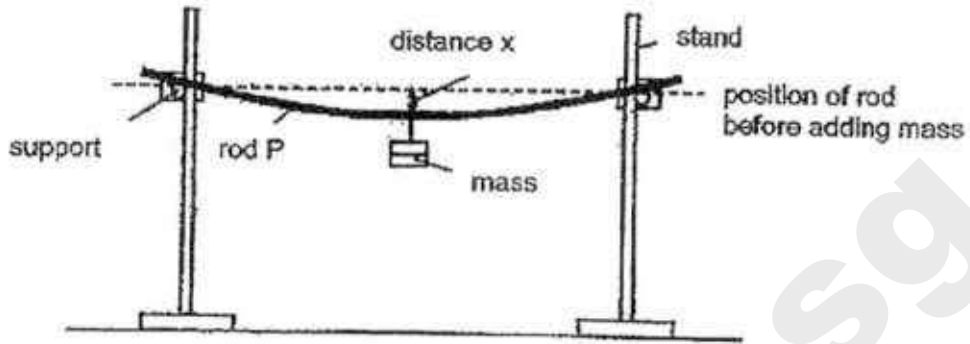

He repeated the experiment using rods Q and R of different materials but the same length. His results are shown below.

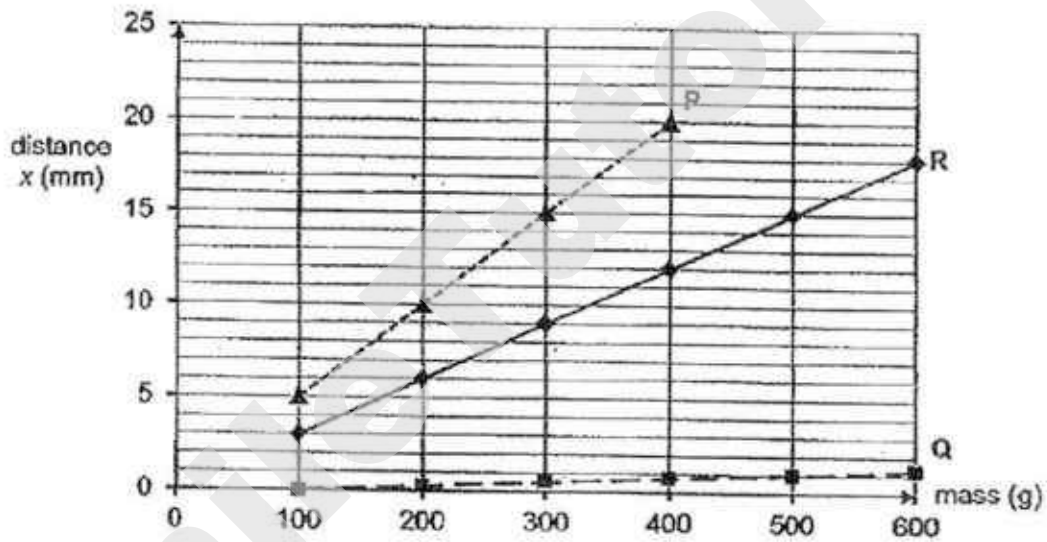

- a) What was distance x before any mass was added to the rods? [1]
-
- b) Give a reason why Brian was not able to obtain a reading for rod P when the mass hung was more than 400 g. [1]
-
- c) Based on his results, which rod, Q or R, is more suitable for making chopsticks? Explain your answer. [1]
-

SCORE	
-------	--

32. Jerry set up a light source and a light sensor to count the number of rubber balls going through a hole as shown.

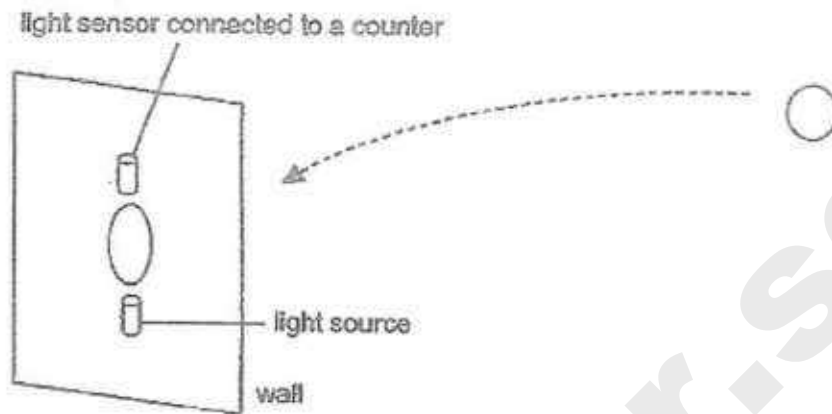

Jerry threw a few identical balls one at a time, and recorded the following results.

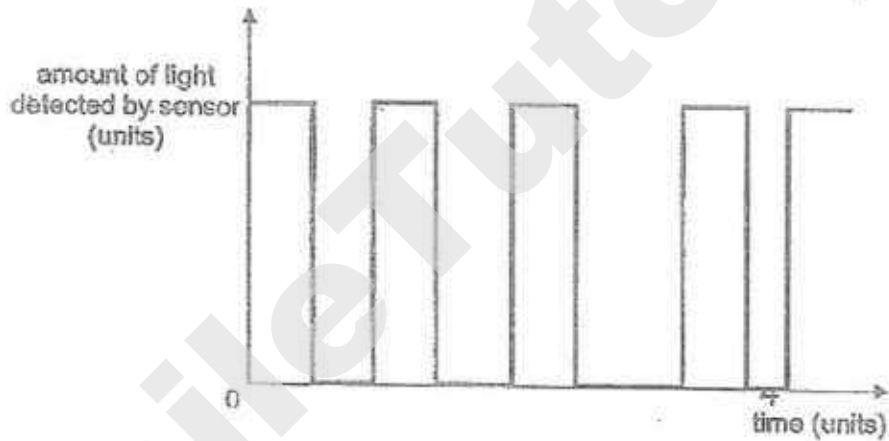

- a) Explain how Jerry could count the number of balls going through the hole using the set-up. [2]

- b) Based on the above results, how many balls went through the hole? [1]

- c) Based on the above results, did all the balls go through the hole at the same speed? Explain your answer. [1]

SCORE	
-------	--

33. Matthew conducted an experiment using the set-up shown below.

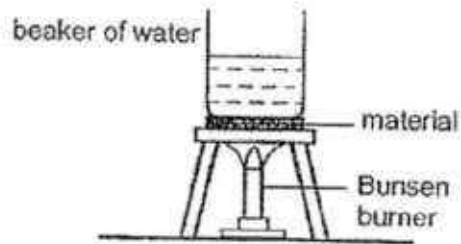

He recorded the time taken for the water to boil when different materials, X, Y and Z, were placed below the beaker of water in the table below. The pieces of materials are of the same thickness and size. Beakers P, Q and R are identical beakers and the materials were heated with identical heat sources from below.

Material	Beaker	Amount of water in the beaker (ml)	Time taken for the water to start boiling (min)
X	P	100	12
Y	Q	200	18
Z	R	300	10

- a) Based on his results, can you conclude which material, X, Y or Z, is the poorest conductor of heat? Explain why.

[2]

- b) Matthew wanted to conduct another experiment to find out if the area of contact between the metal plate and the beaker would affect the amount of heat conducted to the water. He heated identical beakers with the same amount of water of different temperatures with identical heat sources.

The diagram below shows the set-ups at the start of the experiment.

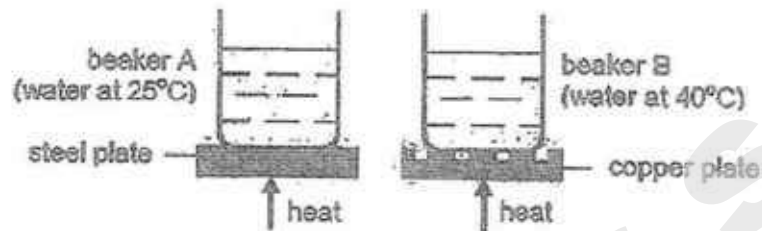

His experiment was not a fair test.

Suggest two changes to his set-up so that his experiment would be a fair one. [2]

Suggestion (1): _____

Suggestion (2): _____

34. The diagram below shows part of an air sac and a blood vessel in a lung. The arrows indicate the direction of movement of gases S and T to and from the air sac.

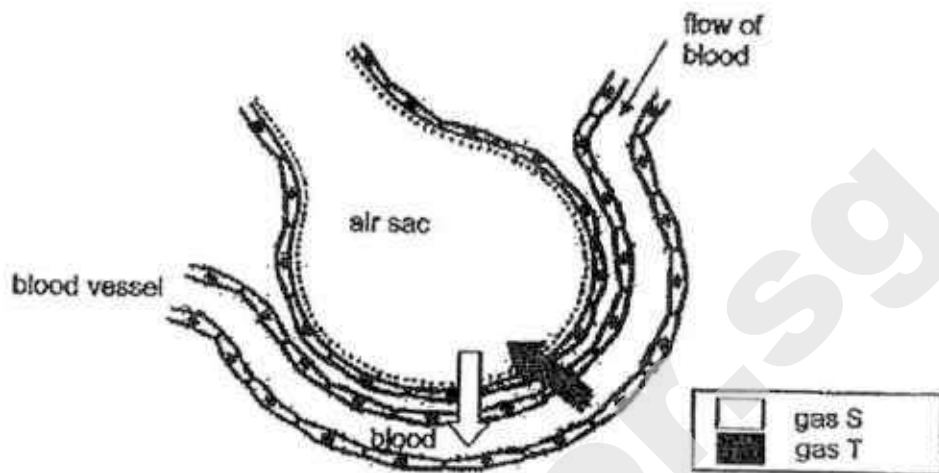

- a) What could gases S and T be?

[2]

S: _____

T: _____

The diagram below shows a human respiratory system.

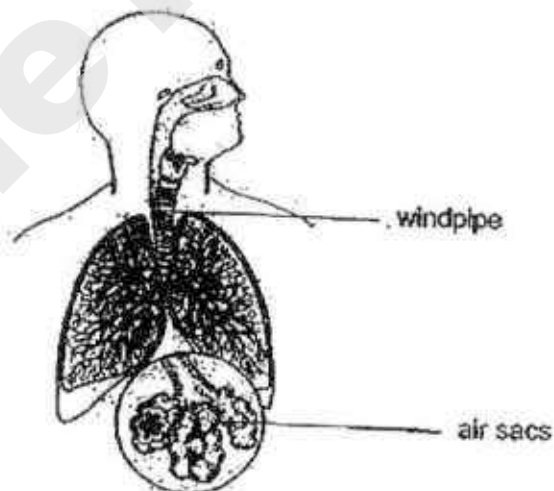

In the lungs, the air tubes branch into tiny tubes that end in air sacs with lots of blood vessels.

- b) Explain how having so many of these blood vessels help more gas S to be absorbed into the blood.

[1]

SCORE	
-------	--

- c) John made a lung model as shown below.

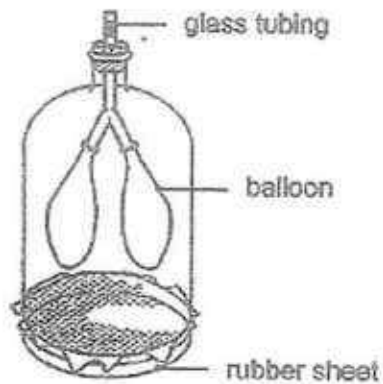

What change would you observe in the balloons when the rubber sheet is pulled downwards gently? Explain your observation. [2]

35. The table below shows the pulse rate and breathing rate of Ali when he was at rest and when he was running.

Activities	Pulse Rate (heartbeats per min)	Breathing Rate (breaths per min)
resting	70	12
running	150	32

- a) Give a reason why Ali's breathing rate was higher when he was running quickly. [1]

- b) Based on the data above, explain why an increased pulse rate in Ali would result in more energy produced when he is running quickly. [1]

- c) Would Ali's pulse rate be higher or lower when he was walking as compared to when he was running quickly? Give a reason for your answer. [1]

SCORE	
-------	--

36. Meifen conducted an experiment with two similar potato plants. She removed the fruits and flowers on one of the plants.

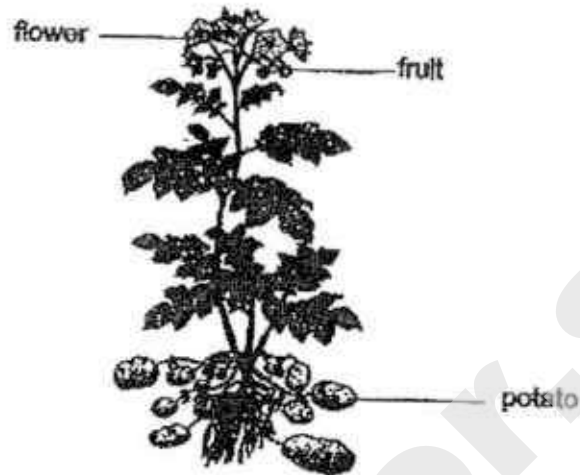

Meifen observed that potatoes on the plant with fruits and flowers removed were bigger compared to the other plant.

Explain why bigger potatoes were produced.

[2]

37. The diagram below shows a single-celled organism X.



- a) Organism X is able to make food. Name the part of the plant cell that enables organism X to do so. [1]

Organism X has a cap and a nucleus at its base. A scientist wanted to find out the function of the nucleus in organism X. He cut organism X into two halves as shown.

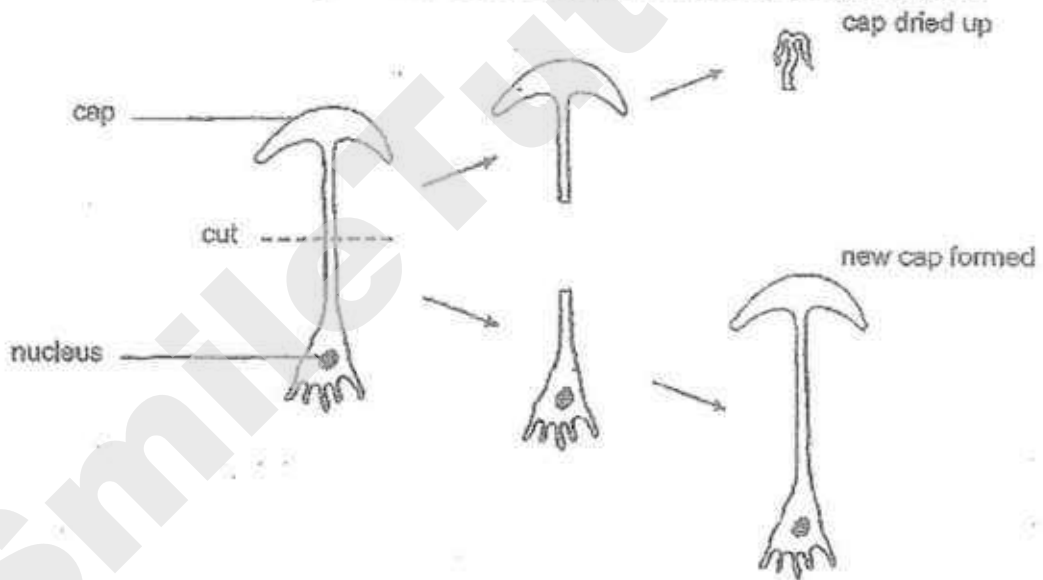

After a few days, the upper half of the organism with the cap dried up. The lower half continued to grow to form a new cap.

- b) Based on this observation, what can the scientist conclude about the function of the nucleus? [1]

- c) Besides replacing damaged and dead cells, give one other reason why our body needs to produce new cells. [1]

38. The diagrams below show two flowers from different plants, A and B.

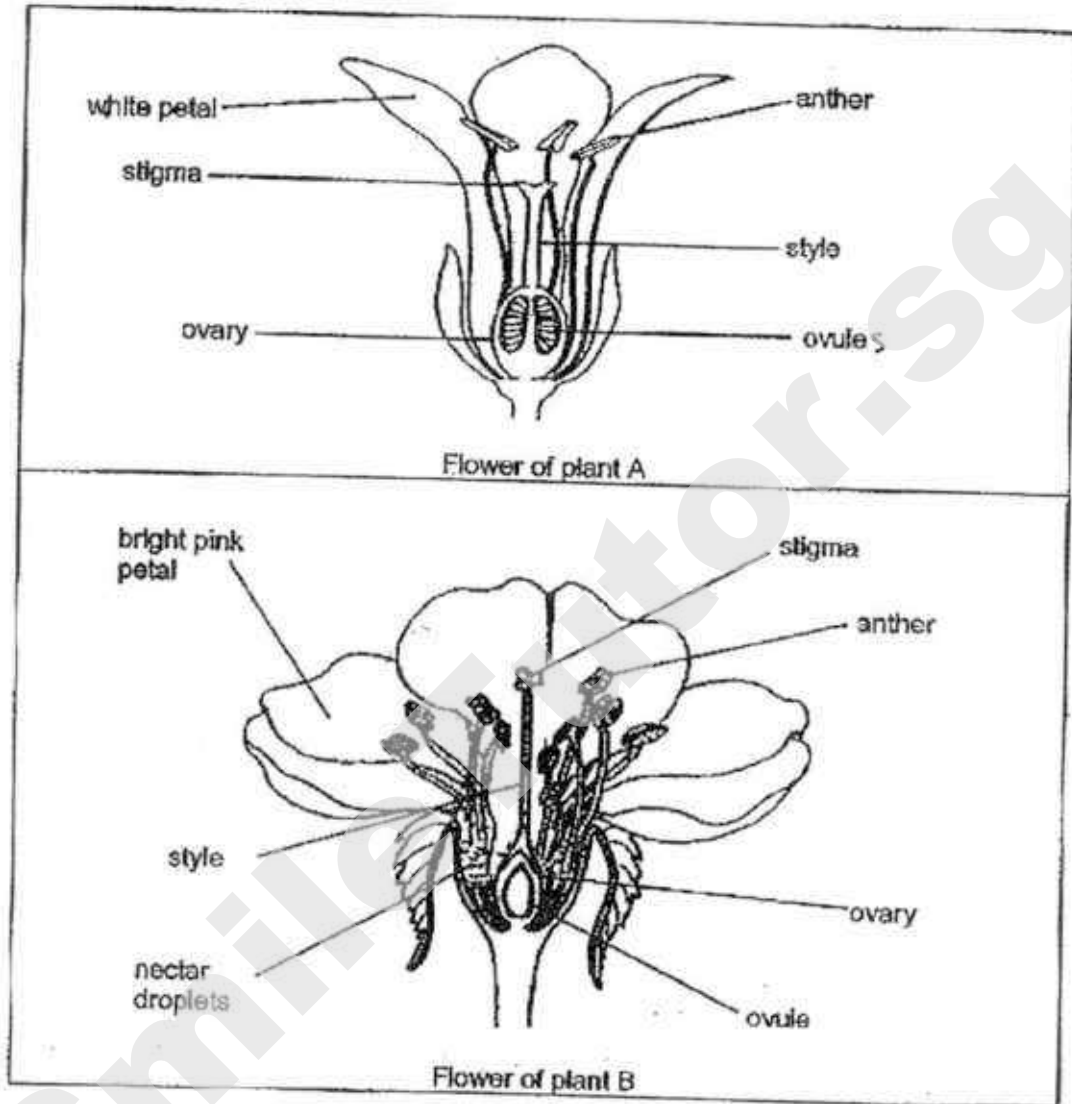

a) Which of the flowers is more likely to be pollinated by insects?
 Give two reasons for your answer.

[2]

The flower of plant _____ is more likely to be pollinated by insects.

Reason 1: _____

Reason 2: _____

SCORE	
-------	--

b) The diagram below shows a fruit.



Which plant, A or B, does this fruit belong to? Explain your answer.

[1]

c) The diagram below shows a bird on another plant, Y. The bird eats the fruits of plant Y and passes out the undigested seeds in its droppings.

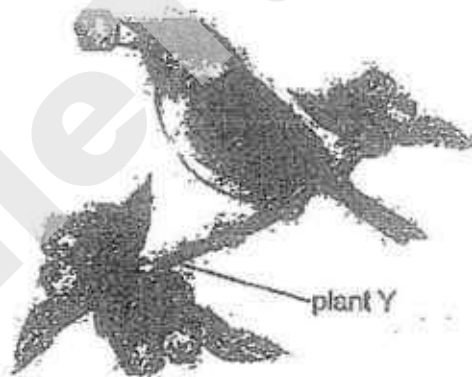

Other than dispersing the seeds far away from the parent plant, state another advantage of this method of seed dispersal for plant Y.

[1]

SCORE	
-------	--

39. Labeena tied her wet hair in a bun as shown in diagram 1 below. Her mother told her to let her hair down as shown in diagram 2.



- a) Her mother told her that her hair would dry faster if she lets it down. Why is this so? Explain your answer clearly. [1]

- b) Labeena noticed that her hair dried even faster when she sat under a spinning fan. Explain why this is so. [1]

40. Bala had a bimetallic strip, Y, made from two different metals. When heated, strip Y bent in the direction shown below. When the heated strip was cooled to room temperature, it straightened and returned to its original shape.

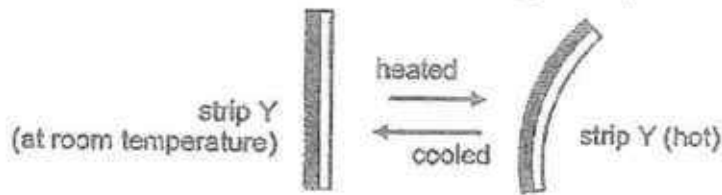

Bala used strip Y to make the lamp shown in Figure 1. Pin P is an iron pin attached to the lamp filament. It is in contact with strip Y and is fixed. He connected the lamp to a circuit as shown in Figure 2.

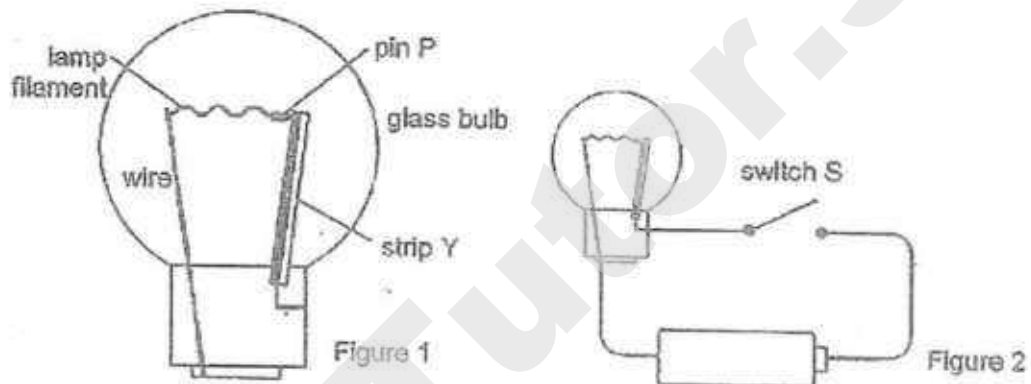

When Bala closed switch S, he observed that the lamp filament started to glow.

After a few seconds, strip Y became hot and the lamp turned off even though switch S was closed. The diagram below shows the lamp when it did not light up.

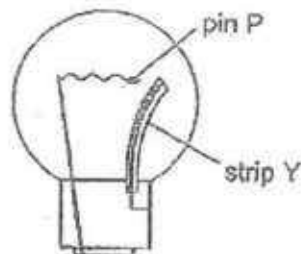

- a) Explain why the lamp did not light up when strip Y became hot. [1]

- b) A few seconds later, Bala observed that the lamp turned on again. Explain why the lamp lit up again. [2]

41. Brenda placed a beaker of sea water on top of a burner and prepared the set-up as shown below.

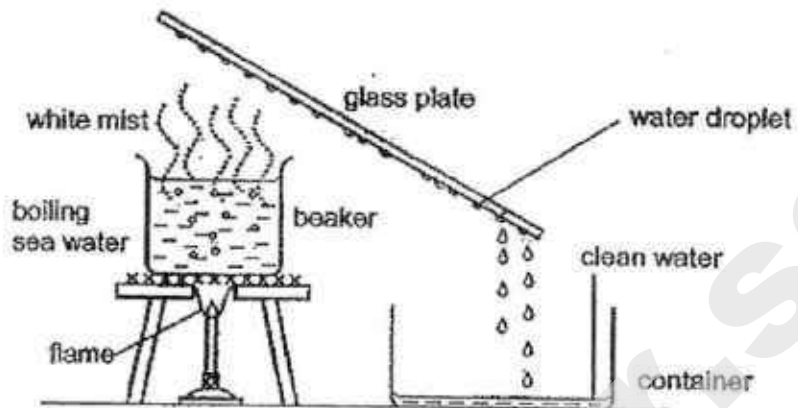

Brenda observed some white mist formed above the boiling water and water droplets formed on the glass plate.

- a) What is the state of matter of the white mist? [1]

- b) Explain how the water droplets on the underside of the glass plate were formed. [2]

- c) Brenda replaced the glass plate with a metal plate and repeated her experiment.

She observed that more clean water was collected in the container when she heated the same amount of sea water for the same duration.

Explain her observation.

[1]

End of Section B

Set by : Ms Parvin, Mrs Navin, Mrs Chiew
Vetted by: P5 Science teachers

SCORE	
-------	--

EXAM PAPER 2017 (P5)

SCHOOL: PEI CHUN

SUBJECT : SCIENCE

TERM : CA2

Q1	Q2	Q3	Q4	Q5	Q6	Q7	Q8	Q9	Q10
1	4	2	4	4	2	2	2	3	4
Q11	Q12	Q13	Q14	Q15	Q16	Q17	Q18	Q19	Q20
1	3	2	4	4	4	4	4	4	3
Q21	Q22	Q23	Q24	Q25	Q26	Q27	Q28		
3	1	3	2	2	3	4	1		

Name: _____ () Class: _____

P5 Science Continual Assessment Examination Answer Template – 2017

No.	Acceptable Answers
29 (a)	<p>Concept: Process of fertilization</p> <p><u> B , D , A , C </u></p>
(b)	<p>Concept: Female reproductive organs: ovary, womb and vagina. The ovaries produce eggs which are the female reproductive cells.</p> <p>The sperm _____ could not meet reach _____ the egg.</p>
30 (a)	<p>Concept: Magnetic force increases when the magnets are closer to the magnetic objects.</p> <p>Requirement of the question: <u>Relationship</u> between the magnetic attraction of a magnet and the distance from the pins.</p> <p>As the distance between the magnet and the pins <u>increases</u>, the attraction of the magnet <u>decreases</u>.</p>
(b)	<p>Concept: Pole of a ring magnet has the same magnetic strength</p> <p><u> Muthu </u>. Positions A, B and C are <u>all</u> on the <u> pole </u> ^{magnet} of the ring where the magnetic strength is the <u> same </u>.</p>
(c)	<p>Concept: Like poles of magnets repel.</p> <p>Magnet <u> Q </u> repels magnet <u> P </u> as the <u> like </u> poles of both magnets are <u> facing </u> each other.</p> <p>Common mistake: Q and P are like poles. (Wrong). Explanation: A magnet cannot have only one pole. A magnet must have a North and a South pole.</p>
(d)	<p>Concept: Magnetic forces increases when the magnets are close to each other.</p> <p>The <u> magnetic </u> force of repulsion <u>increased</u> as the magnets moved closer to each other / decreased.</p>
(e)	<p>Concept: Like poles of magnets repel.</p> <p>Magnet <u> S </u> repelled magnet <u> Q </u>, <u> pushing </u> magnet Q closer to magnet <u> P </u>.</p>
31 (a)	<p>Concept: Graph reading skills</p> <p>Requirement of the question: For both lines, P & R, if they are lengthened, both lines meet at the point 0mm or 0g.</p> <p><u> 0 </u> cm / mm</p>
(b)	<p>Concept: Test for flexibility of material</p>

	Rod P <u>broke</u> .
(c)	<p>Concept: An inflexible object does not bend easily. Requirement of the question: Comparison between the properties of rod Q and R must be made using the data in the graph.</p> <p>Rod <u>Q</u>. It bent <u>less</u> than rod <u>R</u>.</p>
32 (a)	<p>Concept: Light is blocked by an opaque material.</p> <p>First point: Light is <u>blocked</u> by the ball. / Light cannot pass through the ball.</p> <p>Second point: <u>—</u> / <u>No</u> light will be detected by the light sensor</p>
(b)	<p>Concept: When the ball is going through the hole, the light sensor cannot detect the light. Look at the graph and count the number of intervals that shows a 0 amount of light detected by the sensor.</p> <p><u>4</u></p>
(c)	<p>Concept: Graph reading skills based on data provided.</p> <p><u>No</u>. The ball took <u>different amount of time</u> to go through the hole. / The ball blocked the light for different amount of time.</p>
33 (a)	<p>Concept: A poor conductor of heat gains and loses heat slower. Requirement of the question: Pupils needs to state that X and Y might be the poorest conductor of heat and explain why. The more water we have in the beaker, the more time it'll take for the water in the beaker to boil.</p> <p><u>No</u>. The amount of water in each of the beakers and the time taken for the water in each beaker to start boiling were <u>defferent</u>. Thus, <u>X</u> and <u>Y</u> could be the <u>poorest</u> conductor of <u>heat</u>.</p> <p>OR</p> <p>Yes. If the same amount of water was poured into the beakers placed on X and Y, the water in the beaker placed above X would take a longer time to boil. Thus, material X is the poorest conductor of heat.</p>
(b)	<p>Concept: Fair Test Requirement of the question: The material must be mentioned for one of the suggestions.</p> <p>He should use the <u>same material</u> for both metal plates. He should use <u>water of the same temperature</u> in both beakers.</p>
34 (a)	Concept: Identify gases entering and exiting the blood stream in a lung.

	<p>S: <u>oxygen</u></p> <p>T: <u>carbon dioxide</u></p>
(b)	<p><i>Concept: Functions of tiny air sacs found in the air tubes.</i> <i>Requirement of the question: Pupils must state the origin of the exposed surface area.</i></p> <p>It increases the surface area in contact between the <u>air sea</u> and <u>the blood vessels</u>. Thus, the amount of gas S absorbed into the blood is increased.</p>
(c)	<p><i>Concept: Lung Machine</i> <i>Requirement of the question: Pupils must state</i></p> <ol style="list-style-type: none"> 1. Observation of the balloon from the diagram. 2. State the source of air. 3. Check if the air enter or leave the balloon. 4. Location where the air entered the balloon. <p>The balloons are <u>inflated</u> <u>Air</u> from the surrounding <u>entered</u> the balloons through the opening of the glass tubing.</p>
35 (a)	<p><i>Concept: When we exercise, our breathing rate increases so that we can take in more oxygen.</i> <i>Requirement of the question: Pupils will need to compare the breathing rate when Ali is resting.</i></p> <p>He needs to take in <u>more</u> oxygen to produce more energy when he was running quickly.</p>
(b)	<p><i>Concept: Increased pulse rate results in more digested food and oxygen being transported in the blood to various parts of the body.</i> <i>Requirement of the question: Pupils will need to compare the pulse rate when Ali is resting.</i></p> <p><u>More</u> digested food and oxygen are transported to <u>other part of the body</u>.</p>
(c)	<p><i>Concept: Our pulse rates are lower when we do less vigorous exercise and we need less energy, as compared to when we do vigorous exercise.</i> <i>Requirement of the question: Comparison must be made using Ali's pulse rate when he was walking compared to when he was running.</i></p> <p><u>lower</u>. The body would require <u>less</u> energy for the walk.</p>

36	<p><i>Concept: Food made by the leaves is transported from leaves to the other parts of the plant.</i> <i>Requirement of the question: Comparison must be made to when the fruits and flowers on one of the plants are not removed.</i></p> <p>Food made in the <u>leaves</u> will not be <u>transport</u> to the fruits and flowers, <u>more</u> food will then be <u>transported</u> to the potato instead. Thus, causing it to <u>increase</u> in size.</p>
37 (a)	<p><i>Concept: Function of parts of the cell</i> <u>chloroplast</u></p>
(b)	<p><i>Concept: Function of parts of the cell</i></p> <p>The nucleus is able to <u>repair</u> the damaged cell.</p>
(c)	<p><i>Concept: Purpose of producing new cells.</i></p> <p>To enable us to <u>grow</u>.</p>
38 (a)	<p><i>Concept: Factors that affect pollinators</i> <i>Requirement of the question: Pupils must compare the colours of the flowers in terms of brightness and also state the purpose of nectar droplets.</i></p> <p>The flower of plant <u>B</u> is more likely to be pollinated by insects.</p> <p>Reason 1: Its petals are <u>more</u> brightly-coloured / <u>more</u> attractively coloured / brighter.</p> <p>Reason 2: The flower of plant B has <u>nectar</u> droplets that will <u>attract the insect</u> to the flower.</p>
(b)	<p><i>Concept: Flower to fruit</i> <i>Requirement of the question: Pupils must state the similarity between the seeds in the fruit and the ovules in the flower of plant A.</i></p> <p><u>A</u>. This fruit has <u>many seeds</u> and the flower of plant A also has <u>many ovules arranged in a similar way as the seeds</u></p>
(c)	<p><i>Concept: Nutrients are needed for young plants to grow well.</i></p> <p>The bird's droppings will provide <u>nutrients</u> for the <u>seedlings</u>.</p> <p>* The seeds do not need nutrients from the droppings to germinate.</p>

39 (a)	<p><i>Concept: Rate of evaporation is affected by the exposed surface area of water</i> <i>Requirement of the question: Pupils need to compare the exposed surface area of the wet hair when the wet hair is tied up and when the wet hair is not tied.</i></p> <p>The _____ <i>exposed surface area of the wet hair</i> _____ is greater and the water will _____ <i>evaporate faster</i> _____ / the rate of evaporation will be higher.</p>
b)	<p><i>Concept: Rate of evaporation is affected by the presence of wind</i></p> <p>The _____ <i>wind</i> _____ from the spinning fan and ^{will blow} the water on her wet hair would _____ <i>to evaporate</i> _____.</p>
40 (a)	<p><i>Concept: Open & closed circuit based on bimetallic strip.</i> <i>Requirement of the question: Pupils must state their observation from the diagram.</i></p> <p>Strip _____ <i>Y</i> _____ <i>opened</i> bent away from pin P. Hence, the circuit was <u><i>straightened</i></u>.</p>
(b)	<p><i>Concept: Effects of materials which are good conductors of heat in an electrical circuit.</i></p> <p>Strip _____ <i>Y</i> _____ cooled down to room temperature and _____ <i>straightened</i> _____.</p> <p>It touched _____ <i>pin P</i> _____ and the circuit was _____ <i>closed</i> _____.</p>

41 (a)	<p>Concept: White mist is a cloud of water droplets formed in the air and the water droplets can be seen / observed. Water in gaseous state (steam or water vapour) cannot be seen.</p> <p><u>liquid</u> state</p>
(b)	<p>Concept: Formation of water droplets through evaporation and condensation. Requirement of the question: 1. Source of the steam / water vapour 2. Temperature difference 3. Surface of contact 4. Heat gain or loss 5. Process of condensation.</p> <p>Common mistake: The warm water vapour from the surrounding air condensed. (Wrong source) The boiling seawater evaporated into white mist. (When the seawater is boiling, it does not evaporate.) The white mist lost heat and condensed. (Water droplets are already in liquid state.)</p> <p>The sea water in the beaker <u>gained heat, boiled</u> and became <u>steam</u>. The <u>steam</u> touched the <u>cooler</u> surface of the glass plate, <u>lost</u> heat ($\frac{1}{2}$) and <u>condensed</u> into tiny water droplets.</p> <p>* Water boils at its boiling point of 100°C and becomes steam. Water evaporates at any temperature below the boiling point and becomes water vapour. When water changes from liquid state to gaseous state at the boiling point, we do NOT say that the water has evaporated.</p>
(c)	<p>Concept: Conductors of heat Requirement of the question: Pupils have to <u>compare</u> whether metal or glass is a better conductor of heat. Then pupils will have to explain their choice</p> <p>More water will be collected. As metal is a <u>better</u> conductor of heat, the steam to lose heat <u>faster</u> to the metal plate and more steam condensed on the metal plate.</p> <p>* The metal plate is of the same temperature as the glass plate. Both of them should be at room temperature at the start of the experiment. It would feel cooler as it is a better conductor of heat and it could conduct heat away from our skin more quickly. Being a better conductor of heat, it would gain heat more quickly from the steam and it'll be hotter than the glass plate after a while. However, the heat gained will also be lost quickly to the surrounding air, so more steam could condense on it.</p>

RIVER VALLEY PRIMARY SCHOOL
CONTINUAL ASSESSMENT 2 / 2017
PRIMARY 5

STANDARD SCIENCE

(BOOKLET A)

Name : _____ ()

Date : 16 Aug 2017

Class : P5 _____

Total Time for Booklet A & Booklet B : 1 hour

INSTRUCTIONS TO CANDIDATES

1. Write your name, index number and class in the space above.
2. Do not turn over this page until you are told to do so.
3. Follow all instructions carefully.
4. Answer all questions.
5. For Section A, shade your answers for questions 1 to 10 in the Optical Answer Sheet (OAS) provided.
6. For Section B, write your answers for questions 11 to 18 in the space provided in the booklet.
7. The total marks for Booklet A is 20 marks.

Section A (20 marks)

For each question 1 to 10, four options are given. One of them is the correct answer. Make your choice (1, 2, 3 or 4). Shade the oval (1, 2, 3 or 4) on the Optical Answer Sheet.

1. The diagram below shows Circuit A, B, C and D with different arrangements of identical batteries and bulbs. All the bulbs lighted up.

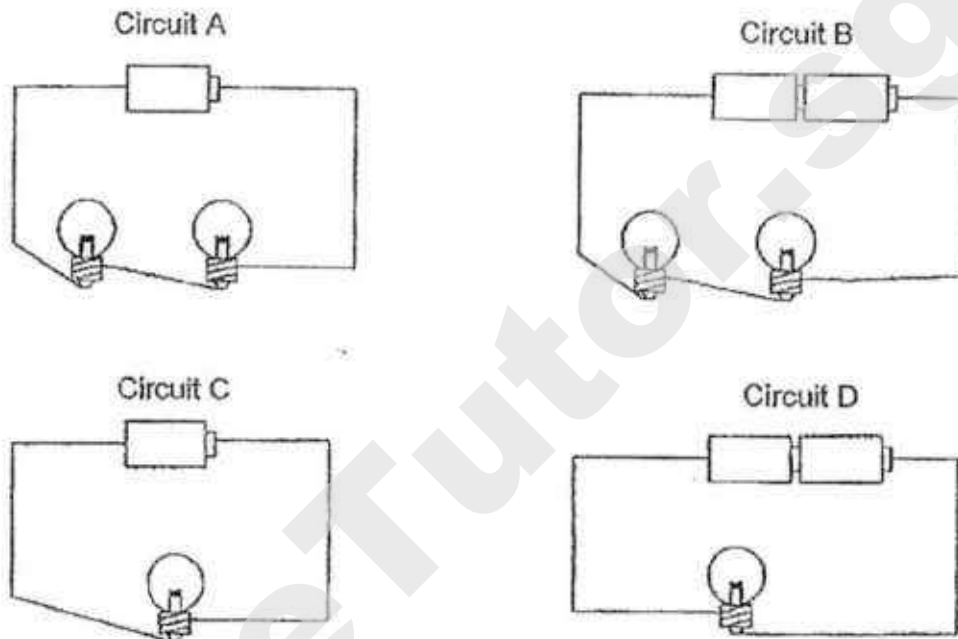

Which one of the following shows the degree of brightness of the bulbs in the circuits?

	Bright	Brighter	Brightest
(1)	A	B	C
(2)	C	D	B
(3)	A	C	D
(4)	B	C	A

()

2. Peter set up the circuit shown below.

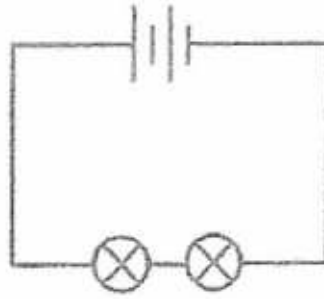

Which of the following would decrease the brightness of the bulbs?

- A: Arrange the bulbs in parallel
- B: Decrease the number of batteries used
- C: Add one more bulb in series with the other bulbs
- D: Add one more battery in series with the other batteries

- (1) A and B only
- (2) B and C only
- (3) C and D only
- (4) A, C and D only

()

3. Sarah tested the switches in an electrical circuit and obtained the results as shown below.

Switch Y	Switch Z	Number of bulbs lighted
Open	Open	0
Closed	Open	2
Open	Closed	2
Closed	Closed	2

Which one of the circuits below did Sarah use?

(1)

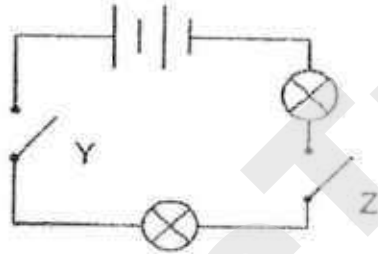

(2)

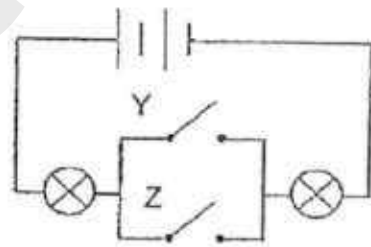

(3)

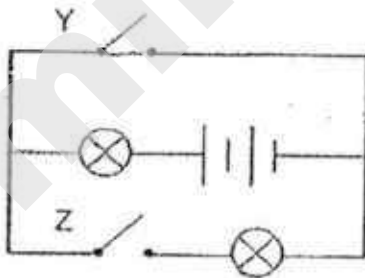

(4)

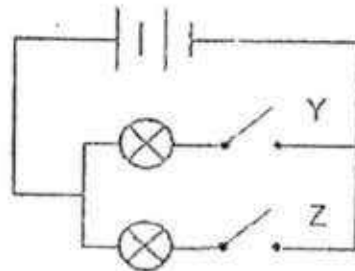

()

4. The circuit card shown below has a metal clip at points W, X, Y and Z. Some of the clips are connected by wires behind the card.

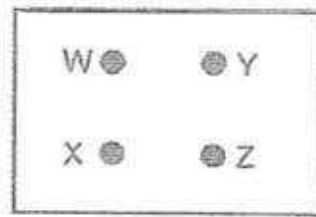

Circuit card

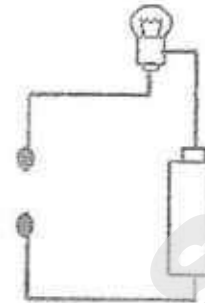

Circuit tester

A circuit tester above is used to test the circuit cards.

The results are recorded in the table below.

Circuit tester connected to clips at:	Does the bulb light up?
W and Z	Yes
W and X	Yes
Y and Z	No

Which one of the following circuit cards shows the correct connections of the wires?

(1)

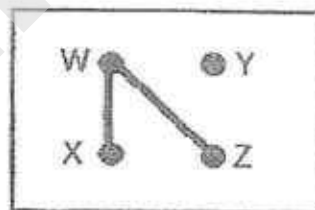

(2)

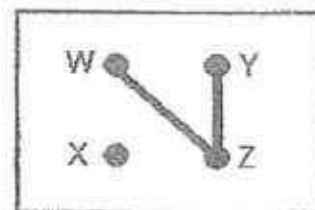

(3)

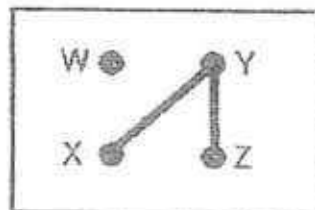

(4)

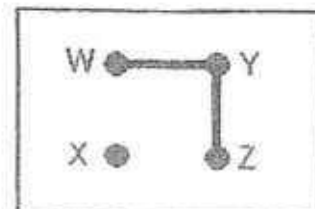

()

5. Alan used the circuit below to test on three objects, P, Q and R as shown in the diagram. The three objects were made from different materials.

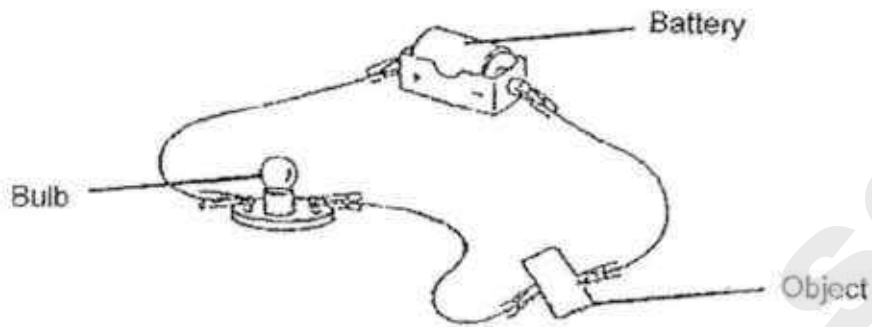

The results of the test were as follows:

Object	Did the bulb light up?
P	No
Q	Yes
R	Yes

Which one of the following shows the likely materials that the objects P, Q and R were made from?

	P	Q	R
(1)	Paper	Glass	Plastic
(2)	Aluminium	Steel	Rubber
(3)	Rubber	Copper	Aluminium
(4)	Gold	Iron	Steel

()

6. The diagram below represents the water cycle.

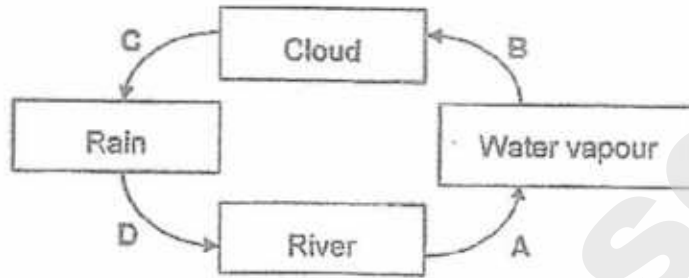

Which one of the following is correct?

	Condensation occurred at	Evaporation occurred at
(1)	A	B
(2)	B	C
(3)	D	C
(4)	B	A

()

7. Ahmad travelled to school by an air-conditioned bus. He observed that the windows looked different during different times of the day. He recorded his observations below.

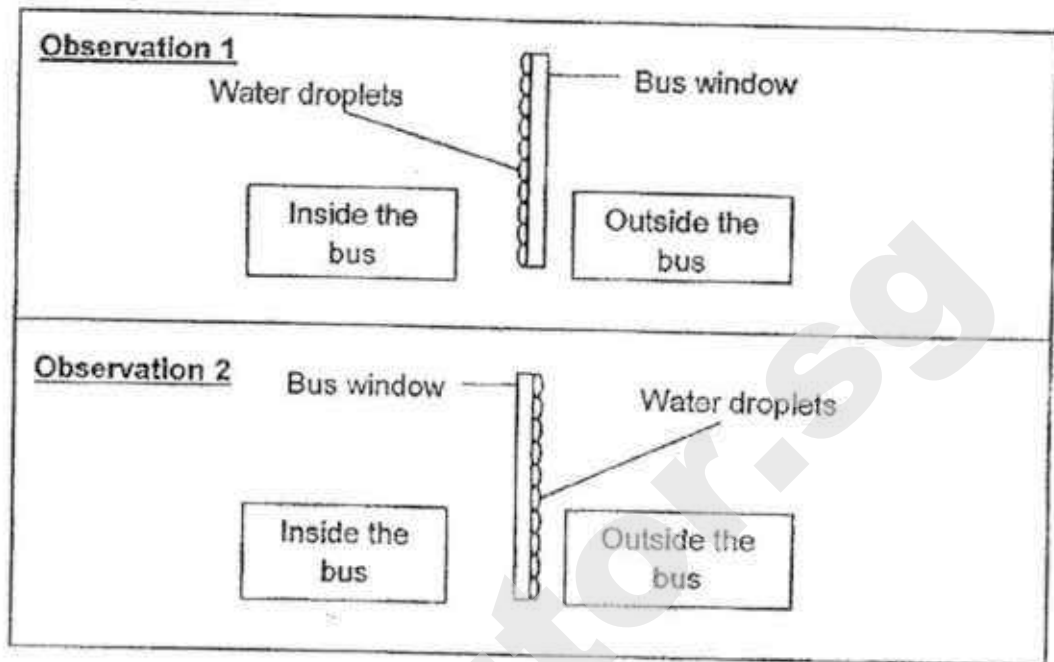

He then made four statements based on his observations.

- A. In Observation 1, the temperature outside the bus was the same as the temperature inside the bus.
- B. In Observation 1, water droplets are formed when the water vapour inside the bus condenses on the window.
- C. In Observation 2, the temperature outside the bus was higher than the temperature inside the bus.
- D. In Observation 2, water droplets are formed when the water vapour outside the bus condenses on the window.

Which of the following statements about Ahmad's observations are correct?

- (1) A and B
- (2) C and D
- (3) A, B and C
- (4) B, C and D

()

8. The diagram below shows the different states of water and the different processes it goes through.

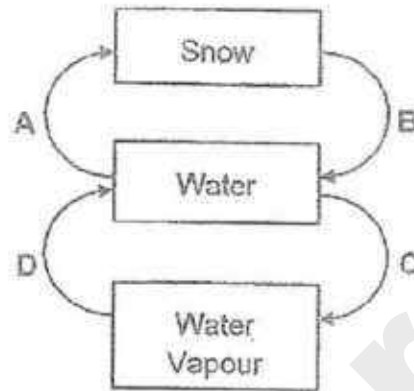

Which of the following correctly identifies the transfer of heat at A, B, C and D?

Process	Transfer of heat
A	heat loss
B	heat loss
C	heat loss
D	heat gain

- (1) A
(2) B
(3) C
(4) D

()

9. Caden's mum poured hot tea for him while they were having breakfast.



When the tea flowed into the cup, Caden noticed 'mist' along the trail of tea.

Which of the following statement(s) about the 'mist' is/are correct?

- A: The 'mist' is in the same state as rain.
- B: The 'mist' is in the same state as steam.
- C: The 'mist' condense to form water droplets.
- D: The 'mist' evaporate to form water vapour.

- (1) B only
- (2) A and D
- (3) B and C
- (4) C and D

()

10. The water cycle is a natural way of _____.

- (1) reducing flooding
- (2) reducing water wastage
- (3) making us use water wisely
- (4) making water reusable again

()

~End of Booklet A~

**CONTINUAL ASSESSMENT 2 /
2017 PRIMARY 5**

STANDARD SCIENCE

(BOOKLET B)

Name : _____ ()

Date : 16 Aug 2017

Class : P5 _____

Total Time for Booklet A & Booklet B : 1 hour

INSTRUCTIONS TO CANDIDATES

1. Write your name, index number and class in the space above.
2. Do not turn over this page until you are told to do so.
3. Follow all instructions carefully.
4. Answer all questions.
5. For Section A, shade your answers for questions 1 to 10 in the Optical Answer Sheet (OAS) provided.
6. For Section B, write your answers for questions 11 to 18 in the space provided in the booklet.
7. The total marks for Booklet B is 30 marks.

Booklet A		/20
Booklet B		/30
Total		/50
Parent's Signature		

Section B (30 marks)

Write your answers to questions 11 to 18 in this booklet.

11. Adam wears a pair of goggles when he goes swimming.

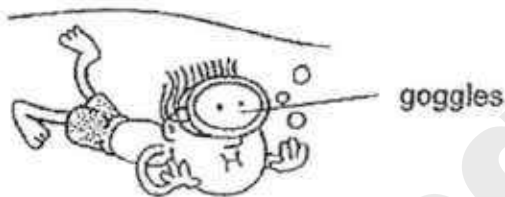

He notices that as he swims, tiny water droplets start to form on the insides of his goggle lens.

- (a) Explain how the tiny water droplets formed on the inside of his goggle lens. [1m]

Adam went for a swim at two different times; 12 noon and 7 pm. He noticed that the water droplets inside his goggle lens formed fastest at one of the times.

- (b) At which time did the water droplets form the fastest? Explain your answer. [2m]

- (c) When Adam came out of the pool, he felt cold. Explain why he felt cold. [1m]

	4
--	---

12. Bala placed three different containers, A, B and C, in an open field. Each container contains the same volume of water.

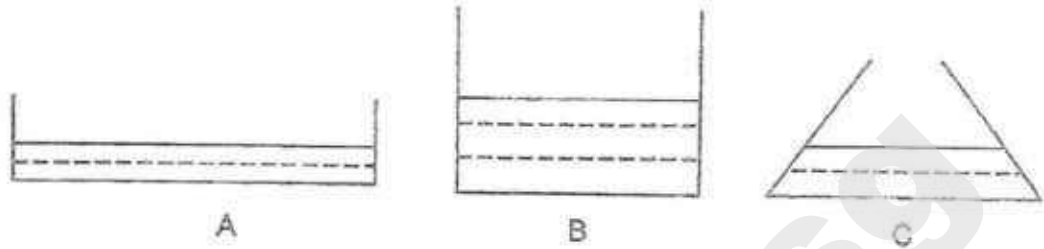

After some time, he measured the volume of water in each container and drew line graphs for each container.

- (a) The aim of Bala's experiment is to find out if the amount of _____
 _____ affects how much water evaporates. [1m]
- (b) Bala drew a line graph for container B shown below.
Draw and label the line graph for container A and container C below. [2m]

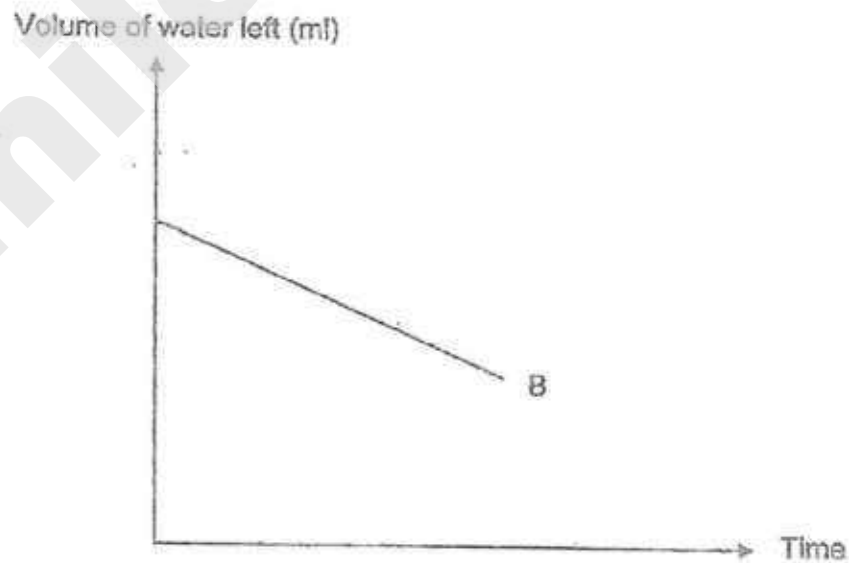

	3
--	---

13. Lucy placed a beaker of water over a heater and covered it with a metal plate as shown in the diagram below.

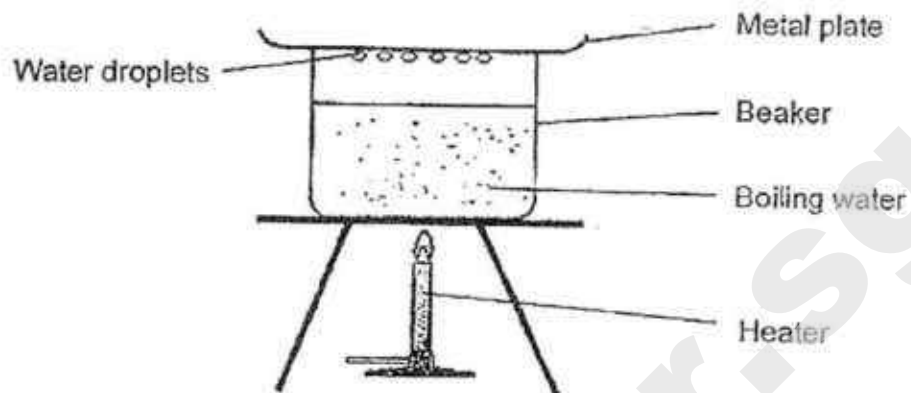

After some time, she noticed that water droplets had formed on the bottom of the metal plate and fallen back into the water.

- (a) What would she observe about the water droplets if she put ice cubes in the metal plate? [1m]

Lucy then replaced the metal plate with a wooden board. She observed that the amount of water droplets had decreased.

- (b) Explain her observation. [2m]

	3
--	---

14. Weili was given the following items by her Science teacher. She had to make use of all the items given to set up a circuit such that when one bulb fused, the other bulbs will not light up.

- 3 bulbs
- 2 batteries
- 1 switch
- some electric wires

(a) Draw a circuit diagram in the box provided below to show the possible electric circuit that Weili had set up. [2m]



(b) Weili noticed that the wires she used in the experiment is covered with an outer layer of plastic. Explain the function of the layer of plastic. [1m]

(c) Other than plastic, what other material can be used to cover the wires? [1m]

	4
--	---

15. The diagram below shows a tunnel and the circuit on a toy train set up by Mary. The bulb only lights up when the whole train entered the tunnel fully.

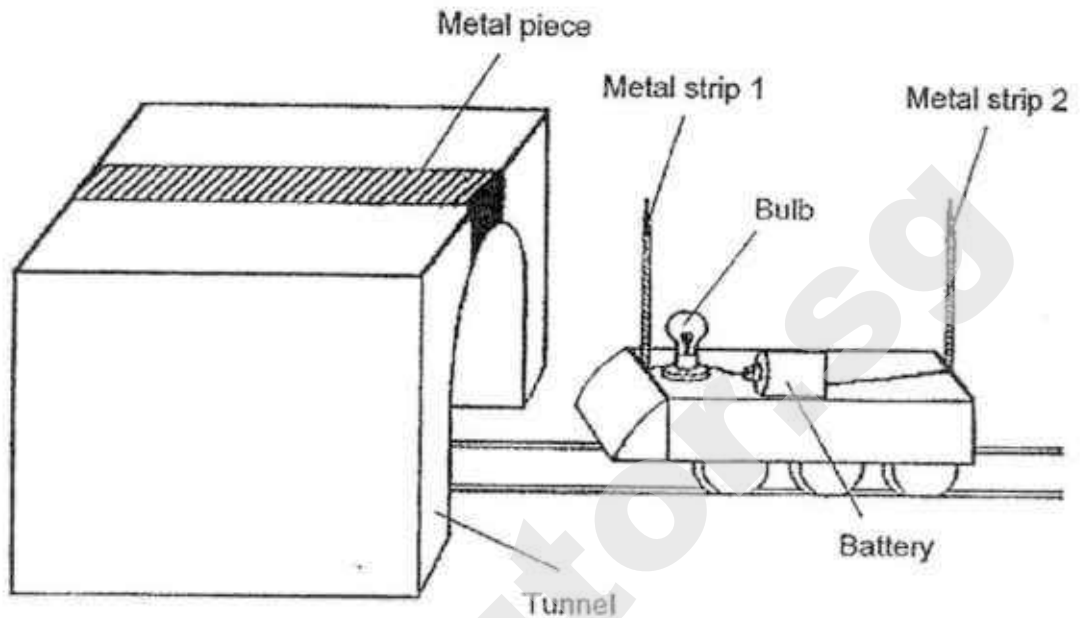

- (a) Explain why the bulb would not light up if only part of the train enters the tunnel. [2m]

Mary added three new batteries in series. The bulb lit up very brightly the first time the train entered the tunnel. However, when the train entered the tunnel again, the bulb did not light up.

- (b) Suggest two possible reasons why the bulb did not light up. [2m]

(i) _____

(ii) _____

	4
--	---

16. The diagrams below show the electrical circuit for light bulbs in Tom's house and Kevin's house.

Tom's house

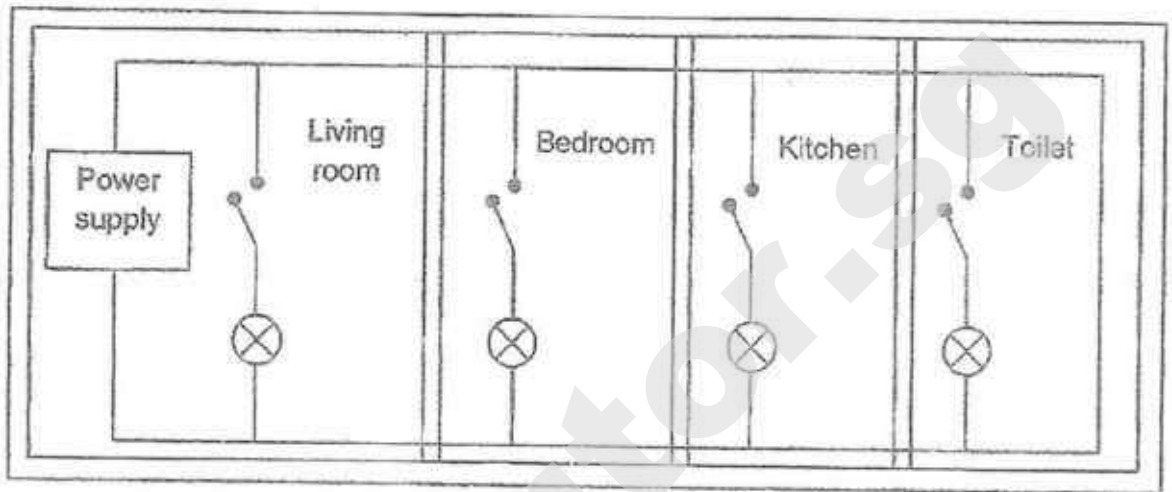

Kevin's house

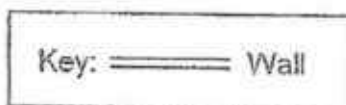
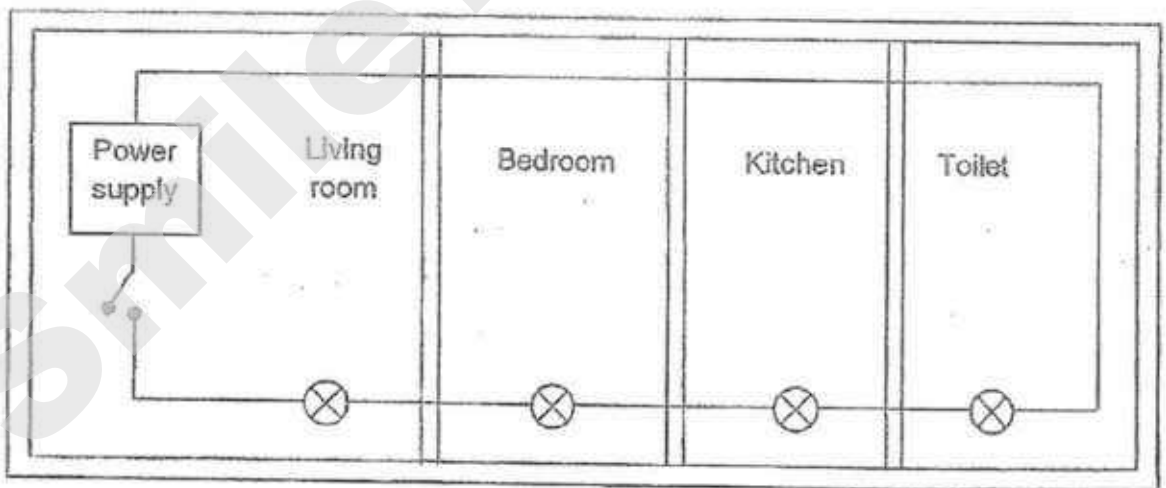

(a) Write one advantage of Kevin's electrical circuit compared to Tom's. [1m]

(b) Write one advantage of Tom's electrical circuit compared to Kevin's. [1m]

(c) If the power supply to Tom's and Kevin's houses are the same and both of them are using the same light bulbs, whose house would have brighter bulbs? [1m]

(d) Suggest two ways to conserve electricity. [1m]

(i)

(ii)

	4
--	---

17. Study the circuit below.

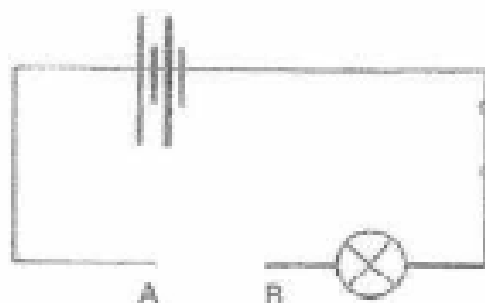

Ramu connected wires of different thickness to points A and B above. Each time the bulb lit up, the brightness was compared using a scale of 1 to 4, with 1 being the least bright and 4 being the brightest. The data collected is shown in the table below.

Thickness of wire	Brightness of bulb
1 mm	1
2 mm	2
3 mm	3
4 mm	4

- (a) What is the relationship between the thickness of the wire and the brightness of the bulb? [1m]

- (b) If Ramu replaced the wire at points AB with a pencil lead, what would he observe? [1m]

- (c) Explain your answer in (b). [2m]

	4
--	---

18. Karen set up the circuit below. She observed that one of the bulbs did not light up.

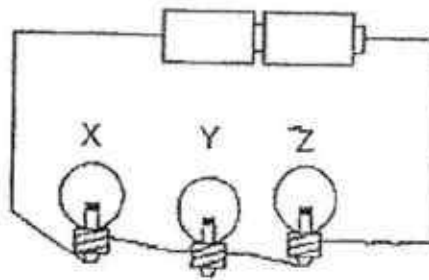

- (a) Which bulb did not light up? [1m]

Bulb _____

- (b) Give a reason why the bulb mentioned in (a) did not light up. [1m]

- (c) Complete the circuit below such that all three bulbs will light up. [2m]

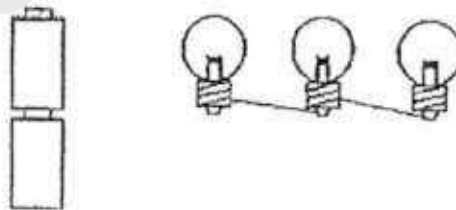

	4
--	---

~End of Paper~

SCHOOL : RIVER VALLEY PRIMARY SCHOOL
 LEVEL : PRIMARY 5
 SUBJECT : SCIENCE
 TERM : 2017 CA2

SECTION A

Q 1	Q2	Q3	Q4	Q5	Q6	Q7	Q8	Q9	Q10
3	2	2	1	3	4	4	1	3	4

SECTION B

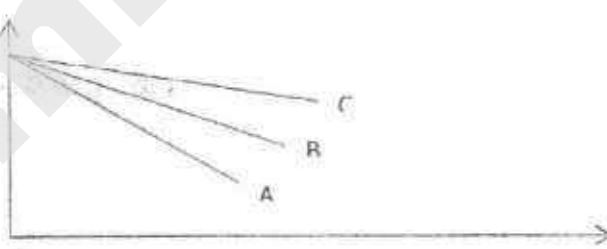
Q11)	<p>(a) The water in the swimming pool is cold. The cold surface of the goggles comes into contact with the warmer water vapour in the goggles and condenses into tiny water droplets.</p> <p>(b) 7pm. At night, the surrounding air is colder, causing the water to be affected. The much cooler surface of the goggles will come into contact with the warm water vapour in the goggles and condense into tiny water droplets faster.</p> <p>(c) The water on his body absorbed heat from his body to evaporate, making him feel cold.</p>
Q12)	<p>(a) exposed surface area</p> <p>(b)</p> 
Q13)	<p>(a) More water droplets will form on the bottom of the metal plate.</p> <p>(b) The wooden board was not as cold as the metal plate, causing the rate of evaporation to be slower on the wooden board than the metal plate.</p>

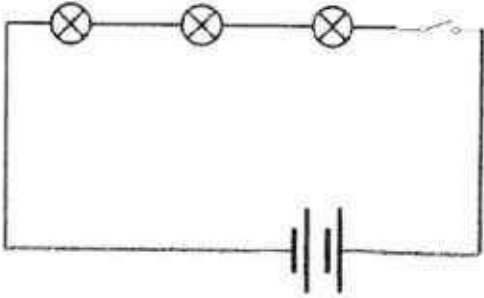
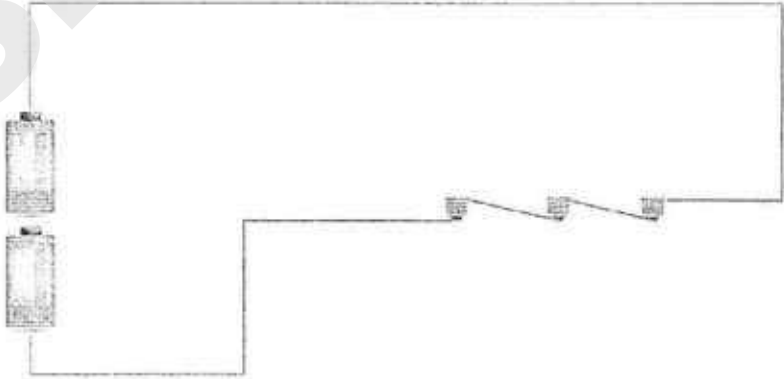
<p>Q14)</p>	 <p>(b) As plastic is a poor conductor of electricity, Weili will not be electrocuted.</p> <p>(c) Rubber</p>
<p>Q15)</p>	<p>(a) If only half of the train enters the tunnel, only metal strip 1 will touch the metal piece and will form an open circuit.</p> <p>(b) (i) The bulb had fused (ii) The batteries are flat</p>
<p>Q16)</p>	<p>(a) Kevin's electrical circuit uses less electricity compared to Tom's.</p> <p>(b) Tom's electrical circuit saves more electricity than Kevin's electrical circuit</p> <p>(c) Tom</p> <p>(d) (i) Switch off the lights when not in use (ii) Switch off any appliances which are not in use</p>
<p>Q17)</p>	<p>(a) The thicker the wire, the brighter the bulb.</p> <p>(b) The bulb will still light up</p> <p>(c) Pencil lead is a good conductor of electricity.</p>
<p>Q18)</p>	<p>(a) Bulb Y</p> <p>(b) The wires were only connected to the metal casing and not the metal tip for bulb Y.</p> <p>(c)</p> 

SEMESTRAL ASSESSMENT 1 (2017)

PRIMARY 5

SCIENCE

BOOKLET A

Wednesday

17 May 2017

1 hr 30 min

Name: _____ () Class: 5.(

INSTRUCTIONS TO PUPILS

- 1 Do not turn over the pages until you are told to do so.
- 2 Follow all instructions carefully.
- 3 There are 25 questions in this booklet.
- 4 Answer ALL questions.
- 5 Shade your answers in the Optical Answer Sheet (OAS) provided.

This question paper consists of 20 printed pages (inclusive of cover page).

Booklet A (50 marks)

For each question from 1 to 25, four options are given. One of them is the correct answer. Choose the correct option (1, 2, 3 or 4) and shade the correct oval on the Optical Answer Sheet (OAS). (25 x 2 marks)

1 Study the classification chart below.

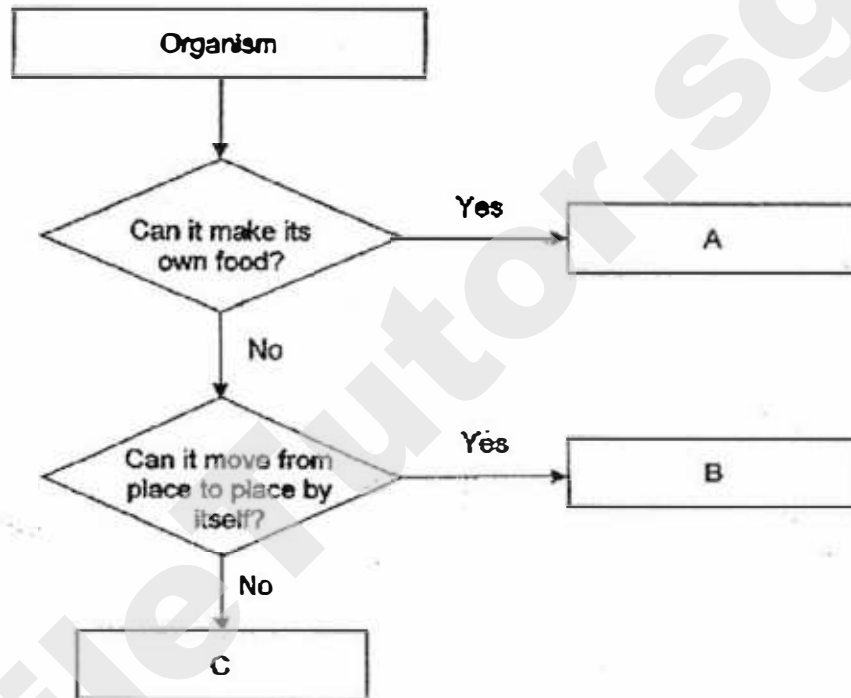

Which of the following can A, B and C be?

	A	B	C
(1)	Fern	Mould	Earthworm
(2)	Mould	Fern	Fungi
(3)	Mould	Fungi	Fern
(4)	Fern	Earthworm	Mould

- 2 Three pupils were arguing among themselves while making comparisons of the following organisms.



Organism A



Organism B



Organism C

Each pupil then made the following statements.

Susan: All the above organisms need food to grow.

John: Organisms A and B can move on its own but not organism C.

Dawn: Organisms B and C contain chlorophyll but Organism A does not.

Which of the above pupil(s) had made the correct statement(s)?

- (1) John only
 - (2) Dawn only
 - (3) Susan only
 - (4) John, Susan and Dawn
- 3 Weights are added to 2 rubber bands, A and B. The length of each rubber band, as weights are added to them is shown on the graph below.

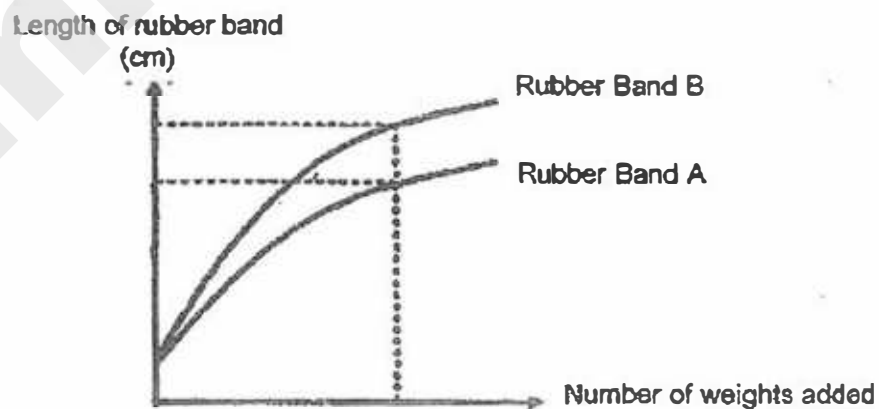

Based on the graph, what can be concluded about the rubber bands A and B?

- (1) Both rubber bands stretch to the same length when the same number of weights is added to each of them.
- (2) B requires more weights to be added before it stretches to the same length as A.
- (3) A requires more weights to be added before it stretches to the same length as B.
- (4) When the same number of weights is added to the rubber bands, A would stretch longer than B.

- 4 The diagram below shows the growth of a bean plant.

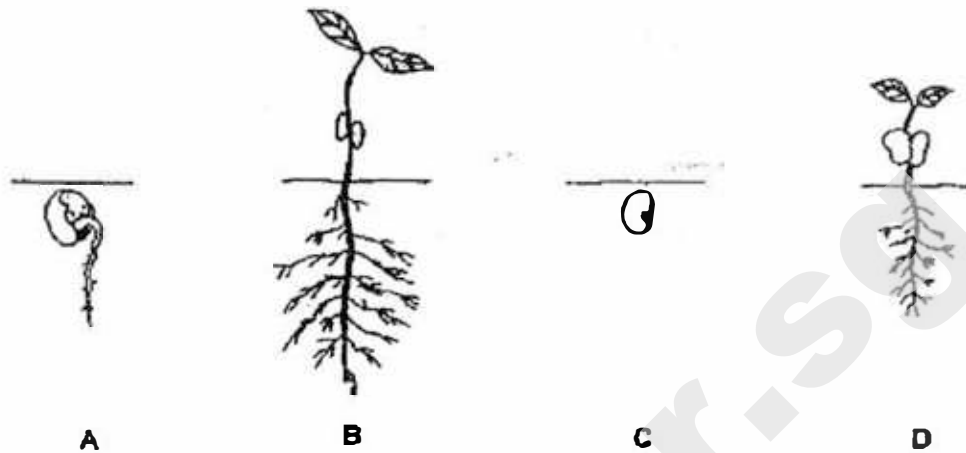

At which point of its growth does the bean plant need sunlight?

- (1) C only
 - (2) A and C only
 - (3) B and D only
 - (4) A, B, C and D
- 5 Study the experiment below.



What will happen to the water level at X and Y and the volume of water when the stone is gently dropped into the container?

	Water Level at X	Water Level at Y	Volume of Water
(1)	Increases	Increases	Remains the same
(2)	Decreases	Remains the same	Remains the same
(3)	Increases	Remains the same	Increases
(4)	Decreases	Increases	Increases

- 6 The graph below shows the number of days in each stage of the life cycle of an insect.

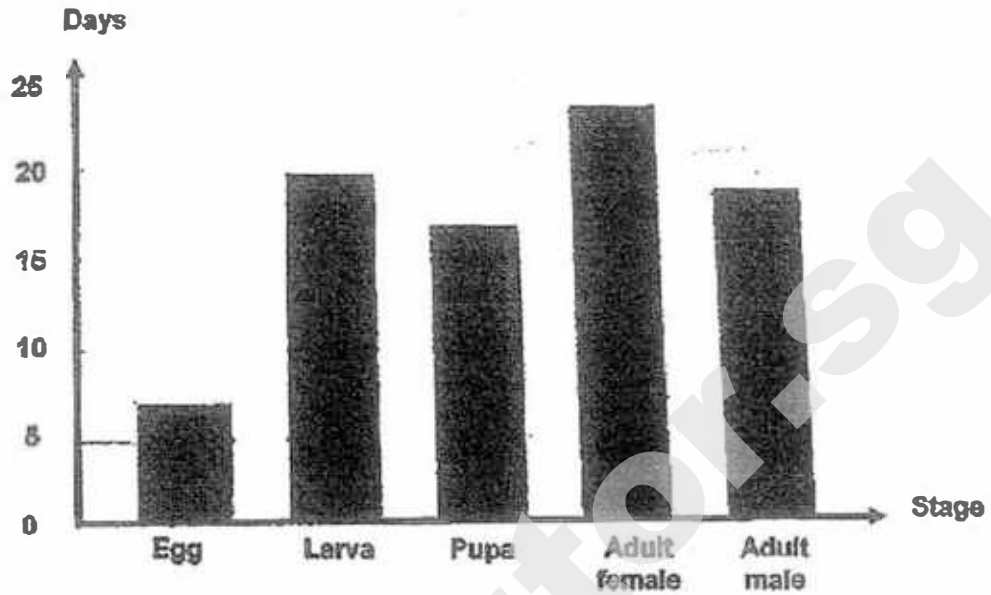

Based on the graph above, which of the following statement(s) is/are true?

- A The insect is a pupa for 20 days.
- B The insect has four stages in its life cycle.
- C There are more male adults than female adults.
- D It takes a shorter time for larva to become a pupa than an egg to become a larva.

- (1) B only
- (2) A and D only
- (3) B and C only
- (4) A, C and D only

- 7 An experiment was conducted with magnets of different sizes as shown in the diagram below.

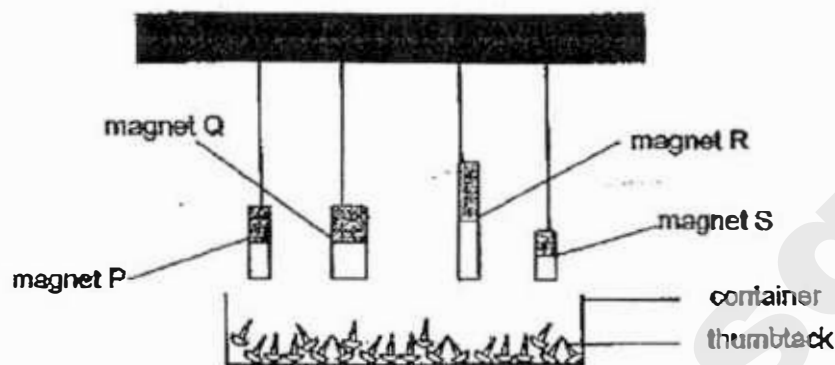

The results of the experiment are recorded in the table below.

Magnet	Number of thumbtacks attracted		
	1 st Attempt	2 nd Attempt	Average
P	4	3	3.5
Q	3	3	3
R	2	1	1.5
S	5	4	4.5

Based on the experiment, what conclusion can be drawn?

- (1) The thumbtacks attracted all the magnets.
 - (2) The poles of all the magnets are equally strong.
 - (3) Magnet S is weaker in magnetism than magnet R.
 - (4) The size of a magnet does not affect its magnetic strength.
- 8 Joan brought a bar magnet close to a small dish of iron nails as shown in the diagram below.

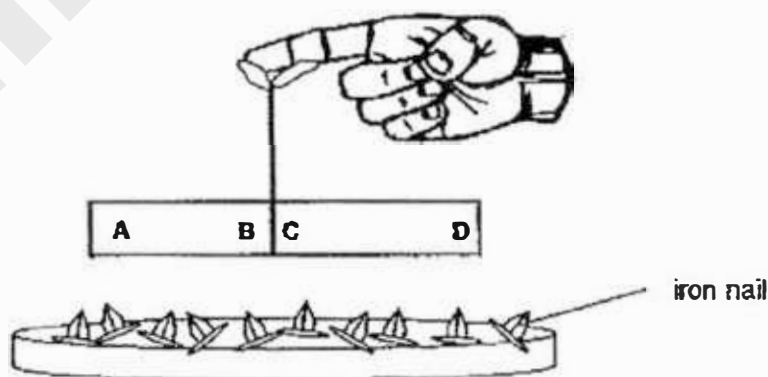

She observed that the magnet attracted the iron nails. Which parts of the magnet would attract the least number of iron nails?

- (1) A and D only
- (2) B and C only
- (3) A, C and D only
- (4) B, C and D only

- 9 The diagram below shows the arrangement of four bar magnets.

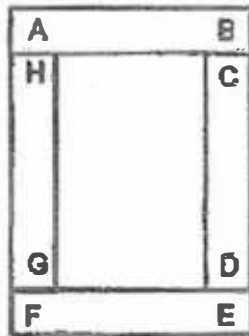

Which of the following arrangements below is possible?

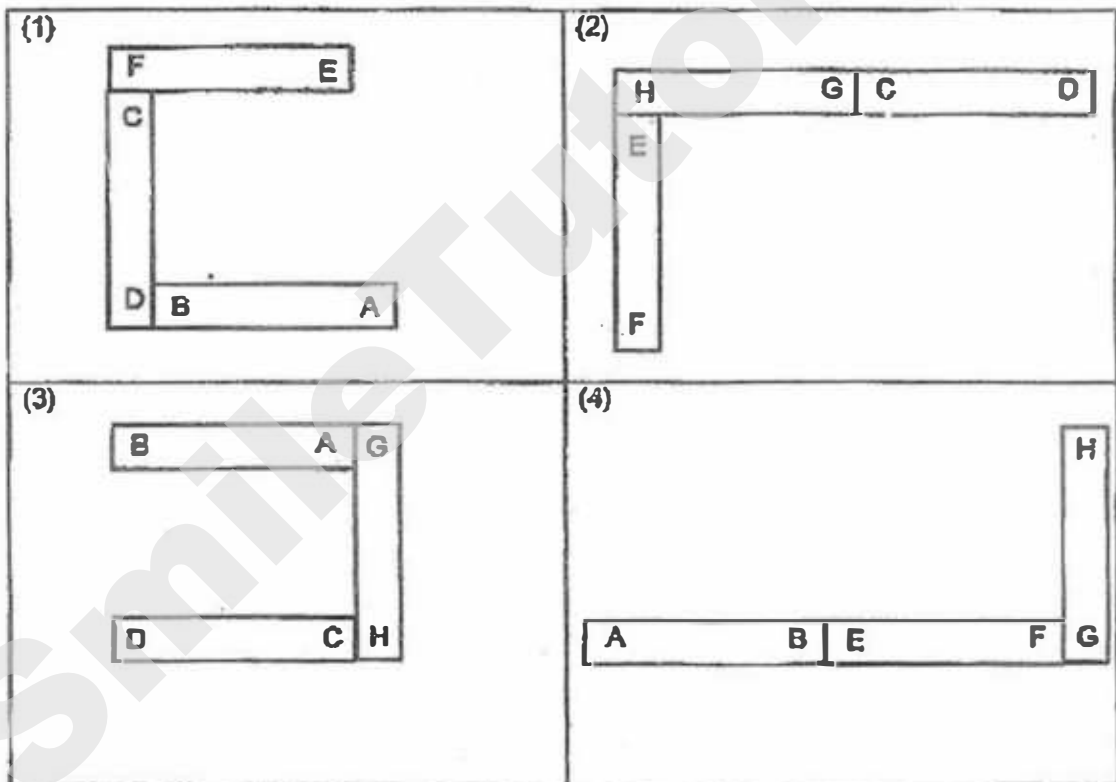

- 10 Jean carried out an experiment to test the magnetic strength of an iron bar when given a certain number of strokes. She used the North-seeking pole of the magnet to stroke the iron bar in the same direction. She recorded the number of paper clips the iron bar could attract and plotted a graph.

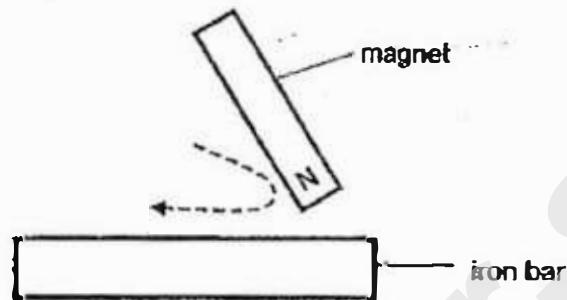

Which one of the graphs best represents the relationship between the number of strokes made and the number of paper clips the iron bar could attract?

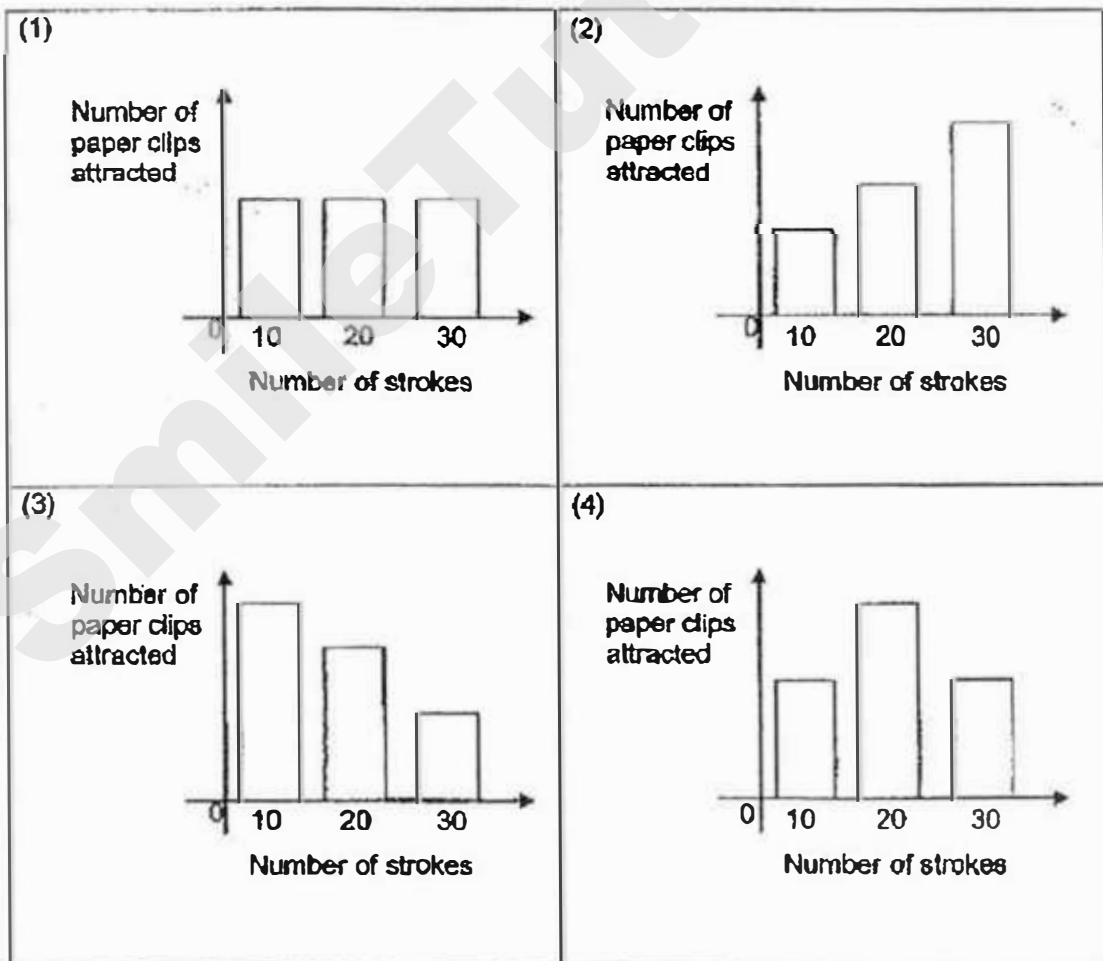

- 11 Study the diagram below. The magnet is glued to the lever and the lever is tilted downwards at the magnet.

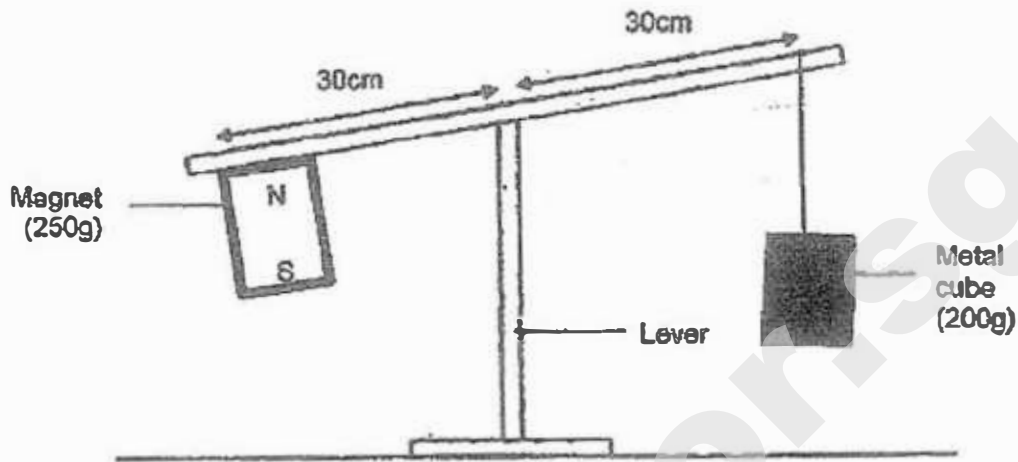

The diagram below shows what happens to the lever when Object X is added to the set-up.

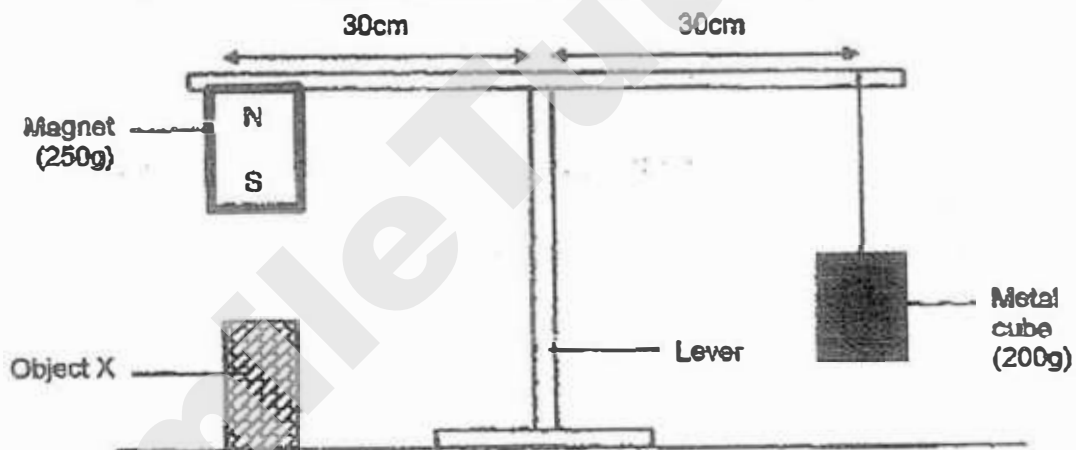

Based on the set-up above, which of the following conclusions about Object X is definitely true?

- (1) it is a magnet.
- (2) It is made of aluminum.
- (3) It is made of a non-magnetic material.
- (4) Object X is attracting the magnet on the lever.

- 12 The diagram below shows the human digestive system of a man. In which of the following parts are digestive juices produced?

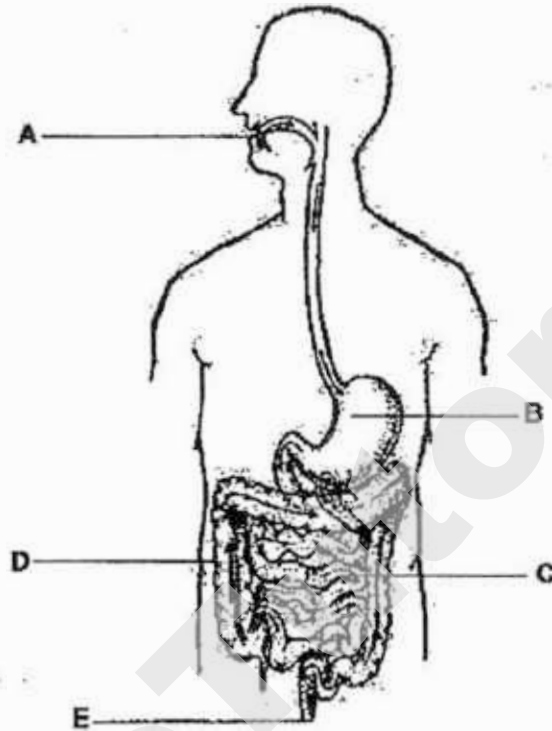

- (1) B and C only
(2) A, B and C only
(3) A, D and E only
(4) A, B, C and D only

13 The diagram below shows a plant.

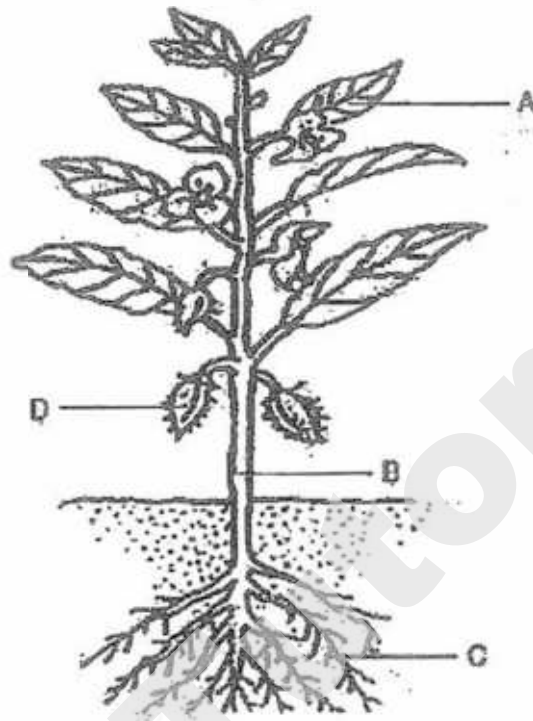

Which of the following identify the parts of the plant to the correct function?

	Makes food for the plant	Anchors the plant firmly to the ground	Holds the plant upright
(1)	D	B	C
(2)	A	B	C
(3)	D	C	B
(4)	A	C	B

- 14 The diagram below shows stomata on the surface of a leaf.

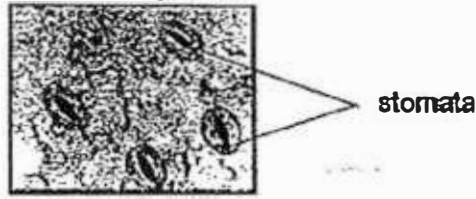

Which of the statements are true about stomata?

- A It traps light for photosynthesis.
- B It can be found on the underside of the leaves.
- C It allows only carbon dioxide to enter the leaves.
- D It allows gaseous exchange to take place with the surroundings.

- (1) A and C only
- (2) B and D only
- (3) A, C and D only
- (4) B, C and D only

- 15 Benjamin was asked to study the diagram of a cell as shown below. He then identified and described the function of four cell parts, A, B, C and D.

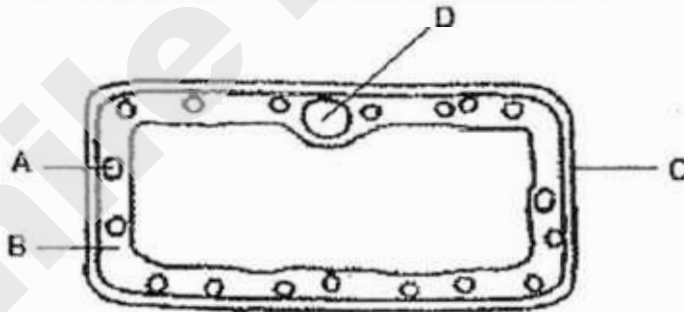

Which of his statement(s) identifies and describes the function of the cell part correctly?

- A C is the cell wall that gives the cell a regular shape.
- B D is a bigger chloroplast that controls all activities in the cell.
- C A is the chloroplast that contains chlorophyll for photosynthesis.
- D B is the cytoplasm that allows only certain materials to move in and out of the cell.

- (1) A only
- (2) A and C only
- (3) B, C and D only
- (4) A, B, C and D

- 16 Jerome places the stem of a plant in a container of water with red food colouring. After two hours, he cuts a section of the stem.

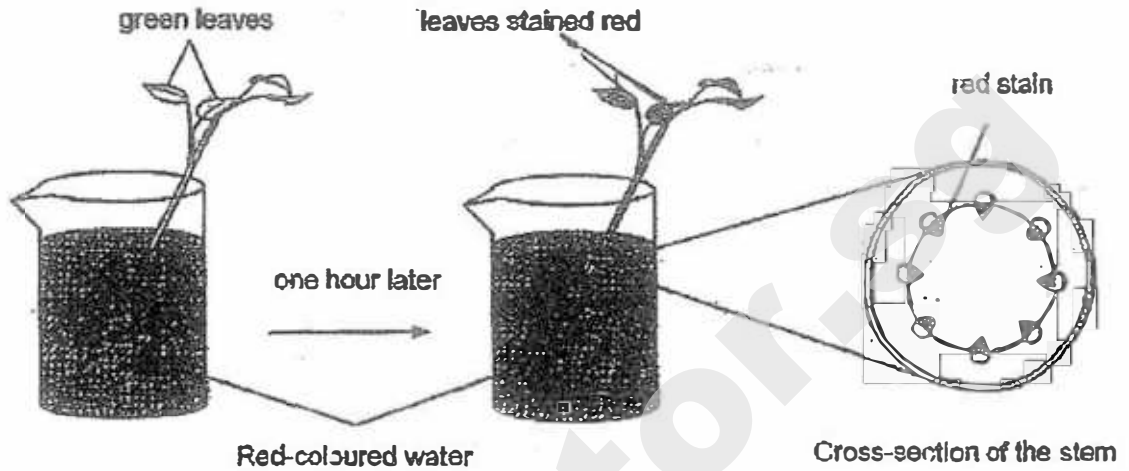

Observe the leaves and the stains on the cross-section of the stem. What can you infer from your observation?

- A The leaves need the red food colouring.
- B The parts of the stem coloured red transport water.
- C The red stains on the leaves are food made by the leaves.
- D The parts of the stem coloured red are connected to the leaves.

- (1) A and B only
- (2) B and D only
- (3) C and D only
- (4) A, B, C and D

- 17 The diagram below represents the human circulatory system. A, B, C and D represent the blood flowing in four different blood vessels in the systems. The arrows represent the direction of blood flow.

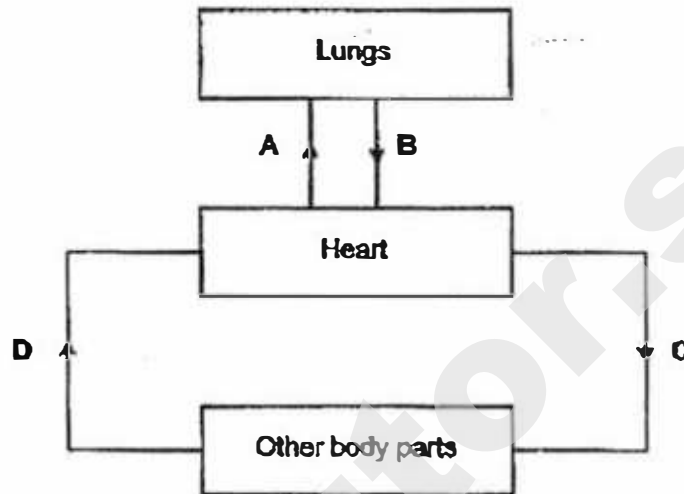

Which one of the following statements is Incorrect?

- A Blood at A is richer in oxygen than Blood at D.
- B Blood at D is richer in carbon dioxide than blood at B.
- C The heart pumps blood to only other parts of the body.
- D Gaseous exchange takes place in both the heart and lungs.

- (1) B only
- (2) B and C only
- (3) A, C and D only
- (4) A, B, C and D

18 The diagrams below show ⁵ circuits, A, B, C, D and E.

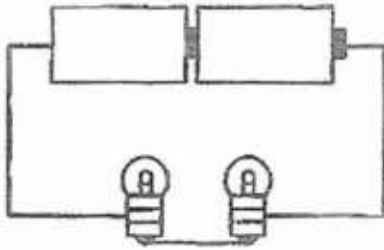

Circuit A

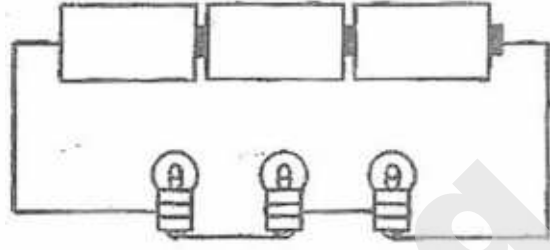

Circuit B

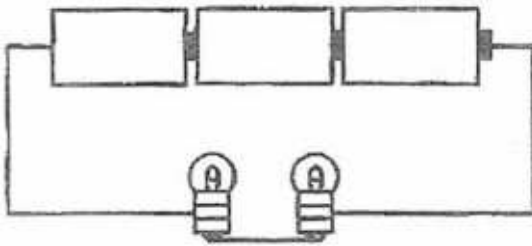

Circuit C

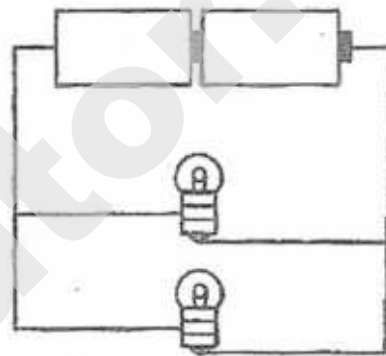

Circuit D

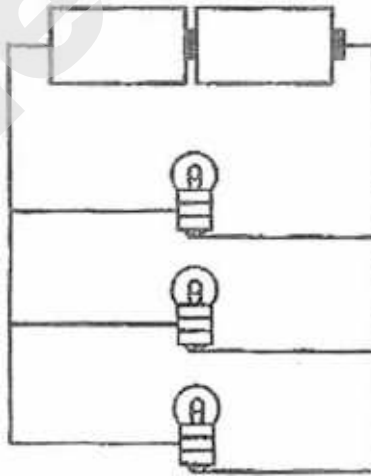

Circuit E

Which of the two circuits can be used to test the effect of the arrangement of bulb(s) on the brightness of the bulb(s)?

- (1) A and E
- (2) A and D
- (3) B and E
- (4) C and D

- 19 Dominic tested the properties of three rods, X, Y and Z using a circuit tester. A tick (✓) indicates that the bulb has lighted up or attracted paper clips. He recorded his results in the table below.

Rods	Bulb lights up	Attracted paper clips
X	✓	✓
Y	x	x
Z	✓	x

Then he used the flow chart as shown below to classify the rods.

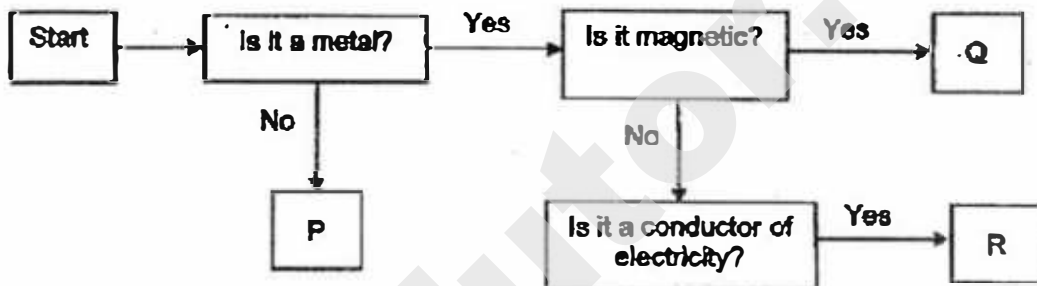

Which of the following letters can be used to represent rods X, Y and Z?

	Rod X	Rod Y	Rod Z
(1)	Q	R	P
(2)	P	Q	R
(3)	R	P	Q
(4)	Q	P	R

- 20 Daniel sets up the circuit as shown in the diagram below. The bulb does not light up.

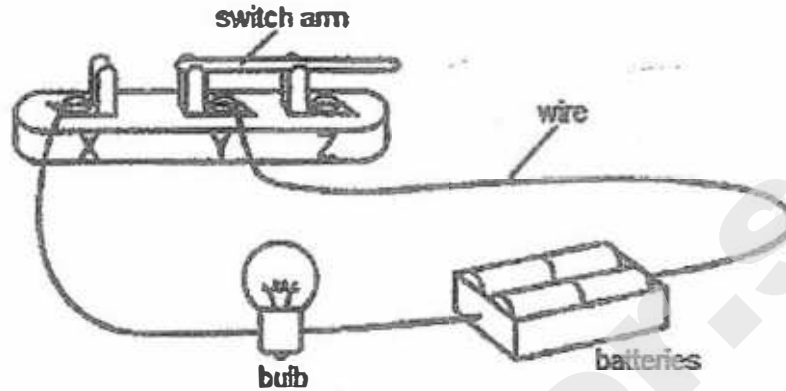

What should he do to make the bulb light up?

- A He should connect the wire to Z instead of Y.
 B He should flip the switch arm to X instead of Z.
 C He should connect the wires to the metal tip and metal casing of the bulb.
- (1) A only
 (2) A and C only
 (3) B and C only
 (4) A, B and C
- 21 Four bulbs, P, Q, R and S, are connected to two batteries as shown below.

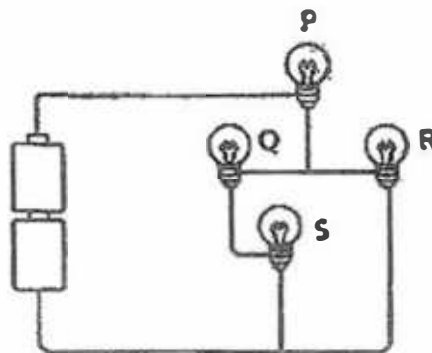

If bulb Q fuses, which bulb/bulbs will still remain lighted up?

- (1) P only
 (2) R and S only
 (3) P and R only
 (4) P, R and S

- 22 Evan conducted an experiment using a light sensor and a datalogger. Evan shone the torch on Material X and recorded the amount of light that can pass through. He then shone the torch on Material Y and recorded the amount of light that can pass through.

Material	Amount of light passing through (unit)
X	3000
Y	0

He arranged Materials X and Y in the order as shown below.

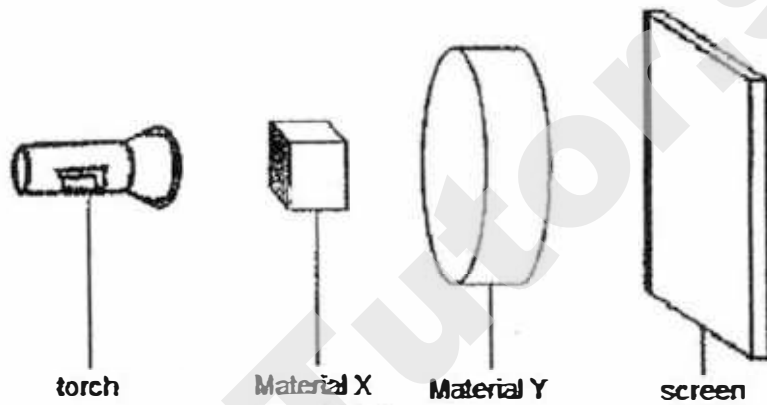

Which of the following is likely the shadow formed on the screen?

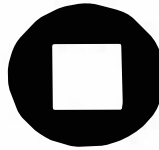
- (1) 
- (2) 
- (3) 
- (4) 

- 23 The table below shows the freezing points and boiling points of three unknown substances, P, Q and R.

Substance	Freezing point (°C)	Boiling point (°C)
P	40	85
Q	8	88
R	28	70

Which of the substances, P, Q and/or R, is/are liquid at 75°C?

- (1) P only
 - (2) R only
 - (3) P and Q only
 - (4) Q and R only
- 24 In the diagram below, a T-shaped tube with two drops of ink was attached to a conical flask by a rubber stopper. The flask was then immersed in a tub filled with ice cubes.

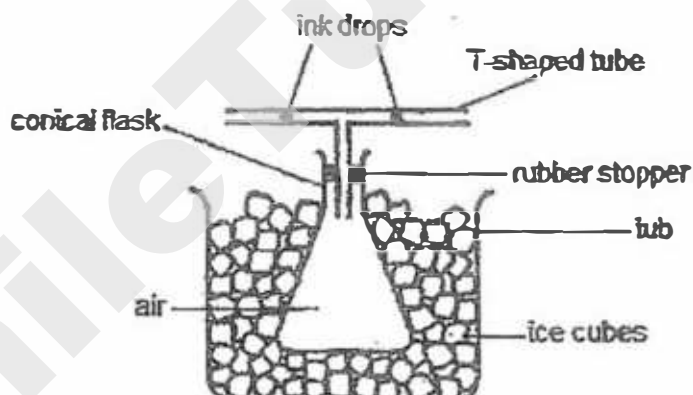

What will happen to the ink drops after 20 minutes?

- (1) The ink drops will gain heat and expand.
- (2) The ink drops will move towards each other.
- (3) The ink drops will move away from each other.
- (4) The ink drops will remain at the same position.

- 25 Beaker A contained 200ml of water with temperature at 50°C. Beaker B contained 200ml of water with a temperature at 90°C. Jayden poured an equal amount of water from Beaker A and Beaker B into Container X.

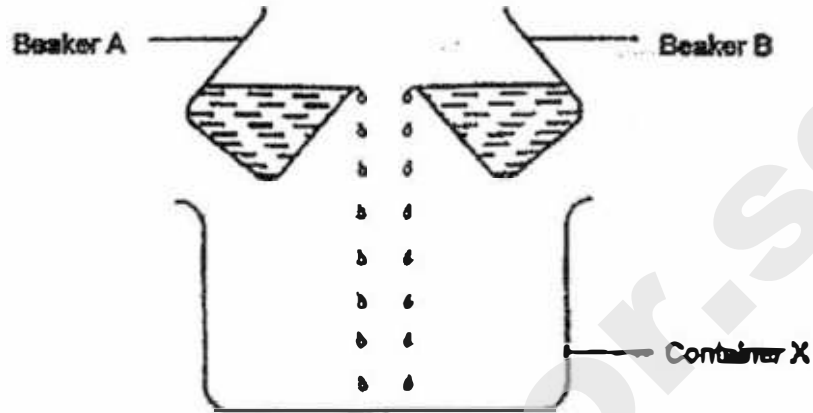

Which of the following statement(s) is/are true?

- A The temperature of water in Container X will be more than 90°C.
 - B The temperature of water in Container X will be less than 90°C but more than 50°C.
 - C The water from Beaker A will gain heat when mixed with the water from Beaker B.
 - D The water in Beaker A contained less heat than the water in Beaker B before they were poured into Container X.
- (1) A and B only
 - (2) B and D only
 - (3) A, C and D only
 - (4) B, C and D only

End of Booklet A

SEMESTRAL ASSESSMENT 1 (2017)

PRIMARY 5

SCIENCE

BOOKLET B

Wednesday

17 May 2017

1 hr 30 min

Name: _____ (Class: 5.)

INSTRUCTIONS TO PUPILS

- 1 Do not turn over the pages until you are told to do so.
- 2 Follow all instructions carefully.
- 3 There are 13 questions in this booklet.
- 4 Answer ALL questions.
- 5 The marks are given in the brackets [] at the end of each question or part question.

Booklet	Possible Marks	Marks Obtained
A	50	
B	40	
PBA	10	
Total	100	

Question paper consists of 14 printed pages (inclusive of cover page).

Booklet B (40 marks)

For questions 28 to 38, write your answers in this booklet.

The number of marks awarded is shown in the brackets [] at the end of each question or part question.

- 28 Tom carried out an experiment by putting two identical slices of bread J and K into identical plastic bags at room temperature. He sprinkled some water onto bread K before sealing both plastic bags. The diagram below shows the condition of the two slices of bread after 3 days. He observed mould growing on bread K.

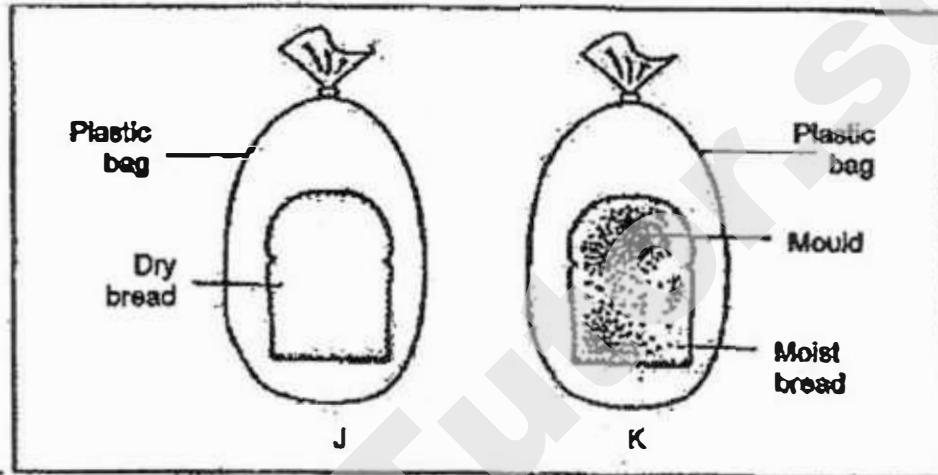

- (a) What was Tom trying to find out from the above experiment? [1]
- _____
- _____
- (b) Where did the mould in the above experiment obtain its food from? [1]
- _____
- _____
- (c) What will be the likely result of Tom's experiment if bread K was placed in the freezer for 2 weeks instead of at room temperature? [1]
- _____
- _____

(Go on to the next page)

SCORE	
	3

27 The diagram below shows the life cycles of two animals, the cockroach and the beetle.

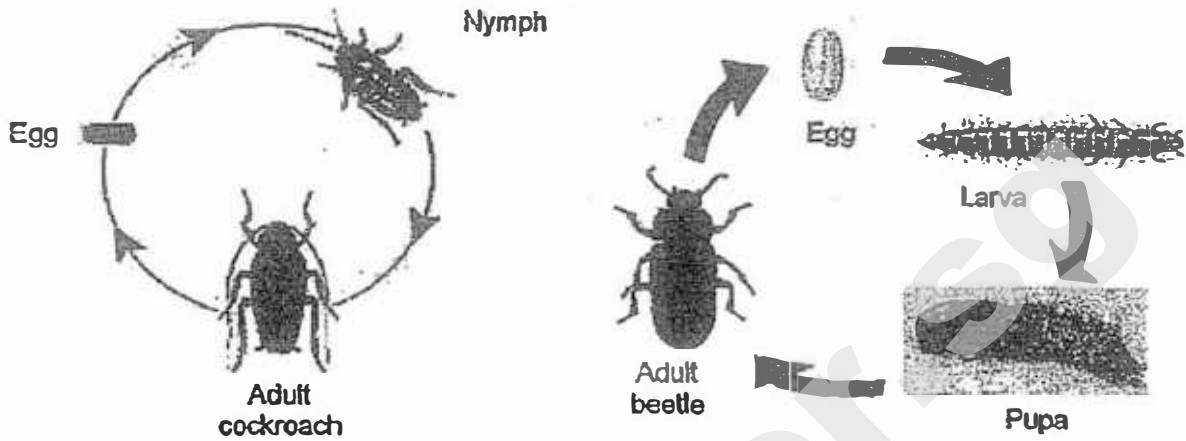

(a) Based on the life cycles above, state one similarity and one difference between the life cycles of both animals. [2]

(i) Similarity:

(ii) Difference:

(b) Name another animal that has the same number of stages in its life cycle as the adult beetle. [1]

(Go on to the next page)

SCORE	3
-------	---

28 Mary fills a measuring cylinder completely with sand as shown in the diagram above.

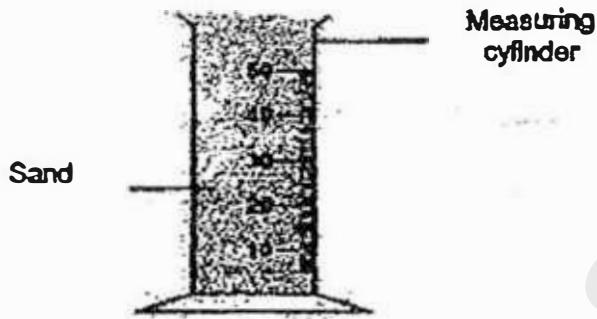

Some water is poured slowly from a beaker into the measuring cylinder until it reaches the brim of the measuring cylinder. When Mary was pouring the water, she noticed some bubbles forming on the surface of the water in the measuring cylinder.

- (a) Identify the state(s) of matter inside the measuring cylinder before Mary poured the water in. [1]

- (b) Explain why bubbles formed on the surface of the water in the measuring cylinder when Mary poured the water in. [2]

(Go on to the next page)

SCORE	/
	3

- 29 Jack set up an experiment as shown below. When he placed a thin piece of sheet X between the magnet and the paper clip, he noticed that the paper clip continued to be suspended in the air.

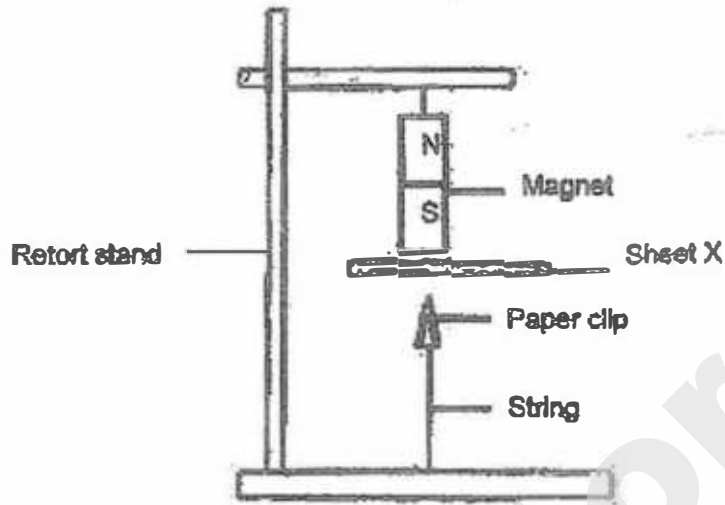

- (a) Based on the above experiment, state a property of sheet X. [1]

- (b) What material can the paper clip be made of that allows it to be suspended in the air? Explain your choice. [1]

(Go on to the next page)

SCORE	2
-------	---

30 Jack set up an experiment as shown below.

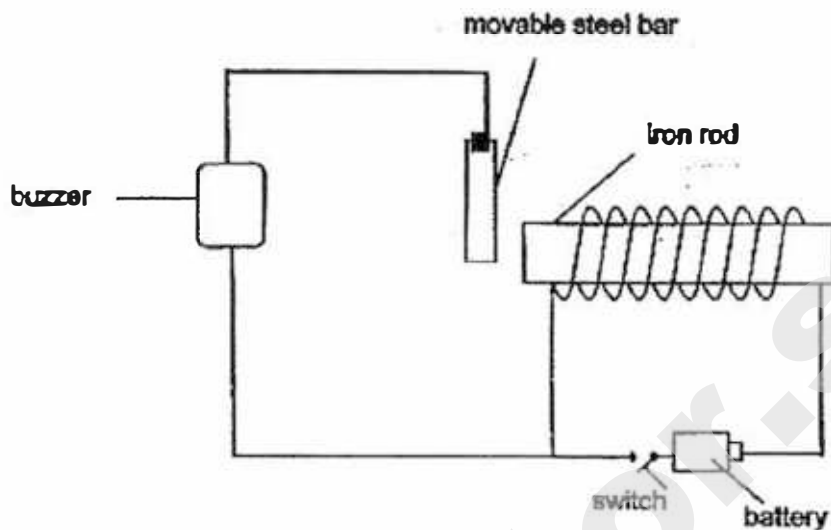

(a) When the switch in the circuit is closed, the buzzer produces a sound. Explain how this happens. [2]

(b) Jack replaced the steel bar with a gold bar. Describe what he would observe. [1]

(Go on to the next page)

SCORE	3
-------	---

31 Gabriel placed two plants in identical containers containing water as shown below. A layer of oil was added to the water in each container. He placed both set-ups in the same location.

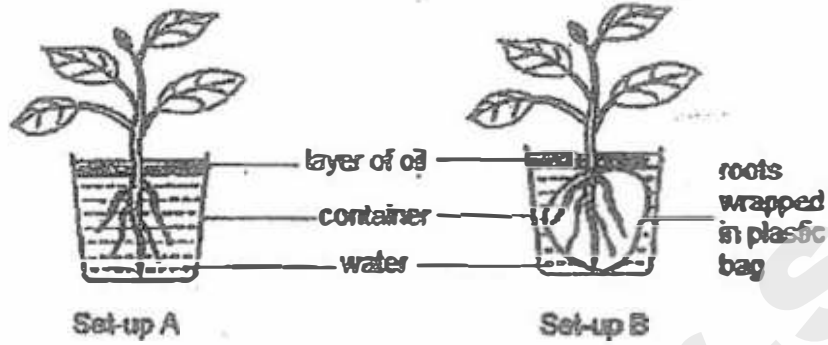

The next day, Gabriel noticed that the water level in Set-up A was lower than the water level in Set-up B.

(a) What was Gabriel trying to find out in the experiment? [1]

(b) State two other variables Gabriel must keep constant in order for his experiment to be a fair one. [1]

(Go on to the next page)

SCORE	
-------	---

32 The arrows in the diagram below shows the movement of substance X in the plant.

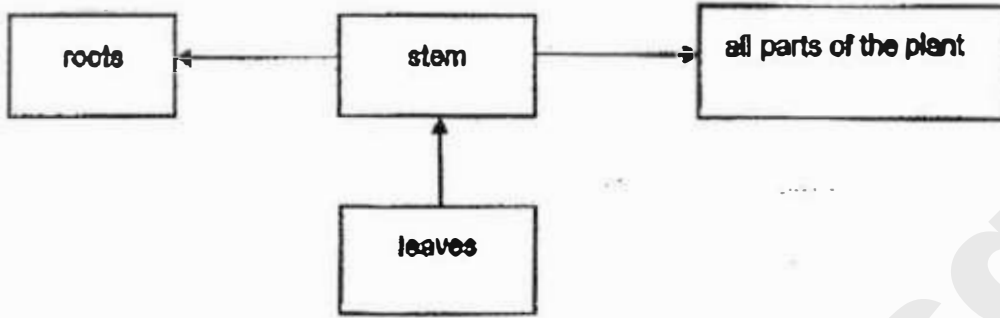

(a) What is substance X? [1]

(b) Jack had an apple tree in his garden. It was observed that part of the tree was destroyed by pests soon after.



The part of the trunk above the destroyed bark became swollen.

Based on the diagram above, explain why the part of the trunk became swollen. [2]

(Go on to the next page)

SCORE	
-------	--

33 In the lungs, the air tubes branch into tiny tubes that end in air sacs. The air sacs are surrounded by tiny blood vessels. The exchange of gases in the lungs takes place between the air sacs and the blood vessels.

The diagram below shows a section of an air sac in a lung of a human.

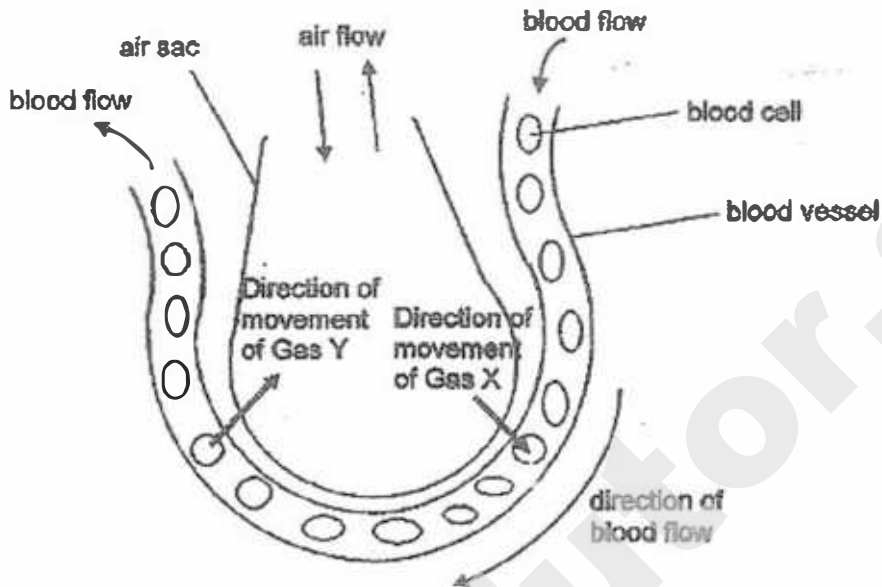

The diagram shows that Gas X leaves the air sac and enters the blood vessel and Gas Y enters the air sac and leaves the blood vessel.

(a) Name both Gas X and Gas Y. [1]

Gas X: _____

Gas Y: _____

(b) Other than Gas X and Gas Y, name two other substances that will be transported in the blood in the human organ systems. [1]

(c) Mr Tan is seated on the sofa reading newspapers. Name two outdoor activities that will increase the rate of exchange of gases in his lungs. [1]

(d) Why does Mr Tan's heart need to pump faster during these two outdoor activities? [1]

(Go on to the next page)

SCORE	4
-------	---

34 Study the flowchart given below carefully.

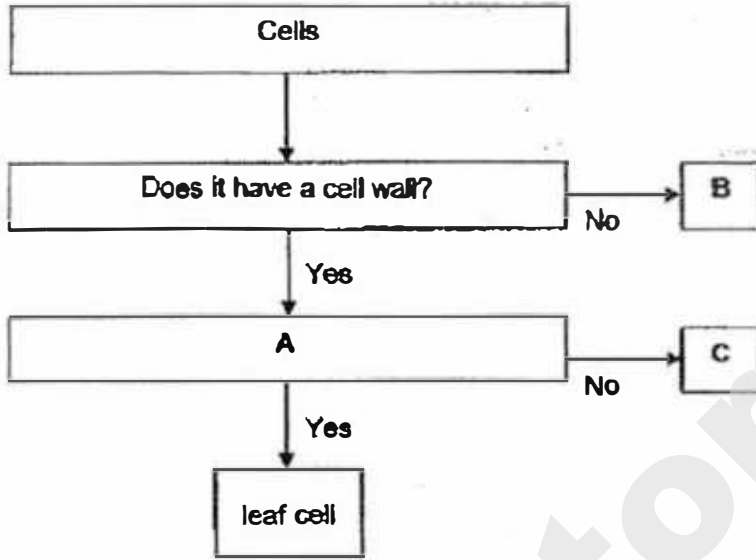

(a) Is B an animal cell or plant cell? Explain your answer. [1]

(b) Complete the flowchart. Write a suitable question for A. [1]

(c) Give an example of C and explain your answer. [1]

(d) What are the similarities in the cell structure of B and the leaf cell? [1]

(Go on to the next page)

SCORE	4
-------	---

35 Denzel set up two circuit diagrams, A and B as shown below.

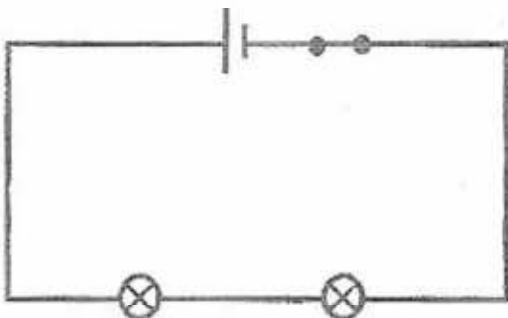

Circuit A

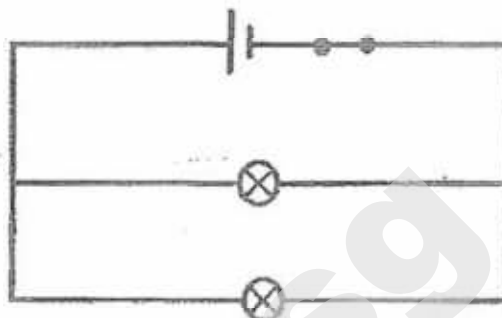

Circuit B

The graph below shows the relationship between the number of batteries and the brightness of the bulbs based on the above set-ups.

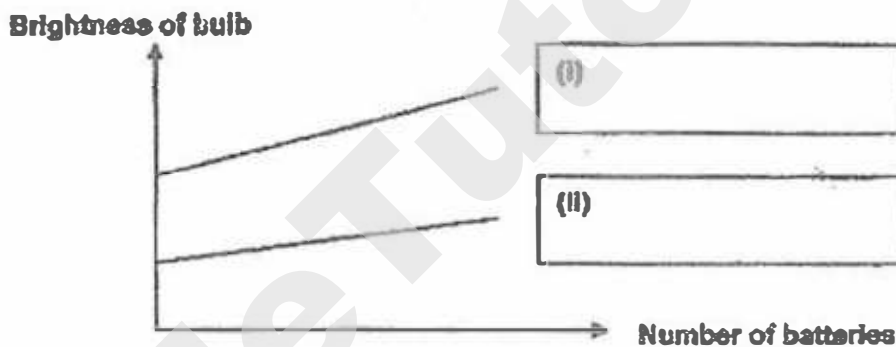

(a) In the graph above, match the line graphs to Circuit A and Circuit B. Write [1]
Circuit A and Circuit B in the boxes next to (i) and (ii).

(b) What can Denzel do to make the bulbs in Circuit B brighter? [1]

(c) Explain clearly what can be done to Circuit B if he wants to control the light bulbs individually. [1]

(Go on to the next page)

SCORE	3
-------	---

- (d) In the diagram below, draw in the wires to show how you can connect the batteries and the bulbs so that the bulbs will light up the brightest. [1]

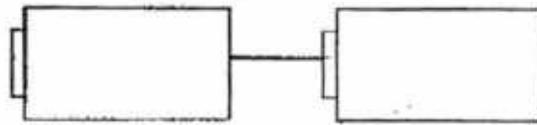

- (e) What will happen to your circuit in (d) if one of the bulb fuses? [1]

38 Look at the two circuits shown below.

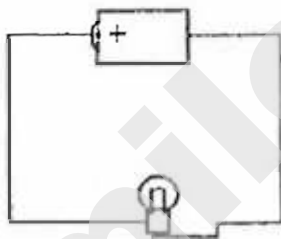

Circuit A

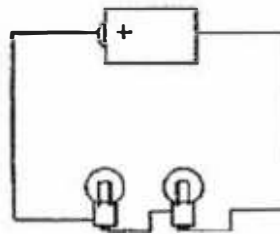

Circuit B

- (a) In which circuit will the bulbs light up more brightly? Give a reason for your answer. [1]

- (b) Give one disadvantage of arranging the bulbs in the way as shown in Circuit B. [1]

(Go on to the next page)

SCORE	4
-------	---

37 Jonathan wanted to find out which material loses heat the fastest. He conducted an experiment on containers made of different material (X, Y and Z) and filled each with the same amount of water at the same temperature. He placed all the containers at the same location.

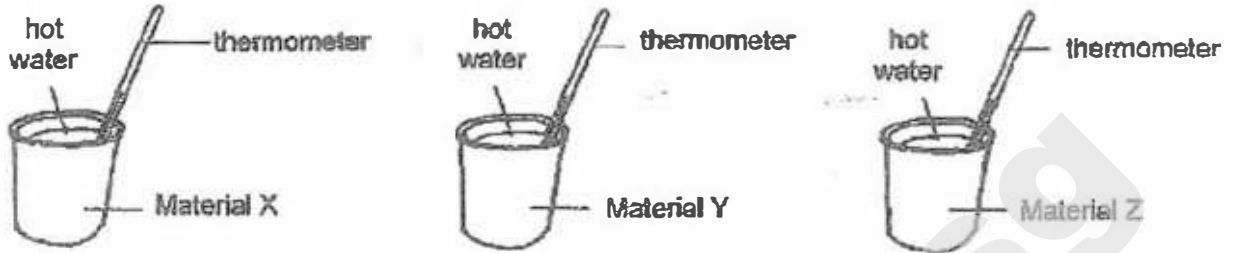

The temperatures in each container were taken at five-minute intervals and recorded in the graph below.

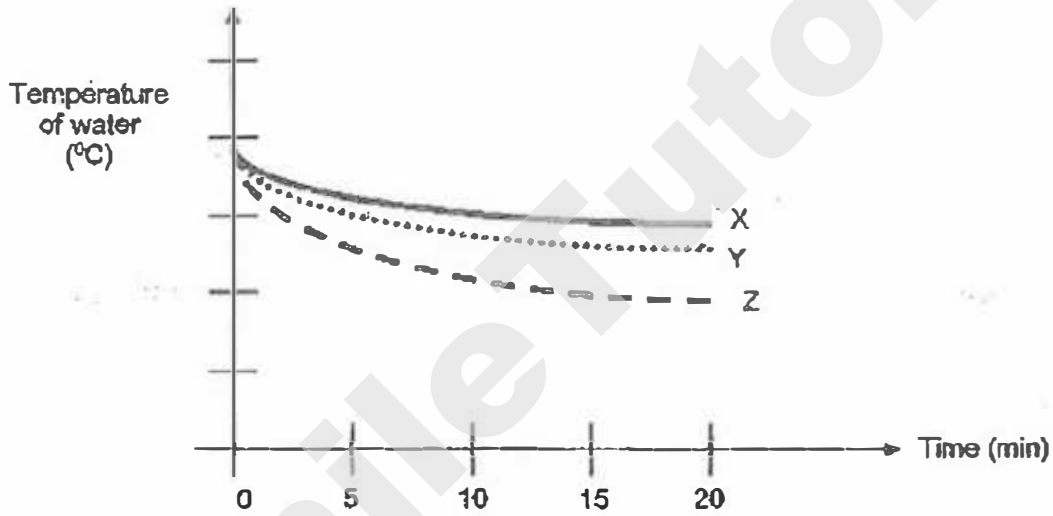

(a) Which material is the best conductor of heat? Explain your answer. [1]

(b) Based on the experiment, which material is the most suitable for making containers to keep ice-cream cold for the longest period of time? Explain your answer. [2]

(Go on to the next page)

SCORE	3
-------	---

38 Jonas conducted an experiment to find out about the heat conductivity of different materials. He placed some wax at the top end of 3 rods made of different materials, A, B and C. The three rods were then placed on top of a hot plate as shown below.

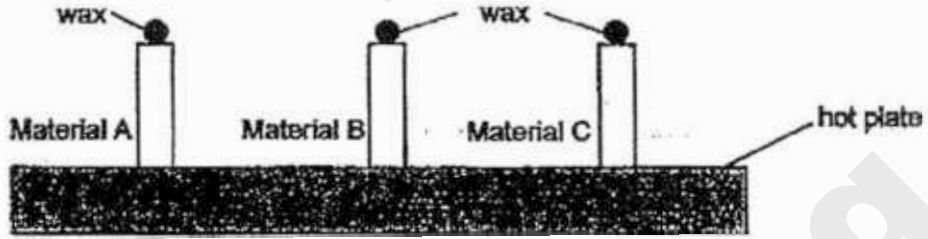

He recorded the time taken for the wax to melt completely at the top end of each rod and recorded them in the table below.

Material	A	B	C
Time taken (min)	16	4	22

(a) What can Jonas conclude about the heat conductivity of materials A, B and C? [1]

(b) List 2 other variables that Jonas needs to keep constant to ensure that the experiment is fair. [1]

(c) The diagram below shows a frying pan.

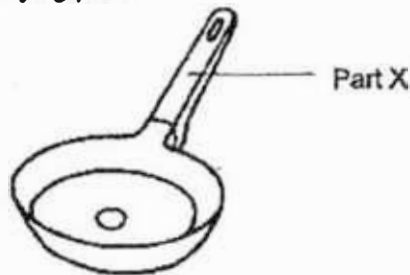

Based on the results of the experiment, which material is most suitable for making Part X of the frying pan? Explain your answer. [1]

End of Paper

SCORE	3
-------	---

SCHOOL : ANGLO-CHINESE PRIMARY SCHOOL
 LEVEL : PRIMARY 5
 SUBJECT : SCIENCE
 TERM : 2017 SA1

SECTION A

Q 1	Q2	Q3	Q4	Q5	Q6	Q7	Q8	Q9	Q10
4	3	3	3	1	1	4	2	4	2

Q 11	Q12	Q13	Q14	Q15	Q16	Q17	Q18	Q19	Q20
1	2	4	2	2	2	3	2	4	3

Q 21	Q22	Q23	Q24	Q25			
3	2	1	2	4			

SECTION B

Q26)	(a) Tom was trying to find out if mould needs water. (b) The mould obtains its food from the moist bread. (c) Bread k will not have mould growing on it.
Q27)	(a) (i) Both have egg-stage. (ii) A cockroach has 3-stage lifecycle while a beetle have a 4-stage life cycle. (b) Butterfly
Q28)	(a) Gas and solid. (b) As the sand is a solid, it has a fixed shape. It will not occupy the air spaces in between. When water was poured in, the water will occupy the space previously occupied by air, water poured in fills the spaces previously occupied by air, air then escapes and bubbles are formed.
Q29)	(a) It allows magnetic force to pass through. (b) Cobalt. It is a magnetic material, the magnet will attract the paper clip and therefore the paper clip will be suspended in the air. (note: paper clip can be made of any magnetic material, as magnetic material can be attracted to the magnet)
Q30)	(a) When the switch in the circuit is closed, the battery will let the electricity

	<p>flow to the wire, the wire coiled around the iron rod will allow the iron bar to be a partial electro-magnet, the iron will then attract the movable steel bar and now electric current could flow to the buzzer and the buzzer will produce a sound as there is a closed circuit.</p> <p>(b) The iron rod would not attract the gold bar and therefore the buzzer will not produce any sound.</p>
Q31)	<p>(a) If the roots absorb water.</p> <p>(b) The plant must be of the same type. The amount of water must be the same.</p>
Q32)	<p>(a) Food.</p> <p>(b) As one part of the phloem was removed, the food made by the leaves was not able to be transported to the lower part of the plants as the food-carrying tube (phloem) was destroyed.</p>
Q33)	<p>(a) Oxygen, Carbon dioxide</p> <p>(b) Digested food and water.</p> <p>(c) Running or swimming.</p> <p>(d) To pump blood that has more digested food and oxygen.</p>
Q34)	<p>(a) Animal cell. It does not have a cell wall.</p> <p>(b) Does it have chloroplast?</p> <p>(c) Root cell. It does not need chloroplast as it does not make food.</p> <p>(d) Both have nucleus, cell membrane and cytoplasm.</p>
Q35)	<p>(a) (i) Circuit B (ii) Circuit A</p> <p>b. Add more batteries</p> <p>c. A switch could be placed on both right side of the bulb</p> <p>d.</p> <div style="text-align: center;"> </div> <p>e. The other bulb will not light up.</p>
Q36)	<p>(a) Circuit A. Both circuits have one battery but there is only one bulb in circuit A and there are 2 bulbs in circuit B. Hence circuit A need not share the electricity.</p> <p>(b) If one of the bulbs fuses. the other bulb will not light up.</p>
Q37)	<p>(a) Z. It allows heat lost in the shortest amount of time.</p> <p>(b) X. It is the poorest conductor of heat and the ice-cream will gain the least heat.</p>
Q38)	<p>(a) B is the best conductor of heat, A is the second best conductor and C is the worst conductor of heat.</p> <p>(b) The wax must be of the same kind. The rods must be of the same height.</p> <p>(c) C. It took the longest time to gain heat so it is the poorest conductor of heat.</p>

SEMESTRAL ASSESSMENT ONE

(2017) PRIMARY FIVE

SCIENCE

BOOKLET A

Name: _____ ()

Class: Primary 5 - _____

Date: 9 May 2017

28 questions

56 marks

Total Time for Booklets A and B: 1 hour 45 minutes

INSTRUCTIONS TO CANDIDATES

Do not turn over this page until you are told to do so.

Follow all instructions carefully.

Answer all questions.

Shade your answers in the Optical Answer Sheet (OAS) provided.

This booklet consists of 21 printed pages, excluding the cover page.

Booklet A (28 × 2 marks)

For each question from 1 to 28, four options are given. One of them is the correct answer. Make your choice (1, 2, 3 or 4). Shade your answer on the Optical Answer Sheet. (56 marks)

1 The diagram below shows how animals A, B, C and D are classified.

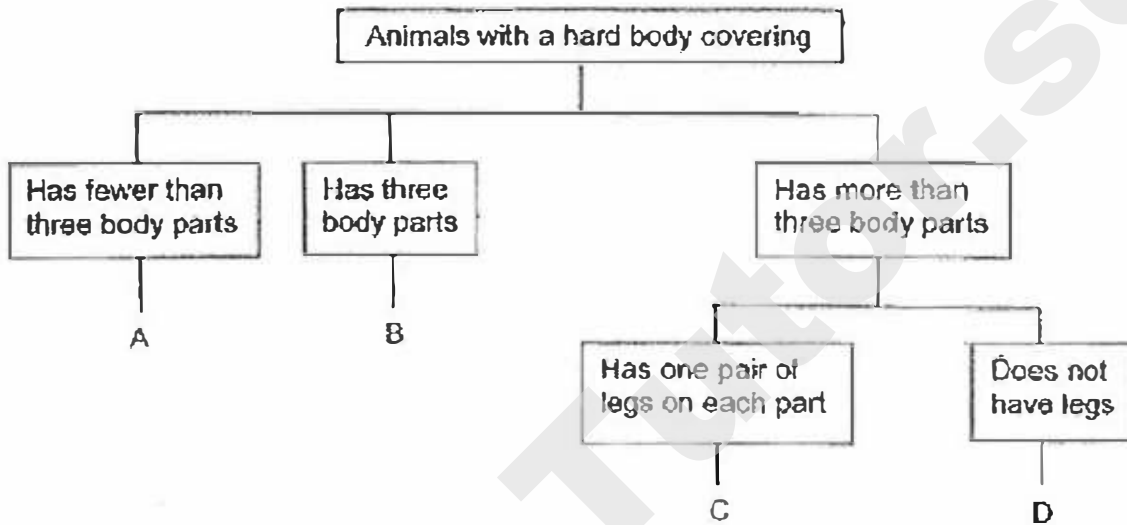

Jacky found an animal as shown below. He noted that the animal had a hard body covering.



Which one of the following, A, B, C or D, best represents the above animal?

- (1) A
- (2) B
- (3) C
- (4) D

- 2 Which one of the following comparisons between non-flowering plants and fungi is correct?

	Non-flowering plants	Fungi
(1)	can bear fruits	cannot bear fruits
(2)	can make food	cannot make food
(3)	can be pollinated	cannot be pollinated
(4)	can reproduce by spores	cannot reproduce by spores

- 3 Which one of the following does not describe the function of a plant part correctly?

	Plant parts	Function
(1)	stem	transports water only
(2)	roots	anchor the plant to the ground
(3)	leaves	make food
(4)	flowers	attract animals for pollination

4 The diagram below shows what happens in the human digestive system.

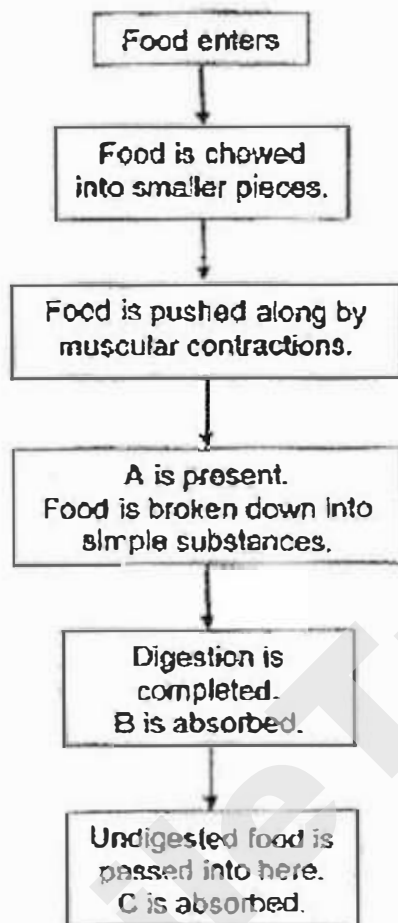

Based on the information given above, what do A, B and C represent?

	A	B	C
(1)	nutrients	water	digestive juice
(2)	nutrients	digestive juice	water
(3)	digestive juice	nutrients	water
(4)	digestive juice	water	nutrients

5 The diagram shows an insect.



Which of the following animals have the same number of stages in their life cycles as the insect above?



mosquito



grasshopper



chicken



frog

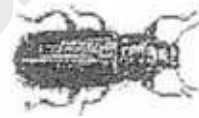

mealworm beetle

- (1) chicken and frog only
- (2) mosquito and grasshopper only
- (3) mosquito and mealworm beetle only
- (4) mosquito, grasshopper and mealworm beetle only

6 Which one of the following shows the order of stages and processes in the life cycle of a plant?

(1)

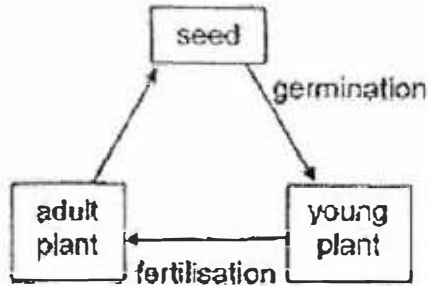

(2)

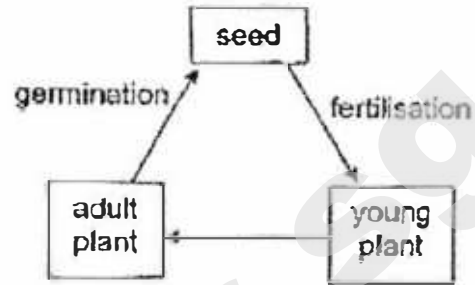

(3)

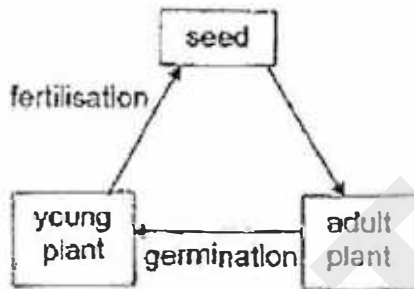

(4)

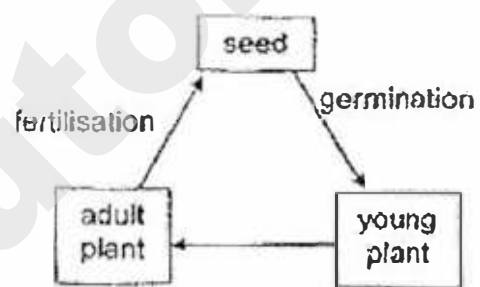

7 The diagram below shows the cross-section of a flower.

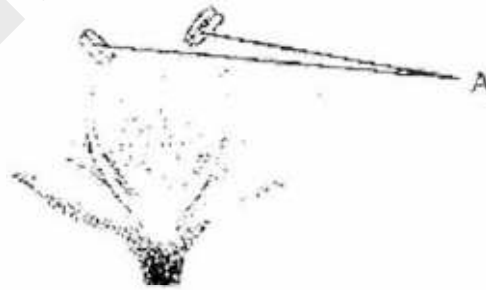

What will happen to the flower if A is cut off?

- A The flower will die.
- B Fertilisation will not take place.
- C The flower cannot produce pollen grains.

- (1) A only
- (2) C only
- (3) A and B only
- (4) B and C only

- 8 . Jackie conducted an experiment on Flower K which he found in the park near his home.

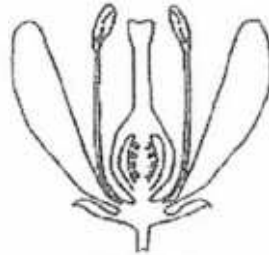

Flower K

He took three such flowers and removed some parts from each flower as shown below.

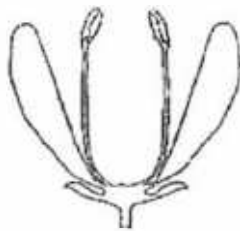

Flower 1



Flower 2



Flower 3

Next, he dusted pollen from Flower K onto each of the above Flowers 1, 2 and 3. He observed the flowers over the next few weeks.

Which of the flower(s) will not develop into fruits?

- (1) Flower 1 only
- (2) Flower 2 only
- (3) Flowers 2 and 3 only
- (4) Flowers 1, 2 and 3

- 9 Kate mapped the location of plants P, Q and R in an area as shown below.

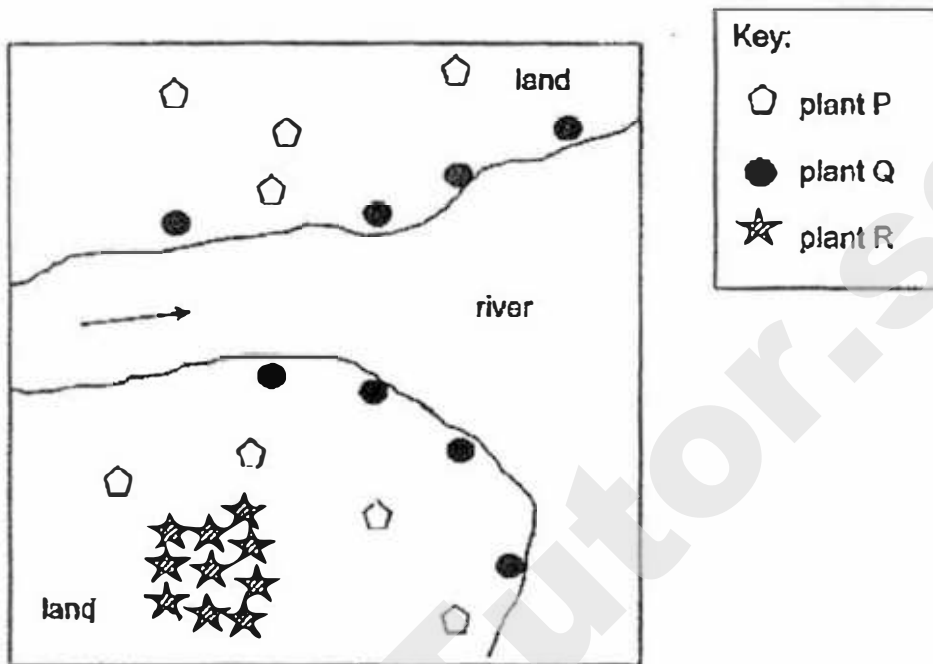

Kate found the following fruits in the same area.

Fruit X



Fruit Y



Fruit Z

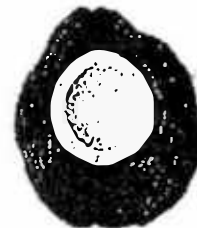

Which of the following correctly matches each fruit to its parent plant?

	Fruit X	Fruit Y	Fruit Z
(1)	plant P	plant Q	plant R
(2)	plant R	plant P	plant Q
(3)	plant Q	plant P	plant R
(4)	plant P	plant R	plant Q

- 10 Tom conducted an experiment using some similar seeds and planted them in different types of soil over two weeks. The size of the pots and the amount of soil have been kept the same. He recorded his experiment in the table as shown below.

Pot	Type of soil	Amount of water given daily (cm ³)	Number of seeds planted	Average height of seedlings after 2 weeks (cm)
P	Garden	100	10	5.0
Q	Sandy	100	20	9.5
R	Garden	100	20	7.5
S	Sandy	100	10	6.0

Which of the following are possible aims for Tom's experiment?

- A To find out if overcrowding affects the average height of seedlings.
- B To find out if the average heights of seedlings affect the growth of seedlings.
- C To find out if different types of soil used affect the average height of seedlings.
- D To find out if different amounts of water given daily affect the average height of seedlings.

- (1) A and C only
- (2) A and D only
- (3) B and C only
- (4) B and D only

- 11 The table below shows the physical characteristics of Angie and her parents, Mr. and Mrs. Chia.

	Physical Characteristics			
	Earlobes	Eyelids	Dimples	Hair length
Mr. Chia	Detached	Single	Yes	Short
Mrs. Chia	Attached	Double	No	Short
Angie	Attached	Double	Yes	Short

How many characteristics did Angie inherit from her parents?

- (1) She inherited one from her father and one from her mother.
- (2) She inherited one from her father and two from her mother.
- (3) She inherited two from her father and one from her mother.
- (4) She inherited two from her father and three from her mother.

12 Which one of the following statements is incorrect about sexual reproduction in both flowering plants and humans?

- (1) Pollination must take place before fertilisation.
- (2) Sexual reproduction involve male and female reproductive cells.
- (3) Fertilisation occurs when the male and female reproductive cells fuse
- (4) Characteristics are passed on from parents to their young through sexual reproduction.

13 Study Jeremy's family tree below. The family tree shows the members who have straight or curved thumbs.

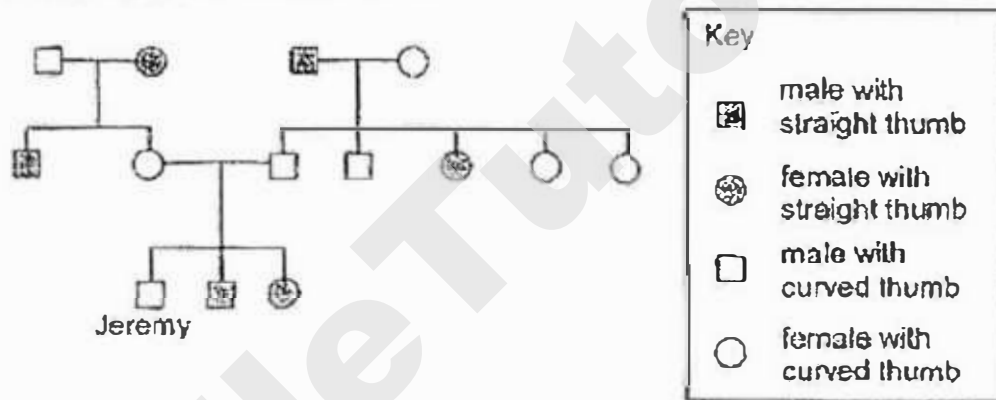

Which one of the following statements about Jeremy's family tree is correct?

- (1) Jeremy's parents have straight thumbs.
- (2) Both Jeremy and his sister have straight thumbs.
- (3) Both Jeremy's grandmothers have curved thumbs.
- (4) Jeremy's father has a brother with a curved thumb.

14 Study the classification chart below.

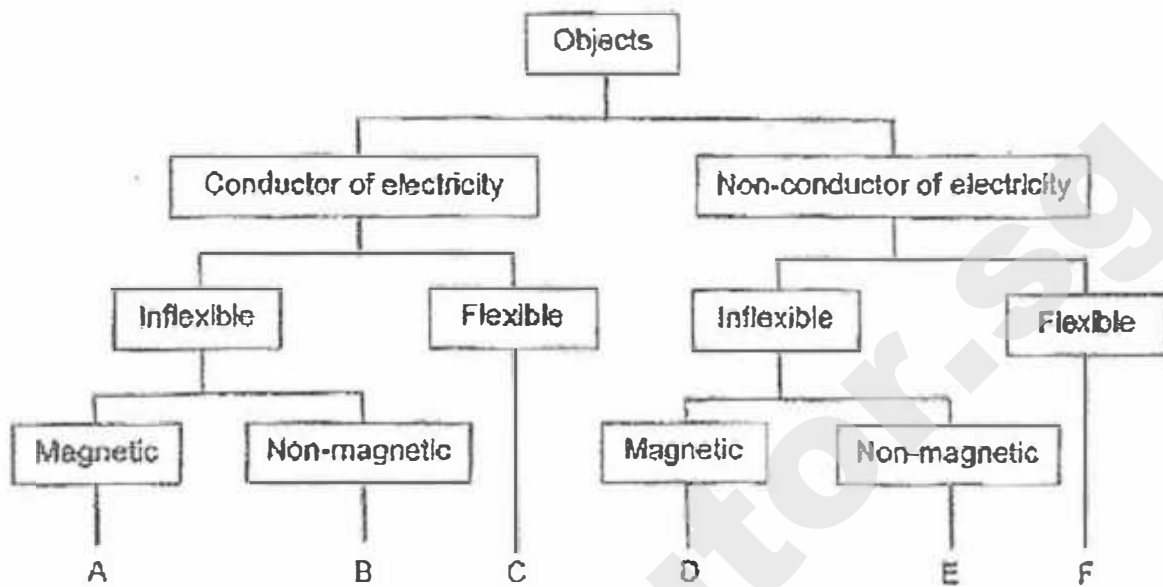

Which object, A, B, C, D, E or F, represent a steel nail and rubber hose?

	Steel nail	Rubber hose
(1)	A	F
(2)	A	E
(3)	B	F
(4)	C	D

- 15 The diagram below shows a freely-suspended metal bar B with ends labelled C and D. When magnet M is brought near bar B, bar B swings away in the direction as shown below.

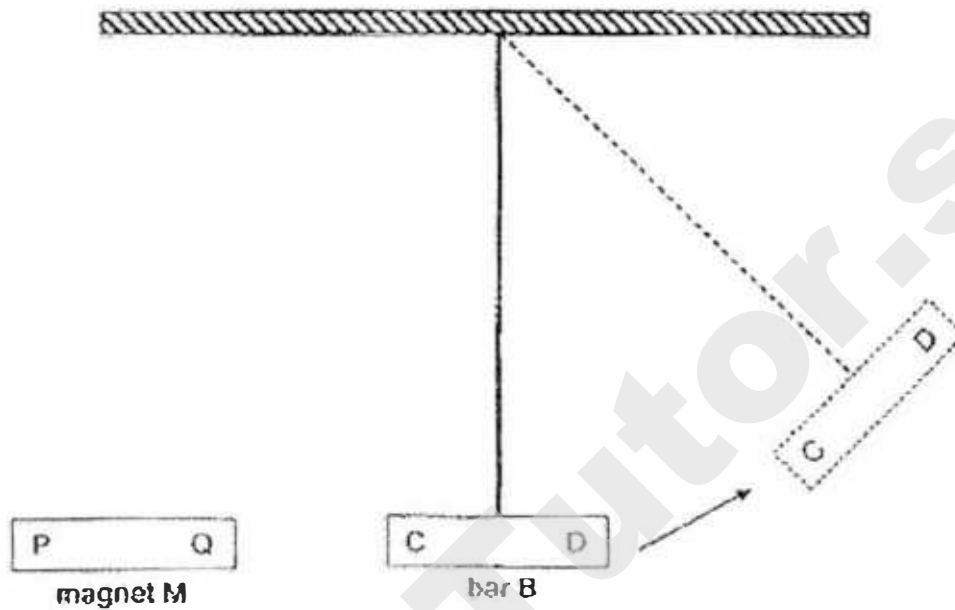

What can you conclude from this experiment?

- (1) Bar B is not a magnet.
- (2) Bar B is made of silver.
- (3) Ends Q and C are like poles.
- (4) Ends P and D are unlike poles.

- 16 Magnet A was strapped to toy car P. Tim wanted to test the strength of 4 magnets, W, X, Y and Z, of similar sizes. He moved magnet W closer to magnet A and recorded the distance travelled by car P. He then repeated the experiment with magnets X, Y and Z.

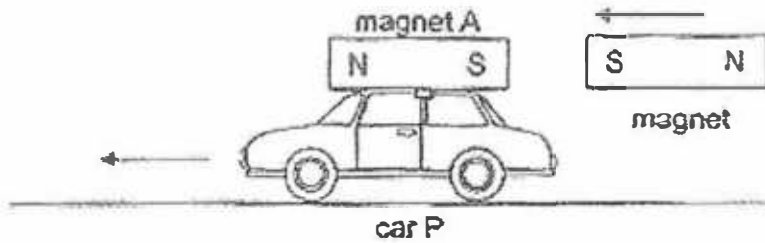

The distances travelled by car P are shown in the table below.

Magnet	Distance (cm)
W	8
X	14
Y	13
Z	20

Based on the results above, which magnet is the strongest?

- (1) W
- (2) X
- (3) Y
- (4) Z

- 17 Dennis conducted an experiment using the set-up as shown. The capacity of the container is 2000 cm^3 .

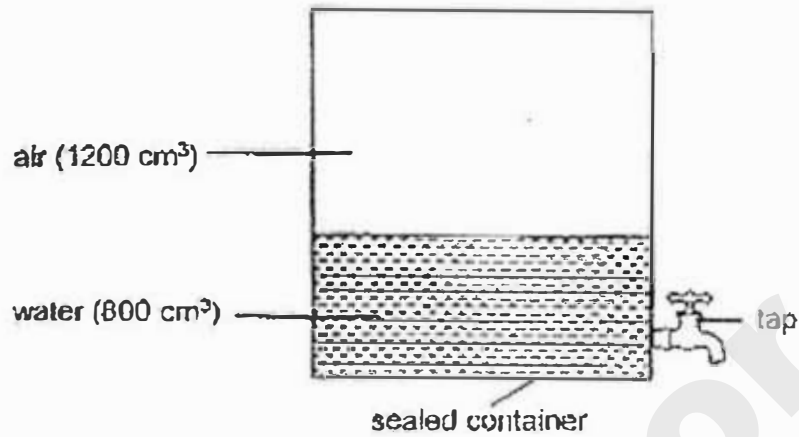

He used the tap to remove 500 cm^3 of water.

What was the volume of air in the container after 500 cm^3 of water was removed?

- (1) 800 cm^3
- (2) 1200 cm^3
- (3) 1700 cm^3
- (4) 2000 cm^3

- 18 A torch was used to shine at a mug made from a material that does not allow light to pass through. The mug was placed in different positions.



Which one of the following shadows could not be formed?

(1)



(2)



(3)



(4)



- 19 Four beakers, W, X, Y and Z, made of different materials but of similar size and thickness were filled with the same amount of water and the water was heated to boiling point using similar heat sources.

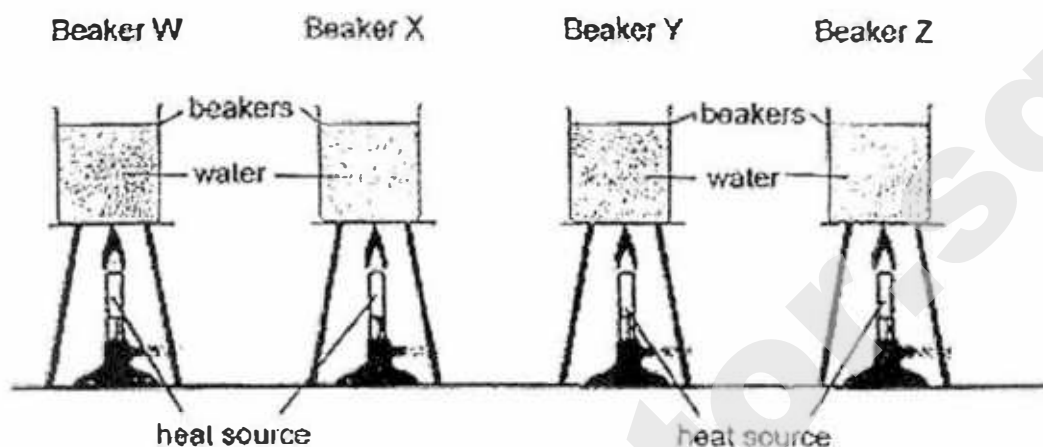

The table below shows the time taken for the water in each beaker to reach boiling point.

Beaker	Time (min)
W	22
X	9
Y	8
Z	14

Which of the following shows the likely material that each beaker was made of?

	Beaker W	Beaker X	Beaker Y	Beaker Z
(1)	iron	glass	ceramic	aluminium
(2)	glass	ceramic	aluminium	iron
(3)	aluminium	iron	glass	ceramic
(4)	ceramic	aluminium	iron	glass

- 20 A glass of water with some ice cubes were left on the table for half an hour.



Which of the following correctly shows the heat gain and heat loss taking place in the ice cubes, water in the glass and glass during the experiment?

	Ice cubes	Water in the glass	Glass
(1)	heat loss	heat loss	heat gain
(2)	heat gain	heat gain	heat loss
(3)	heat loss	heat gain	heat gain
(4)	heat gain	heat loss	heat loss

- 21 The diagram below shows the water cycle.

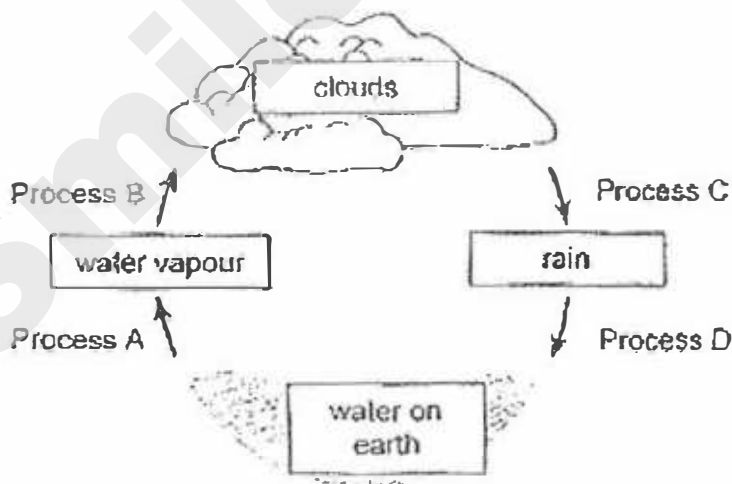

Which processes, A, B, C or D, represent evaporation and condensation?

	Evaporation	Condensation
(1)	A	B
(2)	B	A
(3)	C	D
(4)	D	C

- 22 A large metal container is separated by 2 similar metal sheets into 3 sections L, M and N. Each section is filled with 150 ml of water at different temperatures as shown. The room temperature is at 26°C.

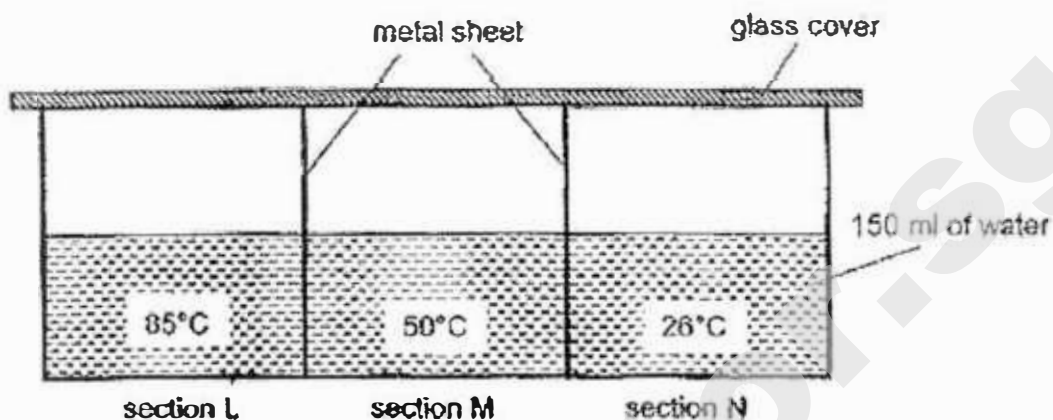

Which of the following statements are correct about what would be observed after a period of time?

- A Heat flows from section L to section M to section N.
- B Water in section M gains heat from water in section L.
- C Temperature of water in section N will drop after an hour.
- D More water droplets will be found under the glass cover in section L than in section M.

- (1) A and B only
- (2) A and C only
- (3) A, B and D only
- (4) B, C and D only

- 23 Linda heated a pot of tap water in her kitchen for 10 minutes until it started boiling. She continued boiling it for another 10 minutes before adding some vegetables into the water.

Which one of the following graphs shows the changes in the temperature of the water?

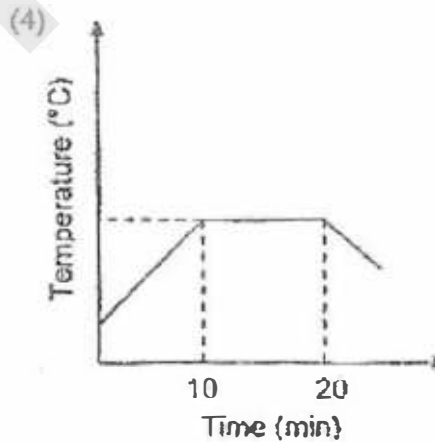
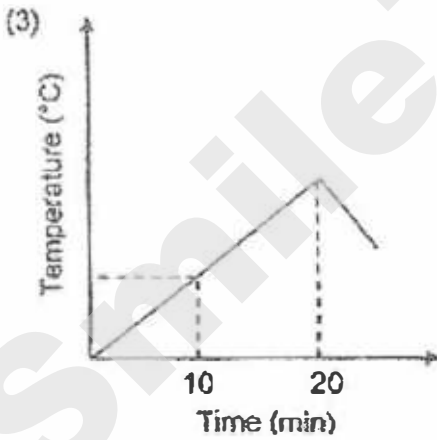
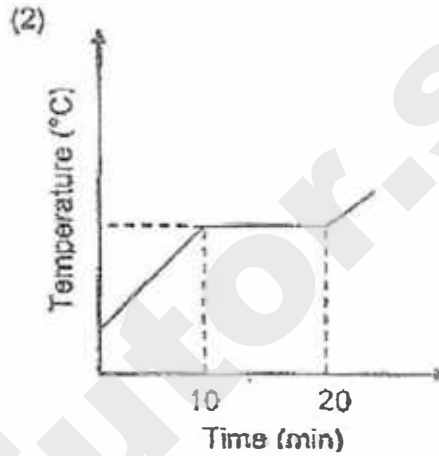
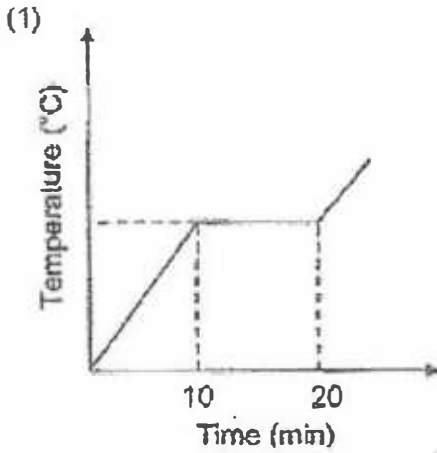

24 In which one of the following circuits will the bulb not light up?

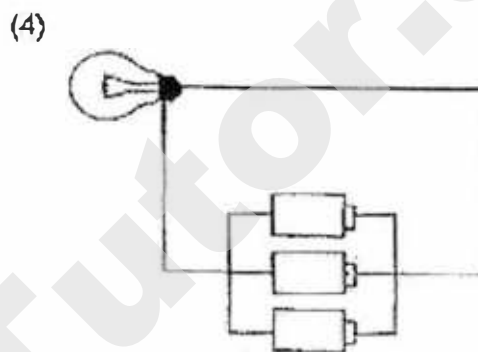
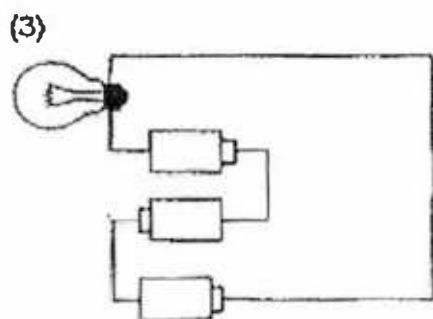
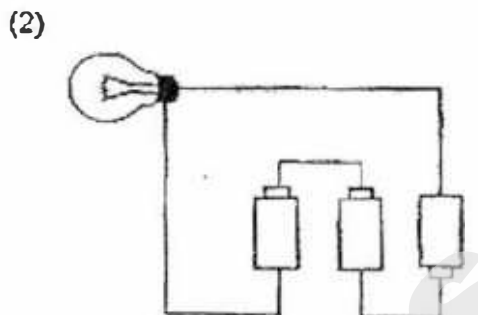
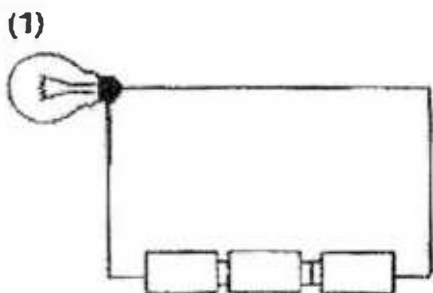

25 Study the circuit diagram below.

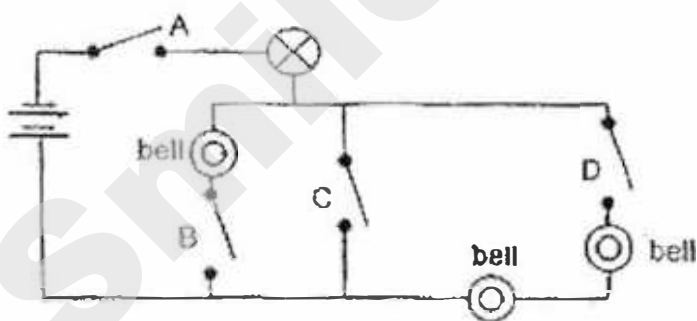

Which of the switches must be closed in order to light up only the bulb but not ring any bell?

- (1) A and C only
- (2) A and D only
- (3) B and C only
- (4) B and D only

- 26 Four materials, A, B, C and D, of similar size were connected in the electrical circuit as shown below.

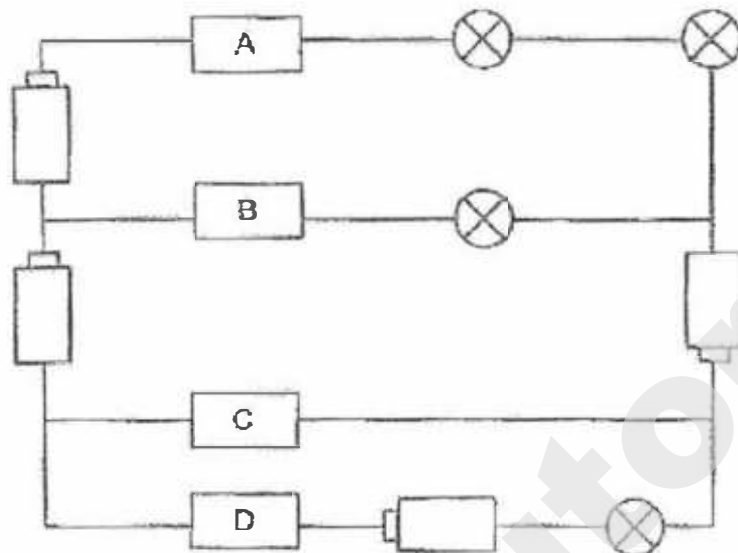

What could materials A, B, C and D be in the electrical circuit so that only two of the bulbs will light up?

	Material A	Material B	Material C	Material D
(1)	wood	copper	silver	plastic
(2)	plastic	silver	copper	wood
(3)	silver	plastic	copper	wood
(4)	copper	plastic	wood	silver

- 27 The diagram below shows four bulbs A, B, C and D connected correctly in a circuit.

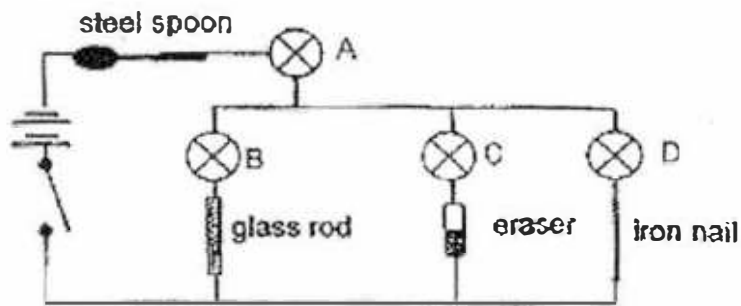

Which of the bulbs will light when the switch is closed?

- (1) A and D only
 - (2) B and C only
 - (3) A, B and C only
 - (4) A, B, C and D
- 28 Study the electrical circuit below.

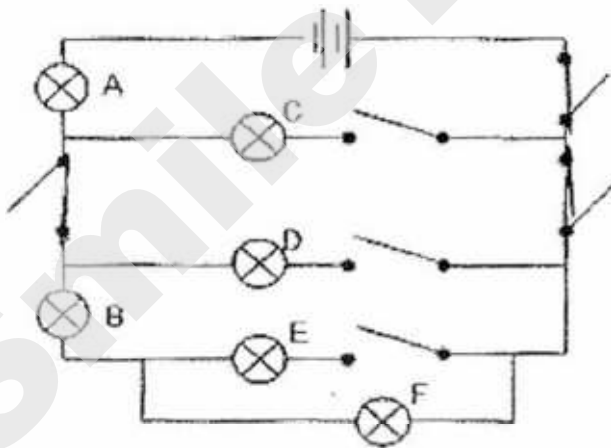

What is the minimum number of switches that has to be closed so that bulbs A, B and F will light up?

- (1) 3
- (2) 4
- (3) 5
- (4) 6

End of Booklet A

SEMESTRAL ASSESSMENT ONE

(2017) PRIMARY FIVE

SCIENCE

BOOKLET B

Name: _____ ()

Class: Primary 5 - _____

Date: 9 May 2017

Parent's Signature: _____

Booklet A	56
Booklet B	44
Total	100

13 questions

44 marks

Total Time for Booklets A and B: 1 hour 45 minutes

INSTRUCTIONS TO CANDIDATES

Do not turn over this page until you are told to do so.

Follow all instructions carefully.

Answer all questions.

Write your answers in this booklet.

This booklet consists of 17 printed pages, excluding the cover page.

Booklet B (44 marks)

For questions 29 to 41, write your answers in this booklet.

The number of marks available is shown in brackets () at the end of each question or part question. (44 marks)

29 Study the flow chart below.

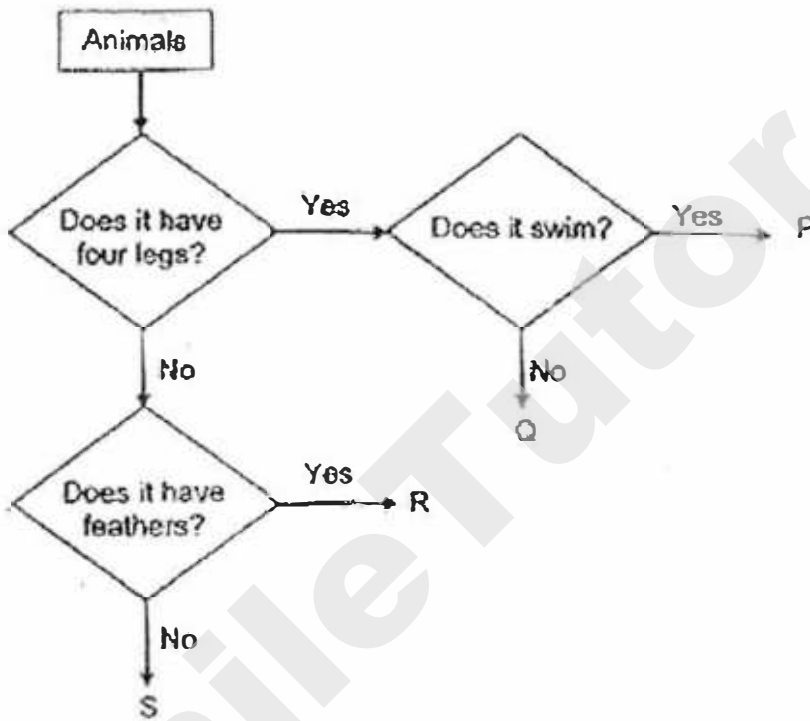

(a) Based on the flow chart above, write down the characteristics of animal Q. [1]

(b) How is animal Q different from animal R? [1]

(Go on to the next page)

SCORE	2
-------	---

30 The diagram below shows the human digestive s

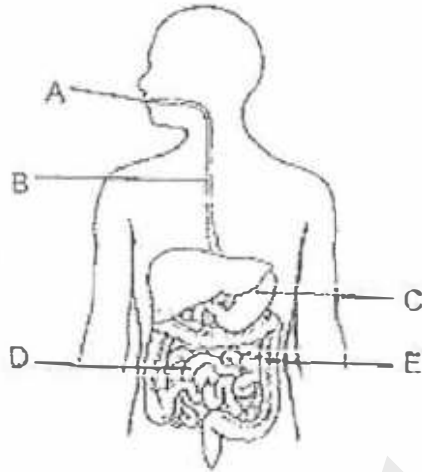

The graph below shows the amount of undigested food in each part of the digestive system just before it travels to the next part.

- (a) Draw bars to complete the graph to show the amount of undigested food at A and E. [1]



- (b) Explain what happened to the digested food at D. [1]

(Go on to the next page)

SCORE	2
-------	---

31 Look at the two life cycles below.

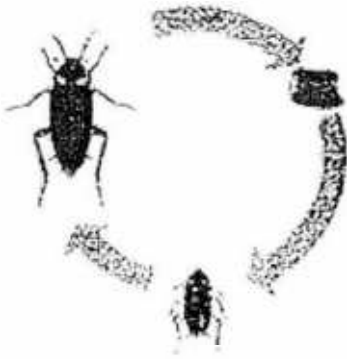

Life cycle of a cockroach



Life cycle of a butterfly

Compare their life cycles and state two differences.

{2}

- (i) _____

- (ii) _____

(Go on to the next page)

SCORE	2
-------	---

- 32 Audrey counted the number of two different types of young plants, M and N, at various distances from their parent plants in a field. The results are shown below.

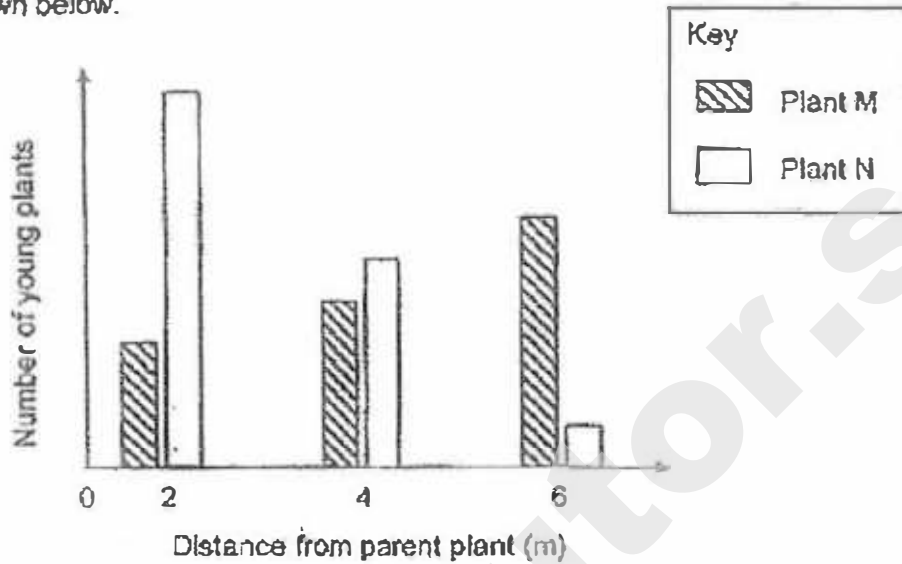

Which one of the following is likely to be the fruit of plant M? Choose your answer and put a tick (✓) in the box.





Explain your answer.

{2}

(Go on to the next page)

SCORE	2
-------	---

- 33 Mary had four rods, A, B, C and D, each made of different materials. She wanted to investigate the magnetic strength of each rod using the following set-up. The number of pins in the tray was 50.

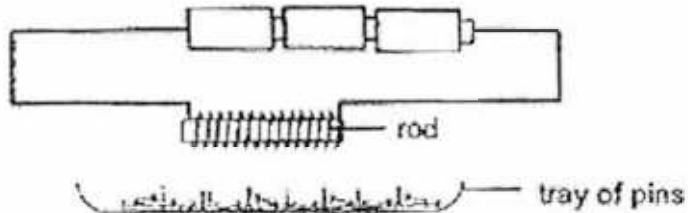

She placed Rod A 15 cm above the tray of pins and recorded the number of pins left in the tray. She repeated the experiment with Rods B, C and D. The number of pins left in the tray was recorded in the table below.

Rod	Number of pins left in the tray
A	32
B	28
C	35
D	21

- (a) Based on the table above, which rod was the strongest electromagnet when the switch was closed? Explain your answer. [1]

- (b) Without changing the set-up, what could Mary do so that there would be fewer pins left in the tray? [1]

- (c) When Mary replaced the rod with rod Q, she observed that the number of pins left in the tray was 50. Based on this observation, what can you tell about the property of rod Q? [1]

(Go on to the next page)

SCORE	3
-------	---

- 34 Jason filled a syringe with some water and then sealed the opening as shown below.

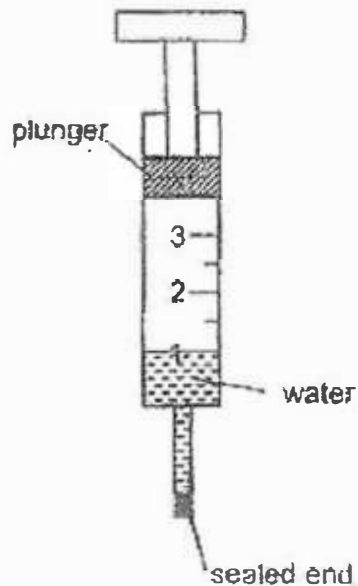

He then tried to push in the plunger.

- (a) What do you think would happen to the volume of air and water in the syringe when he pushed in the plunger? [2]

- (b) If Jason were to continue pushing the plunger in, would it reach the "1" mark on the syringe? Explain your answer. [1]

(Go on to the next page)

SCORE	3
-------	---

- 35 Zach conducted an experiment in a completely dark room to find out how well materials A, B and C allow light to pass through. He shone a torch at a screen made of the material A and recorded the amount of light that passed through the material using a light sensor attached to a datalogger. He then repeated the experiment using materials B and C one at a time.

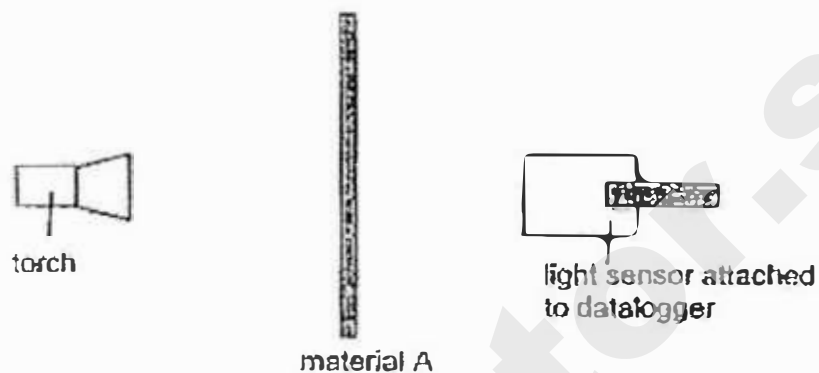

The graph below shows the results of Zach's experiment.

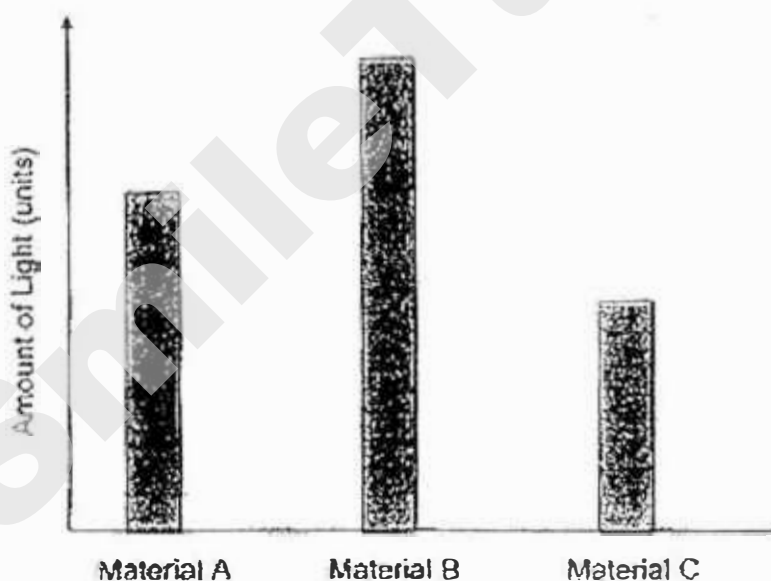

- (a) Give a reason why Zach should conduct his experiment in a completely dark room. [1]

(Go on to the next page)

SCORE	1
-------	---

Continue from question 35

- (b) The window of a shop is designed to allow passers-by to see the displays clearly.

Based on Zach's experiment, which material is most suitable for making the window of the shop? Explain your choice.

[2]

- (c) Draw light rays below to show how Zach's sister is able to see what she is drawing.

[1]



(Go on to the next page)

SCORE	3
-------	---

- 38 (a) Justin conducted an experiment by heating three similar rods made of metals U, V and W for 25 minutes. He recorded the lengths of each rod before and after the heating in the table below.

Metal	Length before heating (cm)	Length after heating (cm)
U	3	3.20
V	3	3.07
W	3	3.04

- (i) Based on the results of this experiment, what can Justin conclude about the effects of heating on different metals? [1]

- (ii) In another experiment, Justin heated a thinner rod made of metal U of length 3 cm for 25 minutes.

Would the rod take less than, equal to or longer than 25 minutes to reach the length of 3.2 cm? Give a reason for your answer. [2]

- (b) As Justin was walking across a bridge, he noticed that the bridge had special joints like the one shown in the picture below.

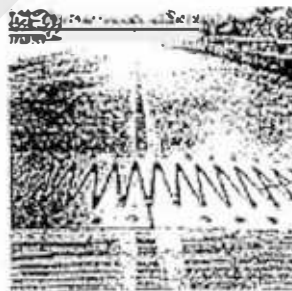

joints with gaps

Why do you think a bridge need joints with gaps in them? [2]

(Go on to the next page)

SCORE	5
-------	---

- 37 Mr. Chan was driving his son to school when he noticed that the windows of his car had become misty.

Temperature in the car : 18°C

Temperature of the surrounding air : 33°C

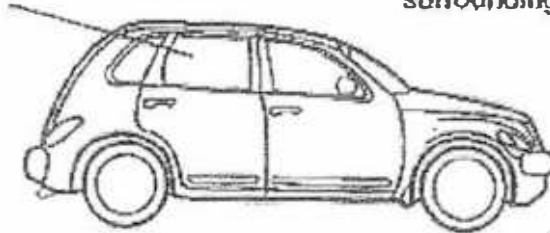

- (a) He observed that water droplets were formed on the outer surface of the car windows. Explain how the water droplets were formed. [2]

- (b) After he wound down one of the windows and switched off the air conditioner, water droplets stopped forming on the outer surface of the windows after a while. Explain why it happened. [1]

(Go on to the next page)

SCORE	3
-------	---

38 Some children washed a sweater and noticed that it felt heavier.

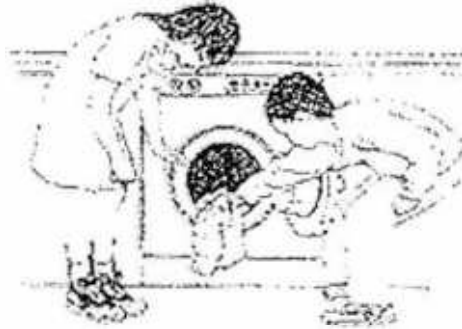

(a) Why was the sweater heavier after it was washed? [1]

(b) The children wanted to find out how long it took for the sweater to dry. They hung the sweater up in the garden on a sunny day to dry.



(i) Name the process that completely dries the sweater. [1]

(ii) State the change of state in (i). [1]

(Go on to the next page)

SCORE	3
-------	---

Continue from question 38

- (c) The children weighed the sweater every hour and plotted a graph with their results.

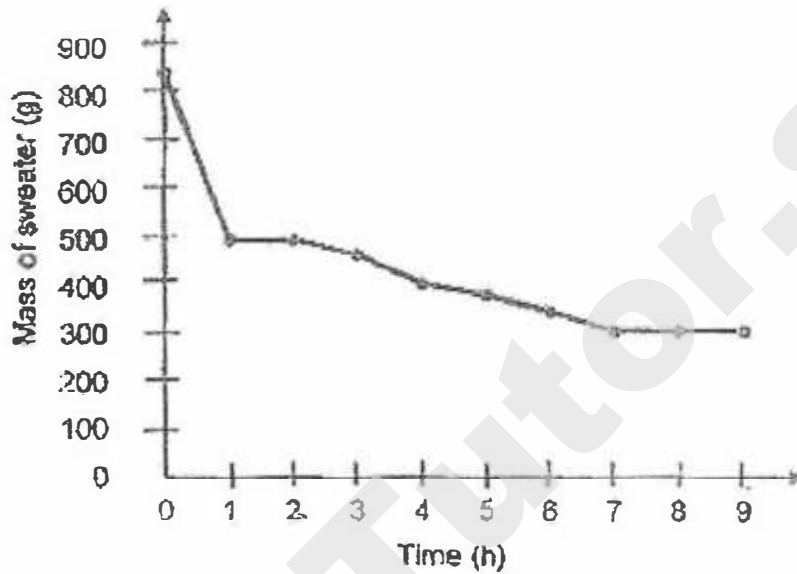

How long did the sweater take to dry completely?

[1]

- (d) The children repeated their test the next day. They washed and dried the sweater in the same way and in the same location. However, they noticed that the sweater dried more quickly.

Give one possible reason why the sweater dried more quickly when they repeated their test. [1]

(Go on to the next page)

SCORE	2
-------	---

39 Ray made a game in which he has to move a metal ring along a thick wire until it reaches the rest position. The metal ring is connected to the electrical circuit with a wire which is covered with a plastic handle.

When he is moving the metal ring, it must not touch the wire. If it touches the wire, a bulb will light.

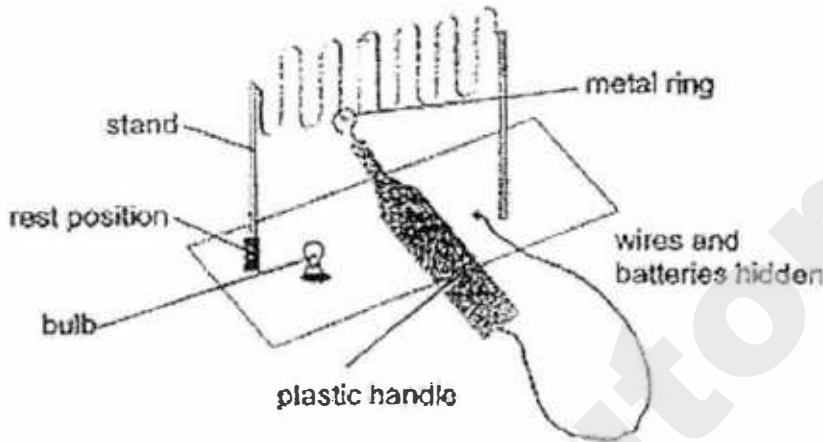

(a) In order to allow electricity to pass through, what property must the metal ring and thick wire have? [1]

(b) When the metal ring reaches the rest position, the bulb does not light up. Which of the following could Ray possibly use to cover the rest position? Tick (✓) the correct box(es).

Clear sticky tape	
Plasticine	
Steel wool	
Copper wire	
Cardboard	
Aluminium foil	

(Go on to the next page)

SCORE	
-------	--

Continue from question 39

- (c) The bulb will only work in Ray's game when the metal ring touches the wire.

Put a tick in the box to show the correct set-up for his game. [1]

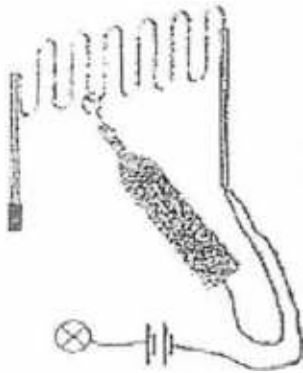

- (d) Ray plays the game and decides that he wants the bulb to be brighter. Without changing the bulb, how can he change the circuit to make the bulb brighter? [1]

(Go on to the next page)

SCORE	2
-------	---

- 40 Ben built a puzzle circuit with three identical bulbs and batteries. He covered the connections to the bulbs with a piece of card as shown below. The bulbs could be seen through holes in the card.

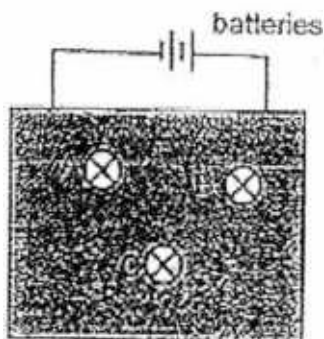

All the bulbs lighted up but their brightness was different.

Ben removed bulbs A, B and C in turn. Before connecting each bulb back into the circuit, he observed the other two bulbs.

He recorded his observations in the table below.

		Did the bulb light up?		
Removed	A	B	C	
A		No	Yes	
B	No		Yes	
C	Yes	Yes		

- (a) Complete the circuit in the diagram below to show how the three bulbs could be connected. [2]

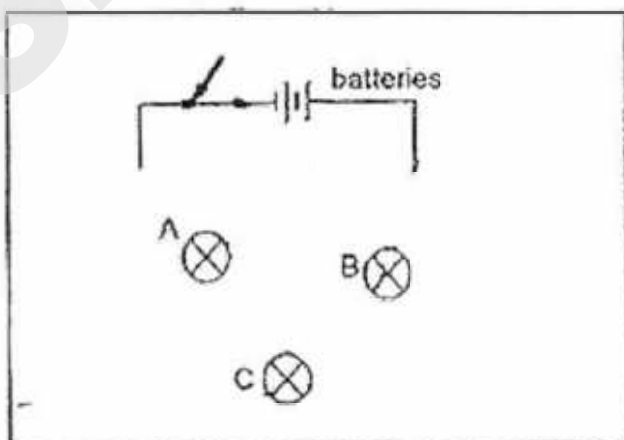

(Go on to the next page)

SCORE	2
-------	---

Continue from question 40

- (b) Ben added a switch to the circuit so that he could turn on all three bulbs on and off at the same time. [1]

Put a letter 'S' on your circuit diagram where the switch could be placed.

- (c) Ben used three similar bulbs but they were of different brightness. State one advantage and one disadvantage of bulbs arranged in parallel. [2]

Advantage : _____

Disadvantage : _____

(Go on to the next page)

SCORE	
-------	---

- 41 Daryl used three rods, X, Y and Z, and placed them one at a time in the electrical circuit as shown below. The rods are of similar size and thickness. The bulb lighted up when rods X and Z were used but did not light up when rod Y was used.

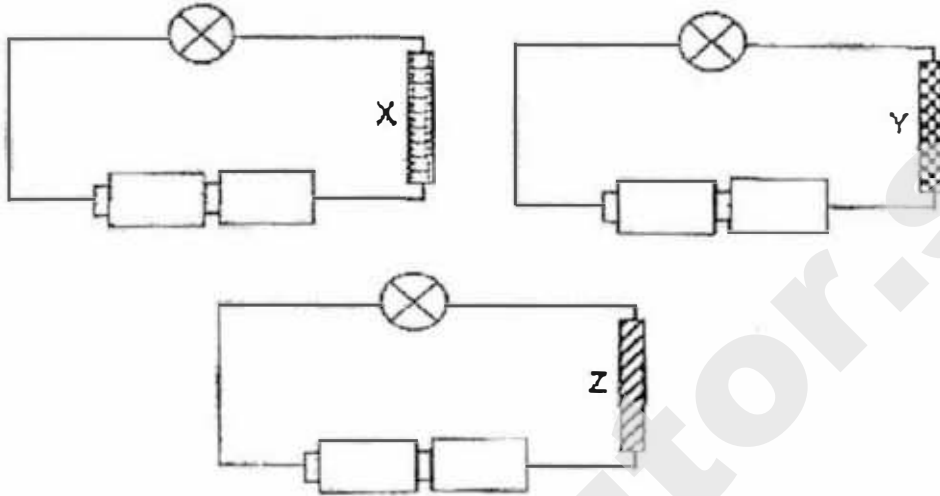

The rods were then used in another electrical circuit and placed at positions A, B and C.

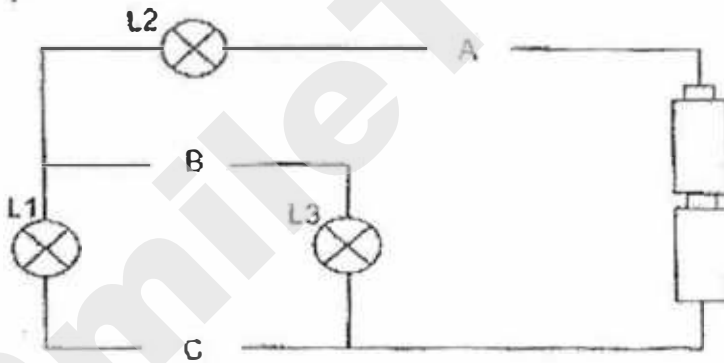

[3]

Based on the circuit above, complete the table below. Put a tick (✓) in the appropriate boxes to indicate if bulbs L1, L2 or L3 lights up.

	Position of rods			Bulb		
	A	B	C	L1	L2	L3
(i)	X		Z			
(ii)	Y	Z	X			
(iii)	Z	X	Y			

End of Booklet B

SCORE	3
-------	---

YEAR : 2017
 LEVEL : PRIMARY 5
 SCHOOL : CATHOLIC HIGH SCHOOL
 SUBJECT : SCIENCE
 TERM : SA1

Booklet A

Q1	Q2	Q3	Q4	Q5	Q6	Q7	Q8	Q9	Q10
2	2	1	3	3	4	2	1	2	1
Q11	Q12	Q13	Q14	Q15	Q16	Q17	Q18	Q19	Q20
2	1	4	1	3	4	3	3	4	4
Q21	Q22	Q23	Q24	Q25	Q26	Q27	Q28		
1	3	4	3	1	3	1	1		

Booklet B

Q29a Animal Q has four legs but does not swim.

Q29b Animal Q has four legs but animal R does not have four legs.

Q30a

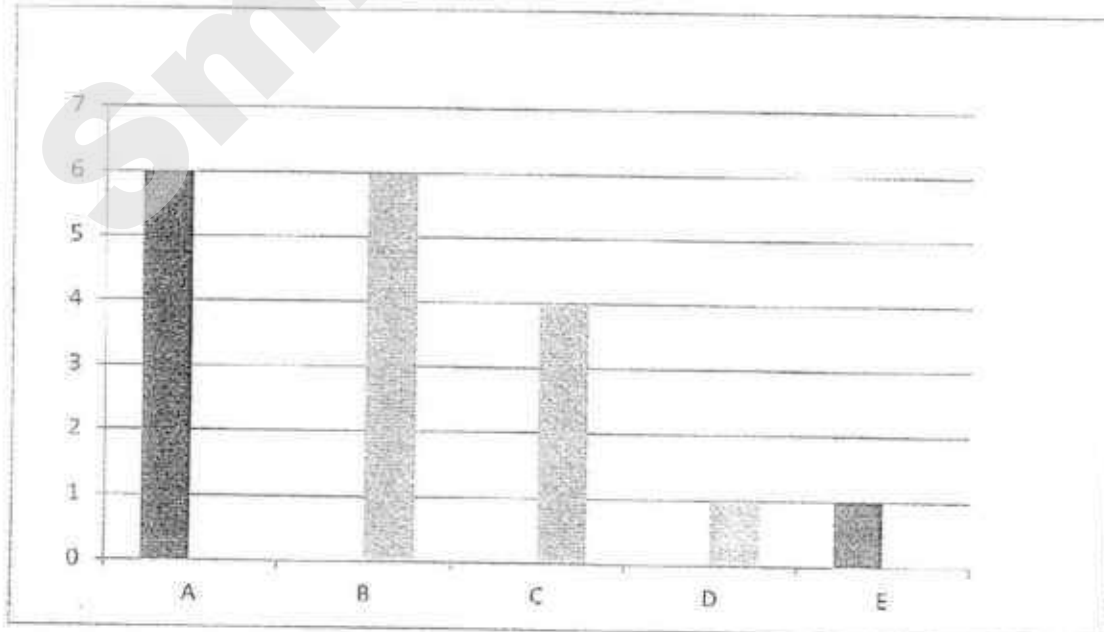

Q30b The digested food was being absorbed into the bloodstream of the intestinal walls.

Q31i The life cycle of a butterfly has 4 stages but the life cycle of a cockroach has 3 stages.

Q31ii The young of the cockroach resembles the adult but the young of the butterfly does not resemble the adult.



Q32



Explain: As the distance from the plant increases, the number of the young plants also increases. M was dispersed by wind because the wing like structure enable M to stay in the air for a longer period of time to be carried further away from the parent plant.

Q33a Rod D. the number of pins left on the tray was the least, so it attracted the most number of pins.

Q33b By decreasing the distance between the rod and the tray of pins.

Q33c Rod Q is not a magnetic material.

Q34a The volume of air would decrease but the volume of water would remain the same.

Q34b No. Air can only be compressed up to a certain limit as air occupies space.

Q35a To ensure that the light sensor only measures the light that passes through the material.

Q35b Material B. It allowed most light to pass through, thus when the sun shines onto the window, the passers-by can see what is inside the shop most clearly.

Q35c

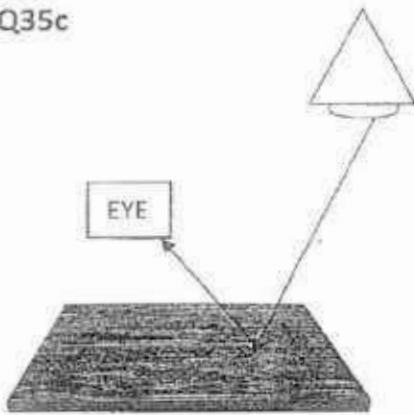

Q36ai Different materials expand at different rates.

Q36aii Less than 25 minutes as the rod was thinner thus less heat was required to expand.

Q36b On a hot day, the bridge would expand and increase in length. The gaps in the joints would allow the bridge to expand.

Q37a The water vapour in the warmer surrounding air came into contact with the cooler surface of the window, it then loses heat and condenses into water droplets.

Q37b When he switched off the air conditioner and wound down the windows, the warmer water vapour in the air could flow into the car and the temperature in the car would be 33°C . Temperature in the air would be the same as the temperature outside the car so no condensation would take place.

Q38a The sweater absorbed the water. So it was heavier as they were carrying the mass of both the sweater and the water.

Q38bi Evaporation

Q38ii Liquid to Gas

Q38c 7 hours

Q38d It was a windier day than the day before

Q39a Allow electricity to pass through

Q39b

Clear sticky tape	✓
Plasticine	✓
Steel wool	
Copper wire	
Cardboard	✓
Aluminium foil	

Q39c

<input type="checkbox"/>	<input checked="" type="checkbox"/>
<input type="checkbox"/>	<input type="checkbox"/>

Q39d

Add a battery

Q40a/b

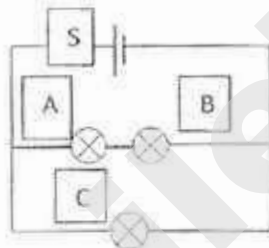

Q40c

Advantage: When one bulb fuses, the other bulbs remain lighted

Disadvantages: The batteries in the circuit do not last so long

Q41

L1	L2	L3
✓	✓	
	✓	✓

FIRST SEMESTRAL ASSESSMENT 2017

PRIMARY 5

SCIENCE

SECTION A (56 MARKS)

INSTRUCTIONS TO CANDIDATES

1. Do not turn over this page until you are told to do so.
2. Follow all instructions carefully.
3. Answer all questions.
4. Shade your answers on the Optical Answer Sheet (OAS) provided.

Name: _____ ()

Class: Primary 5 ()

Date: 12 May 2017

Total Time for Sections A and B: 1 h 45 min

Section	Marks
A	/ 56
B	/ 44
Total	/100

Parent's Signature: _____

Booklet A (66 marks)

For each question from 1 to 28, four options are given. One of them is the correct answer. Make your choice (1, 2, 3 or 4). Shade the correct oval (1, 2, 3 or 4) on the **Optical Answer Sheet**.

1. Tables A and B below show the characteristics of two dogs and their puppies.

Table A	Characteristics		
Dog	Short hair	Black spots	Long ears
Male	Yes	Yes	No
Female	No	Yes	No

Table B	Characteristics		
Puppy	Short hair	Black spots	Long ears
A	Yes	Yes	No
B	No	Yes	No
C	Yes	No	Yes
D	Yes	Yes	No

Which puppy is **least** likely to be an offspring of the male and female dog?

- (1) A
- (2) B
- (3) C
- (4) D

2. Study the family tree of Jane below. It shows who are the tongue rollers and the non-tongue rollers.

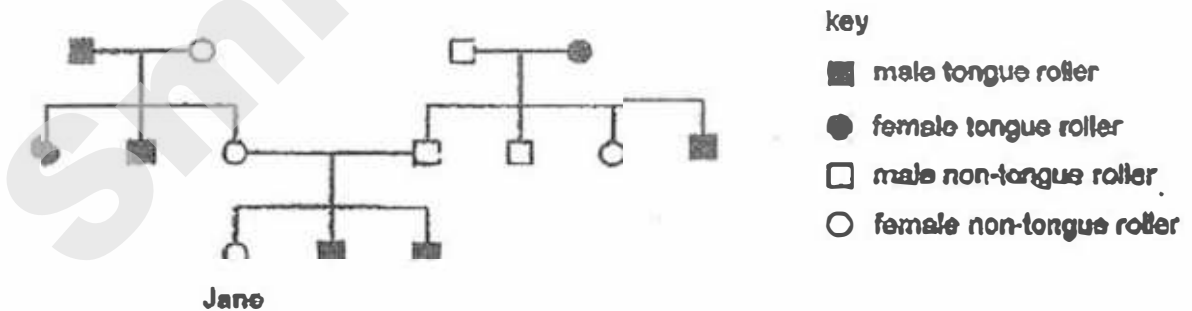

Which of the following statements about the family tree is correct?

- (1) Jane's mother is a tongue roller.
- (2) Jane has 2 sisters who are tongue rollers.
- (3) Both Jane's grandfathers are non-tongue rollers.
- (4) Jane's mother has a brother who is a tongue roller.



3. The diagram below shows a process in the human reproduction system.

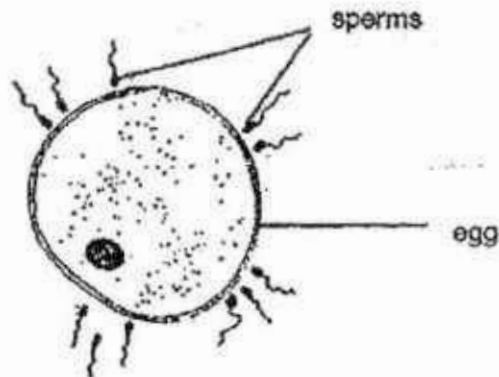

Which of the following statements are correct?

- A: The egg will develop in the womb after this process.
- B: This process takes place after pollination in humans.
- C: Flowering plants also go through a similar process to reproduce.
- D: The egg is produced in the ovaries of the female reproductive system.

- (1) A and C only
- (2) B and D only
- (3) A, B and D only
- (4) A, C and D only

4. The diagram below shows part of the human reproductive system.

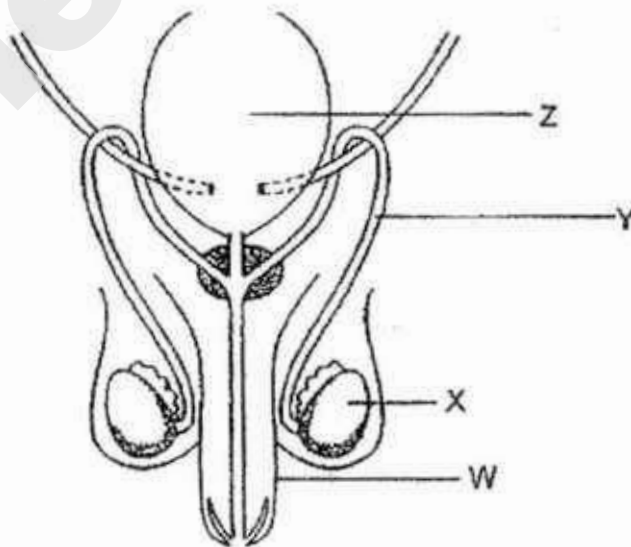

Which part produces the reproductive cells?

- (1) W
- (2) X
- (3) Y
- (4) Z



5. The diagram below shows the cross-section of a flower.

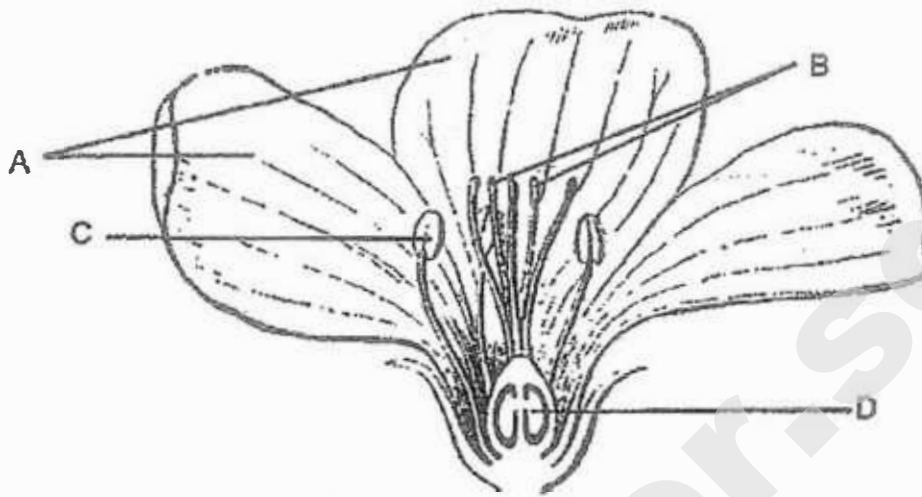

Jin Shin wanted to investigate if a flower will develop into a fruit if she cuts off different parts of the flower.

Which of the following is correct?

	Parts of flower cut off	Outcome
(1)	A only	Not possible to develop into a fruit
(2)	C only	Possible to develop into a fruit
(3)	B and D only	Possible to develop into a fruit
(4)	A, B and C only	Possible to develop into a fruit



6. The diagram below shows how plant Y disperses its seeds.



Which of the following graphs represent the distance of the young plant from the parent plant Y?

(1)

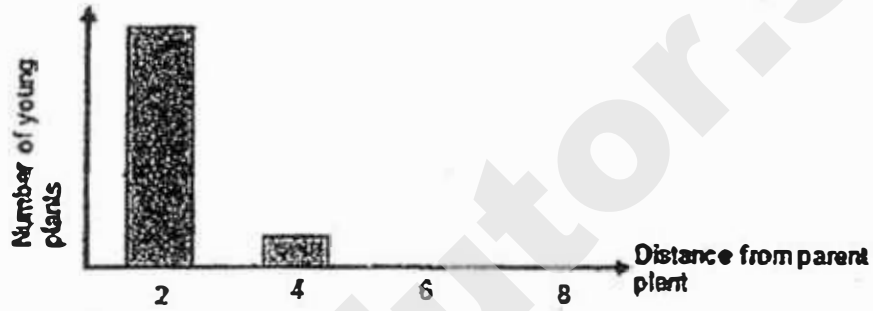

(2)

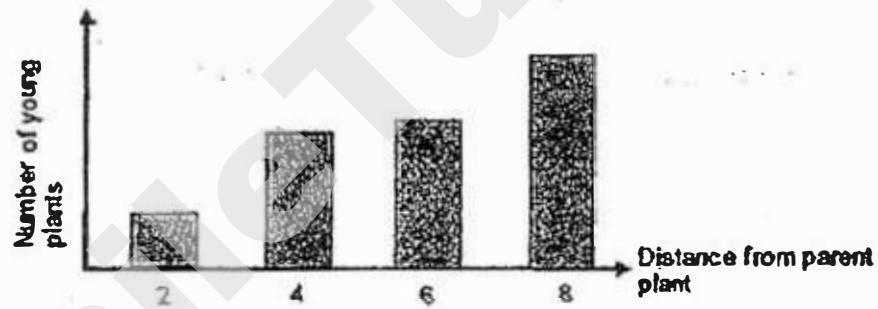

(3)

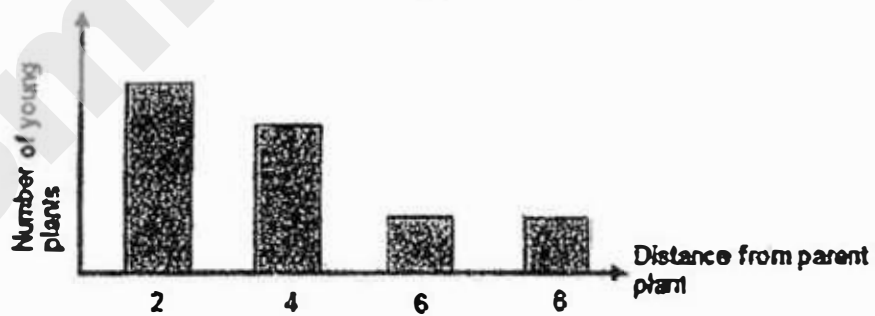

(4)

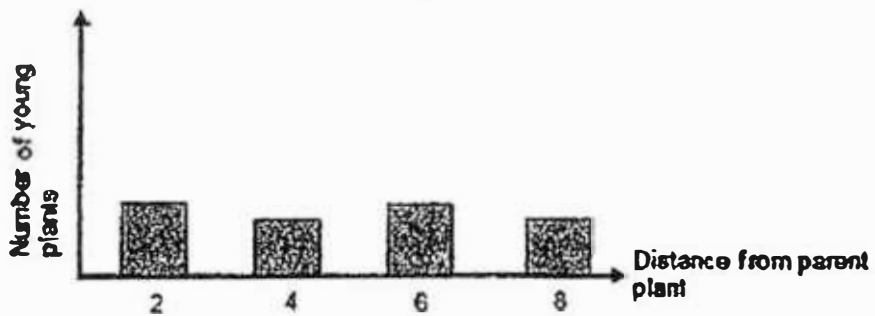

7. Shanhi sketched the dispersal pattern of a seed as shown below.

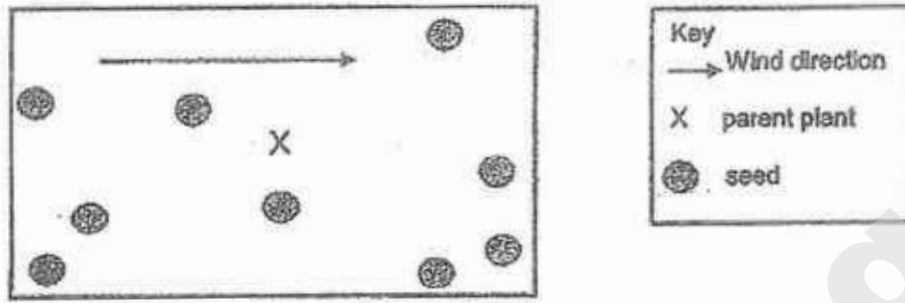

Which of the following is most likely the seed that has the dispersal pattern above?

(1)



(2)



(3)



(4)



8. Study the table on the male reproductive cells of the plant and the human.

Male reproductive cells		
	In Flowering Plants	In Humans
A:	produced in large numbers	produced in large numbers
B:	produced in the anther	produced in the testes
C:	fuses with the female reproductive cell in the stigma	fuses with the female reproductive cell in the ovary

Which of the following statement(s) is/are correct?

- (1) A only
 - (2) C only
 - (3) A and B only
 - (4) B and C only
9. The arrows in the diagram below shows how substance P moves in a germinating seed.

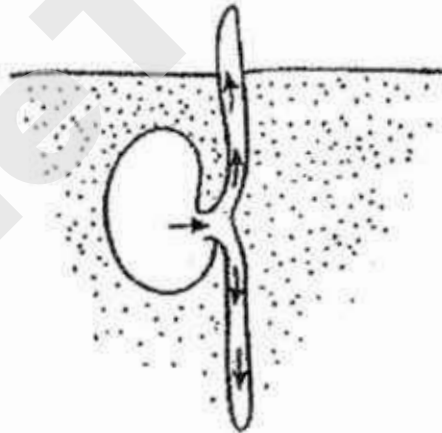

Which of the following represents substance P?

- (1) air
- (2) soil
- (3) food
- (4) water



10. Jane conducted an experiment to investigate how temperature of the surrounding air affects the time taken by seed A to germinate.

The graph below shows the results of her experiment.

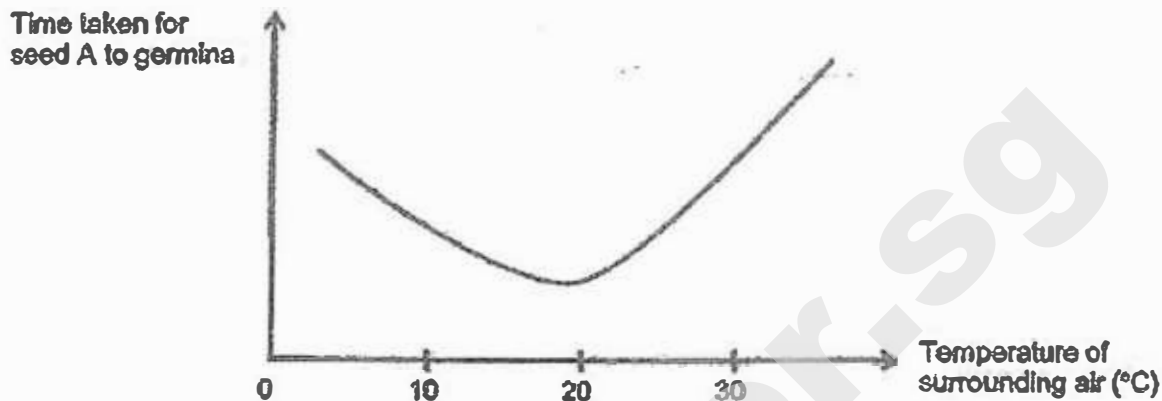

She then conducted another experiment to investigate how the amount of water will affect the time taken by seed A to germinate.

The graph below shows the results of her experiment.

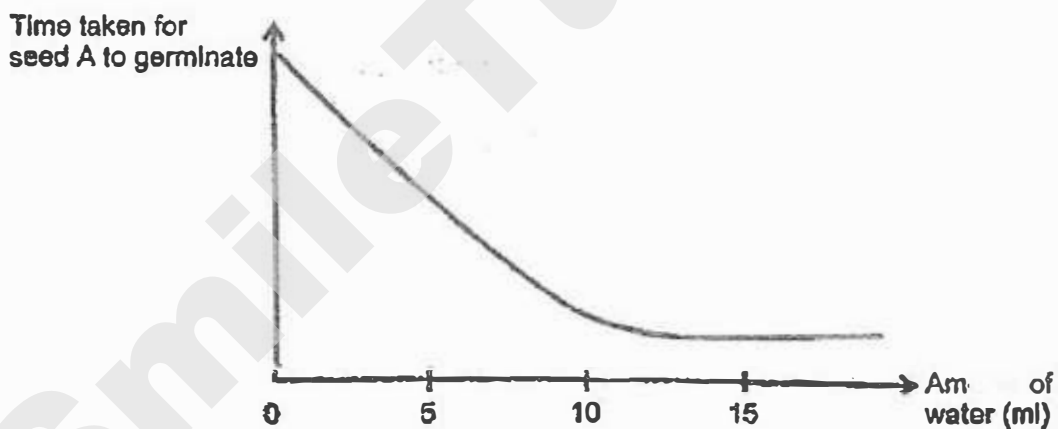

Based on the results of Jane's experiments, which of the following conditions will help seed A to germinate the fastest?

	Temperature of surrounding air (°C)	Amount of water (ml)
(1)	10	10
(2)	20	15
(3)	20	5
(4)	30	15



11. The diagram below shows a cell being observed under a microscope.

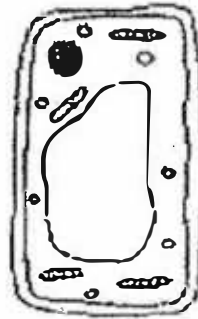

From which part of an organism could the above cell be taken from?

- (1) skin of an animal
 - (2) cheek of an animal
 - (3) leaf of a plant
 - (4) leg of an animal
12. A student placed two cells, P and Q, in solution Z. Solution Z was absorbed into both cells. Soon, Cell P swelled up and burst but Cell Q remained the same.

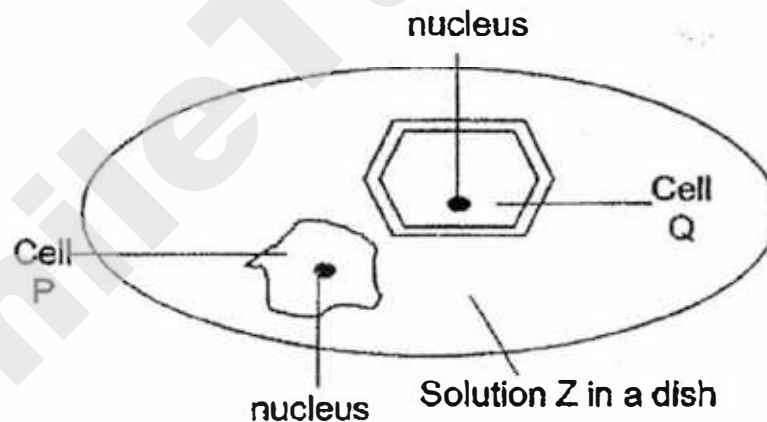

What is a possible reason why Cell Q did not swell up like Cell P?

- (1) Cell P has a nucleus which controls the movement of solution Z in the cell.
- (2) Cell P has a cell membrane that prevents solution Z from entering.
- (3) Cell Q has a cell wall that keeps its shape and prevents the cell from swelling up.
- (4) Cell Q has a chloroplast that prevents solution Z from entering the cell.



13. The diagram below shows animals, P and Q.

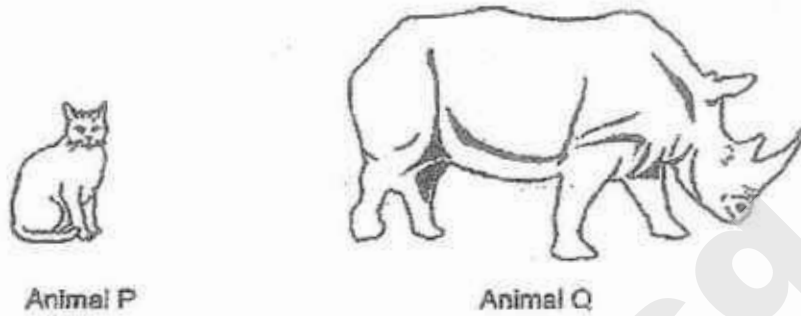

Which of the following about the cells found in these two animals are correct?

- A: Animal Q has more cells than Animal P.
- B: Both of them have more than one type of cell.
- C: The cells of animal P have no cell wall.
- D: The cells found in the animal Q have cell wall.

- (1) A and B only
- (2) B and C only
- (3) A, B and C only
- (4) B, C and D only

14. In an experiment, the volume of a marble was measured as shown in the diagram below.

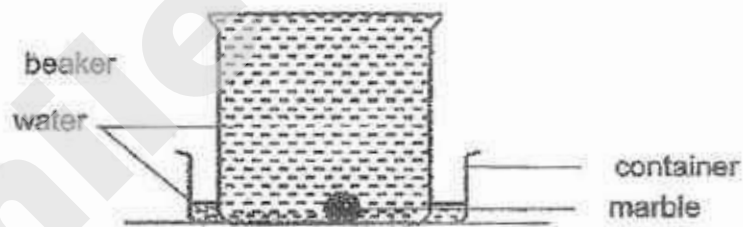

Which one of the following would give the volume of the marble?

- (1) Measure the amount of water left in the beaker.
- (2) Measure the amount of water collected in the container.
- (3) Measure the amount of water needed to fill up the beaker.
- (4) Measure the amount of water needed to refill the container.



15. Max observed the water cycle diagram shown below.

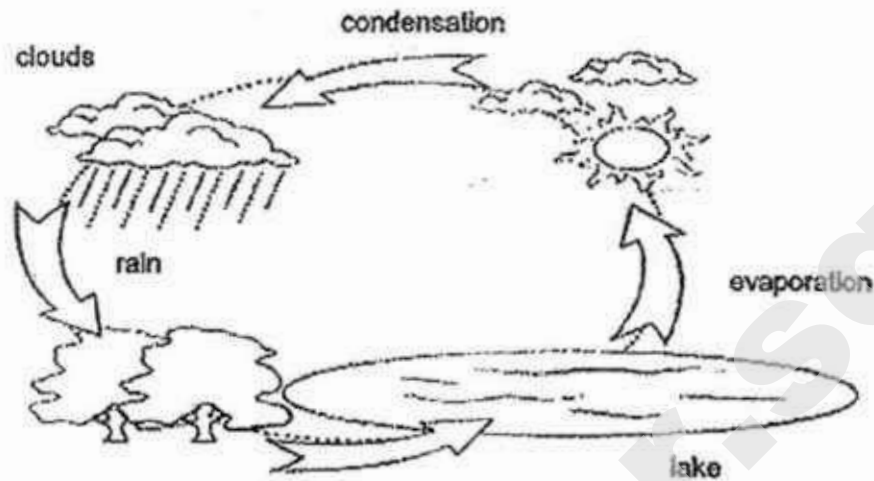

Max asked his classmates what is likely to happen when the surrounding temperature of the lake increases.

Which of the following statements by Max's classmates is **not** correct?

- (1) The rate of evaporation of water in the lake will decrease.
 - (2) The rate of evaporation of water in the lake will increase.
 - (3) The water cycle will be affected by the changes in surrounding temperature of the lake.
 - (4) Water from the lake will still evaporate and condense to form the clouds.
16. The diagram below shows the changes in the states of water.

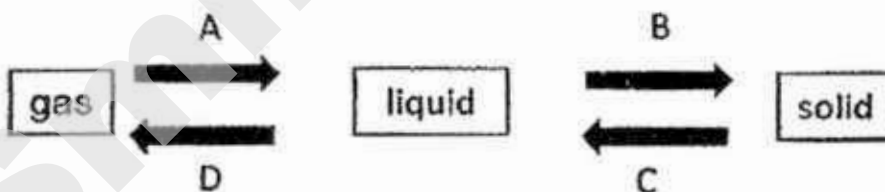

Which one of the following correctly describes the heat transfer involved in processes A, B, C and D?

	Heat gain	Heat loss
(1)	A and C	B and D
(2)	C and D	A and B
(3)	B and C	A and D
(4)	B and D	A and C



17. A student wanted to study the factors that affect the rate of evaporation of water. He used two of the set-ups as shown in the table below to conduct some investigations.

Set-up	Material of container	Exposed surface area (cm ²)	Original amount of water (ml)	Temperature of water at the start (°C)
P	plastic	200	500	50
Q	glass	200	250	50
R	plastic	400	500	50
S	glass	200	250	70

Which are the possible aims of his investigation?

- A: To find out if the material of container affects the rate of evaporation.
 B: To find out if the exposed surface area of water affects the rate of evaporation.
 C: To find out if the temperature of the water affects the rate of evaporation.

- (1) A and B only
 (2) A and C only
 (3) B and C only
 (4) A, B and C

18. A student poured 500 ml of water into two identical containers, P and Q and left them outdoors. 6 hours later, he found that there was less water left in container P than container Q as show below.



Container P



Container Q

Which of the following could explain the difference in the water level?

- A: Container P was left at a place with more sunlight.
 B: Container P was left at a brighter place.
 C: Container P was left at a place with lower temperature.
 D: Container P was filled with water at a higher temperature.

- (1) A and C only
 (2) B and D only
 (3) A and D only
 (4) B, C and D only



19. A student carried out an experiment using set-up P and set-up Q as shown. After 5 hours, the student compared the amount of water in each glass.

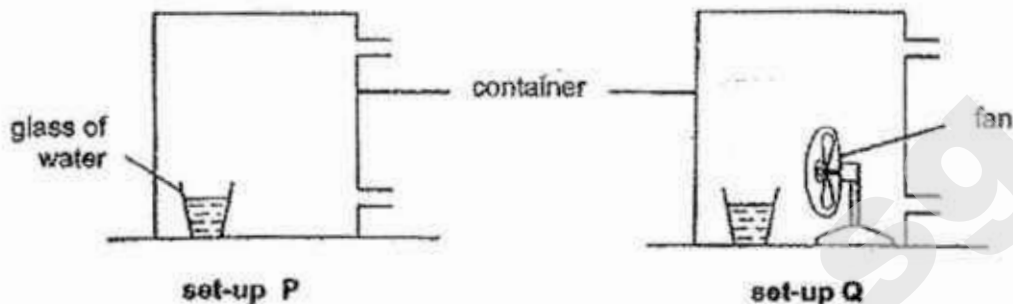

The amount of water left in the glass in set-up Q is _____.

- (1) less because the water evaporates faster
 - (2) less because the water evaporates slower
 - (3) more because the water evaporates faster
 - (4) more because the water evaporates slower
20. A student set up four experiments A, B, C and D using water in containers made of the same material.
The table below shows the different conditions at the start of each experiment.

	Experiment			
	A	B	C	D
Room temperature ($^{\circ}\text{C}$)	30	25	25	25
Exposed surface area of water (cm^2)	40	125	40	40
Volume of water (cm^3)	400	400	300	400

The student wanted to investigate how the rate of evaporation of water was affected by the exposed surface area.

Which of the following two experiments should the student compare?

- (1) A and B
- (2) A and C
- (3) B and D
- (4) A and D



21. The graph below shows the change in the surrounding temperature in a certain place over a period of time.

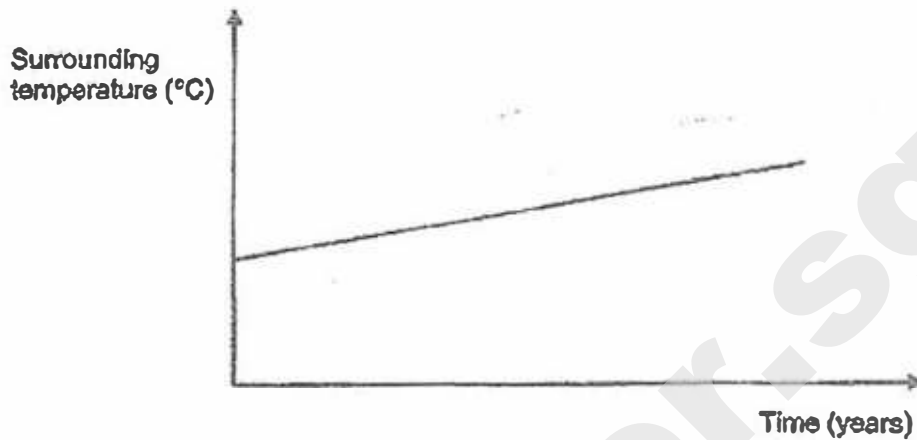

Which of the following activities contributed to the change in temperature over a period of time as shown in the graph?

- A: There is an increase in the number of cars on the road.
- B: People are recycling their waste products.
- C: More trees are cut down for housing.
- D: Land is burnt before new crops are cultivated.

- (1) A only
- (2) B only
- (3) A, C and D only
- (4) A, B, C and D

22. Deforestation is considered one major factor contributing to global climate change.

Which of the following are the impacts caused by deforestation?

- A: More carbon dioxide is released into the atmosphere.
- B: Plants and animals lose their habitat.
- C: Soil erosion helps in plant growth.

- (1) A only
- (2) A and B only
- (3) B and C only
- (4) A, B and C



23. Look at the graph shown below.

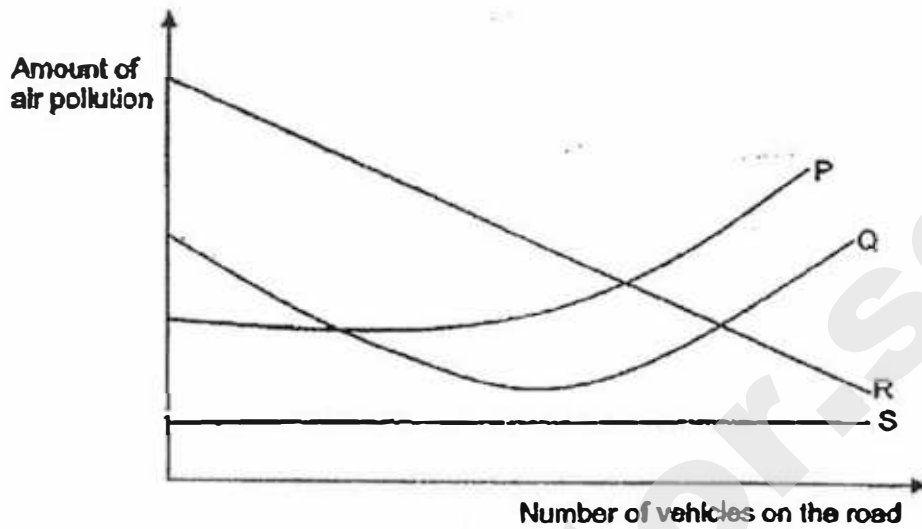

Which line, P, Q, R or S, on the graph below shows the result of an increased number of vehicles on the road?

- (1) P
 (2) Q
 (3) R
 (4) S
24. An experiment was set up using a sealed metal container which contains 80 cm^3 of water and 60 cm^3 of air as shown below.

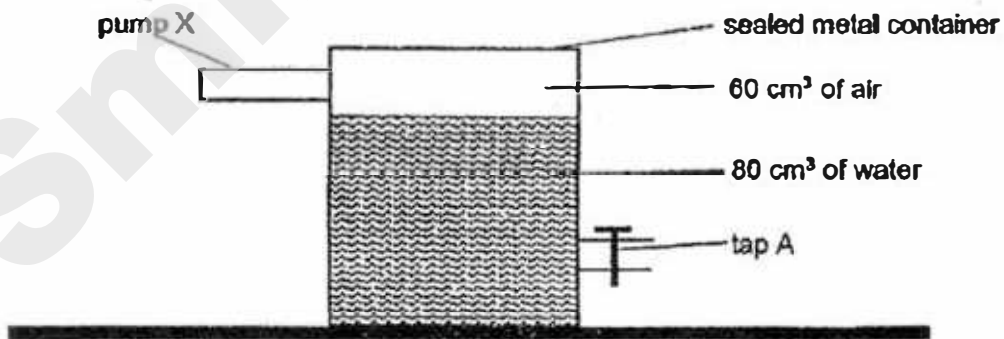

20 cm^3 of water was removed from the container through tap A and 40 cm^3 of air was then pumped in using pump X.

What would the final volume of the air in the container?

- (1) 20 cm^3
 (2) 40 cm^3
 (3) 60 cm^3
 (4) 80 cm^3



25. John placed two similar 5 kg metal blocks on two similar stools of different materials. Within a few minutes, he observed that stool P broke as shown in the diagram below.

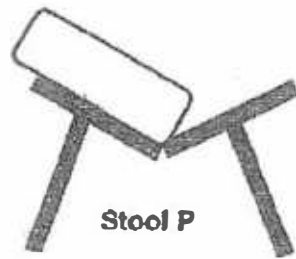

After that, he placed two similar 8 kg metal blocks on stool Q and another similar stool, R, made of a different material. Within a few minutes, he observed that stool Q broke as shown in the diagram below.

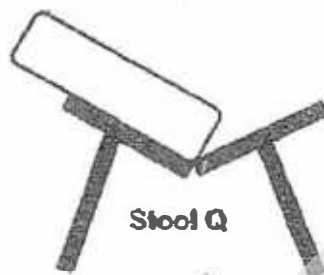

What conclusion(s) can John make based on his observations?

- A: Stool P is made of the weakest material.
- B: Stool Q is made of a stronger material than stool P.
- C: Stool Q is made of a stronger material than stool R.
- D: Stool R is made of the strongest material.

- (1) A only
- (2) A and B only
- (3) A, B and D only
- (4) B, C and D only



26. The following set-ups A and B below were placed in the Science Room with a room temperature of about 29°C.

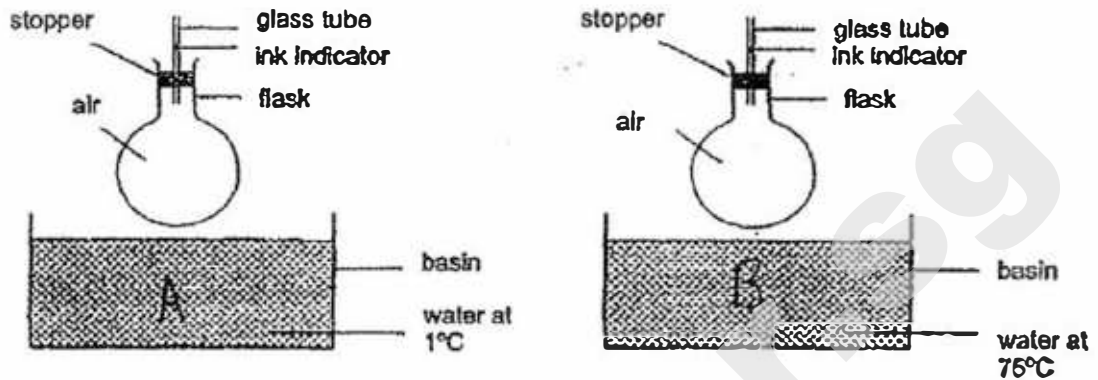

Which of the following could be observed 2 minutes after the flask was placed in the basin in set-ups A and B?

	Observations for A	Observations for B
(1)	The ink indicator will fall	The ink indicator will rise
(2)	The ink indicator will rise	The ink indicator will fall
(3)	The water level in the basin will fall	The water level in the basin will rise
(4)	The water level in the basin will rise	The water level in the basin will fall

27. The diagram below shows four similar magnets with their poles labelled and arranged in the following way.

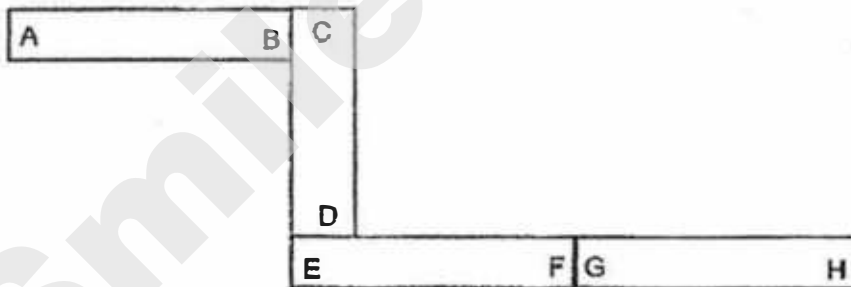

Which of the following shows a possible arrangement of the magnets?

- (1)

A	B	D	C
---	---	---	---
- (2)

C	D	H	G
---	---	---	---
- (3)

E	F	B	A
---	---	---	---
- (4)

G	H	E	F
---	---	---	---



28. The diagram below shows the life cycle of an animal.

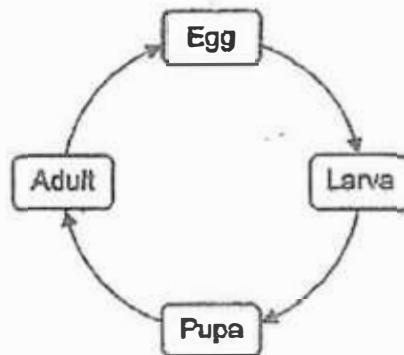

Which group(s) of the following animals has / have same life cycle as the animal shown above?

Group X	Group Y	Group Z
chicken	mosquito	frog
cockroach	butterfly	mealworm beetle

- (1) Group Y
- (2) Group Z
- (3) Groups X and Y
- (4) Groups Y and Z

End of Booklet A



FIRST SEMESTRAL ASSESSMENT 2017

PRIMARY 5

SCIENCE

SECTION B (44 MARKS)

INSTRUCTIONS TO CANDIDATES

1. Do not turn over this page until you are told to do so.
2. Follow all instructions carefully.
3. Answer all questions.

Name: _____ ()

Class: Primary 5 ()

Date: 12 May 2017

Total Time for Sections A and B: 1 h 45 min

Marks for Section B: _____

Booklet B (44 marks)

Write your answers to questions 29 to 40 in the spaces given.

29. The diagram below shows the female reproductive system.

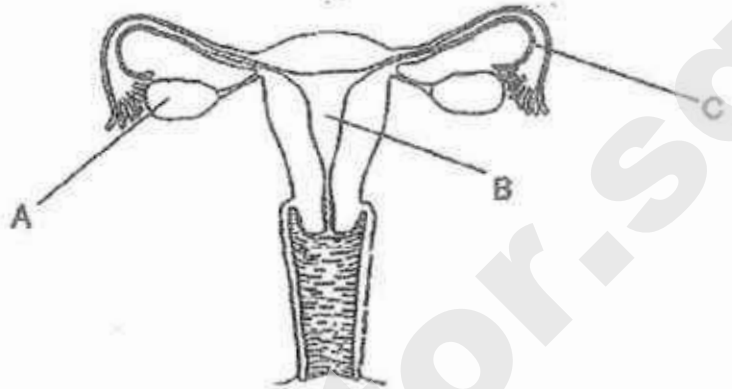

a) State the part (A, B or C) where the foetus develop and grows after fertilisation. [1]

b) Fertilisation cannot take place if part A stops functioning. Explain why. [1]

SmileTutor.sg



30. The diagram below shows processes A, B, C and D in the life cycle of a flowering plant.

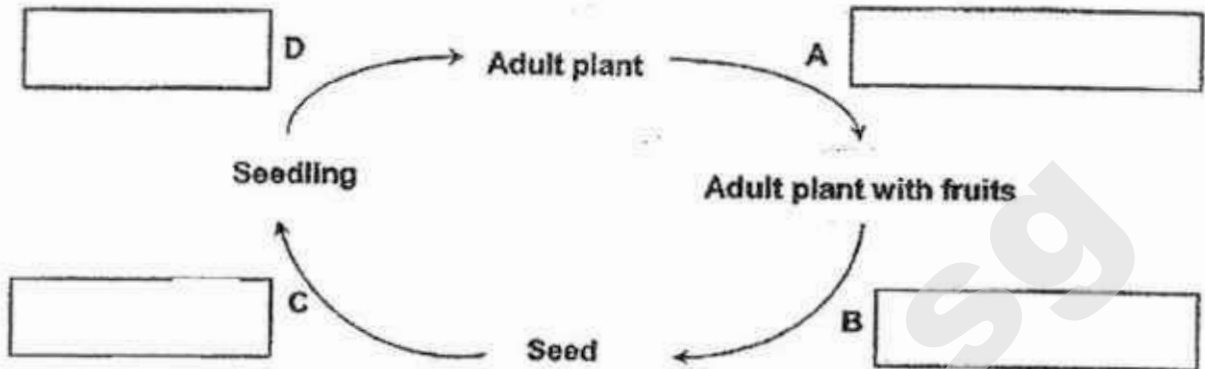

a) Write the helping words given below into the correct boxes shown above. [2]

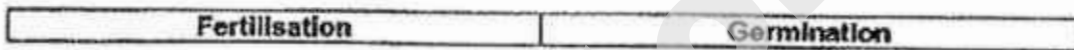

The diagram below shows two flowers and their respective parts.

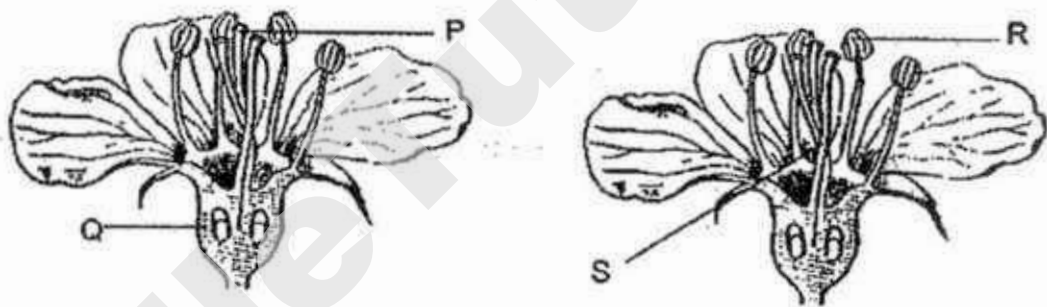

b) Fill in the boxes below with P, Q, R and/or S to show the movement of pollen grains for pollination to be successful. [1]

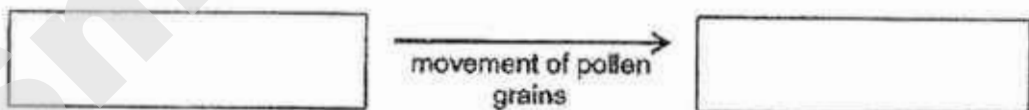

c) In which part, P, Q, R or S, are ovules found? [1]



31. The table below gives some information about plants P, Q and R.

Characteristics	Plants		
	P	Q	R
presence of ovules	✓		✓
dispersed by water	✓	✓	
dispersed by splitting			✓

a) Explain why plant P cannot be a fern. [1]

b) Based on the information given in the table above, state two characteristics of the seeds for plant Q. [2]

(i) _____

(ii) _____

Sam counted and recorded the number of young plants that were found a certain distance from the parent plants Q and R in the table below.

Data set	Distance from parent plant				
	1m	2m	3m	4m	5m
1	5	7	6	4	3
2	7	1	0	0	0

c) Which young plant, Q or R does data set 2 represent? [1]

d) Explain why it is better for the seeds to be dispersed further away from the parent plant. [1]



32. The diagram below shows a plant cell.

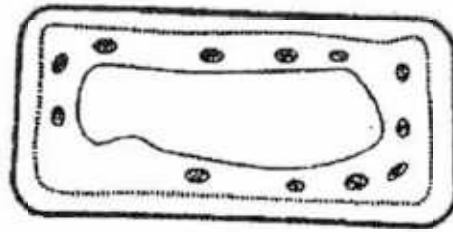

plant cell

- a) One part is missing in the cell. The missing part helps to control activities that take place in the cell. Name the missing part. [1]

- b) Name one part of the above cell that is not found in an animal cell. [1]

A student found a one-celled organism taken from the school pond shown in the diagram below.

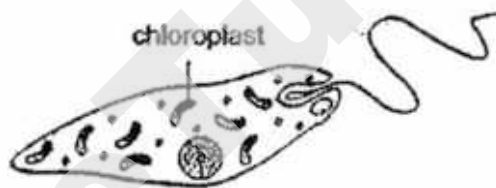

- c) The student observes that the organism needs to move towards light for survival. Explain why. [2]



33. Study the diagram of water cycle below.

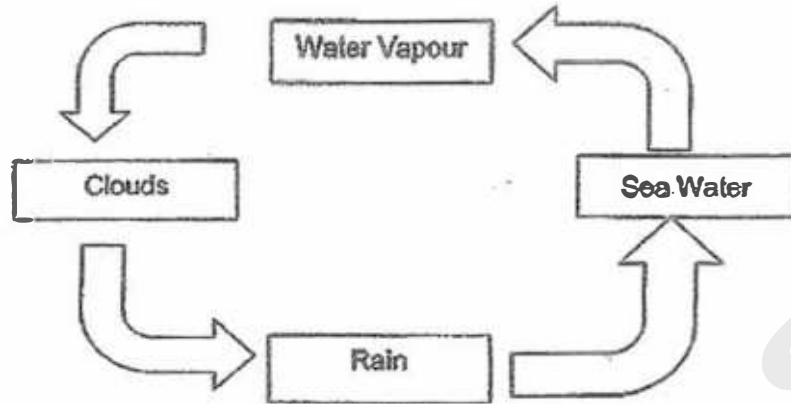

a) Explain the importance of water cycle to living things.

[1]

The diagram below shows a model of a water cycle set up by a student to demonstrate the formation of rain. The student noticed that there were only a few water droplets formed on the underside of the aluminium sheet.

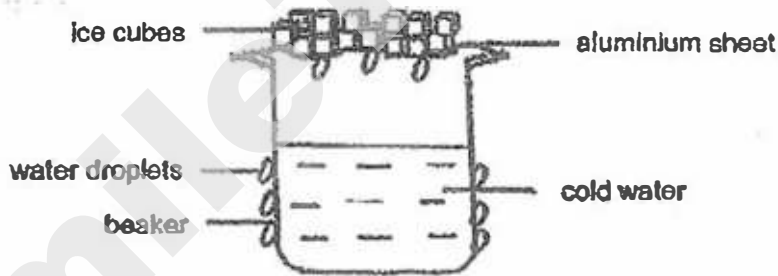

b) The student noticed that there were water droplets forming on the outer surface of the beaker. Explain how these water droplets were formed.

[2]

c) Suggest what the student could do to the set-up so that more water droplets are formed on the underside of the aluminium sheet. Give a reason for your answer.

[2]



34. A group of students went camping at a beach and was tasked to obtain drinking water from the sea. They dug a hole in the ground and lined it with a plastic sheet. They collected some sea water and poured it into the hole.

An empty cup was placed in the middle and another plastic sheet was used to cover the hole. They also placed rocks at the two sides and a pebble was placed as shown in the diagram below.

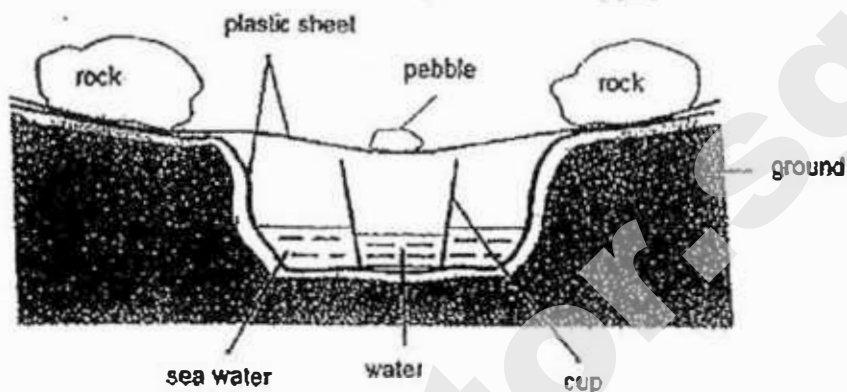

- a) How will the water collected in the cup taste? Give a reason for your answer. [2]

- b) What difference would the students observe in the cup if the pebble on the plastic sheet in (a) was replaced with cold water? [1]

Another group of students did a similar task with the same amount of sea water in the hole. Instead of using a cup, they used a large bowl to collect the water.

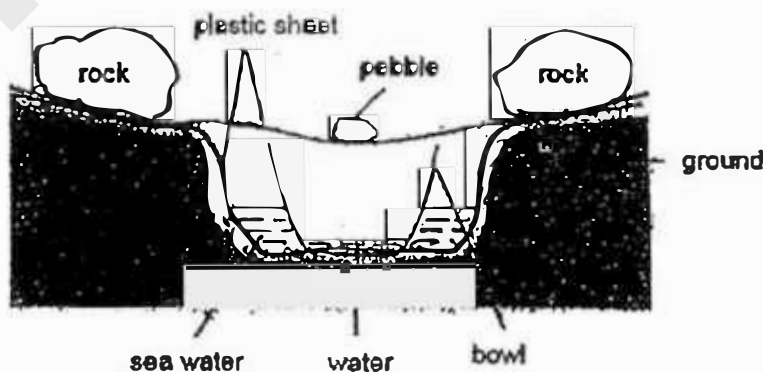

- c) After another 6 hours, they found that less water was collected in the bowl. Explain what had happened. [2]



35. Ms Lee carried out an experiment to find out the effect of plants on soil erosion. She set up two identical set-ups as shown below. Set-up A does not have plants growing in the soil while set-up B has grass growing in the soil. An equal amount of water was poured into each tray. Water was collected in the two beakers below the trays.

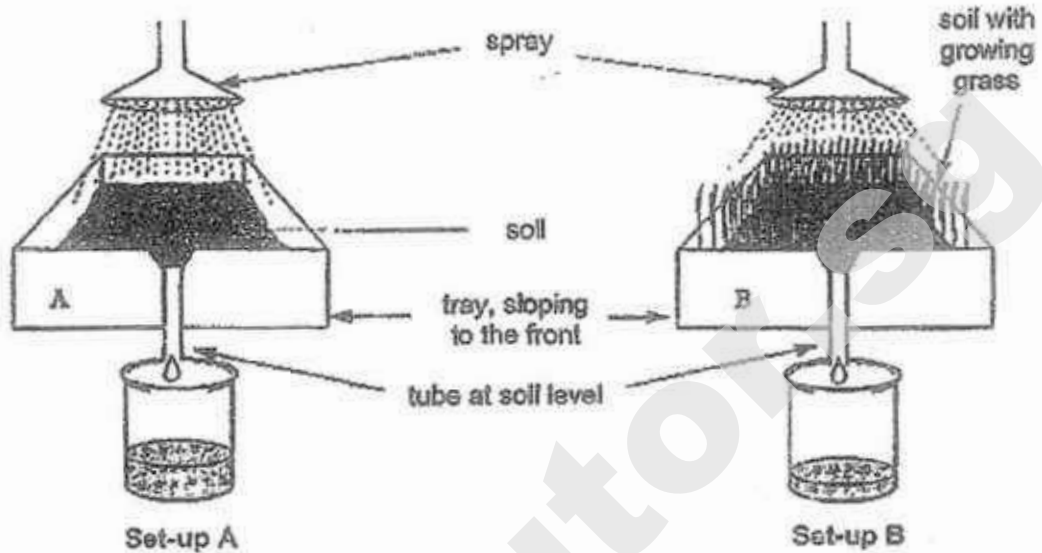

Which beaker will have more soil at the end of the experiment?
Give a reason for your answer.

[2]

36. Hashim placed three different substances into three identical containers as shown below.



- a) Which substance is most likely to be a solid? Explain why.

[2]

- b) If Hashim wants to prove that substance A is a liquid, what should he do? Give a reason for your answer.

[2]

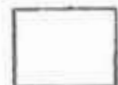

37. Samy set up the experiment as shown below.

The two set-ups are identical except container A holding the water in Set-up X and container B holding the water in Set-up Y were made of different materials. The water in the containers were heated to 100°C.

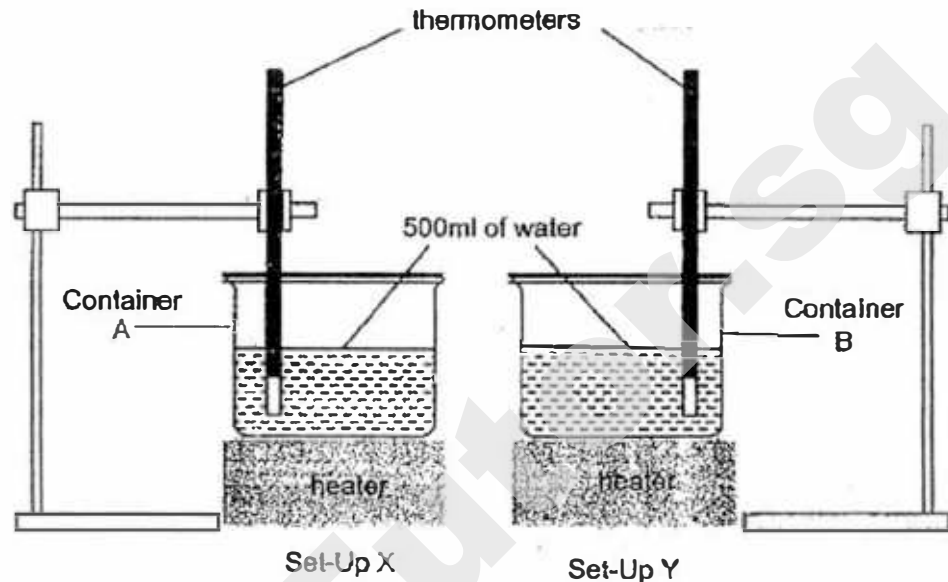

He recorded the results of the experiment in the table shown below.

	Time taken for the water to reach 100°C (s)
Set-up X	80
Set-up Y	35

a) Based on the results, complete the table below stating the material, metal or glass, each container is made of in the above set-ups.

Container	Material of the container
A	
B	

[1]

b) Explain your reason of choice for the material you chose for Container A and Container B.

[2]

c) The heater was switched off after the water in both containers reached 100°C. The water was left in the containers for 5 minutes. In which set-up, X or Y, would the water be cooler?

[1]



38. Tracy conducted several tests on materials A, B, C and D. She recorded her results in the table shown below.

Property	Materials			
	A	B	C	D
flexible	X	✓	X	✓
sinks in water	✓	✓	X	✓
waterproof	✓	X	✓	✓
allows most light to pass through	✓	X	X	✓

A tick (✓) indicates the presence of the property while a cross (X) indicates the absence of the property.

- a) Which material should be used to make a float for beginning swimmers? Give a reason for your answer. [2]

- b) Jenny concluded that both material B and C do not allow any light to pass through. Explain why Jenny could be wrong. [1]

39. Samy has two rods labelled X and Y and a bar magnet.



- a) He carried out an experiment using the rods and bar magnet. From his experiment, he concluded that rod X is a magnet.

Explain what he did and the observations he made to come to the conclusion that Rod X is a magnet. [2]

- b) Rod Y was attracted to the bar magnet as shown in the diagram below.



Can this observation be used to conclude that rod Y is a magnet? Explain why. [2]



40. An experiment was conducted to find out if water is needed for the germination of seeds.
Seeds were placed in each of the two identical test tubes as shown in the diagram.
The test tubes were placed near a window.

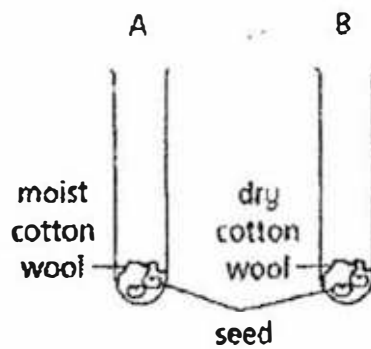

State two variables that must be kept the same in order for the experiment to be fair.

[2]

i)

ii)

End of Booklet B



Q	Answer	CORRECTIONS
29.	a) B b) Egg cells will not be produced	
30.	A: Fertilisation ; C: Germination a) R to P b) Q	
31.	a) Ovules are not found in Ferns b) Fibrous husk or able to float / waterproof / light / small / disperse by water / not disperse by splitting c) Plant R d) The young plants will not compete / fight with the parent plants for sunlight / water / nutrients / space	
32.	a) nucleus b) cell wall / chloroplasts c) It needs to absorb light to make food.	
33.	a) Water cycle ensures continued supply of (fresh) water for living things to survive b) Water vapour in the surrounding air touched the cool surface of the beaker, lost heat and condensed. c) Add more ice / salt to ice	
34.	a) The water would be tasteless; only the water evaporated b) More water is observed c) The exposed surface area of (sea) water is smaller so rate of evaporation is slower	
35.	Beaker A. There are no plant roots to hold the soil together	
36.	a) Substance C. It has a definite shape / it is stuck to the top of the container.	

	<p>b) Pour Substance A into different containers and see if substance A takes the shape of the containers.</p>	
37.	<p>a) A: Glass, B: Metal</p> <p>b) It takes a longer time for water in Container A to reach 100°C. Container A is conducted heat slower from the hot plate to the water.</p> <p>c) Set-Up Y / Y</p>	
38.	<p>a) C. It does not sink in water OR it is waterproof.</p> <p>b) Both B and C / B or C could be a translucent material.</p>	
39.	<p>a) He brought both ends of rod X to a/the pole of the magnet. One of the ends repelled the pole / magnet</p> <p>b) No, as rod Y could be made of a magnetic material and is only attracted to the magnet.</p>	
40.	<p>Any 2 of the following: number of seeds / type of seeds / mass of seeds / size of seeds / shape of seeds</p>	

Booklet A

1.	3	11.	3	21.	3
2.	4	12.	3	22.	2
3.	4	13.	3	23.	1
4.	2	14.	2	24.	4
5.	2	15.	1	25.	3
6.	2	16.	2	26.	1
7.	1	17.	3	27.	4
8.	3	18.	3	28.	1
9.	3	19.	1		
10.	2	20.	3		

2017 SEMESTRAL ASSESSMENT 1
PRIMARY 5 SCIENCE
(BOOKLET A)

Name : _____ ()

Class : Primary 5 _____

Date : 9 May 2017

Total Duration for Booklets A and B : 1 h 45 min

INSTRUCTIONS TO CANDIDATES:

1. Do not turn over this page until you are told to do so.
2. Follow all instructions carefully.
3. Answer all questions.
4. Shade your answers in the Optical Mark Sheet (OMS) provided.

This booklet consists of 17 printed pages.

BOOKLET A : [28 x 2 marks = 56 marks]

For each question from 1 to 28, four options are given. One of them is the correct answer. Make your choice (1, 2, 3 or 4). Shade your answer on the Optical Answer Sheet

1. Which of the following are not examples of water in the gaseous state?

- A. ice
- B. snow
- C. steam
- D. water vapour

- (1) B only
- (2) A and B only
- (3) C and D only
- (4) A, C and D only

2. Three containers of seeds A, B and C are planted under different conditions as shown below.

Container	Conditions			
	Air	Light	Water	Temperature
A	✓	x	✓	27°C
B	✓	✓	✓	-3°C
C	x	✓	✓	30°C

In which container(s) would the seeds germinate?

- (1) A only
- (2) B only
- (3) A and C only
- (4) B and C only

3. The diagrams below show a flower and a male human reproductive system.

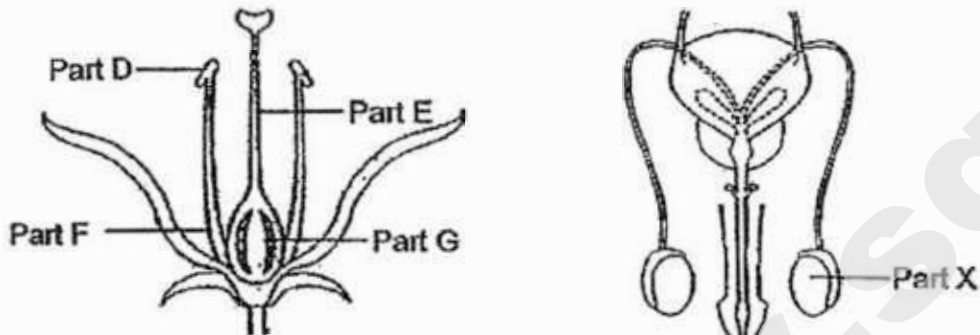

Which part of the flower has the same function as part X of the male human reproductive system?

- (1) Part D
 - (2) Part E
 - (3) Part F
 - (4) Part G
4. Four pupils observed Cell A as shown in the diagram below.

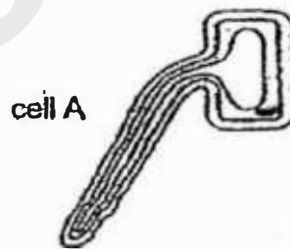

After observing cell A, each pupil made the following statement.

- Ali: This is an animal cell.
- Brandon: The cell wall gives the cell its shape.
- Chloe: The cell is able to control what goes into and out of it.
- Dennis: The cell is able to make its own food because it is a plant cell.

Which of the pupils were correct?

- (1) Ali and Brandon
- (2) Ali and Dennis
- (3) Brandon and Chloe
- (4) Chloe and Dennis

5. A white rose plant is placed inside a container filled with water that has been mixed with blue dye.

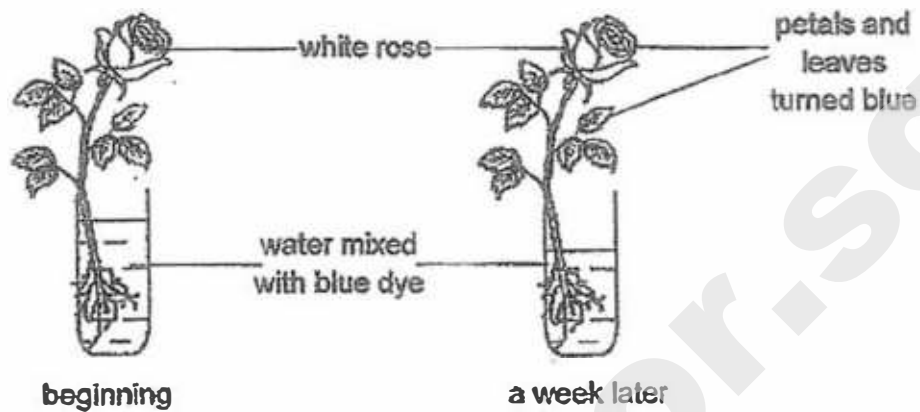

Which of the following can be concluded from the experiment?

- (1) The plant needs water to survive.
 - (2) Food-carrying tubes are present in the plant.
 - (3) The plant can trap sunlight to make food through photosynthesis.
 - (4) The coloured water has been transported to the flower and leaves.
6. Which of the following is an example of a matter?
- (1) light
 - (2) sound
 - (3) shadow
 - (4) skin cell
7. Which animal has a young that looks like its adult?
- (1) frog
 - (2) beetle
 - (3) butterfly
 - (4) cockroach
8. Which of the following shows the parts that belong to the same organ system?
- (1) mouth, gullet, lungs
 - (2) heart, lungs, blood vessels
 - (3) skull, ribcage, thigh muscles
 - (4) gullet, stomach, large intestines

9. A plant, as shown below, is placed under the sun and given plenty of water and nutrients.

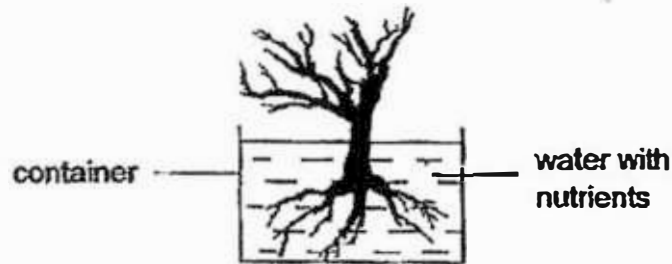

Which of the following best explains why the plant will die?

- (1) The plant cannot make food.
 - (2) The plant is not planted in soil.
 - (3) The plant has too much nutrients.
 - (4) The plant cannot anchor itself upright.
10. David classified the following into two groups based on whether they are light sources or non-light sources.

- sun
- moon
- mirror
- whiteboard
- lighted torch

Which of the following classification is shown correctly?

	Light sources	Non-light sources
(1)	sun, lighted torch	moon, whiteboard, mirror
(2)	sun, lighted torch, mirror	moon and whiteboard
(3)	sun, moon and lighted torch	whiteboard and mirror
(4)	moon, whiteboard, mirror	sun, lighted torch

11. The diagram below shows two metal blocks at different temperatures.



The metal blocks were then brought into contact with each other.

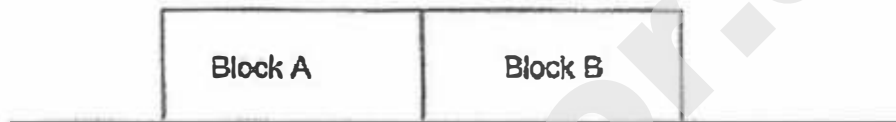

Which of the following shows the possible temperatures of the metal blocks after a few minutes?

	Block A (°C)	Block B (°C)
(1)	100	100
(2)	120	120
(3)	135	125
(4)	150	150

12. Paul used a magnet and stroked a steel bar as shown in the diagram below.

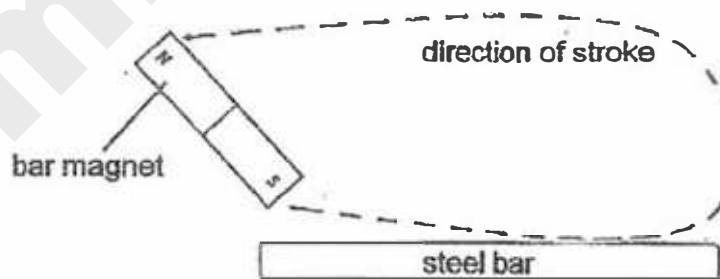

After 40 strokes, he brought the steel bar close to a bowl of steel paper clips. He noticed that a few paper clips were attracted by the steel bar. He would like to attract more paper clips.

Which of the following actions would allow him to do so?

- (1) Replace the steel bar with a copper rod.
- (2) Use paper clips made of Iron instead of steel paper clips.
- (3) Stroke the steel bar with the bar magnet in another direction.
- (4) Stroke the steel bar in the same manner more times with the bar magnet.

13. Study the flow chart below.

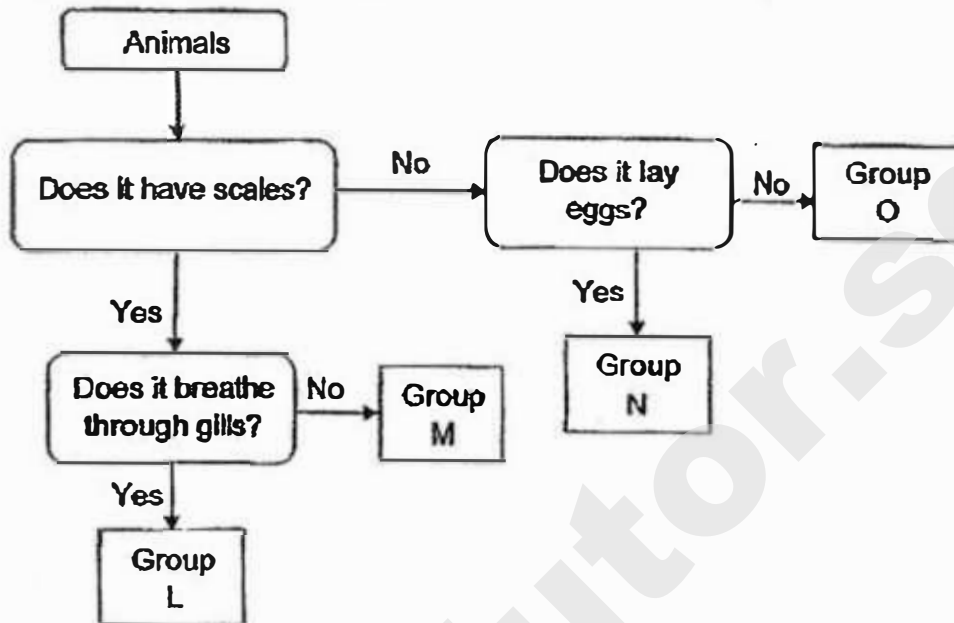

Which group do insects belong to?

- (1) Group L
- (2) Group M
- (3) Group N
- (4) Group O

14. Jane conducted an experiment to investigate the property of a material. She placed the material over two wooden blocks for support and placed a heavy load on the material.

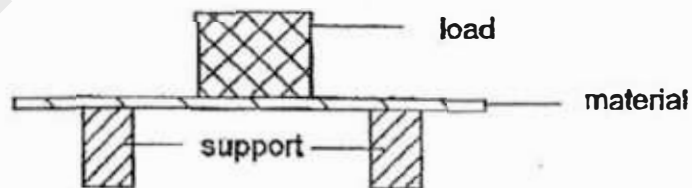

She then increased the mass of the load placed on the material until it broke.

What property of the material was Jane investigating?

- (1) Strength
- (2) Flexibility
- (3) Transparency
- (4) Ability to float

15. An unknown substance is a solid at room temperature. The substance is then heated and the changes in temperature are shown in the graph below.

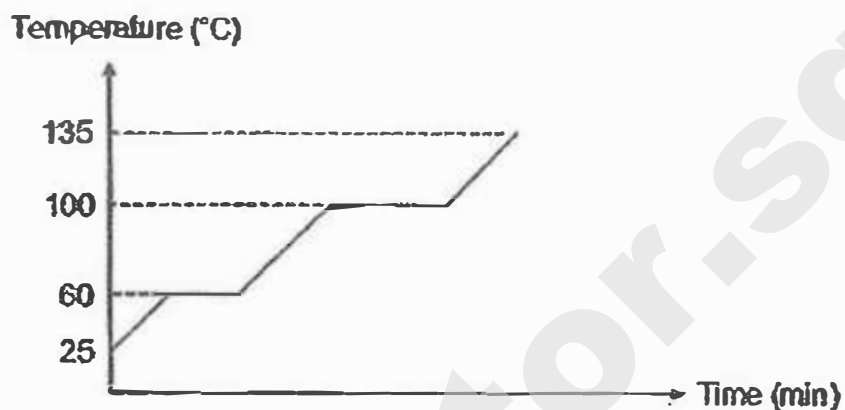

- Which of the following shows the melting point of the unknown substance?
- (1) 25°C
 - (2) 60°C
 - (3) 100°C
 - (4) 135°C
16. The table below shows the melting point and boiling point of three different substances X, Y and Z.

Substance	Melting point (°C)	Boiling point (°C)
X	-50	24
Y	-10	62
Z	49	120

Which of the substances will exist as a liquid at 50°C?

- (1) Y only
- (2) X and Z only
- (3) Y and Z only
- (4) X, Y and Y

17. Which of the following ways of conserving water involves the reuse of water?

- (1) Turn off the tap while brushing your teeth.
- (2) Use water from washing machine for flushing the toilet.
- (3) Wash vegetables in a filled sink instead of using a running tap.
- (4) Use a bucket of water to wash a car instead of using a water hose.

18. The diagram below shows the distribution of plants P, Q and R in an area at the beginning and at the end of the year.

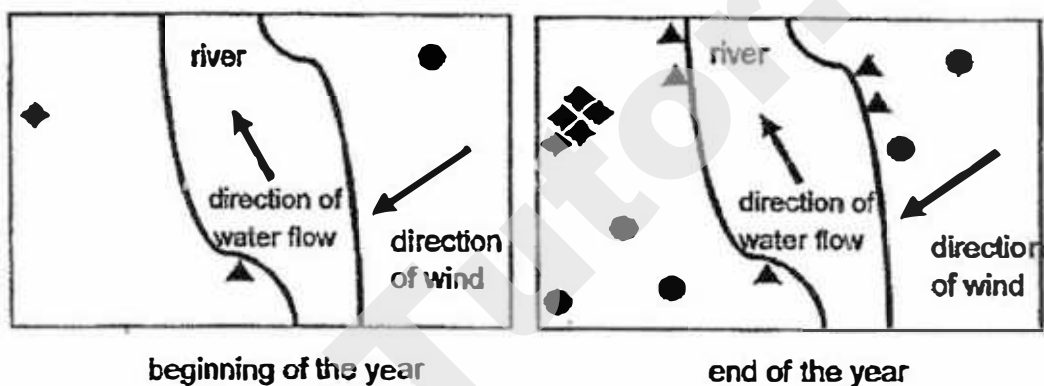

Legend:

◆	plant P
▲	plant Q
●	plant R

Which of the following describes how each plant disperses its seeds correctly?

	Plant P	Plant Q	Plant R
(1)	Water	Explosive action	Wind
(2)	Wind	Water	Explosive action
(3)	Explosive action	Water	Wind
(4)	Explosive action	Wind	Water

19. The diagram below shows a seed.

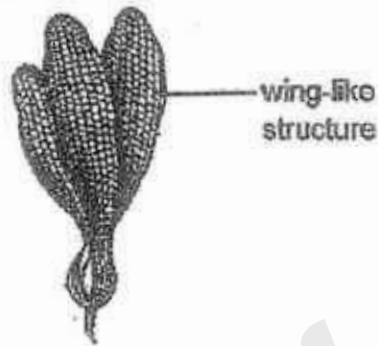

Which of the following statements about the seed could be true?

- A. It came from a fruit which is sweet and fleshy.
- B. It is able to travel far away from its parent plant.
- C. It can be dispersed further if the parent plant is very tall.

- (1) A only
- (2) B only
- (3) B and C only
- (4) A, B and C

20. A measuring cylinder is filled with 100 cm^3 of water. When objects A, B and C are placed in the measuring cylinder, the readings of the water level in the measuring cylinder are recorded, as shown below.

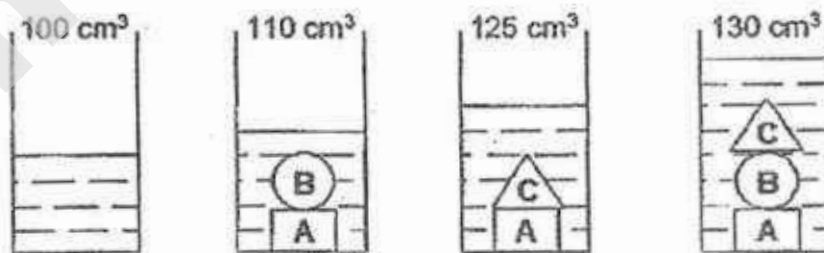

What is the volume of object A?

- (1) 5 cm^3
- (2) 10 cm^3
- (3) 15 cm^3
- (4) 20 cm^3

21. The graph below shows the number of mosquito larvae found in Sean's pond over a period of time.

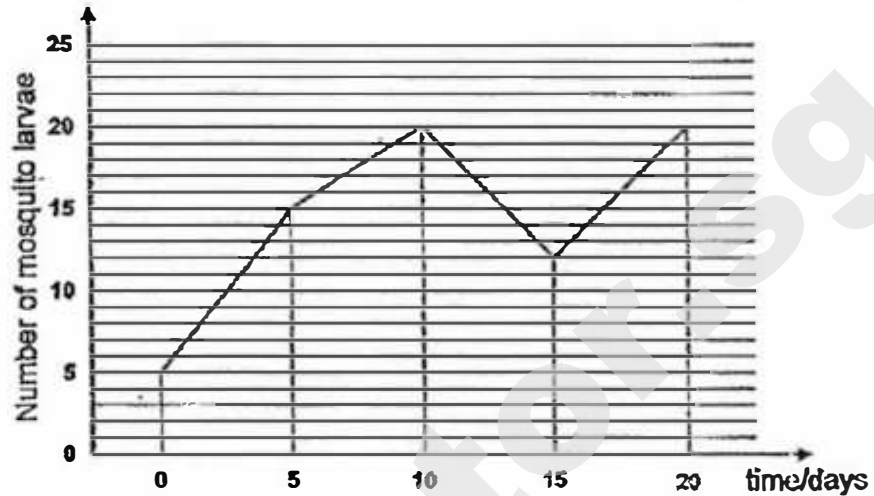

With reference to the data given in the graph, which of the following statements are possibly correct?

- A. The mosquito eggs took 15 days to hatch.
 - B. More mosquito eggs hatched after Day 15
 - C. The mosquito larvae started to die from Day 5.
 - D. Some mosquito larvae changed into pupae from Day 10.
- (1) A and C only
(2) A and B only
(3) B and D only
(4) C and D only

22. Which of the following graphs shows the correct amount of undigested food as it leaves the different organs in the human digestive system?

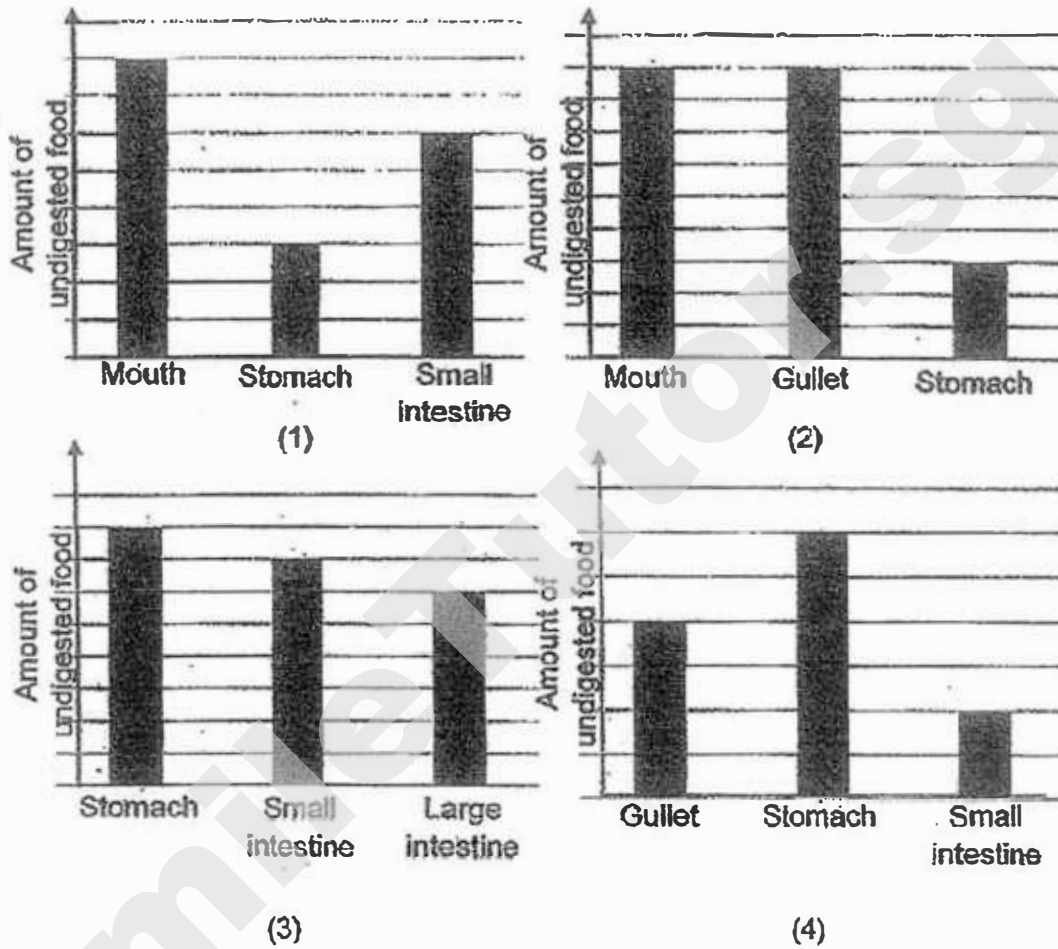



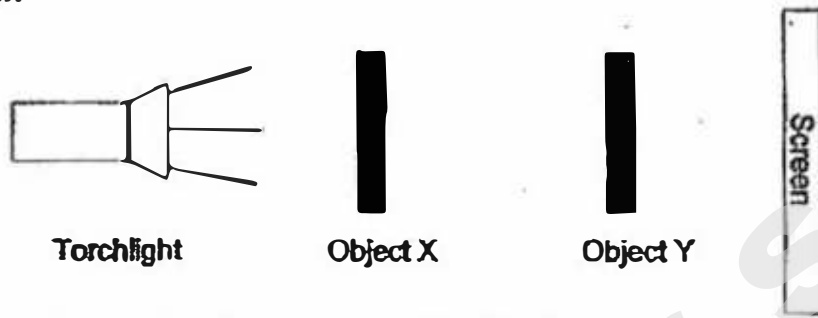





23. A torchlight is shone onto two objects of equal sizes and a screen as shown below.



The shadow cast on the screen is shown below.



Which of the following shapes could represent object X and Y?

	Object X	Object Y
(1)		
(2)		
(3)		
(4)		

24. A man is given four pails of water of different temperatures.

He puts his hands into one of the pail of water for thirty seconds, takes it out and then place his hands into another pail of water. He repeated this action a few more times and recorded down his observations.



From A to C: hand feels cool
From D to B: hand feels cool!
From D to C: hand feels warm
From D to A: hand feels warm

Based on his observations, which of the following shows the order of the pails of water from the warmest to the coolest?

	warmest	→		coolest
(1)	D	B	C	A
(2)	A	C	B	D
(3)	B	D	C	A
(4)	A	C	D	B

25. Three bar magnets with poles AB, CD and EF can be arranged as shown below.

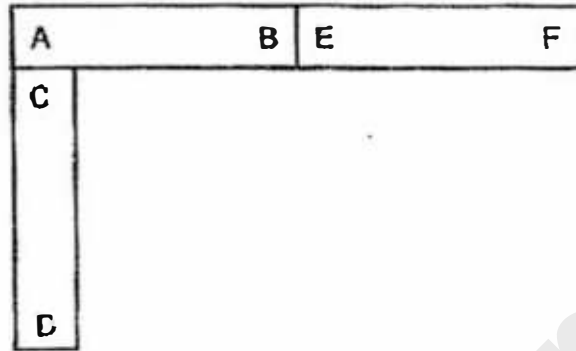

Which of the following arrangement of magnets is not possible?

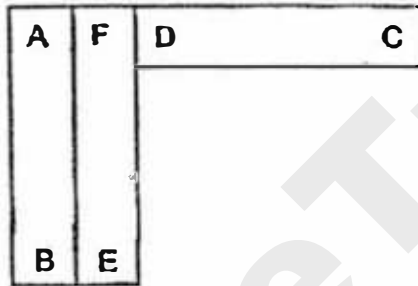

(1)

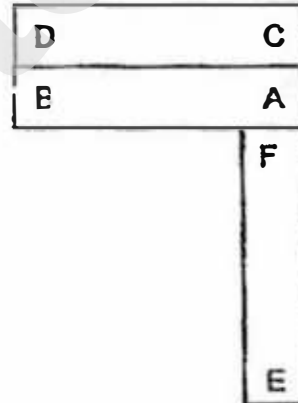

(2)

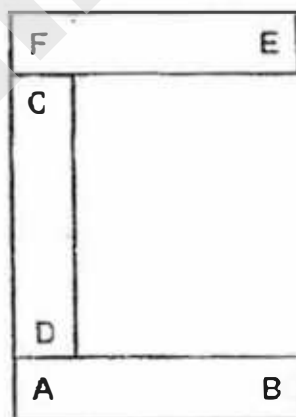

(3)

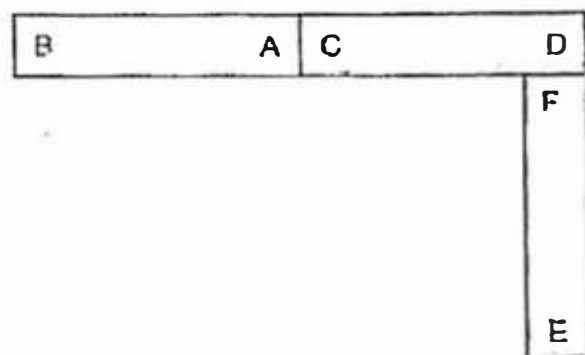

(4)

28. In the set-up shown below, the steel paper clip remains suspended in the middle when the electromagnets are switched on.

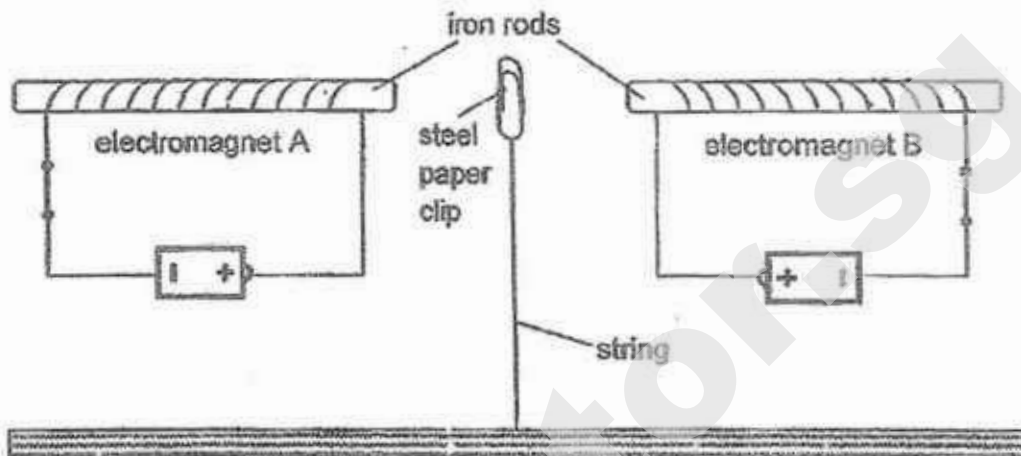

What can be done to pull the paper clip closer to electromagnet A?

- (1) Add one more battery to electromagnet B.
- (2) Use a paper clip made of silver instead of steel.
- (3) Replace the iron rod in electromagnet A with a glass rod.
- (4) Add more coils of wires to the iron rod in electromagnet A.

27. Observe the set-ups shown below. Substance K absorbs water or moisture that is in the air. Each set-up has different conditions provided.

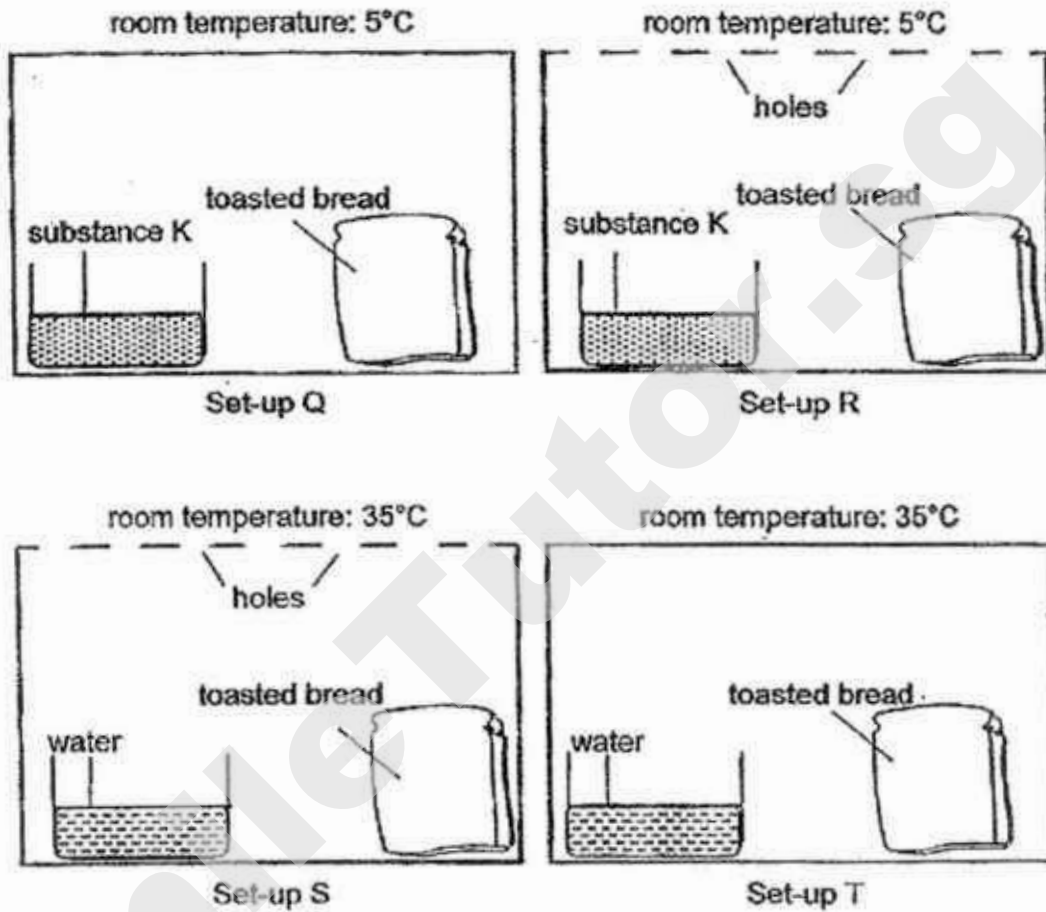

In which of the set-ups above would mould grow on the bread after some time?

- (1) Set-up Q and R
- (2) Set-up Q and T
- (3) Set-up R and S
- (4) Set-up S and T

28. The diagram below shows some characteristics of four different materials, A, B, C and D.

Properties	Materials			
	A	B	C	D
Absorbs water	✓			✓
Strong	✓	✓	✓	
Flexible	✓	✓	✓	✓
Transparent		✓		✓

Which of the above materials is most suitable for making a raincoat?

- (1) A only
- (2) A and D only
- (3) B and C only
- (4) A, B, C and D

END OF BOOKLET A

GO ON TO BOOKLET B

2017 SEMESTRAL ASSESSMENT 1
PRIMARY 5 SCIENCE
(BOOKLET B)

Name : _____ ()

Class : Primary 5 _____

Date : 9 May 2017

Total Duration for Booklets A and B : 1 h 45 min

INSTRUCTIONS TO CANDIDATES:

1. Do not turn over this page until you are told to do so.
2. Follow all instructions carefully.
3. Answer all questions.
4. Write all your answers in this booklet.

Booklet	Marks Obtained	Max Marks
A		56
B		44
Total		100

Parent's Signature : _____

This booklet consists of 15 printed pages.

BOOKLET B : [44 marks]

For questions 29 to 41, write your answers in this booklet.

The number of marks available is shown in the brackets [] at the end of each question or part-question.

29. The diagram below shows the changes in the state of water during the water cycle.

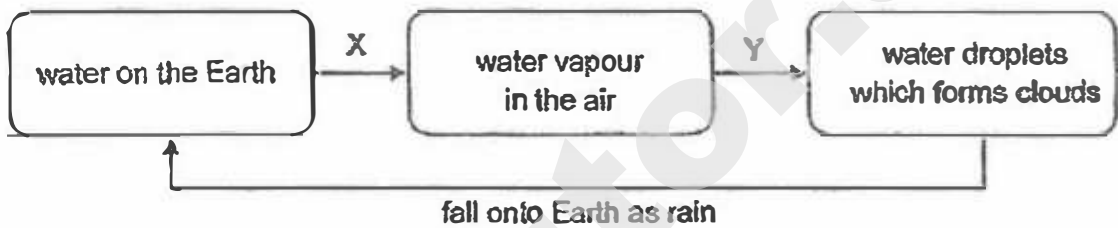

- (a) Name the following processes. [1]

(i) X: _____

(ii) Y: _____

- (d) Use the water cycle to explain why clouds are rarely seen in the skies of the deserts. [1]

Marks :

12

30. Joe prepared two set-ups P and Q as shown below. He placed two glass containers into a basin of water at a certain temperature. Then he placed the glass lids at different temperatures on each glass container. The temperatures of the glass lids were maintained throughout the experiment.

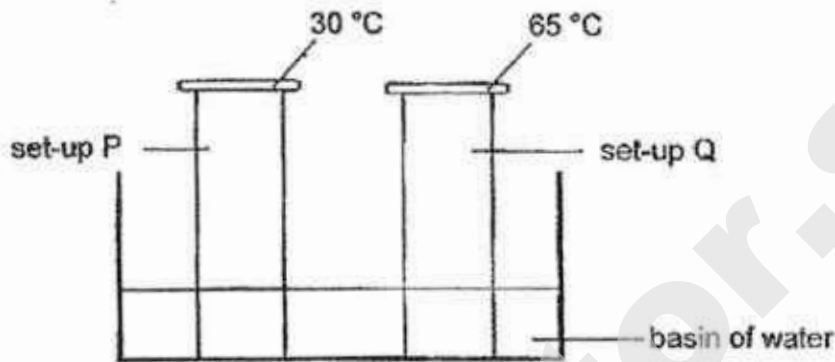

After sometime, he observed that water droplets were formed on the underside of the glass lids inside the glass containers in both set-ups.

- (a) Where did the water droplets formed on the underside of the glass lids come from? [1]

- (b) Three students were discussing about the temperature of the water.

Student	Statement
A	The temperature of the water must be lower than 30°C.
B	The temperature of the water must be higher than 65°C.
C	The temperature of the water must be higher than 30°C but lower than 65°C.

Which student made a correct statement? Explain your answer. [2]

Marks :

/ 3

(c) What do you think could be observed if the temperature of the water in the basin was at 65°C? [1]

(i) at set-up P

(ii) at set-up Q

(d) How did the use of the same basin of water make the experiment a fair test? [1]

31. In an experiment, two identical containers are filled with different amounts of water and left under the hot sun for an hour.



Container A

Container B

Two students then made a prediction at the start of the experiment.

Mary: There will be lesser water in both containers at the end of the experiment.

Tom: Container A will lose more water than container B.

(a) Explain why Mary's prediction is correct. [1]

(b) Is Tom's prediction correct? Explain your answer. [2]

Marks :

15

32 (a) The diagram below shows a flower.

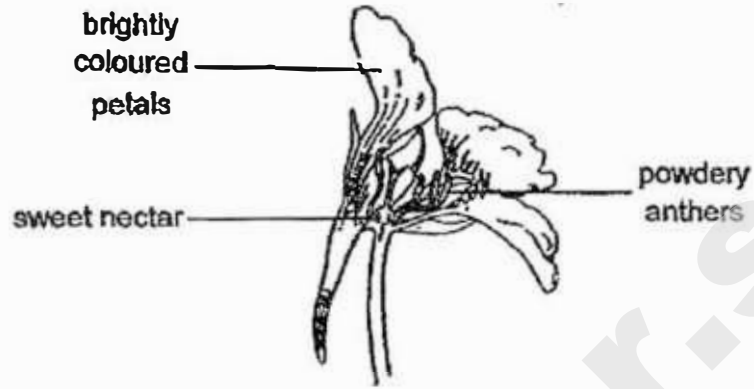

Suggest how this flower is pollinated. Give a reason to support your answer.

[1]

(b) The diagram below shows the cross-section of a flower.

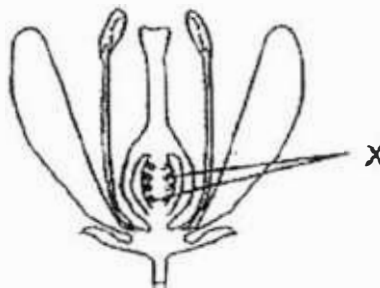

Explain why fertilization will not occur in the flower if Part X is removed.

[2]

Marks :

13

33. The diagrams below show four seeds, Q, R, S and T. The seeds are not drawn to scale.

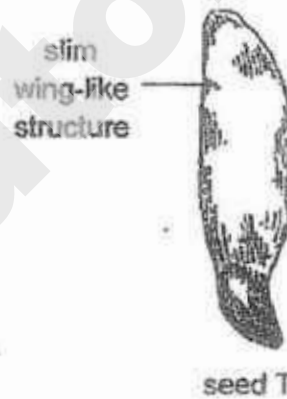
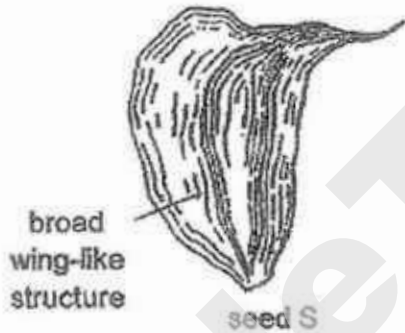
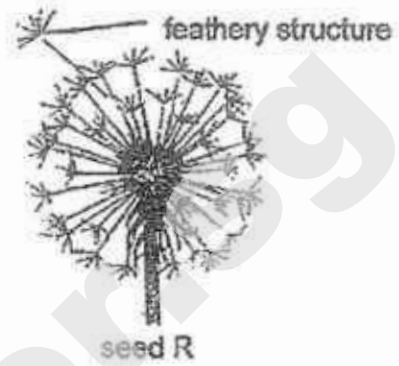
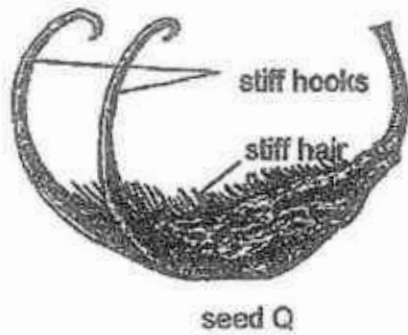

- (a) State the reason why it is important for seeds to be dispersed further away from their parent plant. [1]

- (b) Which one of the seeds is dispersed differently from the rest? Explain how this seed is dispersed. [2]

Seed _____

Dispersed by: _____

Explanation:

Marks :

/ 3

34. Look at the cell shown below carefully.

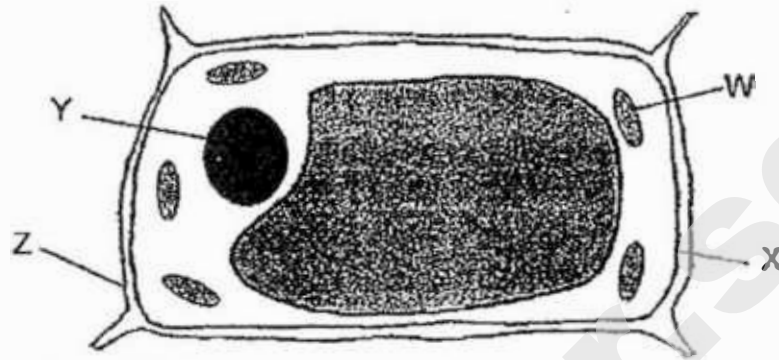

(a) Which part of the cell which controls all activities inside the cell?
Name this part. [1]

(b) State the function of the part W of the cell shown above. [1]

(c) Is the cell above a plant cell or an animal cell? Explain your answer. [1]

Marks :

/ 3

35. The diagram below shows a section of the branch from which the food-carrying tubes have been removed. The removal of these tubes help the plants grow bigger fruits.

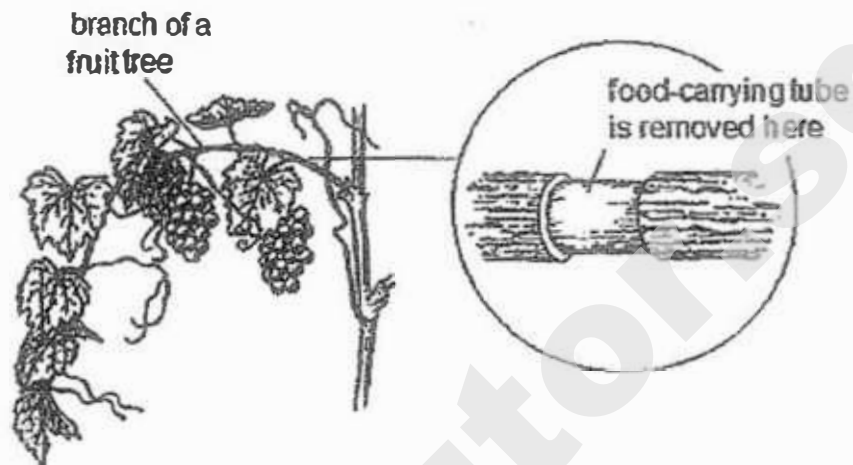

- (a) Explain why the farmers must be careful not to remove the water-carrying tubes as well when they are removing the food-carrying tubes. [1]

- (b) Explain how removing the food-carrying tube will allow the fruit to grow bigger. [2]

Marks :

/ 3

36. Sam carried out an experiment on four similar basketballs of the same size.

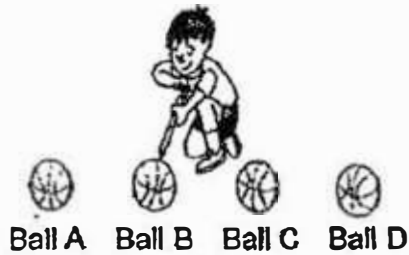

He inflated the four basketballs with different amounts of air with a bicycle pump and recorded his results in the table below. The volume of the inflated basketballs remained the same.

Ball	Number of times the ball has been pumped	Mass of ball after being inflated (g)
A	30	250
B	35	262
C	40	274
D	45	286

(a) State a variable that has been changed in the above experiment. [1]

(b) Based on the experiment, explain why air is a matter. [1]

(c) State the property of air which allowed the above experiment to be carried out. [1]

(d) What do think would happen to the basketballs if Sam had carried out the above experiment by pumping water instead of air into the basketball? Explain your answer. [1]

Marks : / 4

37. Study the diagram of the human digestive system shown below.

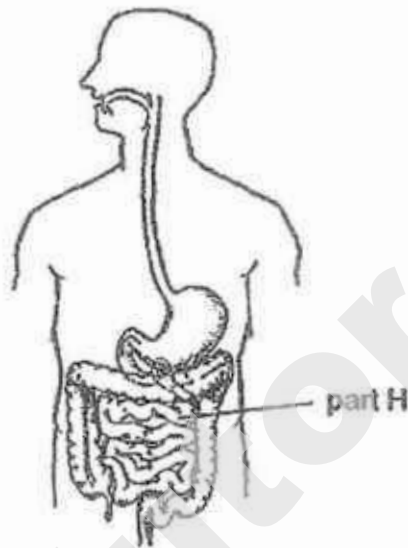

- (a) State how the teeth help in the digestion of food. [1]

- (b) A person can put on weight if the amount of digested food in the blood is too high.

John went for a surgery to shorten part H of his digestive system. Suggest how this would enable him to lose weight. [1]

Marks :

12

38. The graph below shows how the length of three different metals, X, Y and Z, changes with temperature.

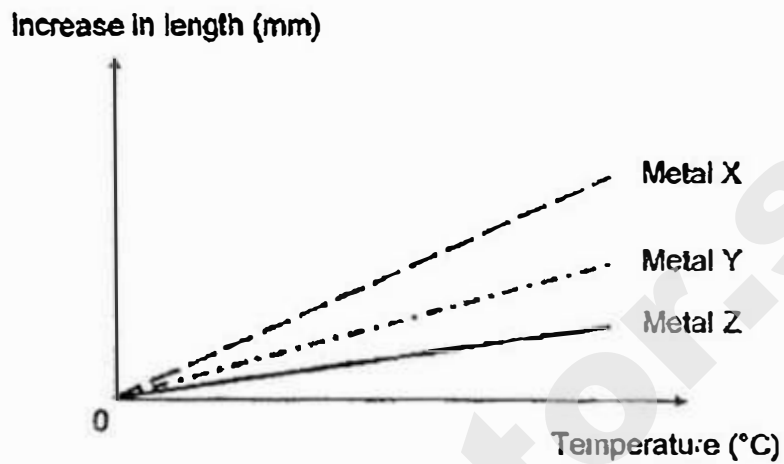

- (a) From the graph, what can you observe about the expansion of the three different types of metals? [1]

- (b) A railway engineer is using one of the metals to make a railway track. Which metal is most suitable for the making the railway track? Explain your answer [2]

Marks :

/ 3

- (c) An engineer is selecting two metals to make a bimetallic strip for a fire alarm. A bimetallic strip is made by joining two different metals together.

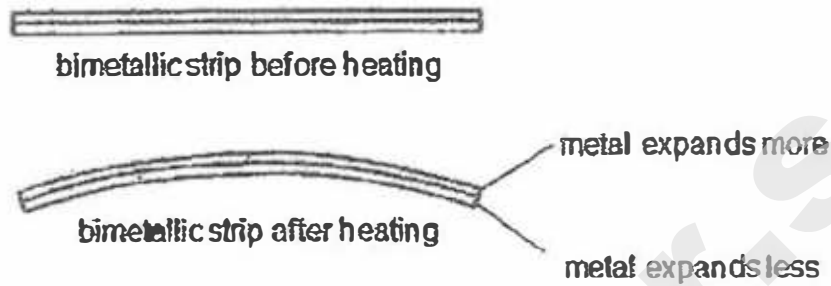

When there is a change in temperature, the two metals will expand at different rates and cause the bimetallic strip to bend towards the metal part that expands the least.

In a fire alarm system, the bimetallic strip will bend and touch the contact when the temperature increases, so that the fire alarm will be sounded.

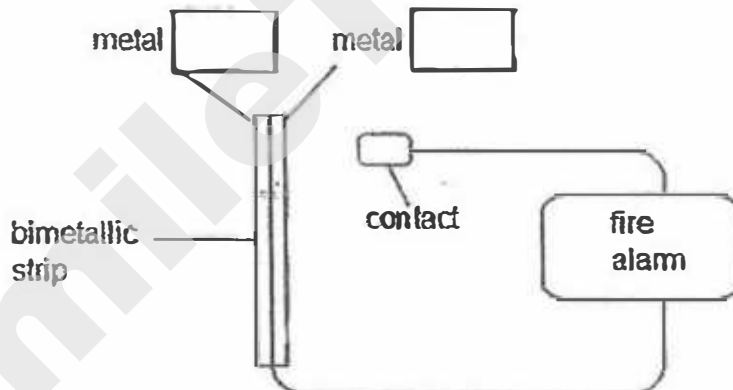

- (i) Label in the boxes in the diagram above, the most appropriate choice of metals to be used for making the bimetallic strip used in the fire alarm system. [1]
- (ii) Explain your choice of metals in (i). [1]

Marks :

12

39. The diagram below shows the set-up of an experiment. A lighted bulb is placed against an object and a shadow is formed on the screen.

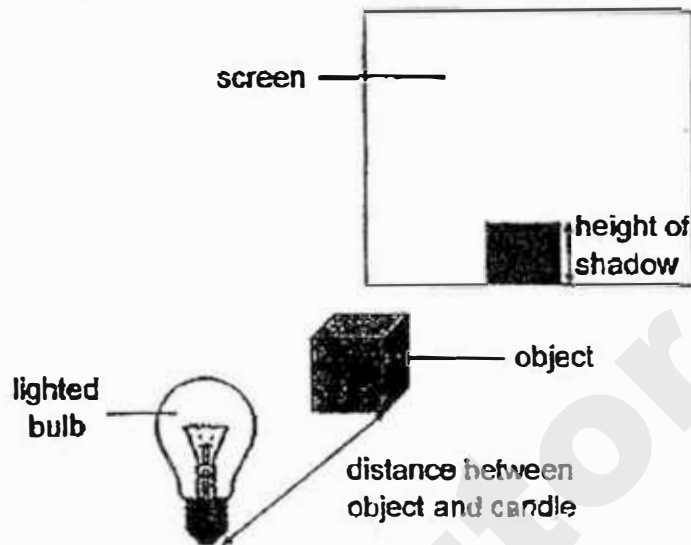

The table below shows the height of the shadow as the distance between the object and the bulb increases.

Distance between object and lighted bulb (cm)	Height of shadow (cm)
10	14
15	9
20	6

- (a) State the reason why the shadow is formed by the object. [1]

- (b) What is the aim of the experiment? [1]

- (c) Based on the results, what is the relationship between the height of the shadow formed and the distance between the bulb and the object? [1]

Marks : / 3

- 40: Two objects, K and L, were placed hanging on a balance as shown in the diagram below. A magnet is brought near to each object and the observation was recorded below.

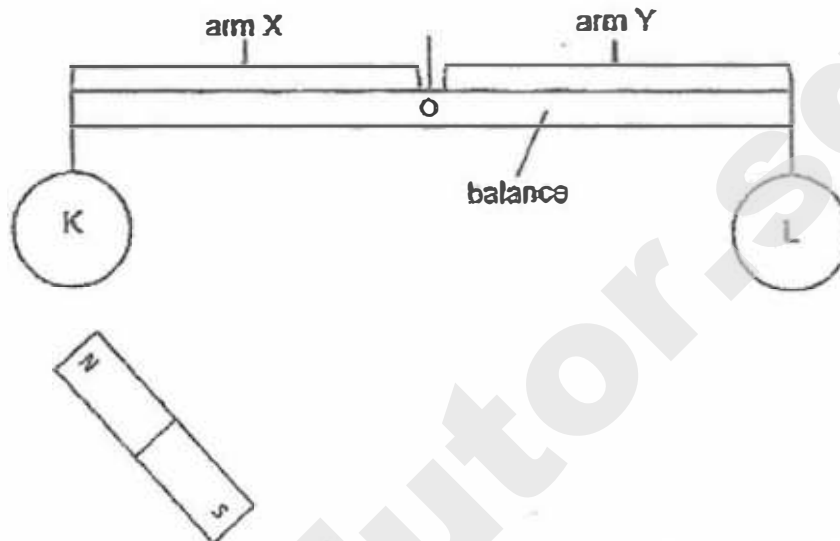

	Observation	
	Object K	Object L
When magnet was brought near object	Nothing happened	Arm Y tilted downwards

- (a) What does this observation tell you about object K? Explain your answer. [2]

- (b) John suspects that object L is a magnet. Suggest a way for him to confirm that using the same materials in the experiment. [1]

- (c) Explain your answer in (b). [1]

Marks : / 4

41. (a) John has designed his own bicycle, as shown below, to ride to school.

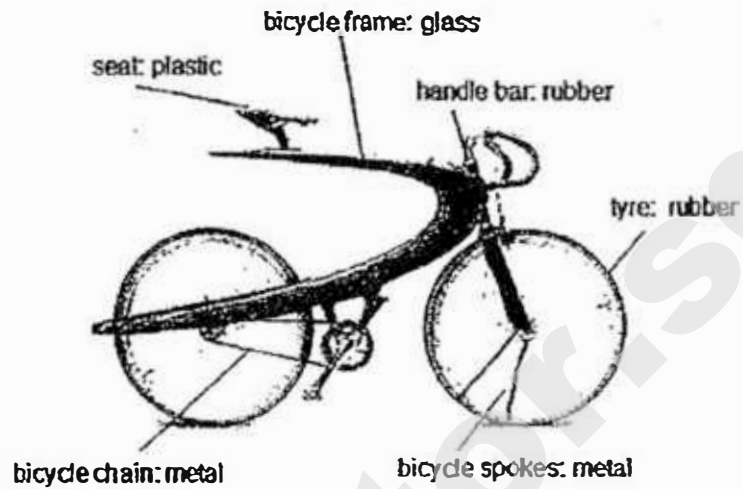

His bicycle will not function properly as he is not using the correct materials for his bicycle.

In the table below, tick the part(s) of the bicycle where John has indicated material(s) which is/are unsuitable and state the **useful properties** of material that should be used instead. [2]

Parts of bicycle	Put a tick if the material(s) used is/are unsuitable.	Useful properties of materials that can be used to replace the material(s) of the part(s) that you have ticked.
bicycle chain		
bicycle frame		
bicycle spokes		
handle bar		
seat		
tyre		

Marks : / 2

(b) The diagram below shows a cooking pot.

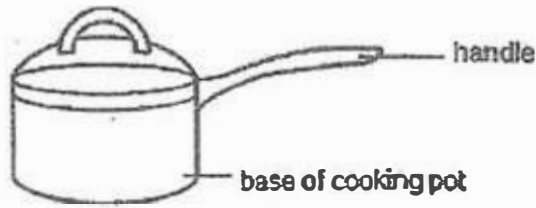

The graph below shows the temperature of the materials R, S and T as they are heated over time.

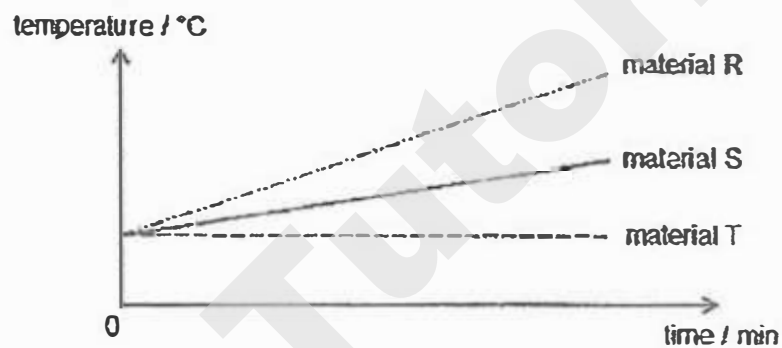

(i) Which material, R, S or T, is best for making the base of the cooking pot? Explain your answer. [1]

(ii) Which material, R, S or T, is best for making the handle of the cooking pot? Explain your answer. [1]

~ END OF PAPER ~



Marks :

YEAR : 2017
LEVEL : PRIMARY 5
SCHOOL : MAHA BODHI SCHOOL
SUBJECT : SCIENCE
TERM : SA1

Booklet A

Q1	C2	Q3	Q4	Q5	Q6	Q7	Q8	Q9
2	1	1	3	4	4	4	4	1
Q10	Q11	Q12	Q13	Q14	Q15	Q16	Q17	Q18
1	2	4	3	1	2	3	2	3
Q19	Q20	Q21	Q22	Q23	Q24	Q25	Q26	Q27
3	1	3	2	4	4	3	4	4
Q28								
3								

Booklet B

Q29a X : Evaporation
 Y : Condensation

Q29b There is not much water in the desert to gain heat and evaporate into the sky , hence there will be lesser water vapour to be condensed into tiny water droplets to form clouds in the sky of the desert.

Q30a Warmer water vapour in the glass container lose heat and condensed into water droplets when it came into contact with the cooler underside of the glass lids.

- Q30b Student B. The warmer water in the basin heats up the water in the glass containers, causing them to gain heat and evaporate into water vapour, and when the warmer water vapour touches the cooler underside of the glass lid, it loses heat and condense into tiny water droplets.
- Q30c (i) Lesser water droplets are observed.
(ii) No water droplets are observed.
- Q30d It makes sure that there is only one change variable.
- Q31a The water in the containers would gain heat and evaporate.
- Q31b No. The exposed surface area of water in both containers are the same, hence the rate of evaporation will be the same.
- Q32a The flower is pollinated by animals. It has brightly coloured petals to attract animals.
- Q32b Part X are the ovules, and the ovules produce the egg cell. Without it, there no egg cells would be produces and the male reproductive cell would not be able to fertilise it, hence fertilisation will not occur in the flower if Part X is removed.
- Q33a It is to prevent overcrowding which results in competition for water, nutrients, sunlight and space.
- Q33b Seed Q
Dispersed by: Animals
Explanation: The seeds have stiff hooks and hairs that allow it to be attached to the outer covering of animals.
- Q34a Part Y. It is the Nucleus.

- Q34b** Part W contains chlorophyll that helps the plant to trap sunlight for photosynthesis.
- Q34c** It is a plant cell. It has a cell wall and plant cells have a cell wall.
- Q35a** Water-carrying tubes carry water to the leaves, and the leaves would die without water.
- Q35b** Food made by the leaves would only be supplied to the fruits as the food would be stuck.
- Q36a** The number of times the ball has been pumped.
- Q36b** The mass of the basketball increases with the amount of air pumped in, hence air has mass and occupies space.
- Q36c** Air can be compressed.
- Q36d** The basketballs would burst. Unlike air, water cannot be compressed.
- Q37a** The teeth cut the food into smaller pieces and digest it partially.
- Q37b** Less food would be digested, as when the small intestine is shortened, lesser digested food is absorbed into the blood streams.
- Q38a** Metal X expanded the most while Metal Z expanded the least.
- Q38b** Metal Z. Metal Z expanded the least among the three metals, hence it would prevent the railway track from buckling easily in the hot sun.

- Q38c (i) Metal X Metal Z
(ii) The bimetallic strip will expand more and touch the contact.
- Q39a The object blocks the path of light.
- Q39b To find out if the height of the shadow decreases as the distance between the object and the bulb is further.
- Q39c The closer the distance between the bulb and the object, the taller the shadow.
- Q40a Object K is a non-magnetic material. Magnets only attract Magnetic materials.
- Q40b He could bring the other pole of the magnet closer to the object.
- Q40c Only magnets with like-poles facing each other would repel.
- Q41a

Parts of Bicycle	Put a tick if the material(s) used is/are unsuitable	Useful properties of materials that can be used to replace the materials(s) of the parts(s) that you have ticked
bicycle chain		
bicycle frame	√	It cannot break easily
bicycle spokes		
handle bar	√	It is stiff not flexible
seat	√	It is soft and strong
tyre		

Q41b

(i) Material R. It is the best conductor of heat among the three materials and would allow the food to get cooked the fastest.

(ii) Material T. It was the poorest conductor of heat among the three objects and would prevent the holder from getting burnt easily.

SmileTutor.sg

SEMESTRAL ASSESSMENT 1 – 2017
PRIMARY 5

SCIENCE

BOOKLET A

28 Multiple Choice Questions (56 marks)

Total Time for Booklets A and B : 1 hour 45 minutes

INSTRUCTIONS TO CANDIDATES

1. Write your name and index number in the space provided.
2. Do not turn over the page until you are told to do so.
3. Follow all instructions carefully.
4. Answer all questions.
5. Shade your answers in the Optical Answer Sheet (OAS) provided.

Marks Obtained

Booklet A	/ 56
Booklet B	/ 44
Total	/ 100

Name: _____ ()

Class: P 5 _____

Date : 3 May 2017

Parent's Signature: _____

Section A: (28 x 2 marks = 56 marks)

For each question from 1 to 28, four options are given. One of them is the correct answer. Make your choice (1, 2, 3 or 4). Shade the correct oval (1, 2, 3 or 4) on the Optical Answer Sheet.

1. Which statement(s) about the cells in our body is/are true?

- A Each cell is a basic unit of life.
- B Every cell has a special function.
- C Each cell need food, water and oxygen.

- (1) A only
- (2) B only
- (3) A and B only
- (4) A, B and C

2. Scientists collect seeds and place them in seed bank. These seeds could be germinated when plants die during natural disasters. This method shows that seeds are important in the reproduction of plants because they ensure that _____.

- (1) the plants of their own kind can continue to grow
- (2) offspring have characteristics of the parent plants
- (3) seedlings can be grown under favourable conditions
- (4) young plants are dispersed far away from parent plants

3. Study the diagram below carefully.

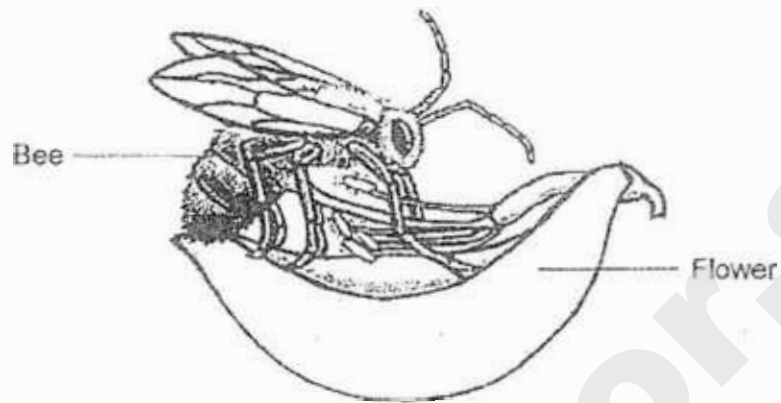

Which one of the following processes of sexual reproduction in flowering plants is shown in the above diagram?

- (1) Pollination
- (2) Fertilisation
- (3) Germination
- (4) Seed dispersal

4. The diagram below shows the female reproductive system of a flowering plant.

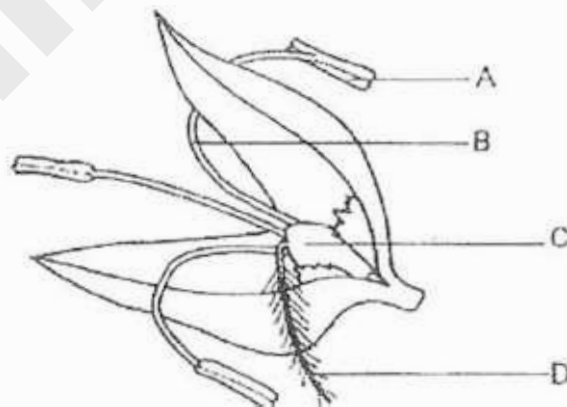

Which part of the system has the same function as the ovary found in human?

- (1) A
- (2) B
- (3) C
- (4) D

5. A stalk of flower was placed overnight in a beaker of water that was dyed blue in colour.

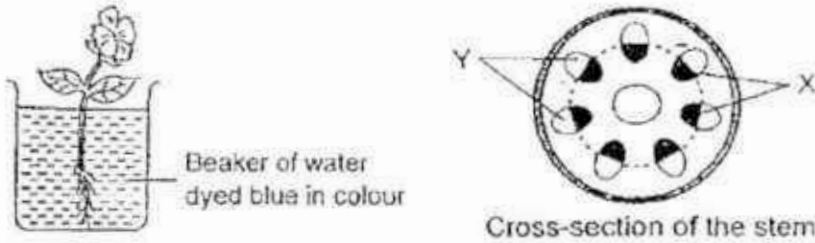

After the experiment, the stem of the stalk of flower was cut to show the cross-section as shown above. The areas, X, turned blue.

Which of the following about X and Y is correct?

	X	Y
(1)	Transports food	Transports water and mineral salts
(2)	Transports food and mineral salts	Transports air and water
(3)	Transports water and mineral salts	Transports food
(4)	Transports air and water	Transports food and mineral salts

6. What are the main parts of our respiratory system?

- (1) mouth, ribs and lungs
- (2) nose, windpipe and lungs
- (3) mouth, windpipe and lungs
- (4) nose, windpipe, ribs and lungs

7. The following pictures show the various systems in a human body.

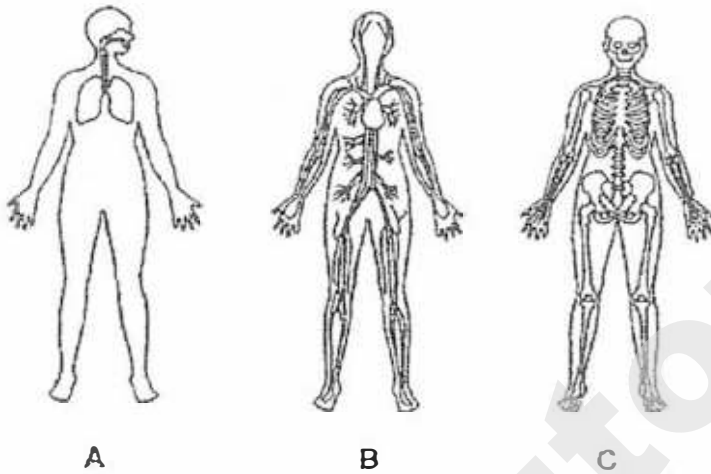

Which of the system(s) above continue to function when you are sleeping at night?

- (1) A only
- (2) B only
- (3) A and B only
- (4) A, B and C

8. Study the diagram below carefully.

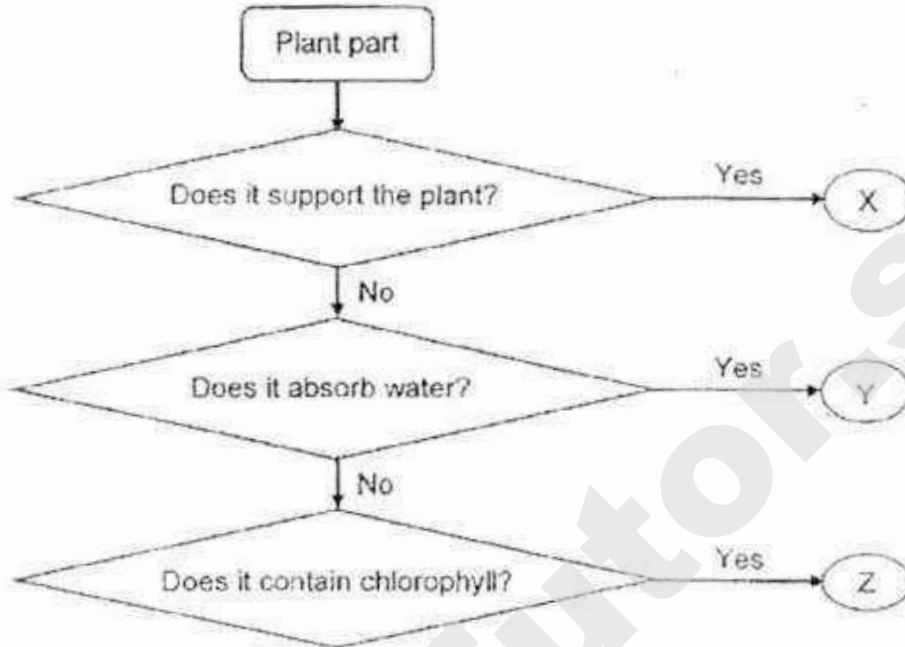

Which of the following shows what X, Y and Z represent respectively?

	X	Y	Z
(1)	root	leaf	stem
(2)	root	stem	leaf
(3)	stem	leaf	root
(4)	stem	root	leaf

9. Study the set-up below carefully. Some starch solution is placed into a plastic bag and dipped into a basin of iodine solution. Iodine solution turns dark blue when it comes into contact with starch. After one hour, the starch solution in the plastic bag turned dark blue but the iodine solution in the basin remained unchanged.

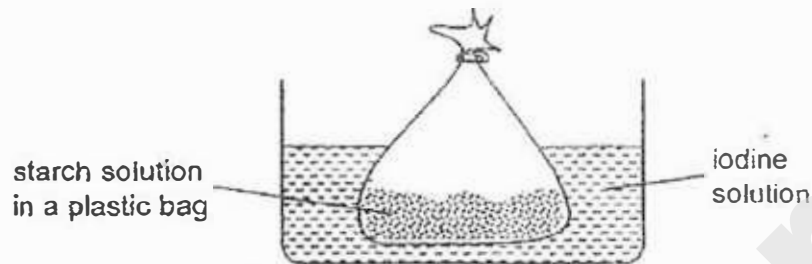

Which part of the cell could be represented by the plastic bag to explain what had happened in the experiment?

- (1) Nucleus
- (2) Cytoplasm
- (3) Chloroplasts
- (4) Cell Membrane

The diagram below shows the distribution of plants W, X, Y and Z.

Questions 10 and 11 are based on the diagram.

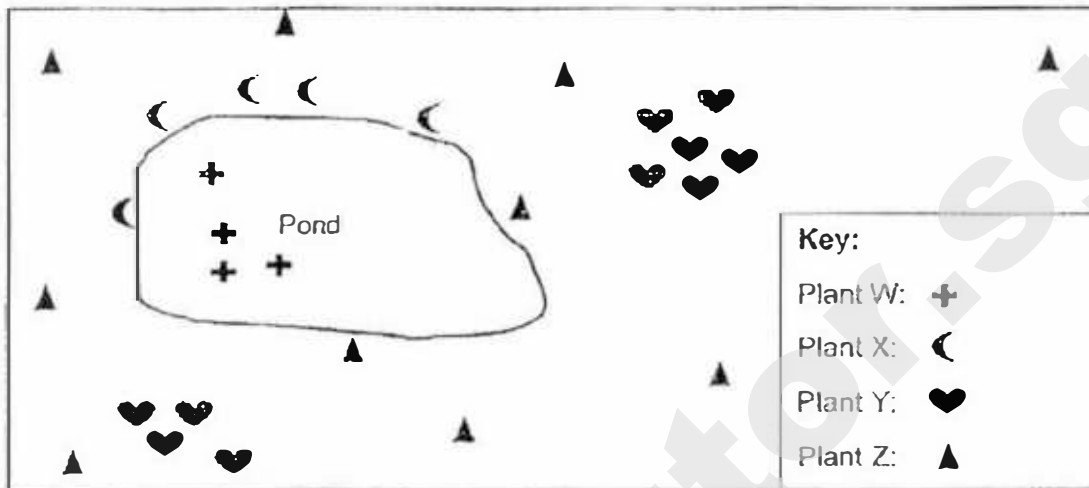

10. Which of the following plant has fruits with stiff hairs?

- (1) Plant W
- (2) Plant X
- (3) Plant Y
- (4) Plant Z

11. The following statements describe the plants.

- A: Seeds of Plant Y may have wing-like structures.
- B: Fruits of Plant W and Plant X have fibrous parts.
- C: Plant Y experiences higher chances of overcrowding

Based on your observations of the diagram above, which statement(s) is/are most likely to be correct?

- (1) A only
- (2) A and B
- (3) B and C
- (4) A, B and C

12. Which diagram shows the correct movement of food in a germinating seed?

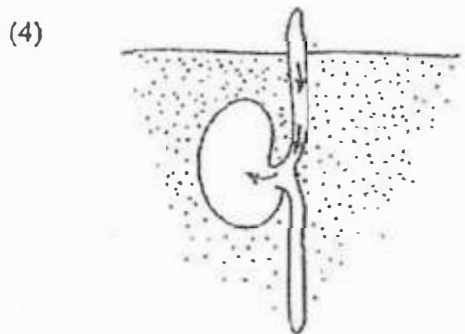
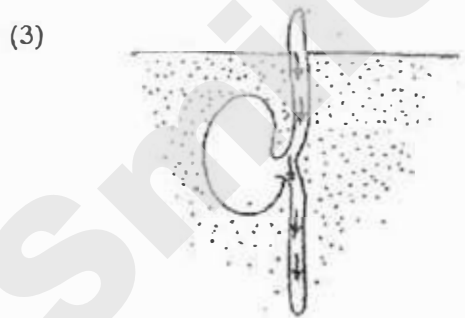
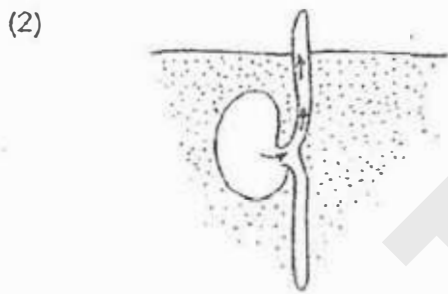
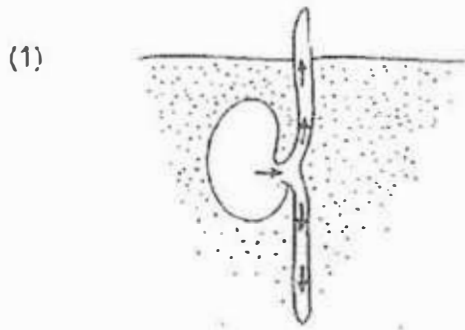

3. The female reproductive system usually releases one egg every month. A woman eats substance X regularly to increase chances of fertilisation. Substance X most likely works by increasing _____.

- (1) the size of the womb
- (2) the number of sperms produced by the testes
- (3) the number of eggs released by the ovaries monthly
- (4) the number of ovaries in the female reproductive system

4. The diagram below shows a lizard kept in a sealed glass jar.



Which one of the graphs below shows how the amount of oxygen and carbon dioxide changed over fifteen minutes?

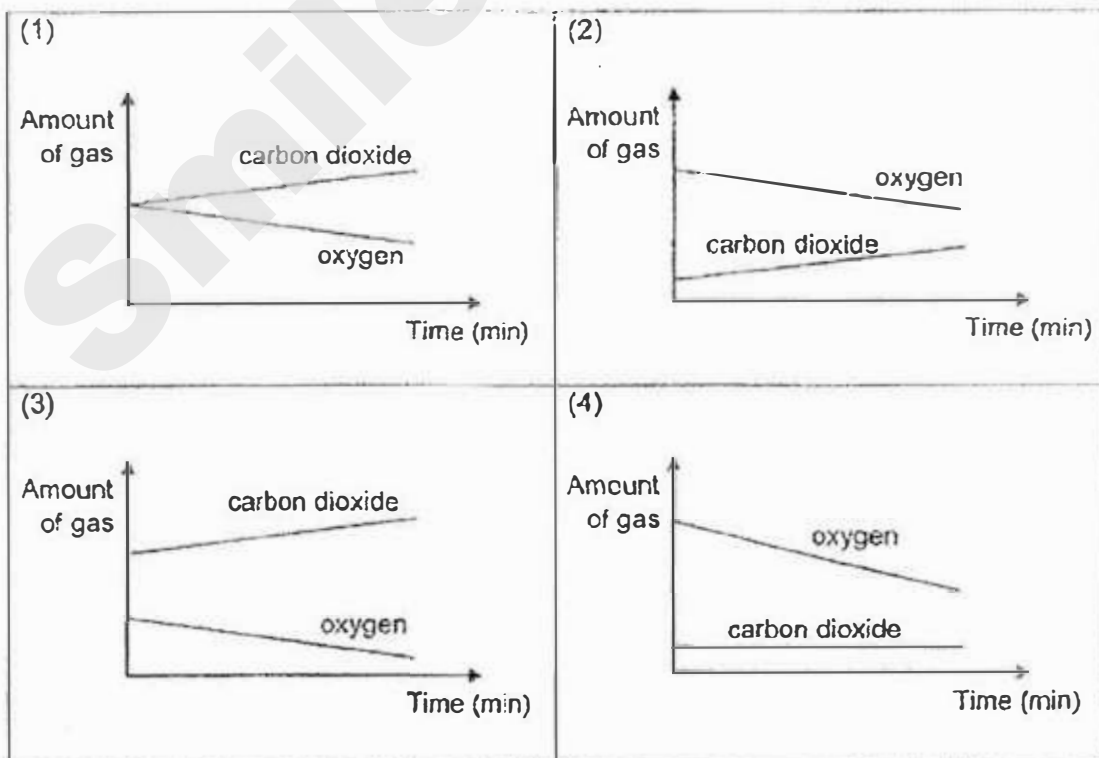

15. The diagrams below show the respiratory systems of a human and a fish.

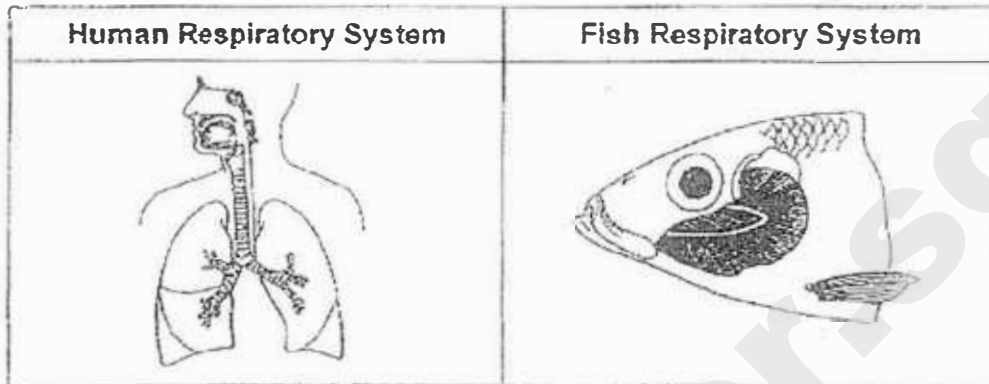

Which statement(s) about the human and fish respiratory systems is/are correct?

- A Both systems take in oxygen and release carbon dioxide into the air.
 - B Gaseous exchange occur in the lungs of the human and at the gills of the fish.
 - C The human take in air through the nose but the fish take in water through the mouth.
- (1) A only
(2) B only
(3) A and C only
(4) B and C only
16. Which of the following statements correctly describe what happens to the food in the mouth before it is swallowed?
- A The food is dissolved in saliva.
 - B The food becomes moist and slippery.
 - C The food is broken up into smaller pieces.
 - D The food is starting to be broken down into simple substance.
- (1) A and B only
(2) C and D only
(3) A, B and C only
(4) B, C and D only

17. The diagram below shows how food travels in our body.

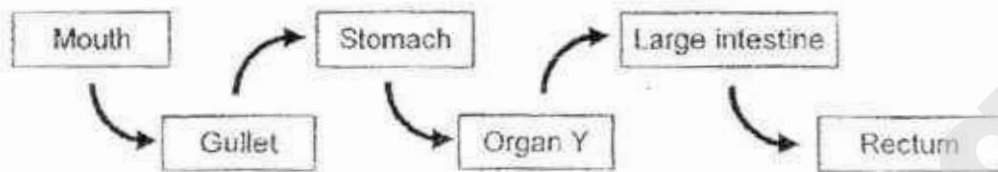

What happens if Organ Y is not working?

- A More digestive juice cannot be added.
- B Water cannot be absorbed into the bloodstream.
- C Digested food cannot be absorbed into the blood stream.

- (1) A and B only
- (2) A and C only
- (3) B and C only
- (4) A, B and C

18. The diagram below shows four objects.

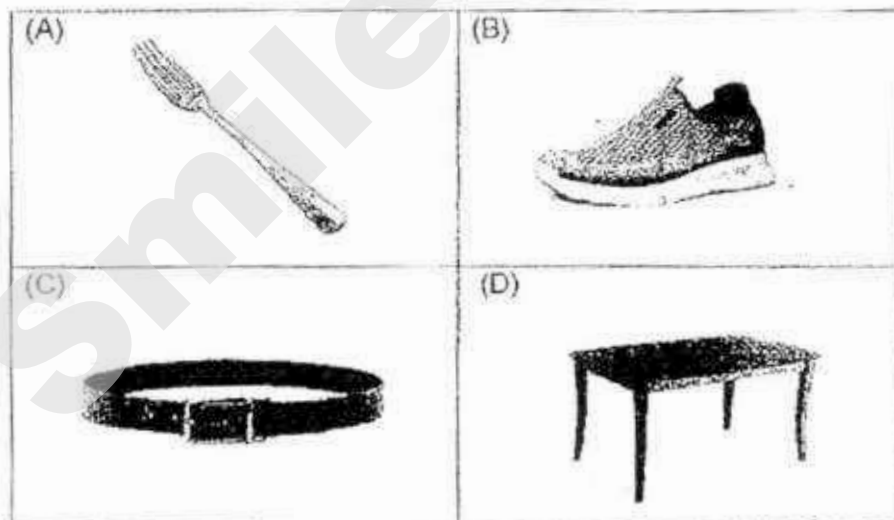

Which objects above have to be made of a flexible material?

- (1) A and D only
- (2) B and C only
- (3) A, B and C only
- (4) B, C and D only

19. Five magnets are connected as shown in the diagram below.

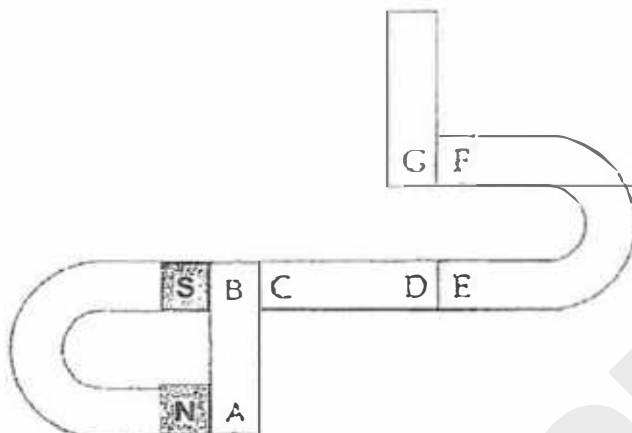

What are the poles of A, D, F and G respectively?

	A	D	E	G
(1)	South	North	South	South
(2)	North	South	North	North
(3)	South	North	North	South
(4)	North	South	North	North

20. The diagram below shows the water cycle.

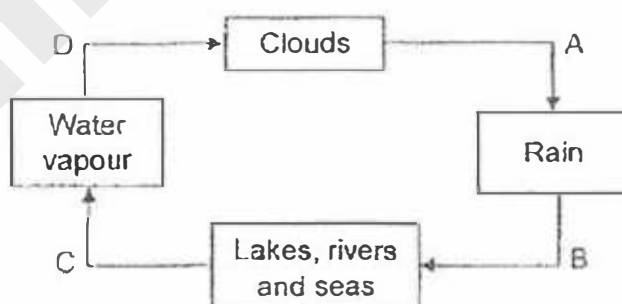

Which statement(s) about the water cycle is/are true?

- A The Sun provides the heat for processes C and D.
- B Plants and animals also provide the water vapour for the water cycle.
- C Only process B ensures a constant supply of water to lakes, rivers and seas.

- (1) A only
- (2) B only
- (3) A and B only
- (4) B and C only

21. Sally carried out an experiment to test the strength of four materials for making fishing lines. She added weights of 2 kg to the strings made of the four different materials until the strings broke.

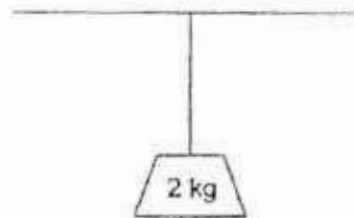

Sally recorded the results in the table below.

Number of weights added until the string breaks			
String W	String X	String Y	String Z
3	7	4	5

To catch a fish of more than 10 kg, which string should Sally use?

- (1) String W
- (2) String X
- (3) String Y
- (4) String Z

22. The diagram below shows paper bags used by many shops. Paper is made from wood that comes from trees that will not pollute the earth unlike plastic bags.

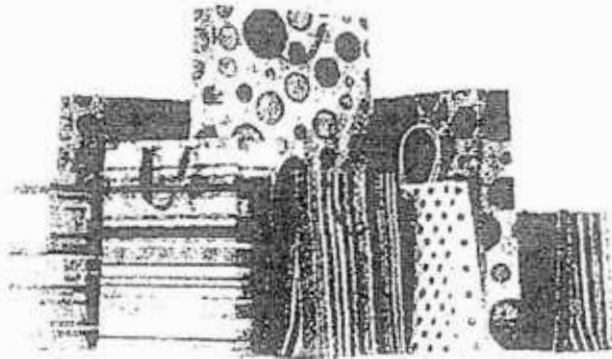

The supermarkets that use a lot of plastic bags should consider changing to paper bags to reduce pollution.

Which property/properties of plastic is/are the possible reason(s) why supermarkets continue to use plastic bags instead of paper bags?

- A strong
- B waterproof
- C translucent

- (1) A only
- (2) A and B only
- (3) A and C only
- (4) B and C only

23. Damien placed a piece of cardboard between a paperclip and a magnet.

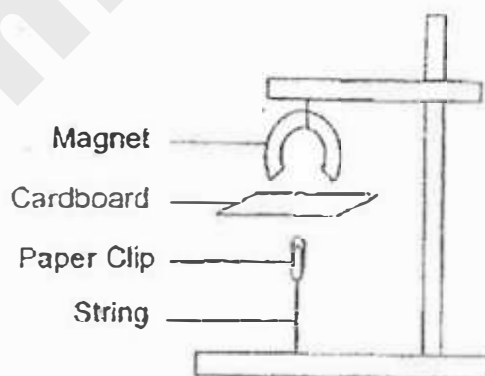

What does the above experiment show?

- (1) The magnet can act at a distance.
- (2) The paper clip is a temporary magnet.
- (3) The string is made of a magnetic material.
- (4) Magnetic force cannot pass through the cardboard.

24. Siti wants to find out how the magnetic strength of a temporary magnet is affected by the number of strokes made by the magnet.

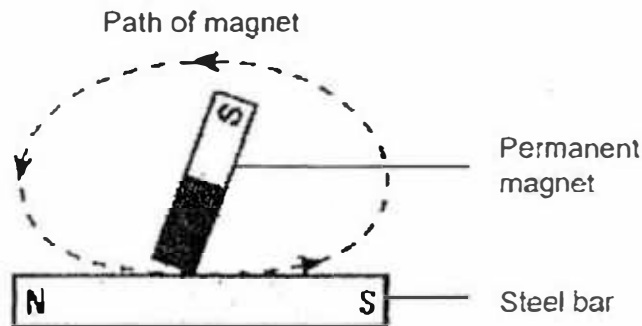

She magnetised four identical steel bars by stroking them with a magnet for different number of times. After each steel bar was magnetised, she placed each steel bar 5 cm above a bowl of pins.

The results of the experiment are recorded in the table below.

Number of strokes received by steel bar	Number of pins attracted		
	1 st attempt	2 nd attempt	3 rd attempt
10	4	3	4
20	5	6	6
30	7	13	8
40	10	10	11

Siti decided that the circled value is unusually high. She removed the reading before calculating the average number of pins picked up for each temporary magnet before making a conclusion. This shows that repeating the experiment increases the _____ of the result.

- (1) fairness
- (2) reliability
- (3) variables
- (4) accuracy

25. The diagram below shows a conveyor belt that is used to separate waste. The roller drum at the end of the conveyor belt is a magnet.

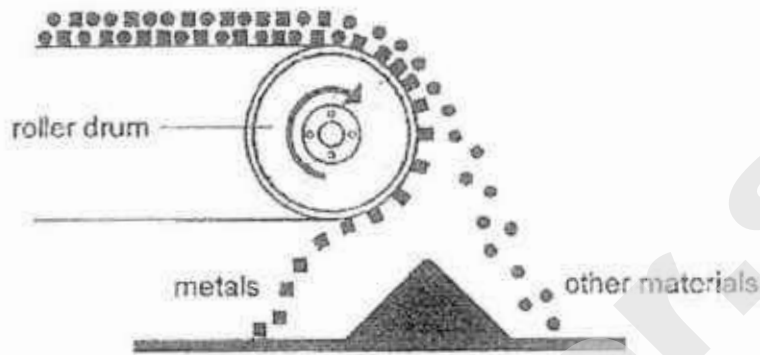

Which option correctly shows the metals and materials separated by the machine?

	Metals	Other materials
(1)	Copper and Iron	Plastic and Paper
(2)	Iron and Steel	Glass and Plastic
(3)	Aluminium and Copper	<u>Iron</u> and Paper
(4)	Aluminium and Steel	<u>Iron</u> and Glass

26. Jimmy set up an experiment. He filled two identical beakers with 100 ml of water at room temperature and heated them as shown below. The size of the flame of the three bunsen burners were kept the same.

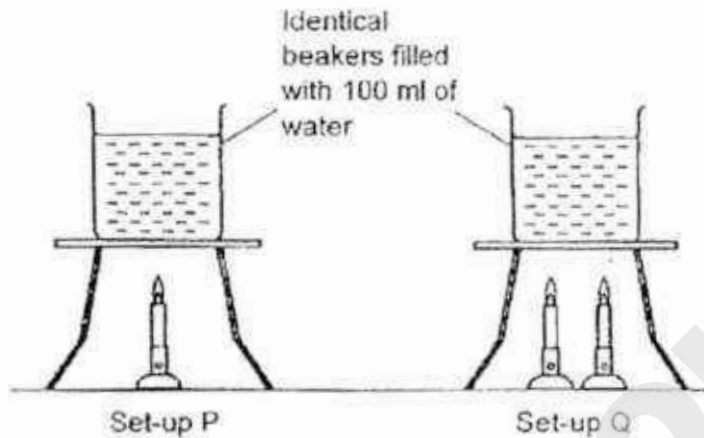

Jimmy measured the temperature of the water in both beakers at the start of the experiment.

Which graph correctly shows how the temperature of both beakers changed?

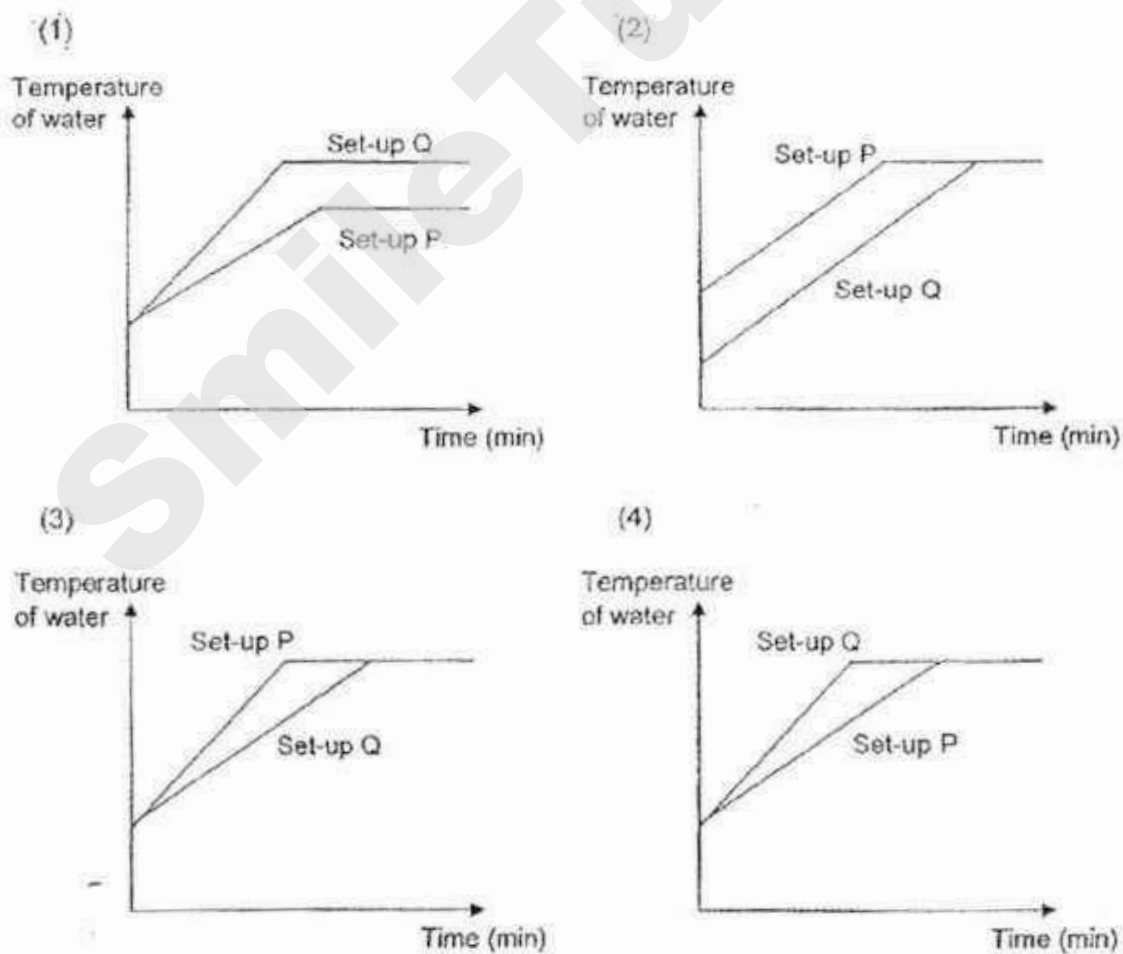

27. Sam poured different amount of water at 80°C into three cups of similar size.



A: Metal Cup with 100 ml of water

B: Metal Cup with 50 ml of water

C: Plastic Cup with 100 ml of water

Arrange the cups according to the amount of heat in the water after ten minutes, from the least amount of heat to the most amount of heat.

- (1) A, B, C
- (2) B, C, A
- (3) B, A, C
- (4) C, A, B

28. Mrs Lim placed the following set-up in a basin of ice.

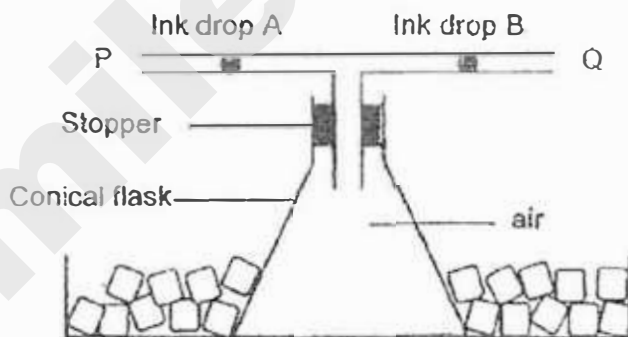

After ten minutes, ink drops A and B will move towards _____

- (1) P
- (2) Q
- (3) each other
- (4) towards P and Q respectively

SEMESTRAL ASSESSMENT 1 – 2017
PRIMARY 5

SCIENCE
BOOKLET B

13 Open-ended questions (44 marks)

Total Time for Booklets A and B : 1 hour 45 minutes

INSTRUCTIONS TO CANDIDATES

1. Write your name and index number in the space provided.
2. Do not turn over the page until you are told to do so.
3. Follow all instructions carefully.
4. Answer all questions.
5. Write your answers in this booklet.

Marks Obtained

Section B

	/ 44
--	------

Name: _____ () Class: P 5 _____

Date : 3 May 2017

Parent's Signature: _____

Section B: (44 marks)

Write your answers to questions 29 to 41.

The number of marks available is shown in brackets [] at the end of each question or part question.

29. Study the table below carefully.

	Has part X	Has part Y
Plant cell	Yes	Yes
Animal cell	No	Yes

(a) If both cells have nuclei, identify part X and Y. [1]

Part X: _____

Part Y: _____

(b) The skeleton of an animal supports its body and gives it its shape. Which part of the plant cell performs this same function? [1]

Score	2
-------	---

30. The diagram below shows the African Tulip and the Pea.

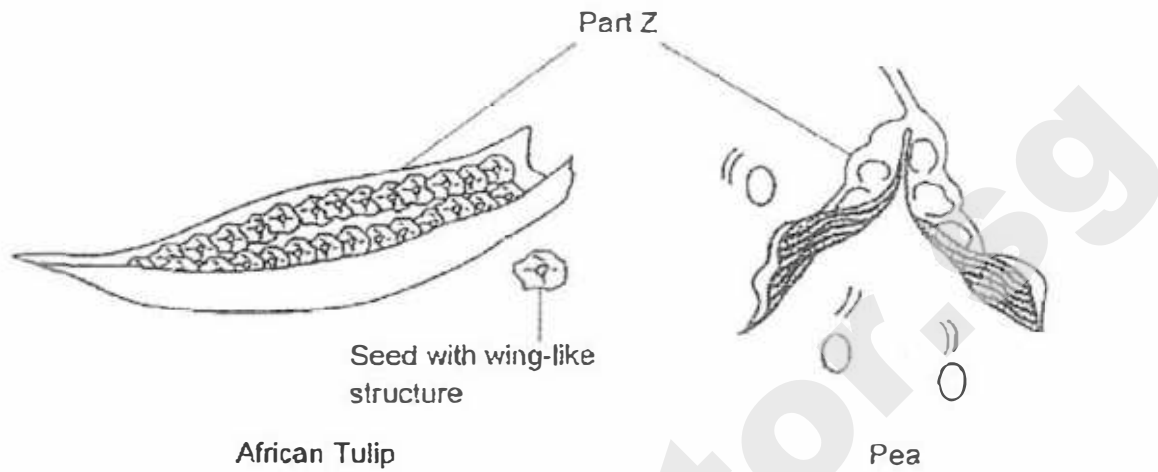

- (a) Based on your observations, which seeds will be dispersed further? Explain your answer. [2]

- (b) Part Z is found to be dry and thin in the African Tulip and Pea. Which part of the flower is Part Z before fertilisation took place? [1]

Score	3
-------	---

31. The diagram below shows a sperm cell and an egg cell.

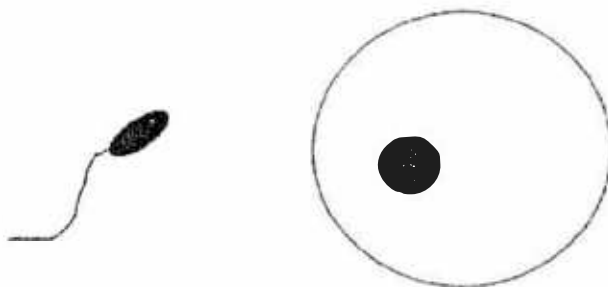

- (a) What must happen between the sperm and the egg in order for fertilisation to happen? [1]

- (b) Children often have similar traits with their parents. Which cell part in the sperm and egg is responsible for this? [1]

- (c) State a function of the cell part mentioned in (b). [1]

Score	3
-------	---

32. Tom set up the apparatus as shown below.

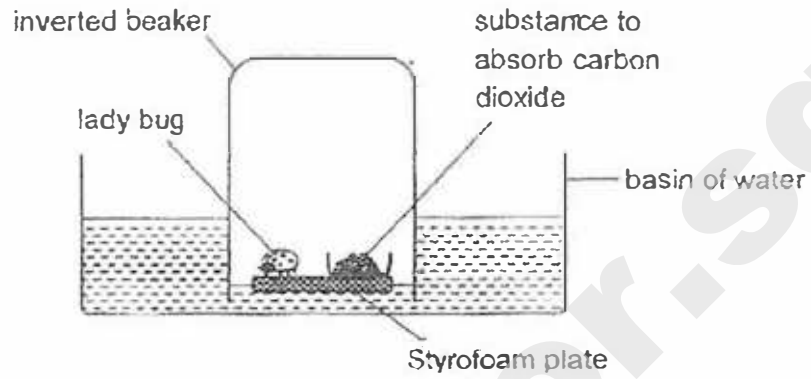

(a) What would happen to the water level in the inverted beaker after one hour? [1]

(b) How did the lady bug cause the change in the water level in the beaker in part (a) above? [2]

Score	3
-------	---

33. Study the flow chart below carefully.

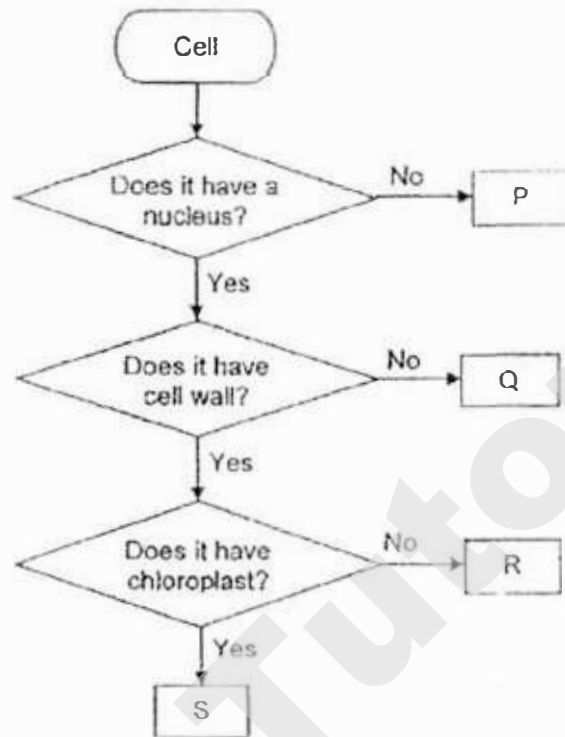

(a) Match P, Q, R or S to the appropriate blanks below. [1]

(i) Leaf cell: _____

(ii) Root cell: _____

(b) Explain your answer in part (a). [1]

Score	2
-------	---

34. The diagram below shows the dispersal patterns of Plant A and Plant B

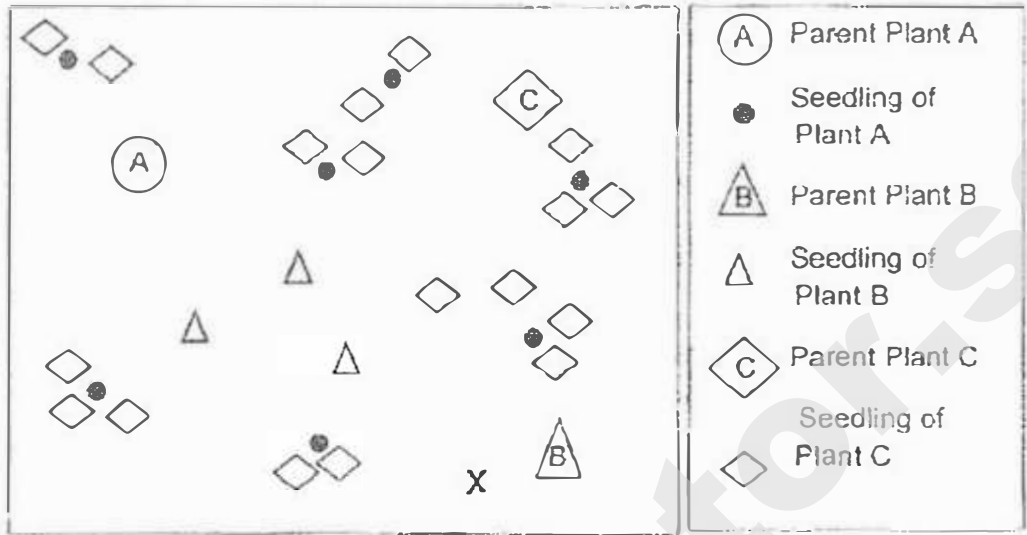

(a) State the dispersal method of Plant A and Plant C. [1]

i. _____ dispersal

ii. _____ dispersal

(b) It is observed that the seedlings of Plant A did not grow well even though they are dispersed far away from their parent and each other. State a possible reason. [2]

(c) Plant B is dispersed by the wind. Draw an arrow starting from point X in the diagram above to indicate the direction of the wind. [1]

Score	4
-------	---

35. Cross-pollination happens when a flower is pollinated by pollen grains from another flower of a plant. A farmer wants to prevent cross-pollination to happen in his farm. He grows Type D tomatoes and Type E tomatoes. The table below shows the flowers of these tomato plants.

Flower of Type D tomato plant	Flower of Type E tomato plant
<ul style="list-style-type: none"> • Orange in colour • Sweet-smelling • Blooms in April 	<ul style="list-style-type: none"> • Yellow in colour • Sweet-smelling • Blooms in July

- (a) How are pollen grains from the anthers transferred to the stigma of the flower? Explain your answer. [2]

- (b) Explain why cross-pollination between these two types of flowers cannot take place in the farm? [1]

- (c) Anther is the part of the flower that produces male reproductive cells in pollen grains. Which part in the human produces male reproductive cells? [1]

- (d) The following diagram shows the male reproductive system in human. Mark a cross to indicate the part mentioned in (c). [1]



Score	5
-------	---

36. Dan placed two identical plants into two identical jars, each containing water at the same level as shown below. The roots of the plant in Set-up B had been tightly wrapped with a plastic bag. He placed both set-ups under the sun for an hour.

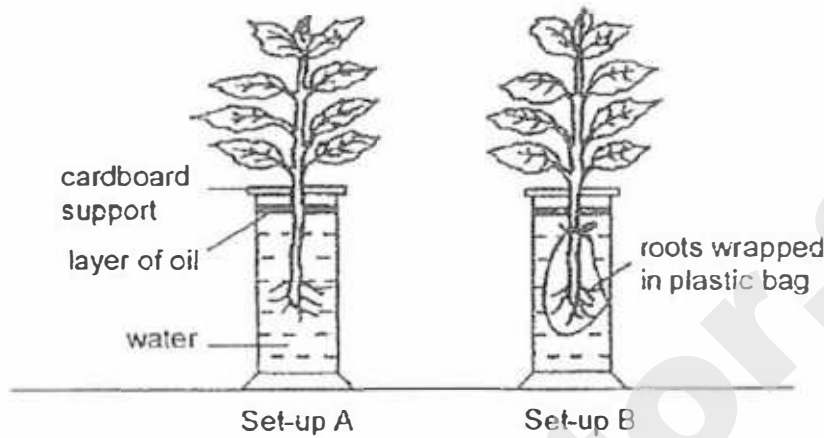

- (a) At the end of the experiment, Dan measured the height of water left in each jar. He found the height of water in Set-up A to be 85 mm. Complete the table to show the possible result for Set-up B. [1]

	Height of water at first (mm)	Height of water after 1 hour (mm)
Set-up A	200	85
Set-up B	200	

- (b) Explain the purpose of the layer of oil in the jars. [2]

- (c) Explain clearly why the water in set-up A was lower. [1]

Score	4
-------	---

37. The picture below shows a plastic water bottle that we bring outdoors.



(a) Name two properties and explain why plastic is a better material for making Part X instead of glass? [2]

i) _____

ii) _____

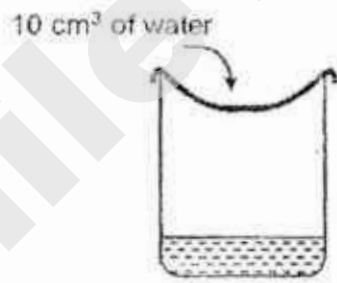

A piece of fabric is placed over a beaker as shown in the diagram above. 10 cm³ of water is poured into the beaker through the fabric. The amount of water collected in the beaker using three different fabric, A, B and C, is measured and recorded in the table below.

Fabric	A	B	C
Amount of water collected in the beaker (cm ³)	9	6	8

- (b) Which fabric is most suitable to make a bath towel? Explain your answer using the results in the table. [2]

- (c) Name two factors about the three fabric used that need to be kept constant to ensure a fair test. [1]

Score	5
-------	---

38. An investigation was carried out using the same batteries, iron rods and paper clips. The results of the investigation are shown below.

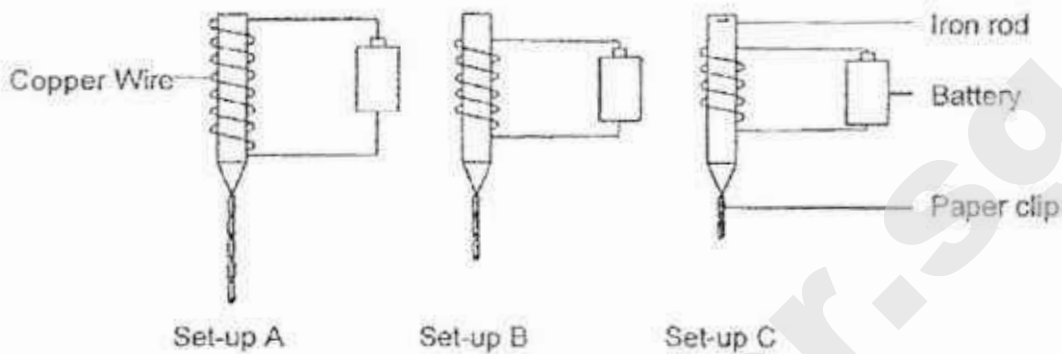

- (a) Identify the following variables of the above experiment. [1]

Dependent (measured) variable: _____

Independent (changed) variable: _____

- (b) Explain why set-up A attracted the most number of clips. [1]

- (c) Besides adding more coils around the rod, what is another method that can increase the number of paper clips attracted? [1]

- (d) Peter replaced the iron rod with a copper rod. Would the rod still be able to attract the paper clips? State a reason. [1]

Score	4
-------	---

39. Tommy kept some water boiling in an electric kettle. He brought a metal plate at room temperature to the spout of the kettle as shown below. He collected and measured the amount of water that dripped from the metal plate for one minute.

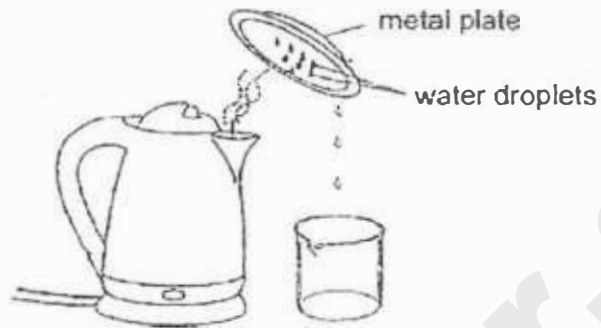

- (a) Explain clearly how the water droplets are formed on the metal plate. [2]

Tommy repeated the experiment above with another metal plate taken from the refrigerator.

- (b) Would Tommy collect more or less water in the beaker in one minute? Explain your answer. [1]

- (c) While observing the water dripping into the beaker from both metal plates, Tommy noticed that less water droplets fell into the beaker nearer to the end of the observation.

What could be the reason for this? [2]

40. Containers in set-ups A, B and C are of the same size and thickness but made of different materials. The containers were filled with the same volume of water at 70°C and left on a table.

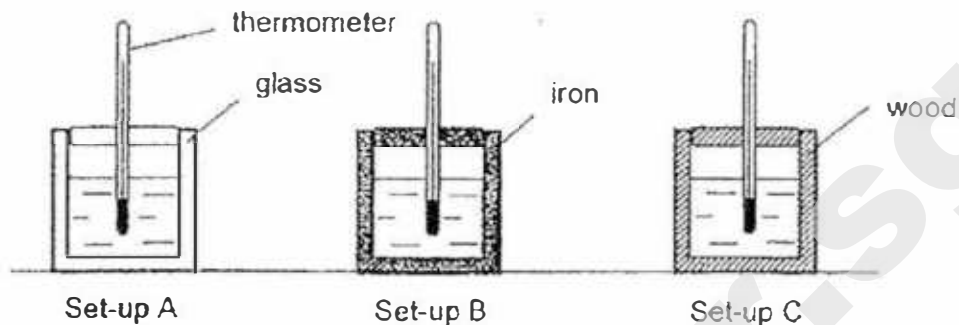

The graph below shows the temperature of water in set-ups A, B and C over a period of time

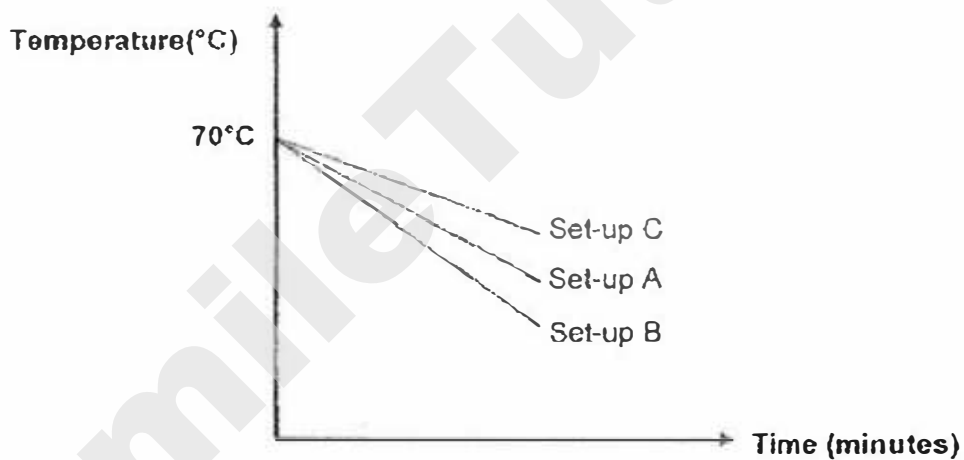

- (a) Based on the graph, which material (glass, iron or wood) is the poorest conductor of heat? Explain your answer. [2]

Tom prepared two identical cups of ice water. He used a metal spoon for one cup and a wooden spoon for another. When he touched the spoons, he realised that the metal spoon felt much colder than the wooden spoon.

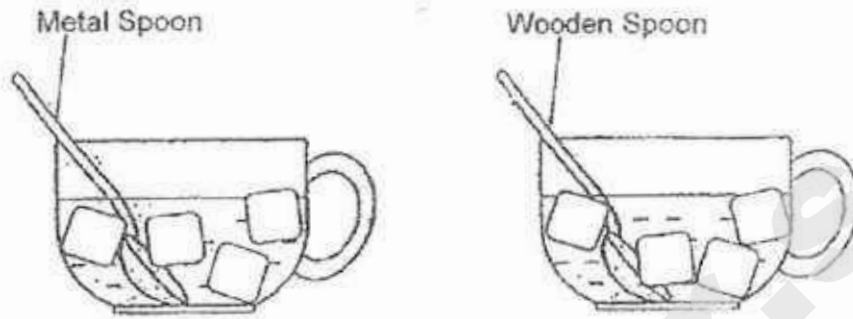

(b) Explain why the metal spoon felt much colder than the wooden spoon. [2]

End of Paper

Score	4
-------	---

EXAM PAPER 2017 (P5)

SCHOOL : Nan Hua

SUBJECT : SCIENCE

TERM : SA1

Q1	Q2	Q3	Q4	Q5	Q6	Q7	Q8	Q9	Q10
4	1	1	3	3	2	4	4	4	4
Q11	Q12	Q13	Q14	Q15	Q16	Q17	Q18	Q19	Q20
3	1	3	2	4	4	2	2	1	2
Q21	Q22	Q23	Q24	Q25	Q26	Q27	Q28		
2	2	1	2	2	4	3	3		

29)a)Part X:cell wall

Part Y:cell membrane

b)cell wall

30)a)The African Tulip will be dispersed further, because it's seed has a seed with wing-like structure that can kept it on the air longer than the Pea.

b)ovary

31)a)The sperm must fuse with the egg in order for fertilization to occur.

b)Nucleus

c)It contains genetic information from both parents.

32)a)The water level will increase

b) When the lady bug respired, it took in oxygen and gave out carbon dioxide. The carbon dioxide is absorbed by the substance causing the amount of air in the inverted beaker to decrease. The water will then occupy the space of the carbon dioxide.

33)a)i) Leaf cell: S

ii) Root cell: R

b) The leaf cell has chloroplast which contain chlorophyll to trap sunlight to photosynthesis but the root cell does not have chloroplast as it does not photosynthesis.

34)a)i) animal

ii) animal

b) As Plant A and C grow in the same area, Plant A has to compete with Plant C for space, water, light.

c)

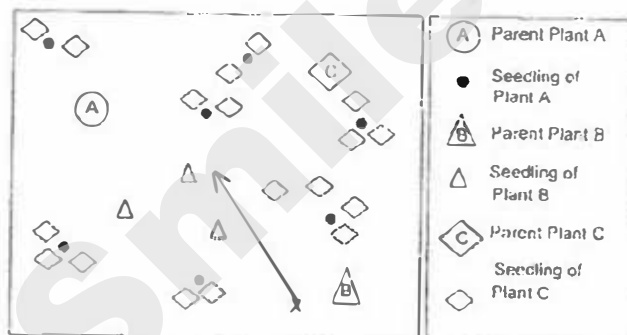

35)a) When the insect comes to find nectar, the pollen grain will stick onto the insect's body and it will land onto the stigma.

b) The flowers of the two types of tomatoes flower at different times.

c) Testes

d)



36)a)200

b)The purpose of the layer of oil is to prevent evaporation to occur and to ensure the water taken in is by the plants.

c)Set up A had taken in water by the roots.

37)a)i)Plastic is lighter so it will be easier to carry around.

ii)Plastic is stronger so that the bottle will not break when dropped.

b)Fabric B.It has the most amount of water collected in the beaker which shows it is most absorbent fabric.

c)size and thickness of the fabric.

38)a)Dependent variable:number of paper clips attracted

Independent variable:number of coils of copper wire

b)In set-up A the number of coils around the iron rod is the highest,the resulting in the strongest magnetic.

c)Put in more batteries

d)No.Copper is non-magnetic material and cannot be magneticed.

39)a)The steam lost heat to the cooler surface of the plate and condense into water droplets.

b)More water will collected as the metal plate is colder.Steam will lose heat faster due to the greater temperature difference and speed up the rate of condensation.

c)The metal plate had gained heat from the steam and become hotter.This caused the temperature difference between the metal plates and steam to decrease resulting in a decrease in the rate of condensation.

40)a)Wood.The set-up with wood has the temperature of the water is the highest at the end so that the water loses heat to the surrounding the slowest.

b)The metal spoon is a better conductor of heat.Tom lost heat to the spoon and then the ice water faster.

SmileTutor.sg

PRIMARY 5 SCIENCE
SEMESTRAL ASSESSMENT 1
2017

BOOKLET A

Date : 8 May 2017

Duration : 1 h 45 min

Name : _____ ()

Class: Primary 5 ()

**DO NOT OPEN THIS BOOKLET UNTIL YOU ARE TOLD TO DO SO.
FOLLOW ALL INSTRUCTIONS CAREFULLY.**

Booklet A consists of 23 printed pages including this cover page.

Section A (28 x 2 marks = 56 marks)

For each question from 1 to 28, four options are given. One of them is the correct answer. Make your choice (1, 2, 3 or 4). Shade the correct oval (1, 2, 3 or 4) on the Optical Answer Sheet provided.

1. Which one of the following plants reproduces by spores?



(1) Bird's nest fern



(2) Hibiscus plant



(3) Orchid plant



(4) Ixora plant

2. For an adult flowering plant to produce seeds, which process(es) must take place?

- (1) Pollination only
- (2) Germination only
- (3) Pollination and fertilisation
- (4) Pollination and germination

3. Study the flowchart below carefully.

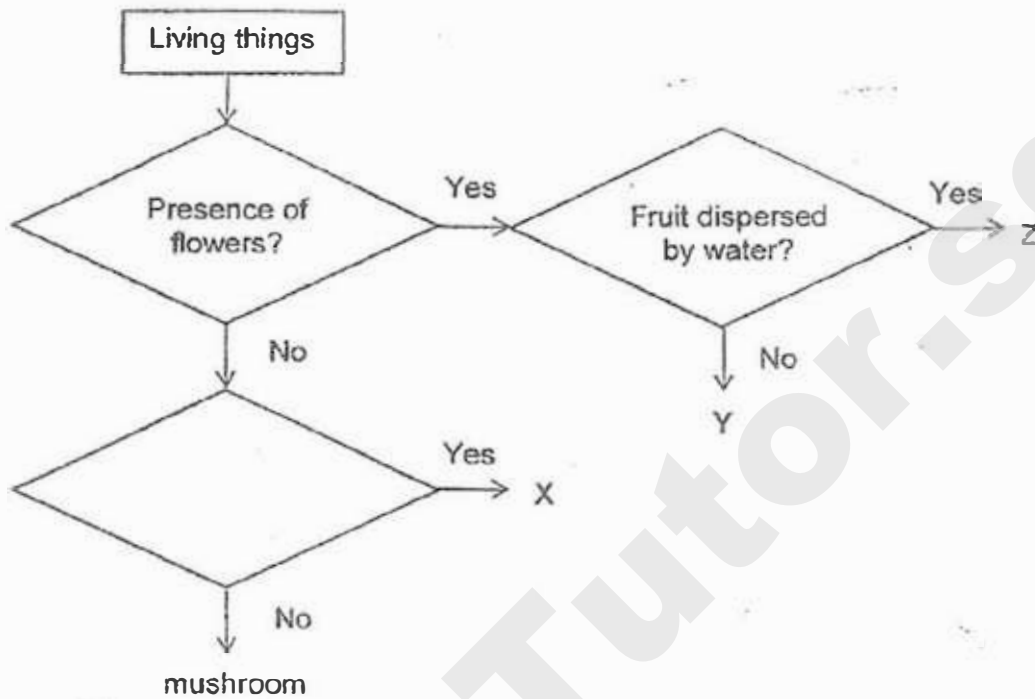

Which of the following could represent X, Y and Z?

	X	Y	Z
(1)	bird's nest fern	papaya plant	coconut
(2)	coconut	papaya plant	bird's nest fern
(3)	bird's nest fern	coconut	papaya plant
(4)	coconut	bird's nest fern	papaya plant

4. Irene planted Plant V on a plot of land. She noticed that the plants were not growing well. Her friend, Carina, commented that the presence of weeds has affected the growth of Plant V.

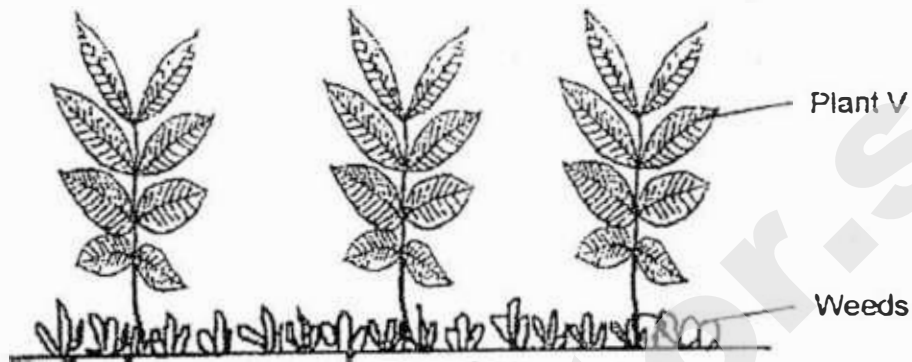

Which of the following explains why plant V is not growing well?

- A There is not enough air for Plant V.
- B There is not enough food for Plant V.
- C There is not enough space for Plant V.

- (1) C only
- (2) A and C only
- (3) B and C only
- (4) A, B and C

5. The diagrams below show the parts of two flowers, G and H, from different plants.

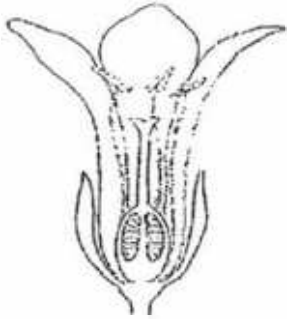

Flower G

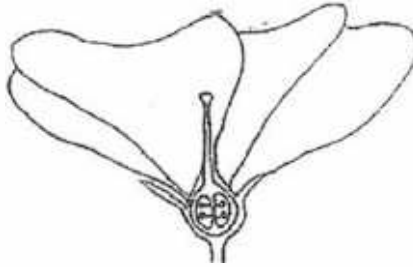

Flower H

Based on the diagrams, which of the following statements are correct?

- A Flower G can pollinate itself.
- B Only Flower H can develop into a fruit.
- C Both flowers can develop into fruits after fertilisation.
- D Both flowers can produce both male and female reproductive cells.

- (1) A and C only
- (2) B and D only
- (3) A, C and D only
- (4) A, B and D only

6. The diagram below shows a flower of a plant.

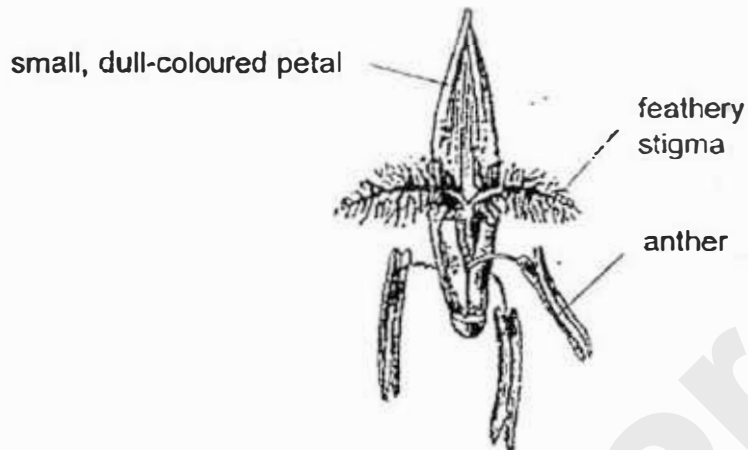

Based only on this diagram, which of the following best describes the way in which the flower is most likely pollinated?

- (1) The feathery stigma can capture pollen floating in the air.
 - (2) The feathery stigma will be carried by the wind to the anther.
 - (3) The petals are dull-coloured to attract insects for pollination.
 - (4) The flower produces a sweet scent to attract insects for pollination.
7. The diagram below shows a fruit that had been cut into half.

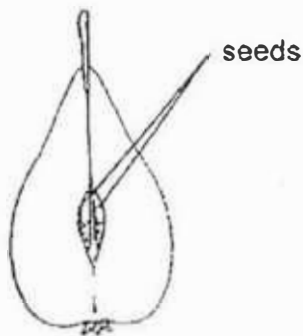

Based only on this diagram which one of the following statements is definitely true about the flower from which the fruit is developed from?

- (1) The fruit developed from a male flower.
- (2) There are at least two ovules present in the ovary.
- (3) The flower has brightly coloured petals to attract animals.
- (4) The stigma hangs out of the petals to capture pollen grains.

8. The diagram below shows the fruits of three different types of plants, X, Y and Z.

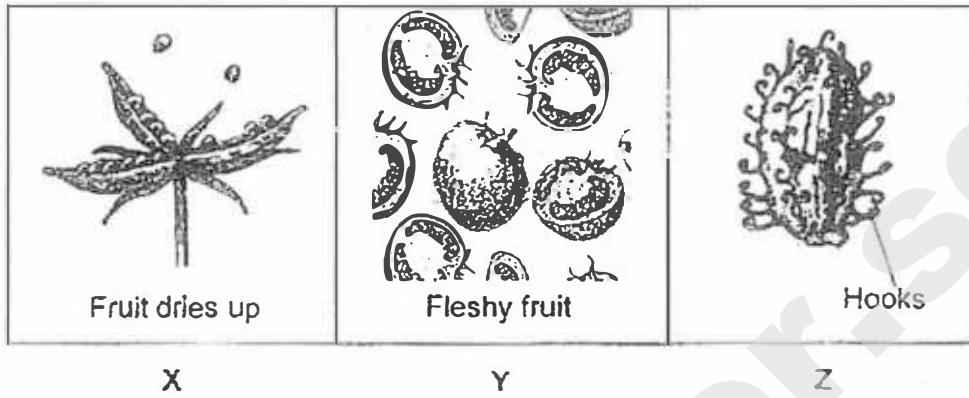

After three years, Karen observed the dispersal pattern of each plant. She recorded her observations as shown below.

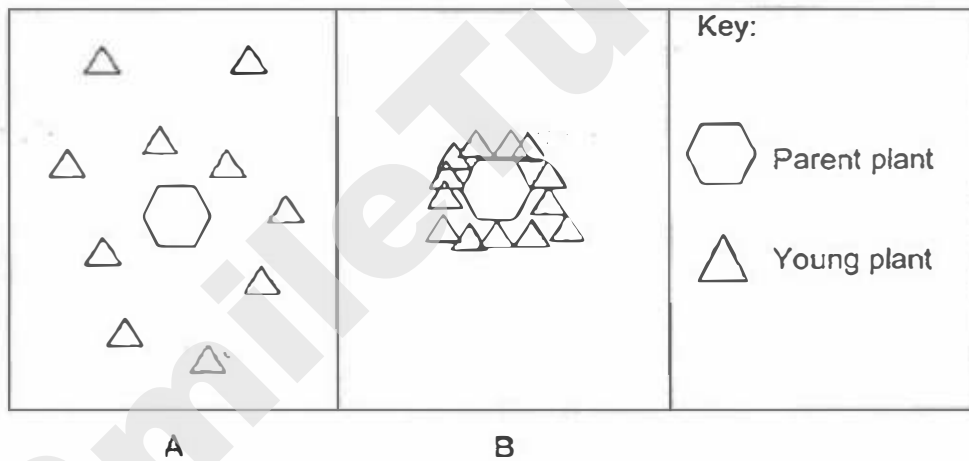

Which one of the following correctly matches the dispersal pattern of the seeds to their parent plants?

	A	B
(1)	Y	X and Z
(2)	X and Y	Z
(3)	X and Z	Y
(4)	Y and Z	X

9. Emily carried out an experiment to find out how the length of the wing-like structure of a shorea fruit affects the distance travelled by it. The shorea fruit was released in front of an electric fan as shown below.

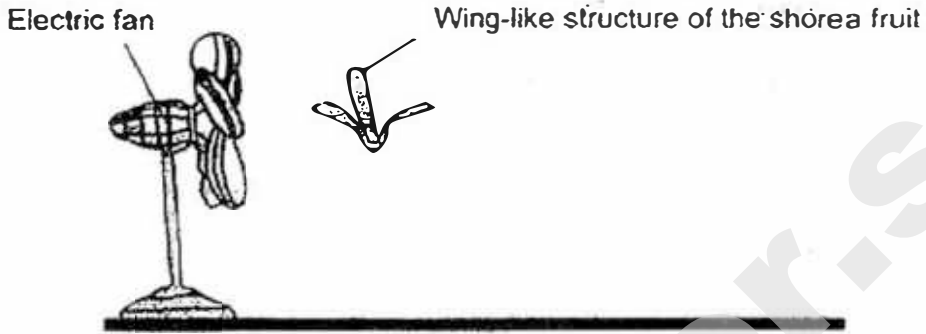

Which of the following graphs shows the most likely relationship between the length of the wing-like structure of the shorea fruit and the distance travelled by it?

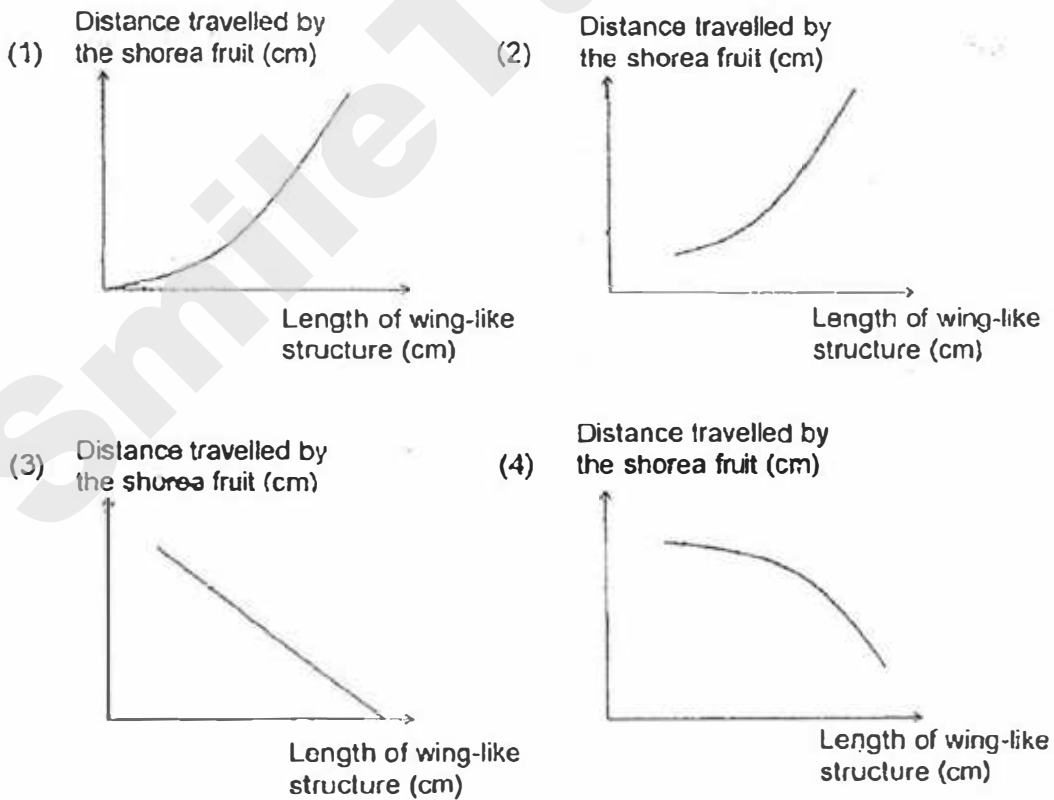

10. Megan set up the following experiment using green bean seeds.

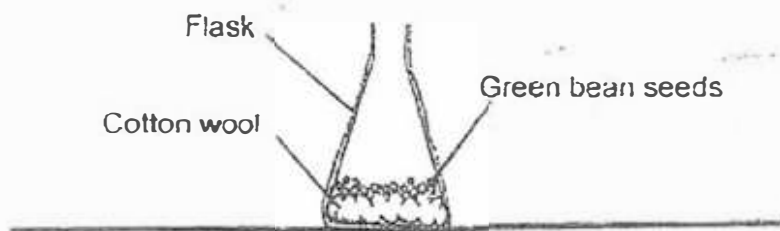

Which of the following conditions should she choose in order to have the thinnest and tallest seedlings at the end of her experiment?

	Location	Type of cotton wool	Number of green bean seeds
(1)	in a dark cupboard	dry	40
(2)	in the garden	moist	5
(3)	in the refrigerator	dry	5
(4)	near the window	moist	40

11. Gary observed a seed developing into a seedling over eight days as shown below. He then made a comparison between the mass of the seed leaves and the shoot.

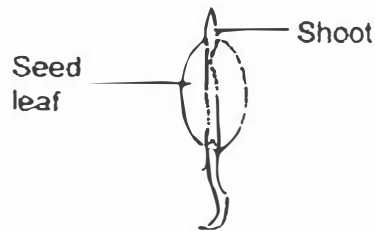

Which of the following graphs most likely shows the result of his experiment?

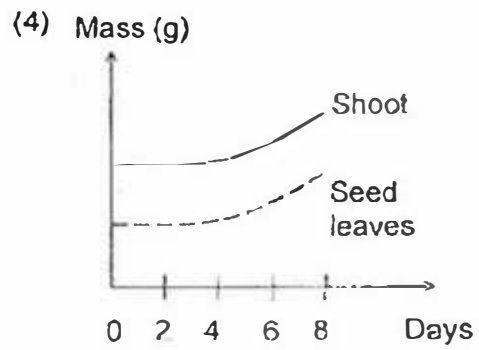
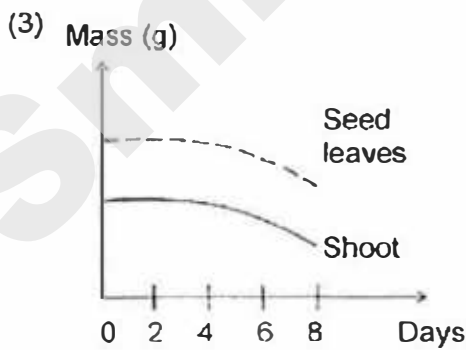
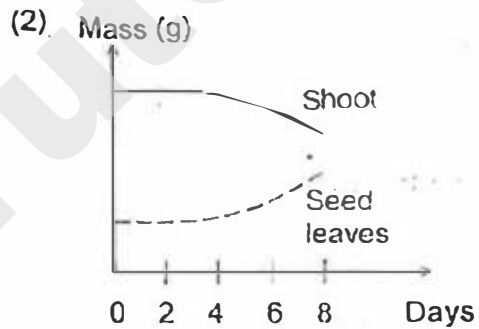
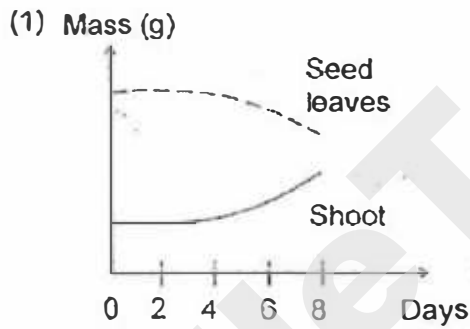

12. The diagram below shows the female human reproductive system.

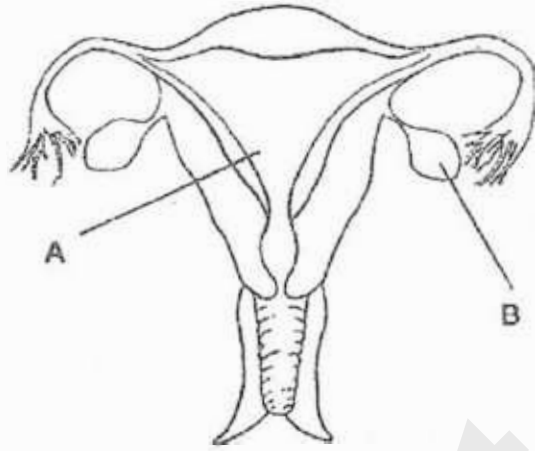

Which of the following correctly identify parts A and B?

	A	B
(1)	womb	egg
(2)	womb	ovary
(3)	egg	womb
(4)	ovary	womb

13. The diagram below shows Shinee's family tree.

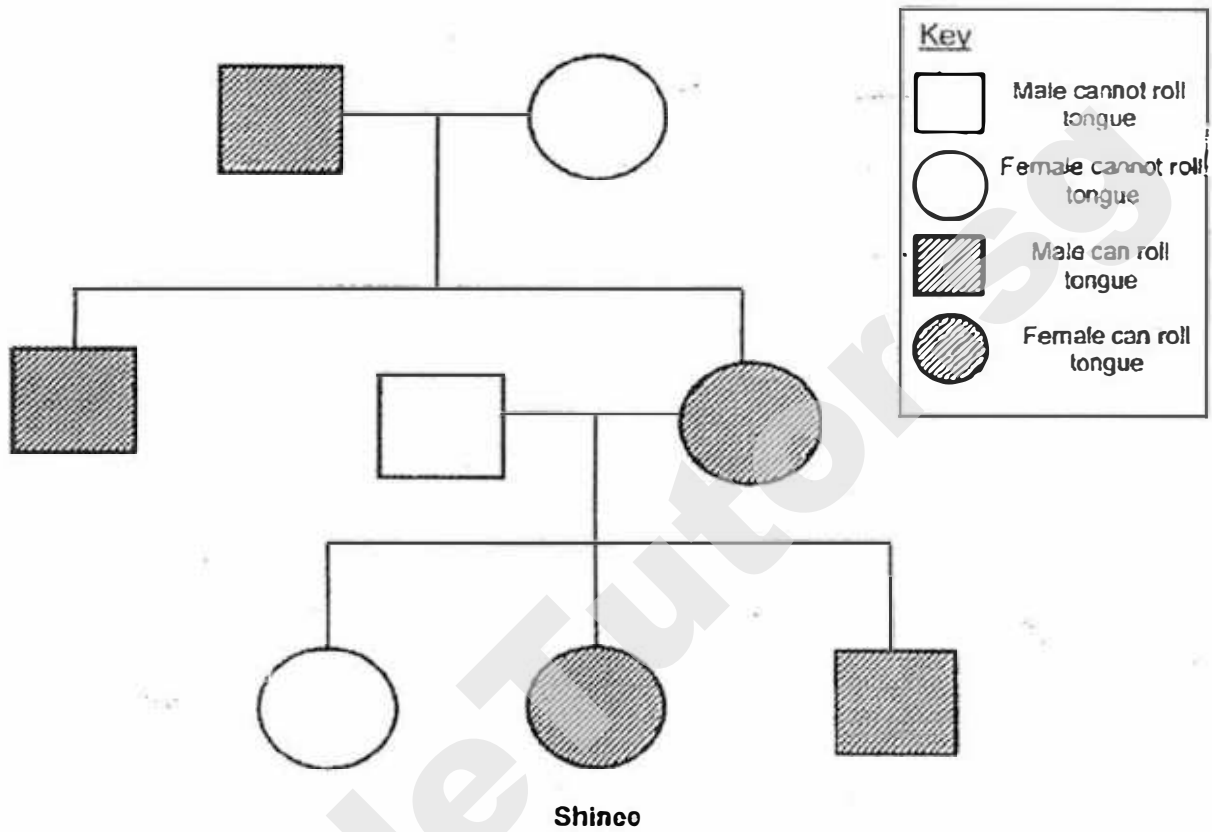

Based on the family tree, which one of the following statements is true?

- (1) Shinee's brother cannot roll his tongue.
- (2) Both Shinee's grandparents can roll their tongues.
- (3) Everyone in Shinee's family can roll their tongues.
- (4) Shinee inherited her ability to roll her tongue from her mother.

14. Study the flow chart below.

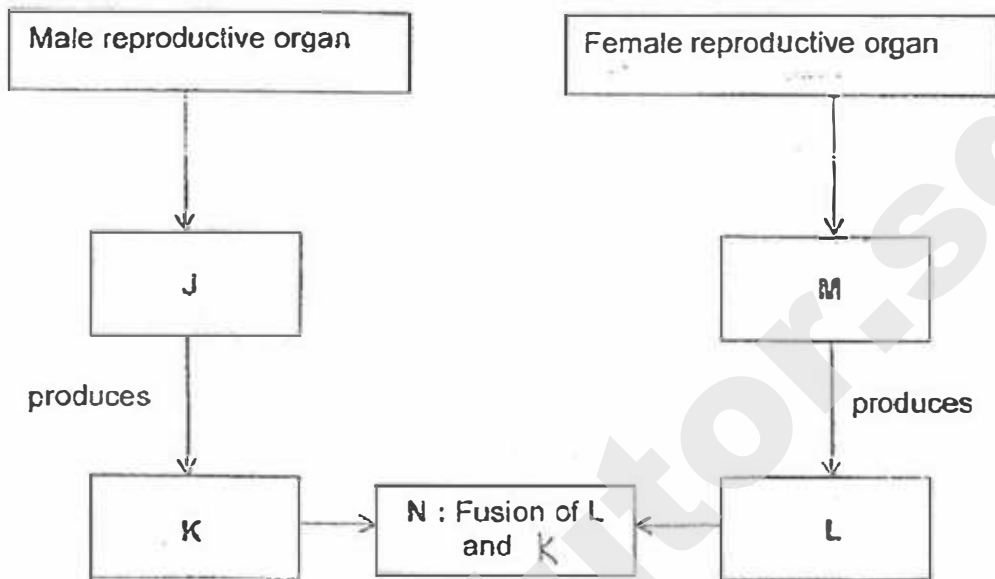

Which of the following could represent J; K, L, M and N?

	J	K	L	M	N
(1)	sperms	testis	ovary	eggs	fertilisation
(2)	testis	sperms	eggs	ovary	fertilisation
(3)	penis	sperms	ovary	eggs	fertilisation
(4)	sperms	penis	eggs	ovary	reproduction

15. A beaker of iced water was left on the table in a room.

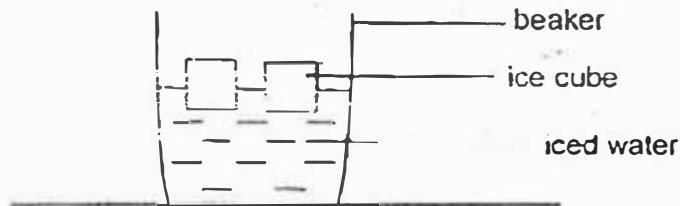

Which of the following observations after 1 hour are correct?

- A The water level in the beaker will increase.
- B Water droplets will be formed on the inner side of the beaker.
- C The temperature of the ice remains at 0°C until all the ice has melted.
- D Formation of the water droplets is due to the condensation of water vapour on the cold outer surface of the beaker.

- | | |
|---------------------|-------------------|
| (1) A and D only | (2) B and C only |
| (3) A, C and D only | (4) A, B, C and D |

16. Which of the following activities are ways to help in conserving water?

- A Take a shorter shower.
- B Use full flush to flush the toilet.
- C Use an energy-efficient refrigerator.
- D Turn off the tap while soaping the dishes.

- | | |
|---------------------|---------------------|
| (1) A and D only | (2) B and C only |
| (3) A, B and D only | (4) A, C and D only |

17. Which one of the following diagrams correctly represents the water cycle?

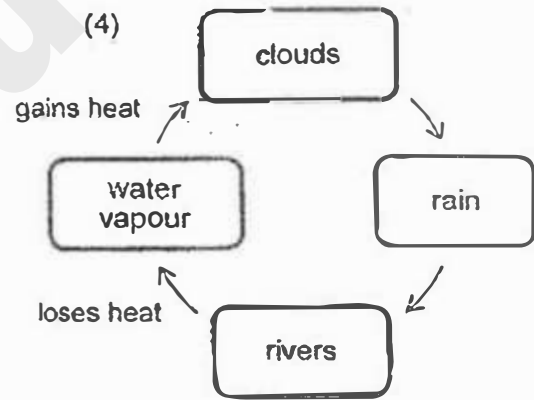
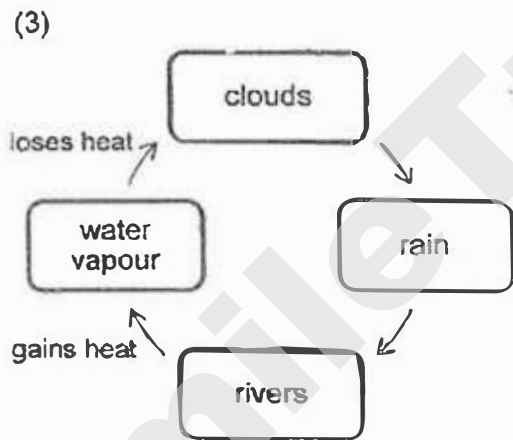
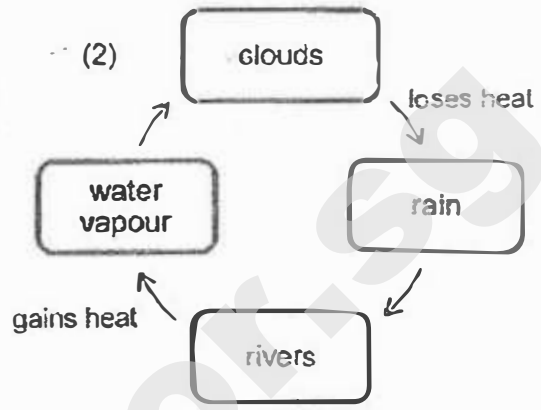
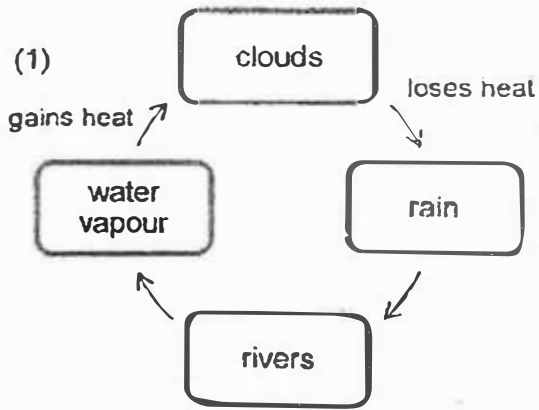

18. Ji Sub was conducting an experiment to find out how the temperature of the surroundings would affect the rate of evaporation of water. He placed one beaker in the classroom and the other beaker in the basketball court.

Which of the following variables must he keep the same in order for the experiment to be fair?

- A Temperature of surroundings
- B Amount of water in the beaker at first
- C Exposed surface area of the water in the beakers
- D Amount of water in the beaker at the end of the experiment

- (1) A and B only
- (2) A and D only
- (3) B and C only
- (4) B, C and D only

19. Four similar beakers, E, F, G and H, were each filled with 100ml of water at different temperatures. The beakers were placed in the same room at 28°C as shown in the diagram below.

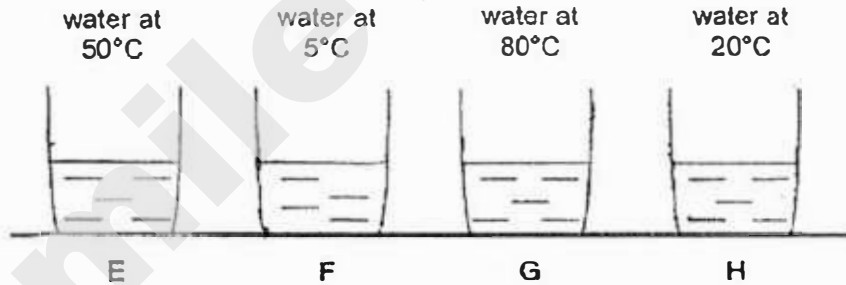

Which beakers would have water droplets forming on their outer surfaces after some time?

- (1) E and G only
- (2) F and H only
- (3) E, F and G only
- (4) F, G and H only

20. Minho heated some water in a beaker until it boiled. He continued to allow the water to boil for some time. The beaker of water was then left on a table to cool. He recorded his results in the graph as shown below.

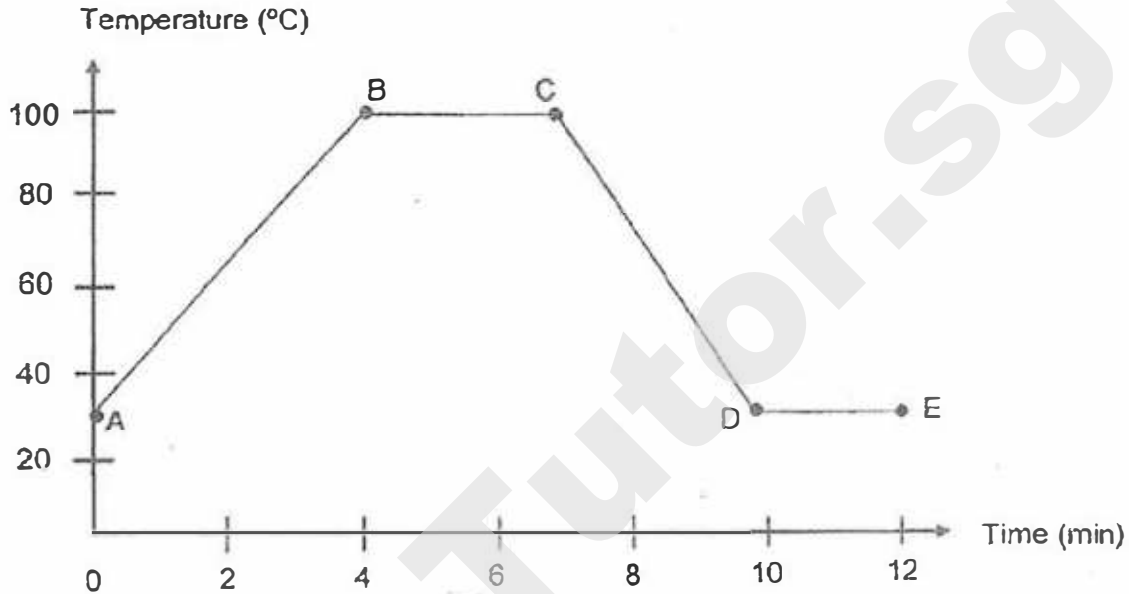

Which of the following statements below correctly explain what happened to the water at the different stages?

- A Heat was lost from C to D.
- B Evaporation took place from A to B only.
- C Water exists in two states between B and C.
- D The water had reached room temperature from D to E.

- | | |
|---------------------|---------------------|
| (1) B and C only | (2) A, B and D only |
| (3) A, C and D only | (4) A, B, C and D |

21. Fandi is planning to put up a shadow puppet performance. He placed the puppet between a torch and a screen as shown below.

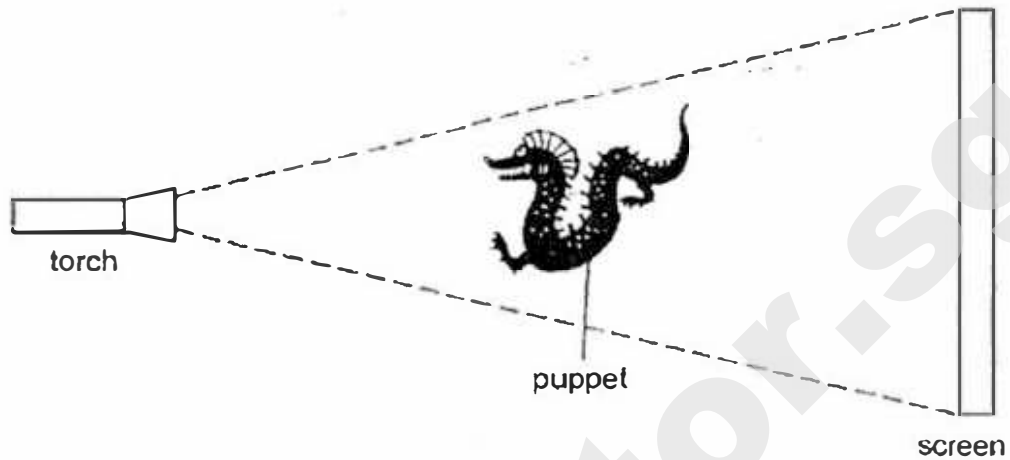

Fandi wants to get a bigger shadow of the puppet. Which of the following ways would allow him to get a bigger shadow?

- A Move the torch nearer to the puppet.
- B Move the torch further away from the puppet.
- C Move the puppet nearer to the screen.
- D Move the puppet further away from the screen.

- (1) A and C only
- (3) B and C only

- (2) A and D only
- (4) B and D only

22. Ravi looked into a mirror and saw his own reflection.

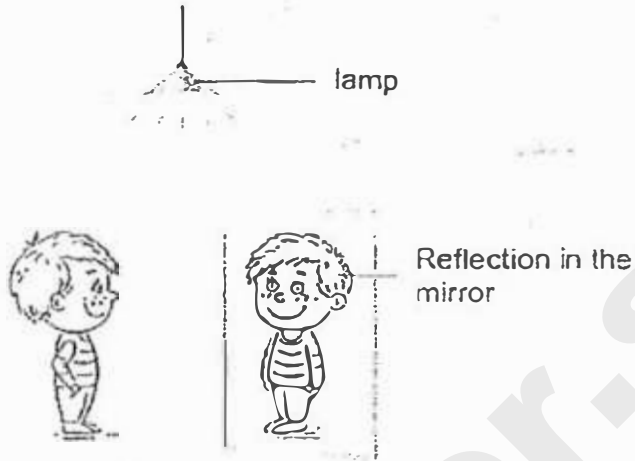

Which one of the following diagram shows the correct light ray to explain why Ravi could see his own reflection?

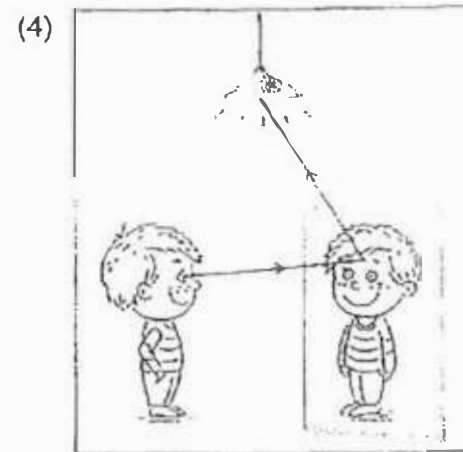
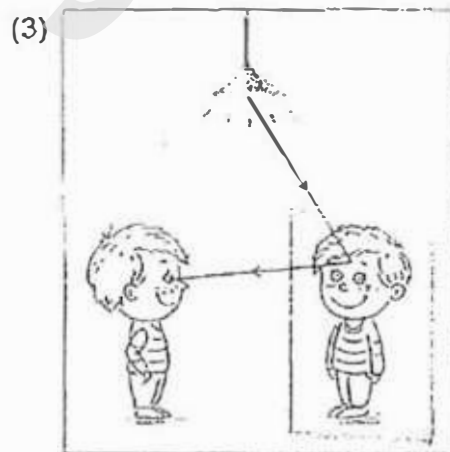
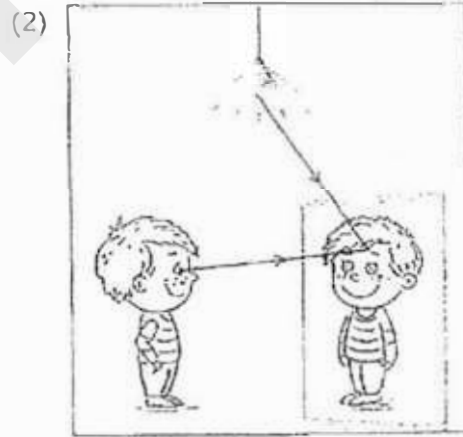
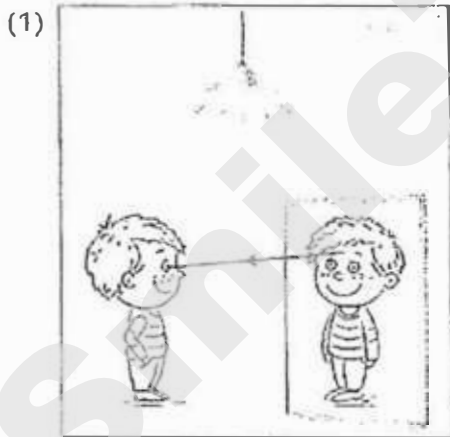
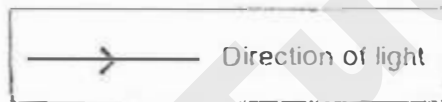

23. Sally had a pencil and ruler.

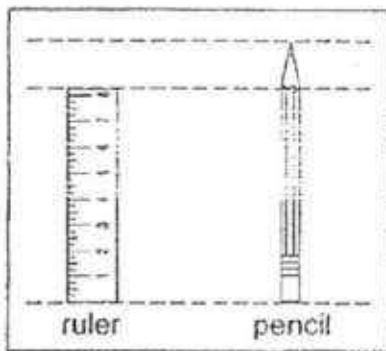

Front view

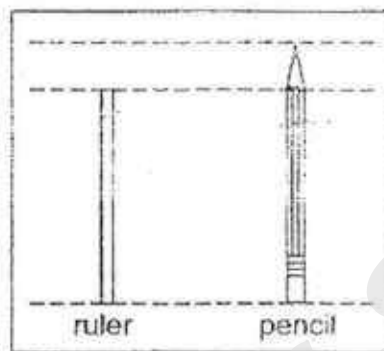

Side view

She placed the pencil and ruler between a torch and a screen as shown below. All the objects are arranged in a straight line.

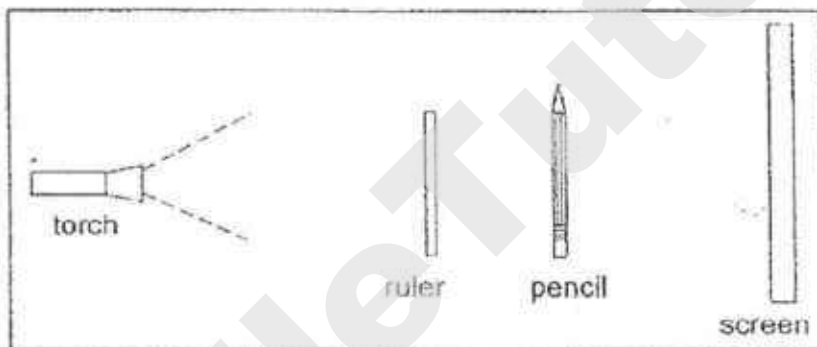

Side view of the set-up

Which of the following shadow would she most likely observe on the screen?

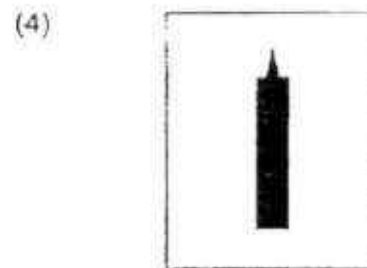
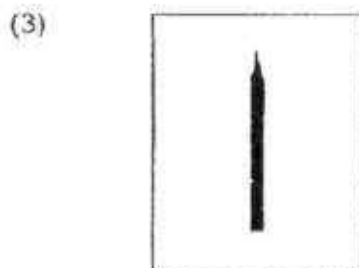

24. Eddie's grandmother knitted a wool cover for his water bottle which was made of metal. Eddie observed that the wool cover helped to keep the water in his water bottle warm for a longer period of time.



Water bottle



Wool cover

Which one of the following statements gives a correct explanation for his observation?

- (1) The metal reduces heat loss from the water to the wool.
 - (2) The wool reduces heat gain from the surrounding to the bottle.
 - (3) The metal makes the water gain heat faster from the surrounding.
 - (4) The air in the wool reduces heat loss from the water bottle to the surrounding.
25. Two cubes of the same size were left on the table at room temperature. One cube was made of metal and the other cube was made of plastic. After 30 minutes, Rajan touched both the metal cube and the plastic cube. He realised that the metal cube felt cooler than the plastic cube.

Which one of the following statements is true?

- (1) The metal cube felt cooler because it has a higher temperature than the plastic cube.
- (2) The metal cube felt cooler because it has a lower temperature than the plastic cube.
- (3) The metal cube felt cooler because it conducted heat away from Rajan's hand faster than the plastic cube.
- (4) The metal cube felt cooler because it conducted heat away from Rajan's hand slower than the plastic cube.

26. An experiment was set up using a pump which is connected to a glass container as shown below. The volume of the glass container is 300cm^3 and it contained 50cm^3 of water.

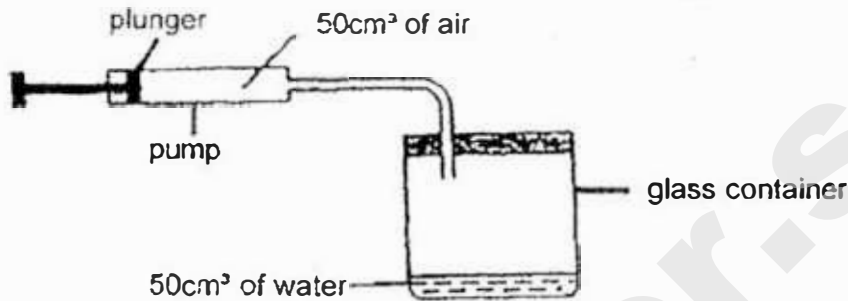

50cm^3 of air was added into the glass container by pushing the plunger. It was observed that the final volume of air in the container was 250cm^3 .

What is the reason for the above observation?

- (1) Air occupies space.
 - (2) Air has no definite volume.
 - (3) Liquid has no definite shape.
 - (4) Liquid has no definite volume.
27. Kumar has 2 objects, a 50 cent coin and a metal rod, as shown below.



50 cent coin



metal rod

Which of the following statements made by Kumar is false?

- (1) They are flexible.
- (2) They are waterproof.
- (3) They will not break when dropped.
- (4) They do not allow light to pass through.

28. Fairuz has a bar magnet. He wants to find out which is the North-South direction inside the classroom.

Which of the following is/are method(s) that he could use?

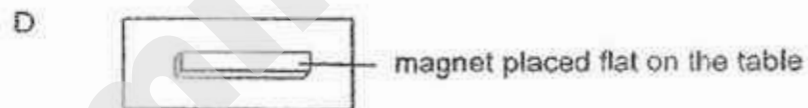
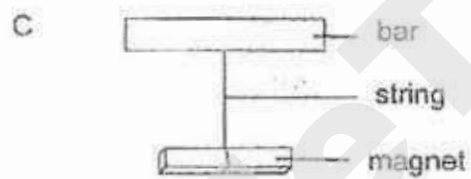
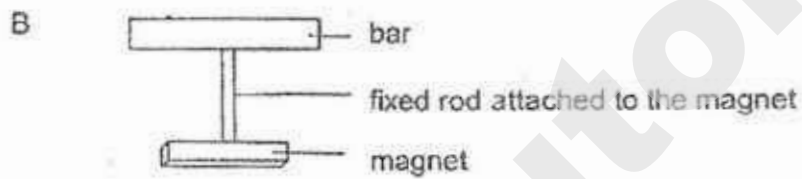
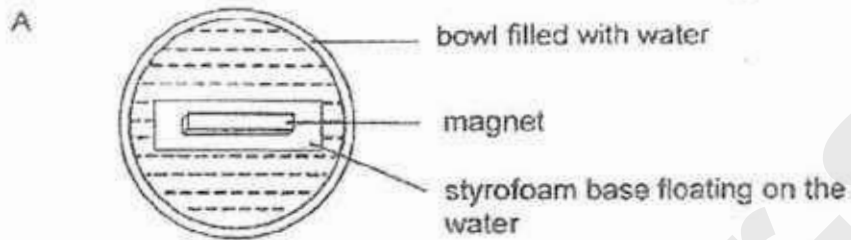

- (1) C only
(3) B and D only

- (2) A and C only
(4) A, B, C and D

PRIMARY 5 SCIENCE
SEMESTRAL ASSESSMENT 1
2017

BOOKLET

Date : 8 May 2017

Duration : 1 h 45 min

Name : _____ ()

Class: Primary 5 ()

Marks Scored:

Booklet A:		56
Booklet B :		44
Total :		100

Any query on marks awarded should be raised by 18 May 2017. We seek your understanding in this matter as any delay in the confirmation of marks will lead to delays in the generation of results.

Parent's signature:

**DO NOT OPEN THIS BOOKLET UNTIL YOU ARE TOLD TO DO SO.
FOLLOW ALL INSTRUCTIONS CAREFULLY.**

Booklet B consists of 16 printed pages including this cover page.

Section B (44 marks)

Write your answers to questions 29 to 41 in the spaces provided.

29. The diagram shows a section through the female parts of a flower.

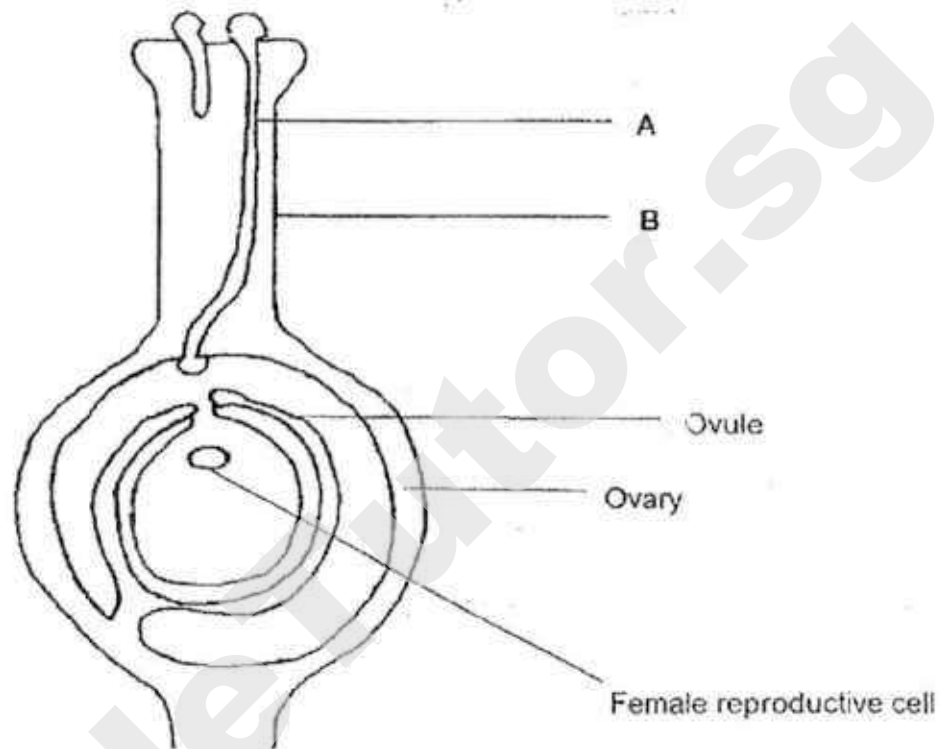

(a) Name parts A and B. [1]

A: _____ B: _____

(b) Describe what happens during fertilisation. [1]

(c) Based on the diagram above, explain how part A enables fertilisation to take place. [2]

30. Jasmine cut away two parts, A and B, of a flower shown below and observed it for a week. At the end of the week, she was surprised to see a fruit developing from the flower.

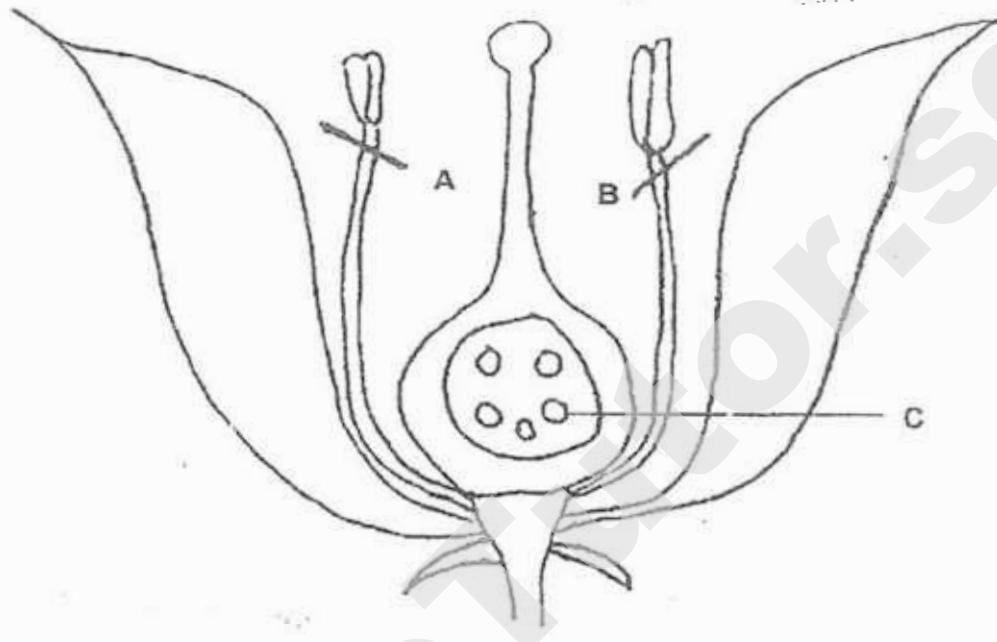

- (a) If no pollination had taken place before parts A and B were cut, explain why a fruit could develop from the flower? [2]

- (b) What would happen to part C when the fruit developed from the flower? [1]

31. The graph below shows the number of seeds of Plant X and Y dispersed by wind.

Number of seeds dispersed

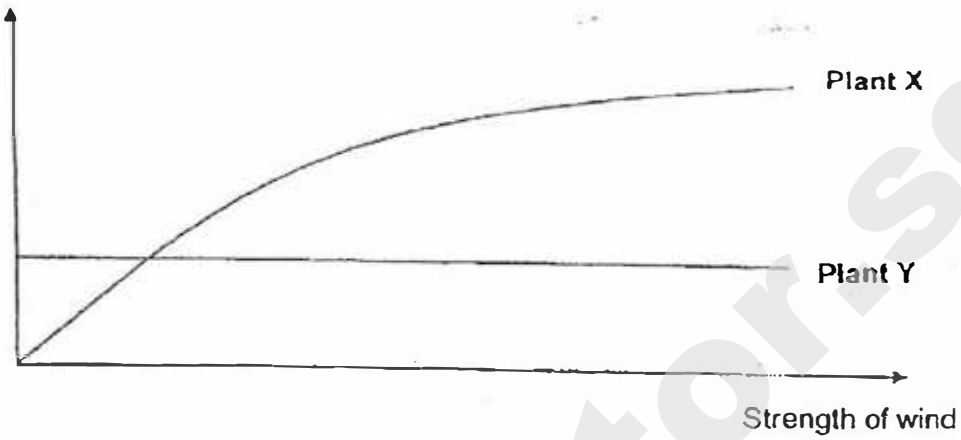

- (a) Give an example of Plant X. [1]

- (b) Based on the graph above, give the reason why Plant Y is not likely to be dispersed by wind. [1]

32. Alice set up an experiment to compare the growth of seeds from plants X and Y. The set-ups were put in her room by the window for 15 days as shown below.

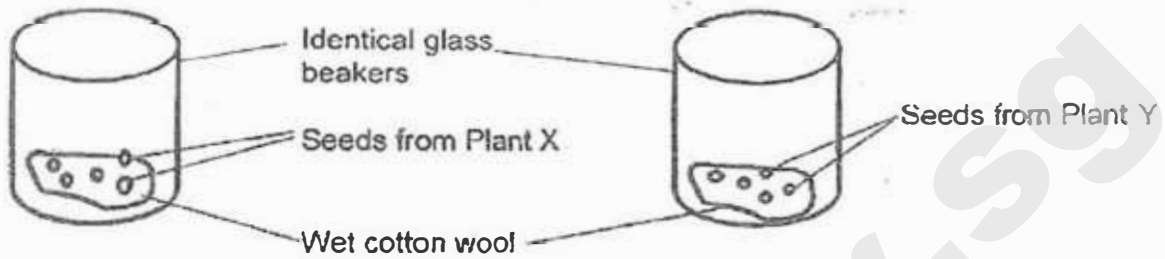

She then recorded the changes in the average height of the seedlings over seven days in the graph shown below.

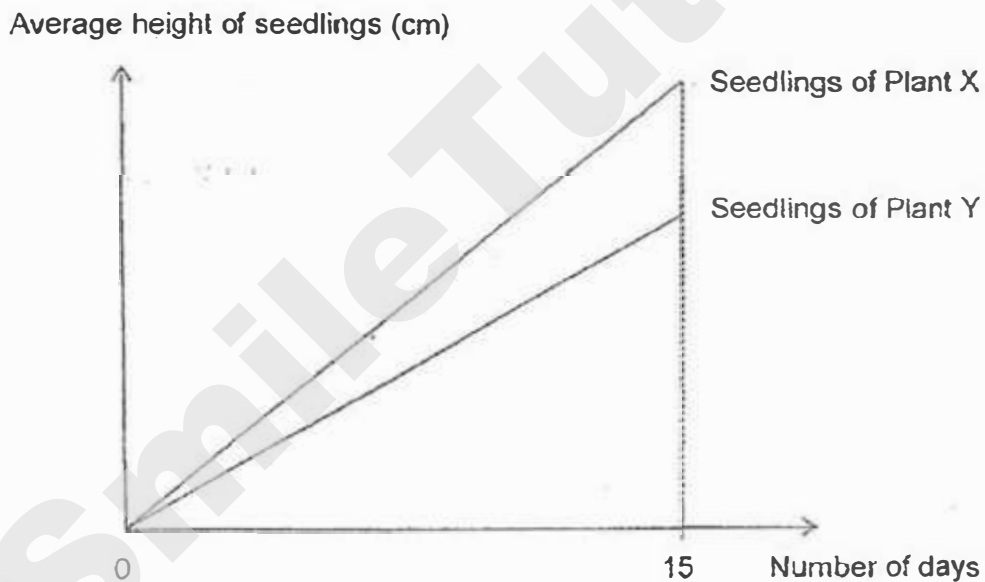

- (a) Compare the changes in the average height of both seedlings over 15 days. [1]

- (b) After 15 days, Alice went on a trip and left the seedlings unattended. When she came back 3 days later, she observed that all the seedlings in both beakers died. Suggest a possible reason why they died. [2]

- (c) Identify another variable that must be kept constant in order to conduct a fair experiment. [1]

33. The diagram below represents the human fertilisation process. Cells E and F are necessary for fertilisation to take place.

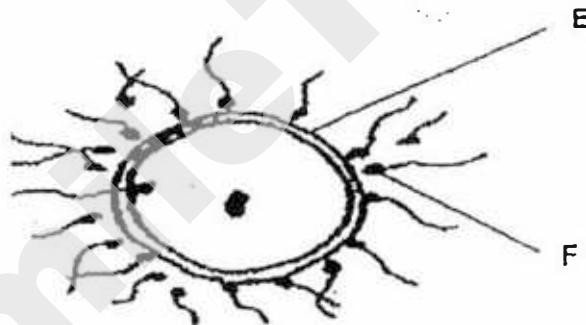

- (a) Identify cells E and F. [2]

E : _____ F : _____

The diagram below shows the parts of the reproductive system of a plant and human.



(b) Which part of the flower, R, P or Q, performs the same function as part Z? [1]

(c) Identify the parts where fertilisation will take place in the plant and female human reproductive systems respectively. Write the letters, P, Q, R, X, Y or Z, that represent the parts in the boxes below. [2]

		Letter that represents the part
(i)	Reproductive system of a plant	
(ii)	Reproductive system of a human	

34. Bogum prepared 3 set-ups as shown below. He then poured 300ml of water into each flask.

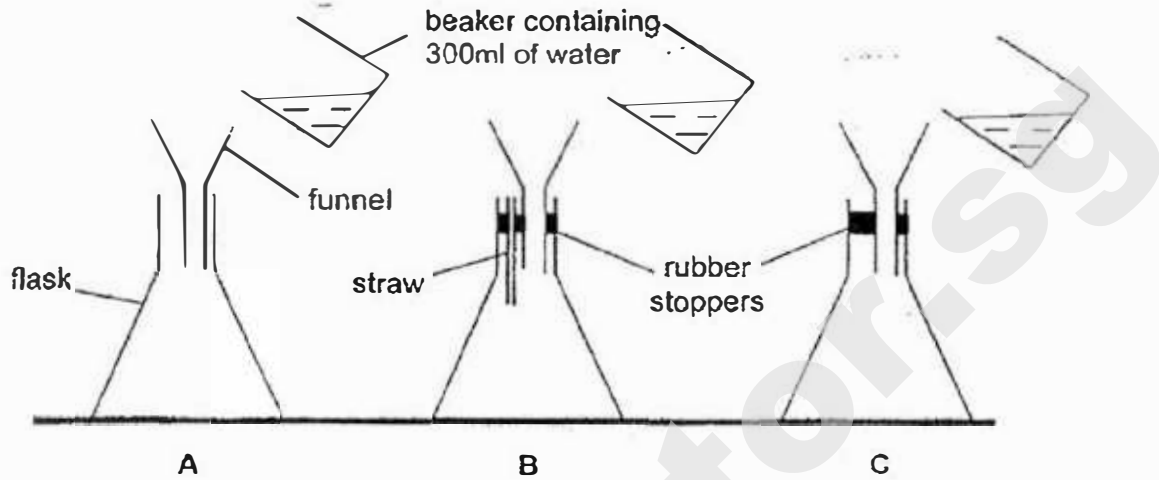

- (a) Based on the diagram above, which flask would collect the most amount of water in the shortest time? Explain your answer. [2]

- (b) This experiment shows that liquids occupy space. State another property of liquids that could be observed based on the experiment above. [1]

35. Junjie heated a beaker of ice and recorded the change in its temperature over a period of time in the graph below.

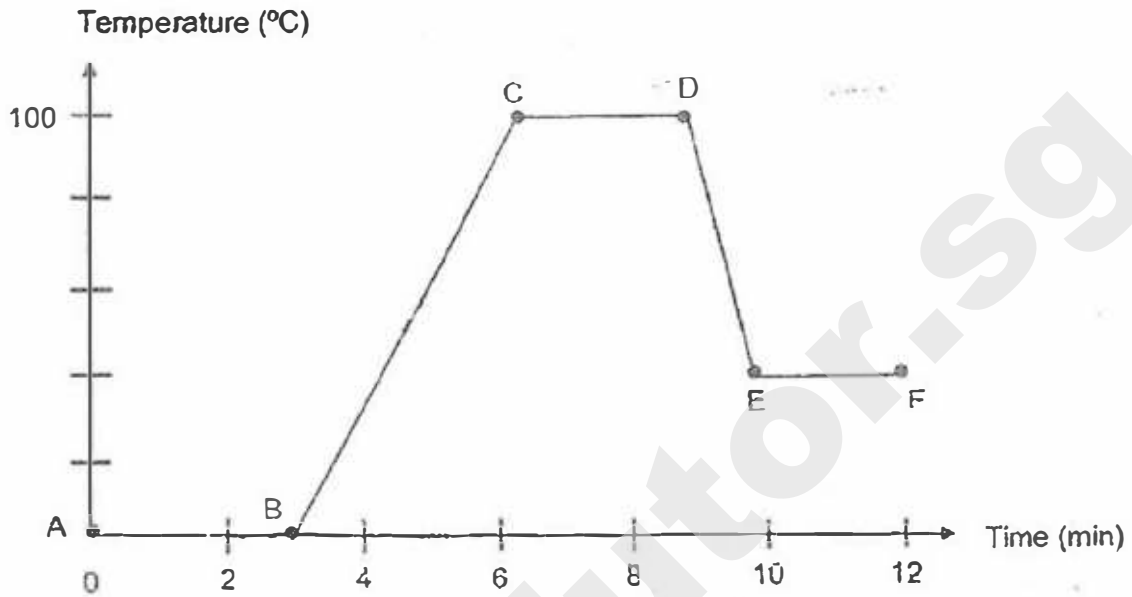

- (a) Which part of the graph shows a change in the state of water from solid to liquid? [1]

- (b) Why does the temperature remain constant for the period E to F? [1]

- (c) What is the process that takes place from the period C to D? [1]

36. Four identical towels, W, X, Y and Z, each containing the same amount of water, were left to dry under different conditions as shown below.

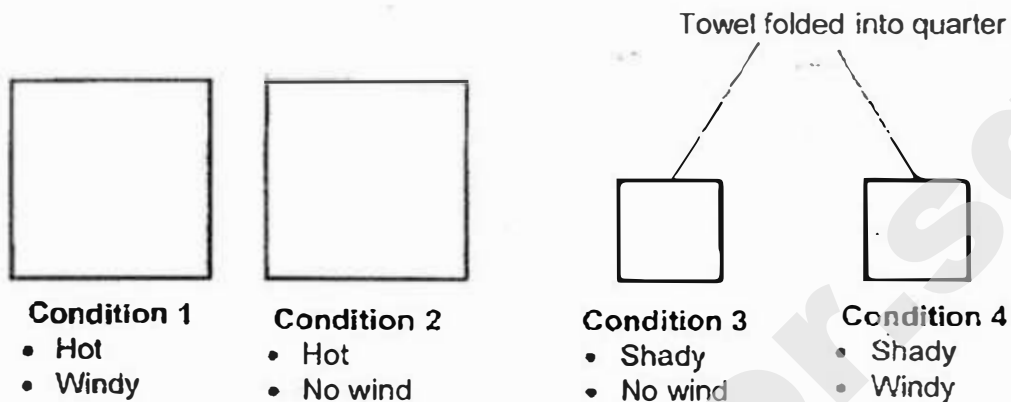

En Xi recorded the mass of each towel at the start of the experiment and again after 2 hours. The results are shown in the table below.

Towel	Mass of towel at the start of the experiment (g)	Mass of towel after 2h (g)
W	300	200
X	300	120
Y	300	80
Z	300	160

- (a) Based on the results in the table above, match the towels (W, X, Y and Z) to the correct conditions that they were left out to dry. [2]

Conditions	Towels
1	
2	
3	
4	

Another identical towel containing the same amount of water was folded into half and left to dry under a windy and shady location.

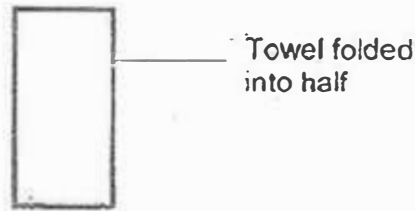

Condition

- Shady
- Windy

(b) What is the likely mass of the above towel after 2 hours? [1]

(c) En Xi wanted to hang her wet clothes out to dry. **Other than hanging the clothes out in the sun**, suggest another 2 methods that would enable her wet clothes to dry the fastest. [2]

(i) _____

(ii) _____

37. Joyce set up an experiment below. She carried out the experiment in three stages to find out how different types of materials allow different amounts of light to pass through them. Objects A, B, C and D are of the same shape and size but are made of different types of materials.

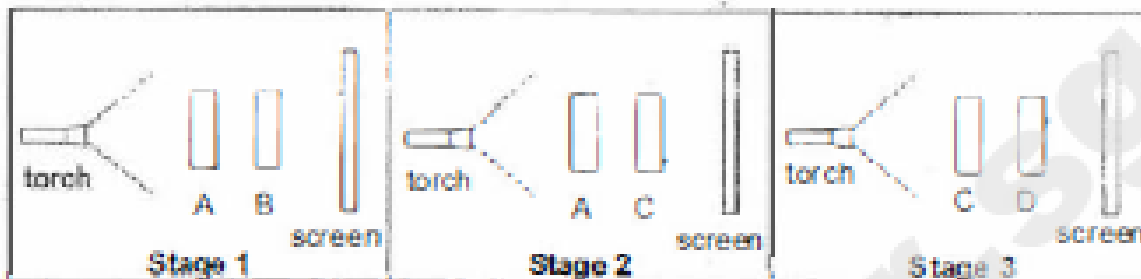

Joyce recorded her results in the table below.

Stage	Objects	Observation
1	A and B	There was a very faint shadow formed on the screen.
2	A and C	A dark shadow was seen on the screen.
3	C and D	A dark shadow was seen on the screen.

- (a) Put a tick (✓) in the appropriate boxes to indicate what conclusions she could draw based on her observations. [2]

Object	Allows most light to pass through	Does not allow light to pass through	Not possible to tell
A			
B			
C			
D			

Joyce repeated the experiment with only Object E placed between the torch and the screen. She observed that a dark shadow was formed on the screen.

- (b) Using the properties of light, explain how the shadow was formed. [1]

38. Keane had a glass bottle with a metal cap. He observed that it was easier to remove the metal cap after it was dipped into hot water for 5 minutes.

(a) Give a reason for his observation. [1]

Keane filled a glass cup with hot water quickly as shown in the diagram below.

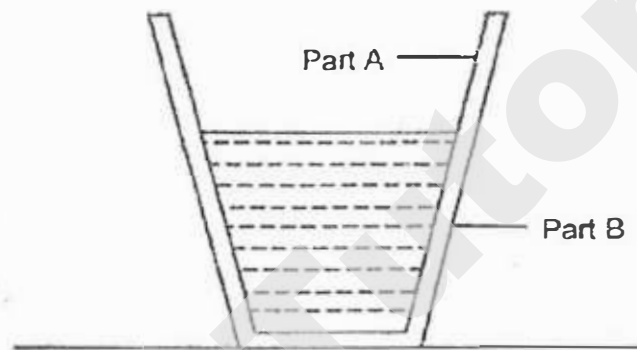

He observed that the glass cup cracked immediately.

(b) Explain why the glass cup cracked. [1]

(c) Suggest one way to prevent the glass cup from cracking when we pour the same amount of hot water into it. [1]

39. The table below shows the properties of materials, E, F, G and H, that are used to make a tent as shown in the table below.

Material	Strong	Waterproof
E	Yes	No
F	Yes	Yes
G		Yes
H	No	No

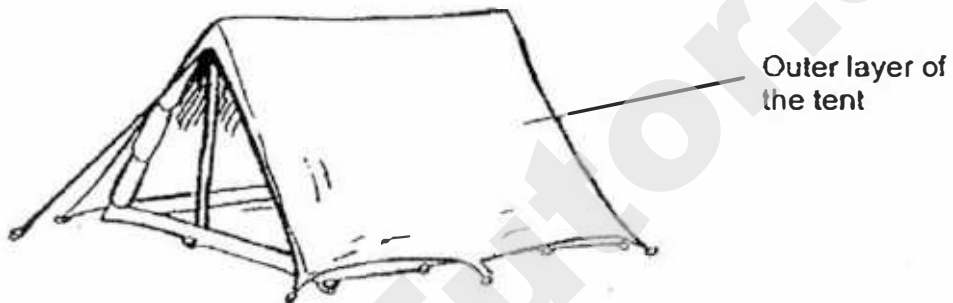

(a) Which material, E, F, G or H, is the most suitable for making the outer layer of the tent? Give 2 reasons for your answer. [2]

Material : _____

Reasons :

(i) _____

(ii) _____

(b) Name another property that the outer layer should possess in order to be used for outdoor camping. [1]

40. Cindy had a box of four rods, A, B, C and D, made of different materials. She put a magnet into the box to find out which rods were made of magnetic materials.

Rod	Material
A	Aluminium
B	Iron
C	Steel
D	Copper

- (a) Complete the table below by placing the four materials, A, B, C and D, under the correct headings. [1]

Attracted to the magnet	Not attracted to the magnet

- (b) She was given rod E which was made of a magnetic material. Describe how she could use her bar magnet to turn rod E into a magnet. [1]

41. Chong Boon bought a "floating" globe toy as shown below.

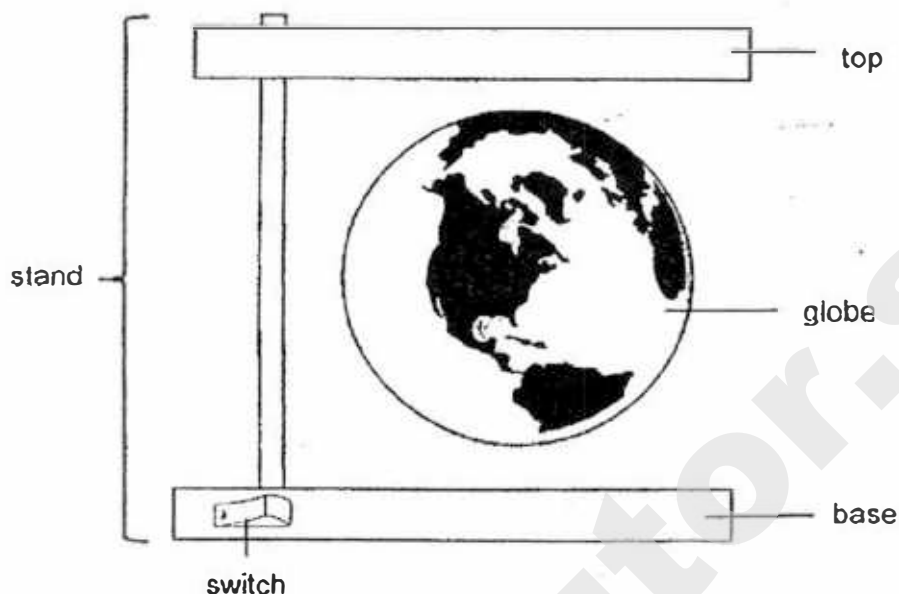

- (a) He observed that the globe was able to float. Using the concept of magnets, describe how the globe was able to float in the . [2]

Chong Boon placed the stand on the table which had some steel paper clips scattered around. Once he turned on the switch, he realised that some of the steel paper clips were attracted to the base of the stand.

- (b) Suggest why the steel paper clips were attracted to the base of the stand when the switch was turned on. [2]

End of paper

SCHOOL : NANYANG PRIMARY SCHOOL
LEVEL : PRIMARY 5
SUBJECT : SCIENCE
TERM : SA1

SECTION A

Q 1	Q2	Q3	Q4	Q5	Q6	Q7	Q8	Q9	Q10
1	3	1	1	1	1	2	4	2	4

Q 11	Q12	Q13	Q14	Q15	Q16	Q17	Q18	Q19	Q20
1	2	4	2	3	1	3	3	2	3

Q 21	Q22	Q23	Q24	Q25	Q26	Q27	Q28
2	3	4	4	3	2	1	2

SECTION B

Q29)	(a) A:Pollen tube B:Style (b) Male reproductive cell will enter from the stigma to the ovary to fuse with the female reproductive cell. (c) It allows the male reproductive cell to reach the ovary to fuse with the female reproductive cell.
Q30)	(a) As the stigma is still intact, pollen grains from a flower of the same species can still pollinate the flower and fertilisation can hence take place.

	(b) It will turn into seeds of the fruit.
Q31)	(a) Shorea / Angsana /Dandelion (b) As the strength of the wind increased, the number of seeds dispersed remains the same.
Q32)	(a) Seedlings of Plant X grew taller than seedlings of Plant Y. (b) The water in the cotton wool had been absorbed by the plant so it has not enough water to survive. (c) The number of seeds planted.
Q33)	(a) E: egg F: sperm (b) Q (c) (i) Q (ii) X
Q34)	(a) A. The most amount of air in A has escaped from the flask via the two tubes compared to B and C, hence water flows into the flask to occupy the space previously occupied by the water displacing the air. (b) Water has no definite shape.
Q35)	(a) A to B (b) It has reached room temperature. (c) Boiling
Q36)	(a) Y, X, W, Z (b) 140g (c) (i) Use a hair dryer to dry it (ii) Put it in a dryer
Q37)	(a) A → Allows most light to pass through B → Allows most light to pass through C → Does not allow light to pass through D → Not possible to tell (b) Light travels in a straight line so when it is blocked, it forms a shadow.
Q38)	(a) The cap gained heat and expanded. (b) A expanded faster than B. (c) Pour the hot water into the cup slowly.
Q39)	(a) Material: F (i) It needs to be strong to block fallen branches from hitting the people inside the tent. (ii) It needs to be waterproof so that the camper inside the tent will not get

	<p>wet.</p> <p>(b) It must be flexible.</p>
Q40)	<p>(a) B, C → Attracted to the magnet A, D → Not attracted to the magnet</p> <p>(b) Stroke rod E at least 20 times with a bar magnet in the same direction with the same pole of the magnet each time.</p>
Q41)	<p>(a) The globe and the stand had magnets that the like poles are facing each other to repel.</p> <p>(b) When he turned on the switch, the base of the stand became an electromagnet. Hence, the base attracted the paper clips which were made of magnetic material.</p>

SmileTutor.sg

Semestral Assessment 1 – 2017
Science
Primary 5

Name : _____ ()

Date : 9 May 2017

Class : Pri. 5 ()

Science Teacher : _____

Time : 1 h 35 min

Section A (28 × 2 marks)

For questions 1 to 28, choose the most suitable answer and shade its number (1, 2, 3 or 4) on the Optical Answer Sheet (OAS) provided.

1. Three bar magnets, AB, CD and EF, can be arranged as shown below.



Which of the following arrangements of the magnets is **not** possible?

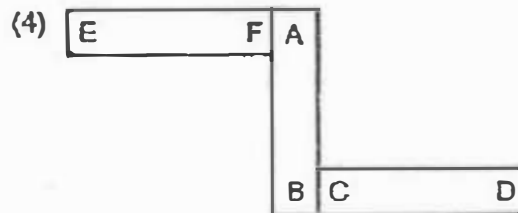
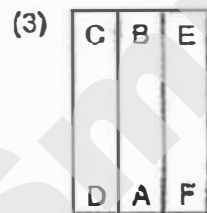
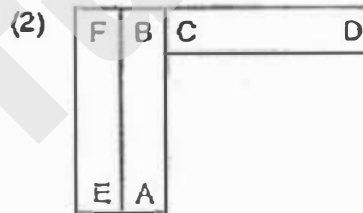
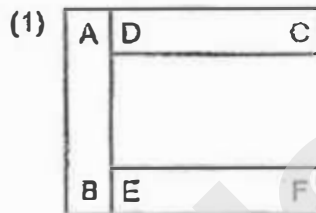

2. Ufang tried to magnetise a steel nail using the stroke method. She stroked the steel nail with a bar magnet as shown below. When she brought the steel nail near some paper clips, nothing happened.

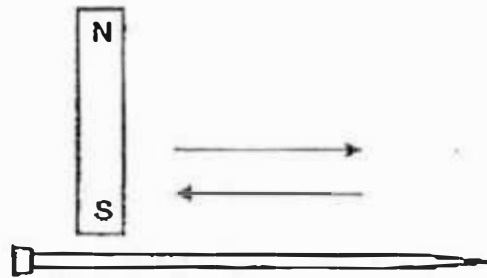

Which of the following could be the possible reason for her observation?

- (1) The bar magnet was too small.
 - (2) Steel is not a magnetic material.
 - (3) The steel nail was stroked in more than one direction.
 - (4) The steel nail was not stroked with the North pole of the magnet.
3. Yan Ling conducted an experiment using the set-up below.

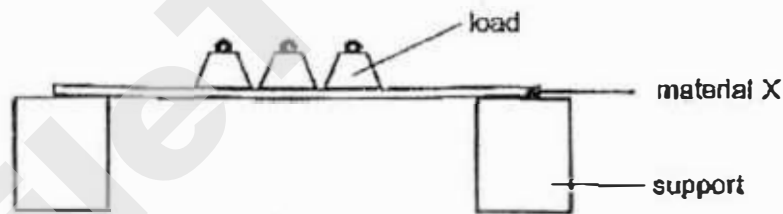

She increased the number of loads until material X broke.

The aim of her experiment was to find out _____

- (1) how strong the load was
 - (2) how heavy the load was
 - (3) how strong material X was
 - (4) how flexible material X was
4. Which of the following is not a function of the human skeletal system?
- (1) Protects the internal organs.
 - (2) Supports the body and gives it shape.
 - (3) Works with the muscular system to enable the body to move.
 - (4) Transports waste material away from different parts of the body.

5. The diagram below shows the human digestive system.

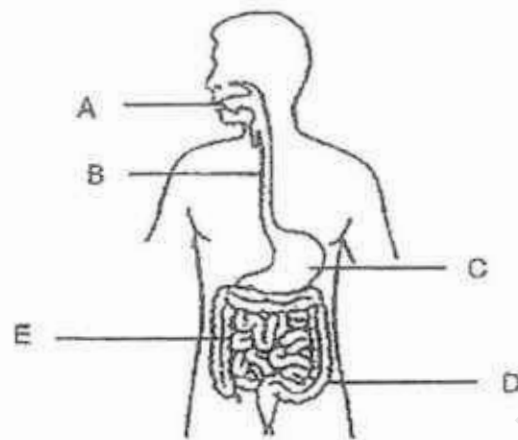

Where does digestion take place?

- (1) C and E only
 - (2) C, D and E only
 - (3) A, C and E only
 - (4) A, B, C and E only
6. The diagram below shows a sealed container. It has a capacity of 500 cm^3 and currently contains 150 cm^3 of water.

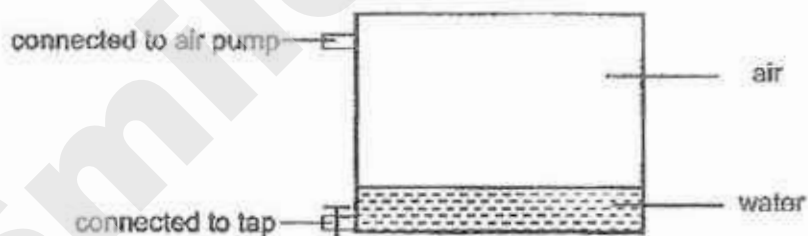

After 50 cm^3 of water was removed and an additional 100 cm^3 of air was pumped into the container, which of the following correctly shows the volume of air in the container?

- (1) 350 cm^3
- (2) 400 cm^3
- (3) 450 cm^3
- (4) 500 cm^3

7. The diagram below shows a beaker containing two substances, A and B.

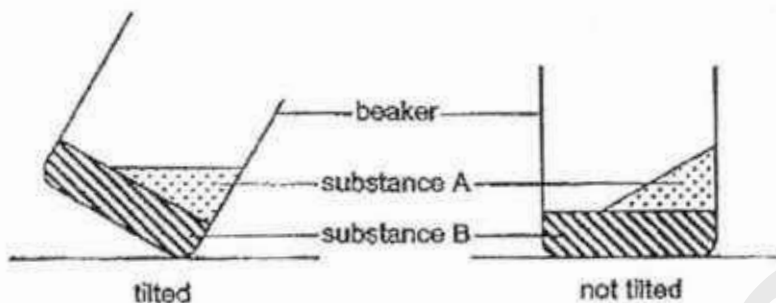

Based on your observations, which of the following correctly represents the state of matter of substances A and B?

	Substance A	Substance B
(1)	liquid	solid
(2)	solid	liquid
(3)	liquid	liquid
(4)	solid	solid

8. The graph below shows the number of days for each stage of the life cycle of insect Y.

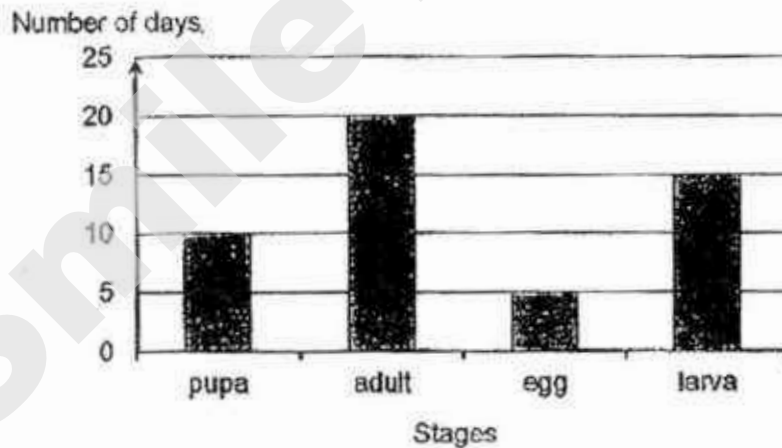

Based on the graph, which stage of the life cycle will insect Y be in 18 days after the egg has hatched?

- (1) egg
- (2) larva
- (3) pupa
- (4) adult

9. Jeremy wants to find out if light is needed for seeds to germinate. The table below contains information on set-ups A, B, C, D, E and F. Each set-up contains the same number of seeds.

Set-up	Temperature of surrounding (°C)	Presence of water	Presence of light
A	0	✓	
B	0	✓	✓
C	30	✓	✓
D	30		✓
E	30	✓	
F	30		

Which two set-ups should Jeremy choose to ensure a fair test?

- (1) A and B
- (2) A and C
- (3) C and E
- (4) D and F

10. The diagram below shows two sheets, S and T, with a shape cut out in the centre. Both are made of different materials.

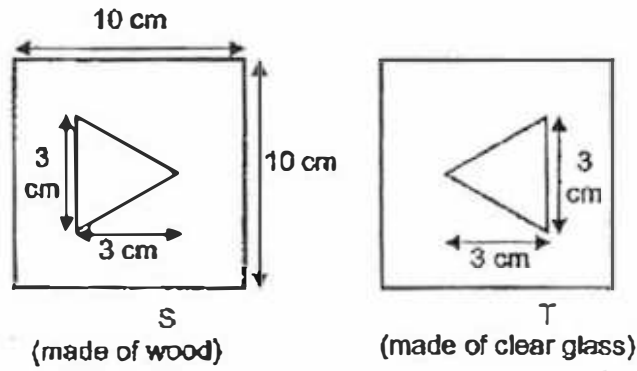

The sheets were then glued together and light was shone at them.

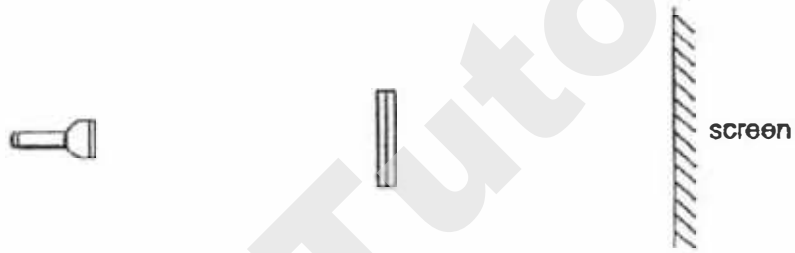

Which of the following correctly shows the shadow formed on the screen?

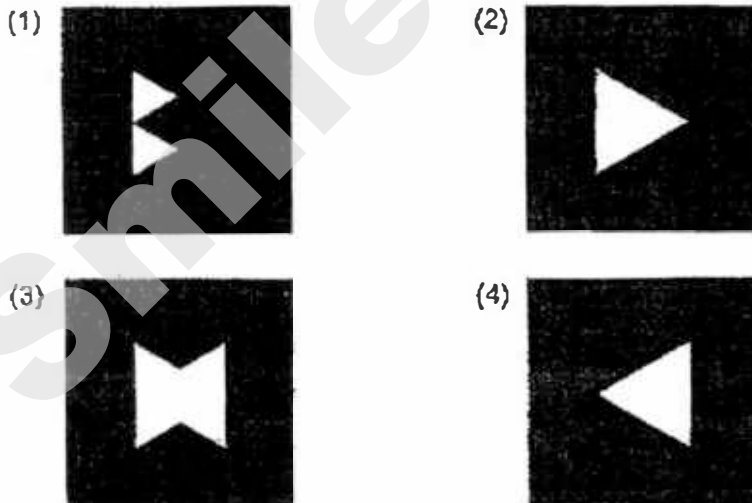

11. Mary walked in a straight line from X to Z as shown in the diagram below. At Y, she was directly under the lamp. The distance between X and Y is the same as the distance between Y and Z.

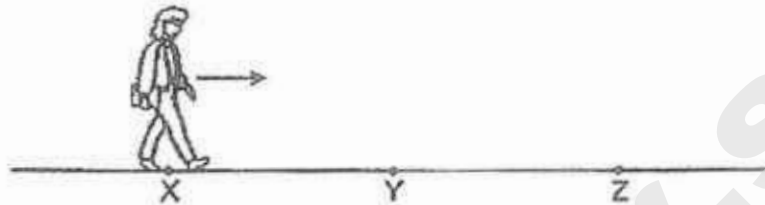

The graph below shows how the length of Mary's shadow on the ground changed during the walk.

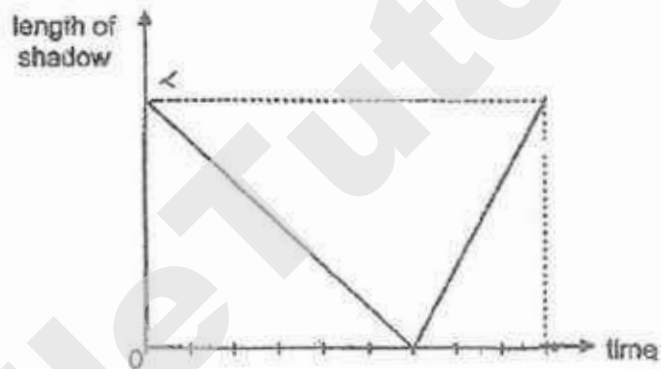

Based on the graph above, which of the following statements about Mary's walk is true?

- (1) She took a longer time to walk from Y to Z than to walk from X to Y.
- (2) She walked at a faster speed between X and Y than between Y and Z.
- (3) She walked at a slower speed between X and Y than between Y and Z.
- (4) As she walked towards the lamp from X to Y, her shadow became longer.

12. Meimei had two similar rods made of materials A and B. She wrapped a piece of white paper tightly round the middle of each rod and heated each piece of paper gently with a candle flame for a few minutes as shown in the diagram below.

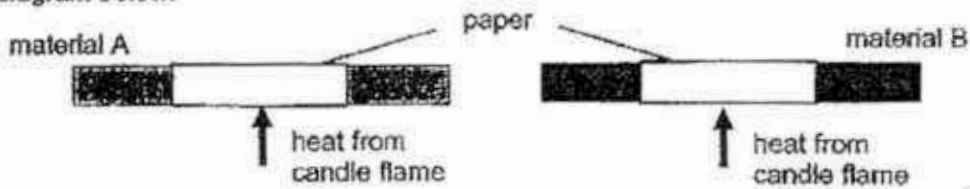

She removed the rods from the flame and examined the two pieces of paper. She recorded her observations in the table below.

Paper wrapped around	Appearance of paper
material A	remained white (unburnt)
material B	turned brown (slightly burnt)

Which of the following correctly explains Meimei's observations?

Which material is a better conductor of heat?	Explanation of observations
(1) A	Material A conducted heat away from the paper more quickly than material B.
(2) B	Material B conducted heat to the paper more quickly than material A.
(3) A	Material A conducted heat to the paper more quickly than material B.
(4) B	Material B conducted heat away from the paper more quickly than material A.

13. The diagram shows electricity cables being put up on a warm day. The cables are hung loosely between the poles, as shown in the diagram.

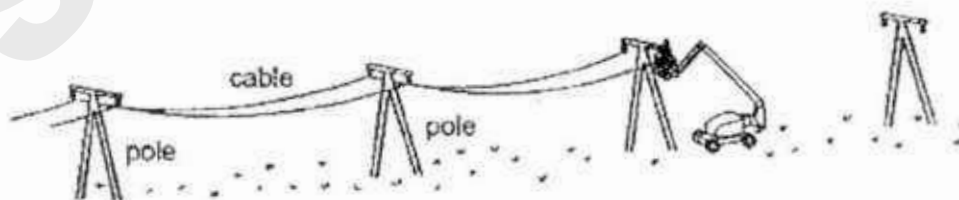

The cables are hung loosely to prevent the cables from breaking due to _____.

- (1) expansion of the cables on a hot day
- (2) contraction of the cables on a hot day
- (3) expansion of the cables on a cold day
- (4) contraction of the cables on a cold day

14. The diagram below shows a flowering plant.

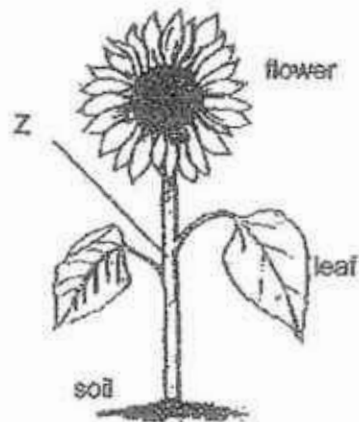

What is the direction in which water and food are being transported at Z?

Direction of transport of	
water	food
(1) upwards only	downwards only
(2) upwards only	both upwards and downwards
(3) downwards only	upwards only
(4) downwards only	both upwards and downwards

15. In which of the following parts of a plant are water-carrying tubes present?

- A : roots
- B : stem
- C : leaves
- D : flowers

- (1) B only
- (2) B and C only
- (3) A, B, and C only
- (4) A, B, C and D

16. Three test-tubes were set up as shown in the diagram and left in full sunlight.

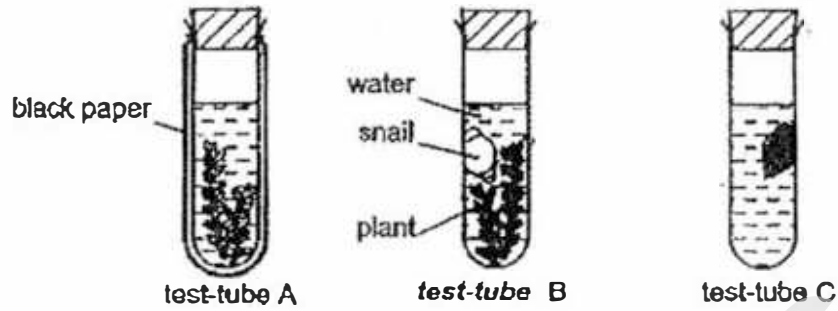

Which of the following correctly describes the change in the amount of carbon dioxide in the water after two hours?

	Test-tube A	Test-tube B	Test-tube C
(1)	decrease	increase	Increase
(2)	increase	not possible to tell	increase
(3)	not possible to tell	increase	increase
(4)	Increase	decrease	decrease

17. Study the flowchart given below.

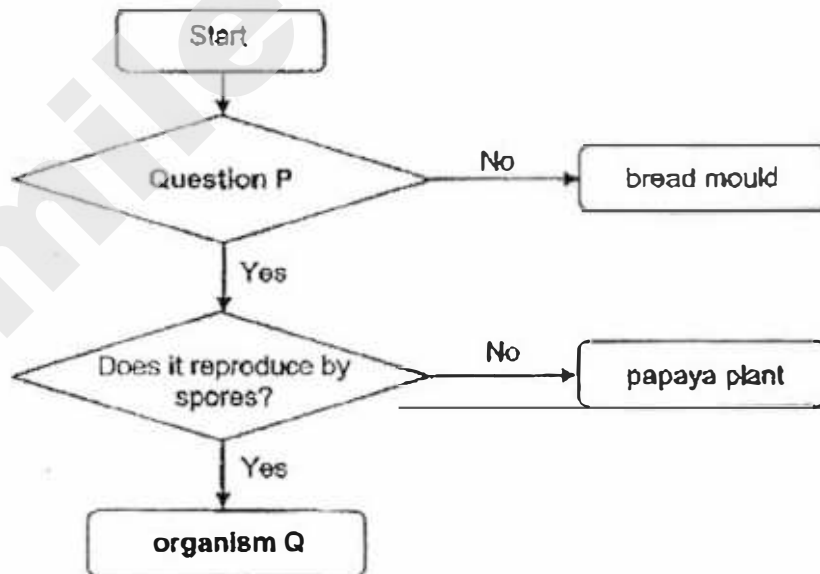

Which of the following is correct?

	Question P	Organism Q
(1)	Does it make its own food?	moss
(2)	Does it produce seeds?	moss
(3)	Does it make its own food?	mushroom
(4)	Does it produce seeds?	mushroom

18. Meena wanted to find out if the temperature of the surroundings affects the amount of water taken in by a plant. The diagram below shows one of her set-ups.

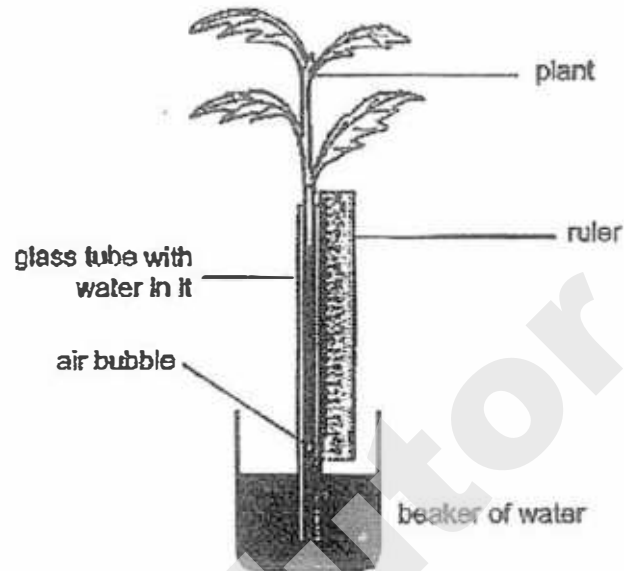

She placed the set-up in a room. She measured the temperature in the room and the distance moved by the air bubble at the end of the experiment. She repeated her experiment in the same room with another similar set-up.

Which of the following variables should be kept constant for a fair test?

- A : Temperature in the room X
- B : Duration of the experiment
- C : Number of leaves on the plant
- D : Position of the air bubble at the end of the experiment X

- (1) A and D
- (2) B and C
- (3) B, C and D
- (4) A, B, C and D

19. The diagram below shows how blood flows in certain parts of the body.

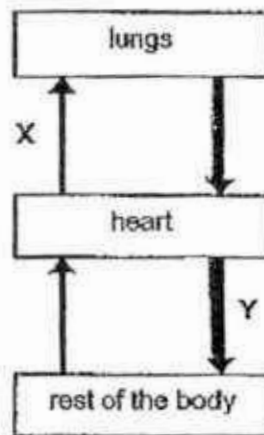

Which of the following about the blood at X and Y is correct?

	X	Y
(1)	high in carbon dioxide	high in oxygen
(2)	high in carbon dioxide	low in oxygen
(3)	low in carbon dioxide	high in oxygen
(4)	low in carbon dioxide	low in oxygen

20. The graph below shows the changes in Jeya's heart rate. He exercised and then stopped after some time.

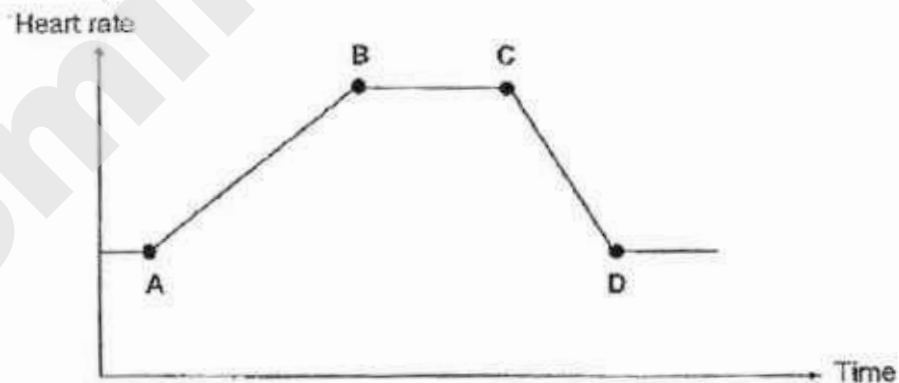

At which points, A, B, C or D, did Jeya start and stop exercising?

	Start exercising	Stop exercising
(1)	A	C
(2)	A	D
(3)	B	C
(4)	B	D

21. The diagram below shows how different types of cells are classified according to certain characteristics, A, B, W, X, Y and Z.

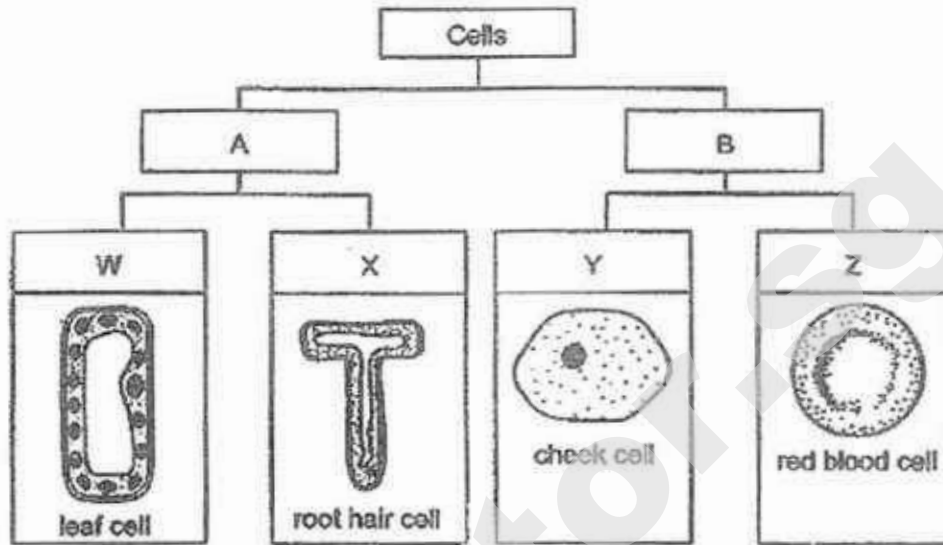

Which of the following is correct?

	W	B
(1)	Has cell wall	Does not have chloroplasts
(2)	Has chloroplasts	Has cell membrane
(3)	Has cell wall	Has cell membrane
(4)	Has chloroplasts	Does not have cell wall

22. The diagram below shows a plant cell.

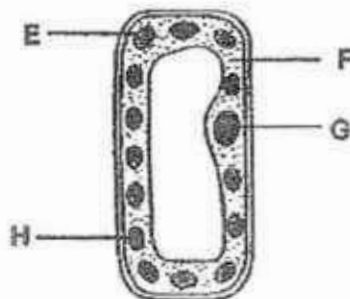

Which part of the cell is not likely to be found in a yeast cell?

- (1) E
- (2) F
- (3) G
- (4) H

23. The diagram below shows two flowers of the same plant.

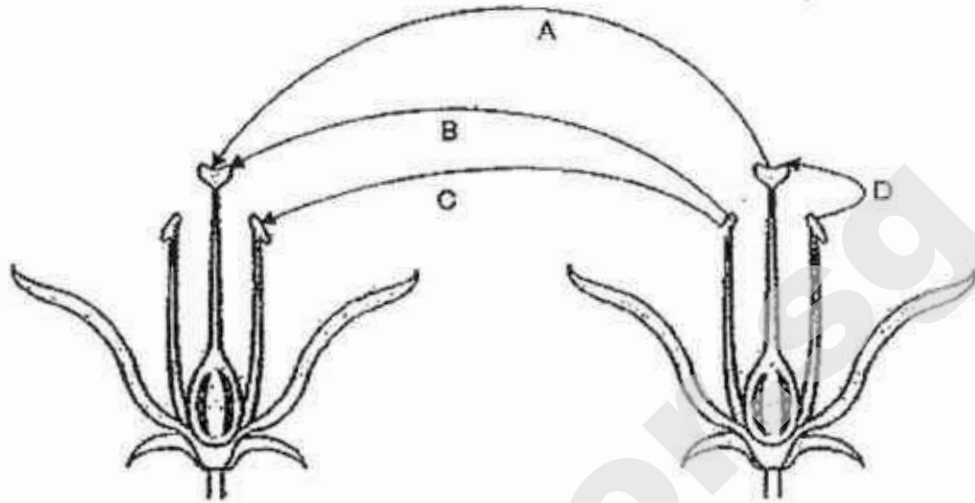

Which of the above arrows represent(s) the process of pollination?

- (1) A only
- (2) B only
- (3) B and D only
- (4) A, B and C

24. Lily counted the number of wild plants X and Y in an area near a river. After three months, she counted the number of plants growing in the same area again. Her observations are shown below.

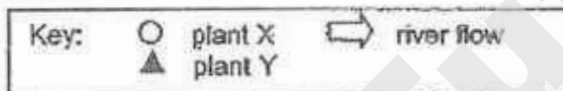
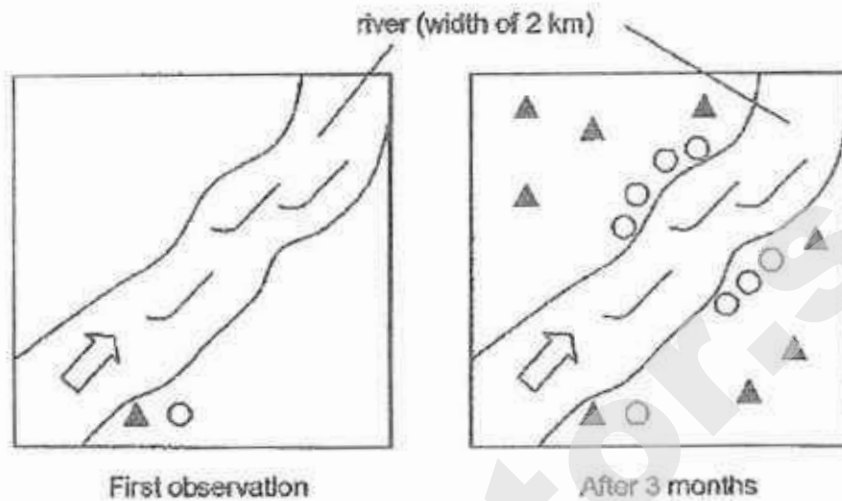

Which of the following correctly describes how the seeds/fruits of plants X and Y were dispersed?

	Plant X	Plant Y
(1)	by wind	by water
(2)	by water	by splitting of fruits
(3)	by wind	by splitting of fruits
(4)	by water	by animals

25. Study the circuit below. The batteries and bulbs are all working properly.

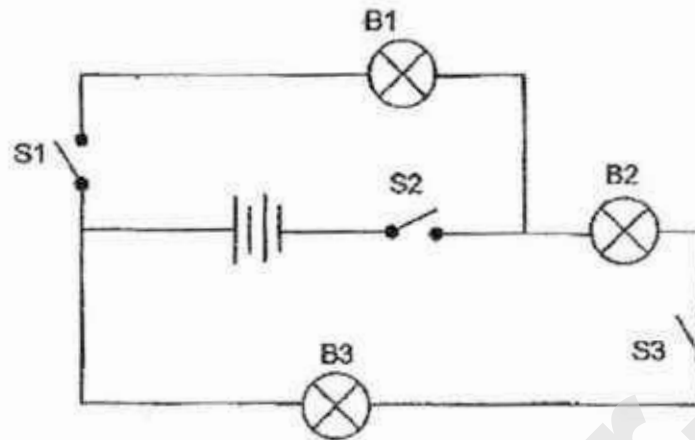

Which of the following observations is possible?

(1)

Switch			Bulb		
S1	S2	S3	B1	B2	B3
off	on	on	lit up	did not light up	did not light up

(2)

Switch			Bulb		
S1	S2	S3	B1	B2	B3
on	off	on	lit up	lit up	lit up

(3)

Switch			Bulb		
S1	S2	S3	B1	B2	B3
on	on	off	lit up	did not light up	did not light up

(4)

Switch			Bulb		
S1	S2	S3	B1	B2	B3
on	on	off	lit up	lit up	did not light up

26. In the circuits below, all the bulbs and batteries used are identical.

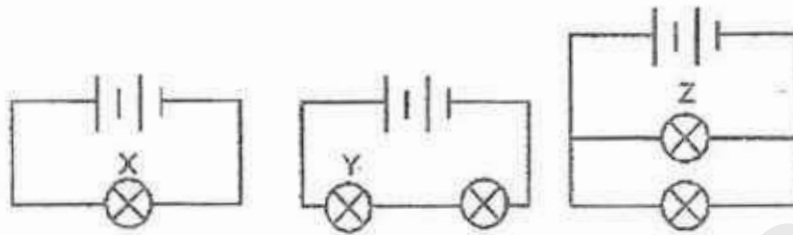

Which of the following conclusions about the three circuits is correct?

- (1) Bulb Z is the dimmest.
 - (2) Bulb X is as bright as bulb Z.
 - (3) Bulb X is brighter than bulb Z.
 - (4) Bulb Y is brighter than bulb X.
27. In the circuit below, all the six bulbs are lit.

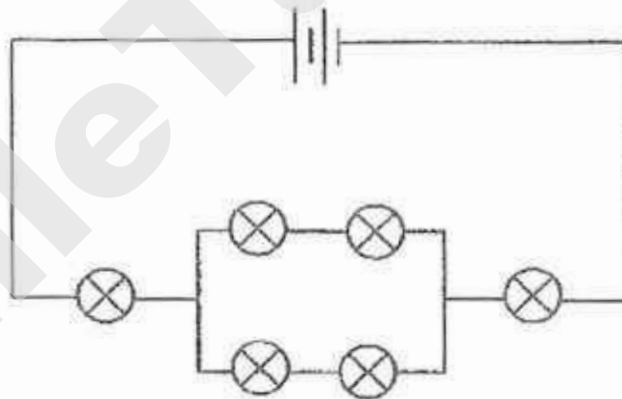

What is the largest number of bulbs that will remain lit when one of the bulbs is fused?

- (1) 0
- (2) 2
- (3) 4
- (4) 5

28. Colin had four materials K, L, M and N. He connected all the materials in a circuit and recorded his observations as shown in the diagrams below.

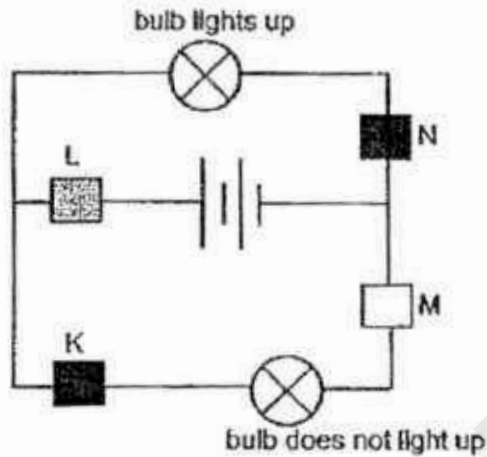

Next, Colin re-arranged the materials in the same circuit and recorded his observations as shown in the diagram below.

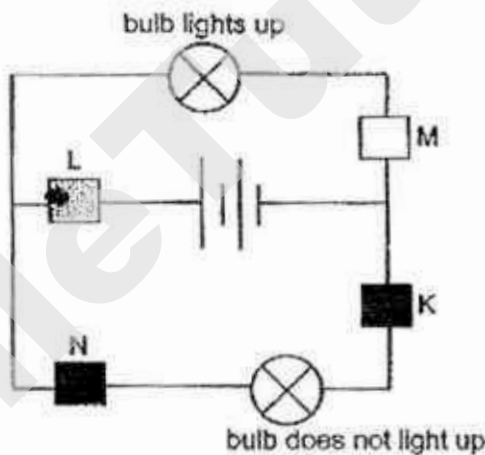

Based on Colin's observation, which of the following correctly classified the materials?

	Electrical Conductor(s)	Electrical Insulator(s)
(1)	L	K, M and N
(2)	K	L, M and N
(3)	L and M	N and K
(4)	L, M and N	K

End of Section A

**Semestral Assessment 1 –
2017 Science
Primary 5**

Name : _____ ()

Class : Pri. 5 ()

Date : 9 May 2017

Time : 1 h 35 min

Science Teacher : _____

Parent's signature: _____

Section A	56
Section B	34
Practical test	10
Total	100

Section B (34 marks)

For questions 29 to 38, write your answers in the spaces provided.

29. Junheng used the set-up below to study a certain property of material.

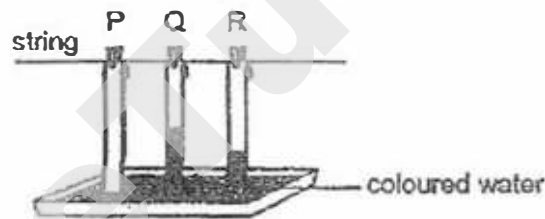

He hung three dry strips of different materials, P, Q and R, on a string and let the ends of each strip touch a tray of coloured water. The strips were of the same length and hung from the same height. After ten minutes, he measured the length of each strip that was stained by the coloured water.. His results are shown below.

Material	Length of material stained by coloured water (cm)
P	0
Q	12
R	5

- a) Name the property of material that is being tested. [1]

- b) Based on his results, which material is the most suitable to be used for making a rain coat? Explain your answer. [1]

SCORE	
-------	--

30. Muthu observed that magnet K and object Y were attracted as shown below.

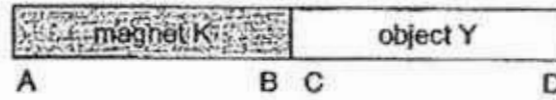

- a) Give a reason why Muthu cannot conclude whether object Y is a magnet or not based on the observation. [1]

- b) Using only magnet K and object Y, what should Muthu do to conclude whether object Y is a magnet? Explain your answer. [2]

31. Lenny removed the bottom half of a plastic bottle and placed the top half on the surface of the water as shown in diagram 1. Diagram 2 shows what he observed after he had pushed the bottle into the water.

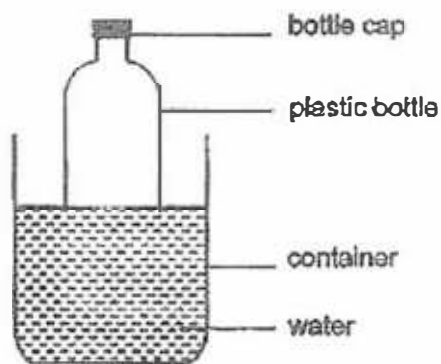

diagram 1

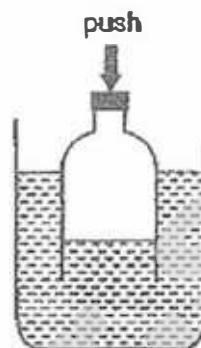
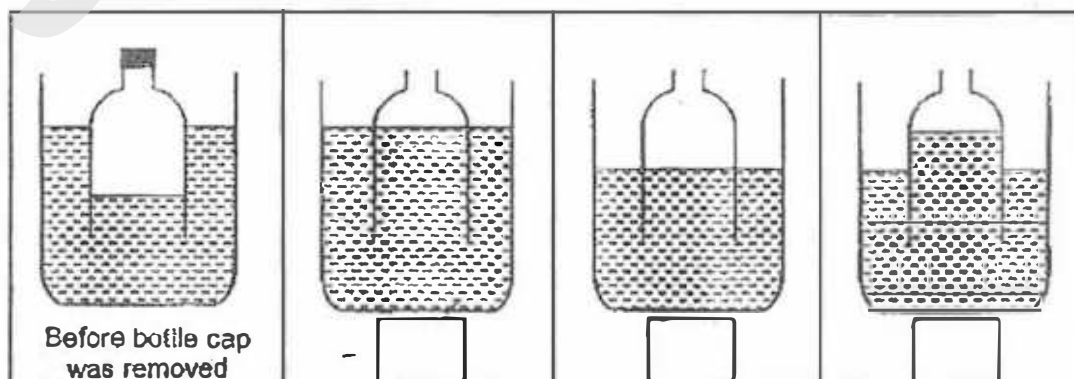

diagram 2

- a) Lenny observed that some water entered the plastic bottle when it was pushed down but the water level in the bottle was lower than the water level in the container. Explain his observations. [2]

- b) Lenny removed the bottle cap. He observed that the water level in the bottle went up. Explain his observation. [1]

- c) Which of the following diagrams correctly shows the water levels in both the container and the bottle after the bottle cap had been removed? Choose your answer by ticking (✓) in the box below the diagram. [1]



SCORE	<input type="text"/>
-------	----------------------

32. Xiao Ming set up the experiment shown below. When the torch was switched on, a dark shadow of the wooden block was formed on the wall.

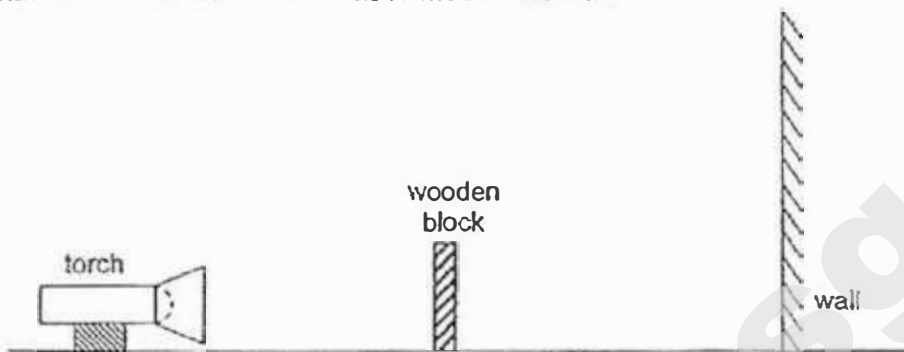

Xiao Ming wanted to find out how variable X would affect the height of the shadow formed on the wall. He changed variable X and measured the height of the shadow formed. He did not move the torch throughout his experiment.

His results are shown below.

Variable X (cm)	Height of shadow formed (cm)
5	18
10	12
15	8

- a) State two properties of light that cause shadows to form. [2]

Property 1: _____

Property 2: _____

- b) What is variable X? [1]

- c) Give a reason why the same wooden block must be used throughout the experiment to ensure a fair test. [1]

- d) Xiao Ming replaced the wooden block with a similar block made of frosted glass. He observed that the shadow formed on the wall was lighter. Give a reason for his observation. [1]

SCORE	
-------	--

33. Aziz learnt that the cell membrane allows certain substances to enter and leave a cell. He conducted an experiment to find out if the cell membrane allows water to pass through. He soaked an animal cell in a dish of water. After a while, the animal cell appeared swollen. The diagram below shows his observation.

original animal cell cell swelled in size



- a) Based on his observation, what could Aziz conclude about the cell membrane of the animal cell? [1]

- b) Aziz also observed that the animal cell in the dish of water burst after some time as shown below.

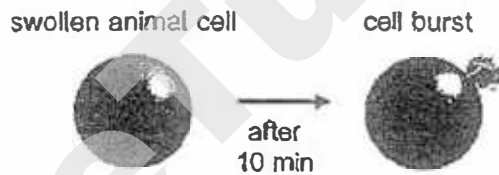

Aziz repeated the experiment with a plant cell. He soaked the plant cell in a dish of water for one hour. He observed that the plant cell appeared swollen but did not burst after one hour.

original plant cell cell swelled in size

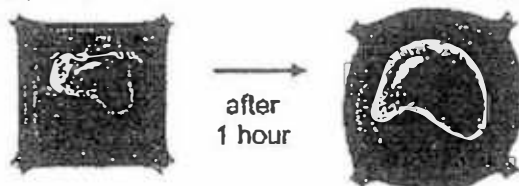

- Which part of the plant cell prevented it from bursting like the animal cell? [1]

SCORE	
-------	--

34. Veron conducted an experiment using three plastic cups as shown below. In set-up S, two of the plastic cups were placed one inside the other. A rubber ring kept the two cups separated so that the air between the cups was trapped. 200 cm³ of water was poured into the cups in the two set-ups.

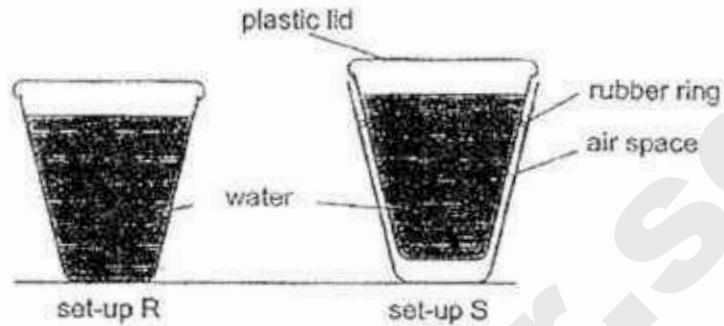

She placed both set-ups on a table. She measured and recorded the temperature of the water in both set-ups at different times. Her results are shown in the graph below.

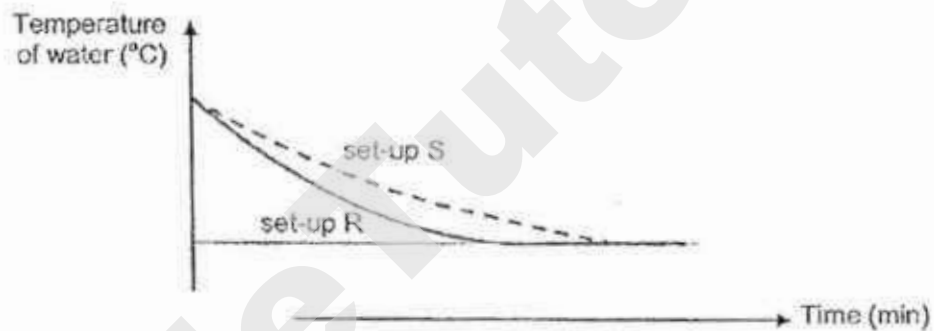

- a) Explain why the temperature of the water in set-up R decreased with time. [1]

- b) Based on Veron's results, what could she conclude about the conduction of heat by air? Explain your answer. [2]

Continue on the next page

SCORE	
-------	--

c) The diagram below shows two building materials, A and B.

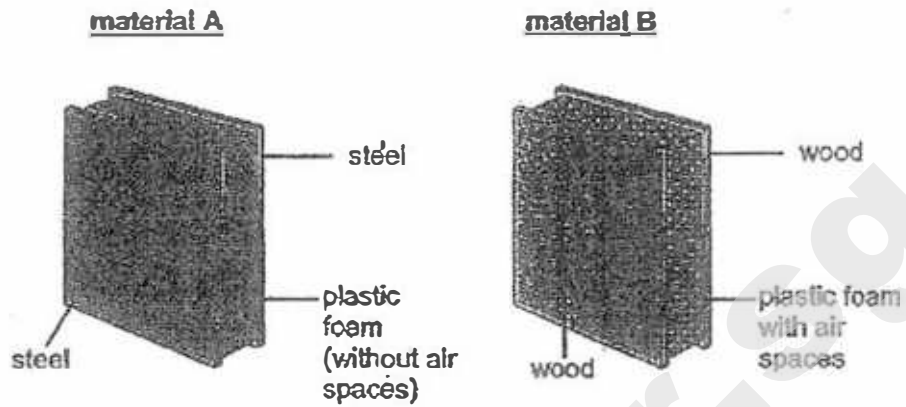

Based on Veron's experiment, explain how walls made of material B would help keep the inside of a house cooler on a hot day, as compared to walls made of material A.

[2]

SCORE	
-------	--

35. Yuki set up an experiment using four similar leaves, A, B, C and D, from plant X. These leaves have openings known as stomata on both their upper and lower surfaces. Leaves lose water through the stomata.

She cut the leaves from the plant and coated some surfaces of the leaves with oil that did not drip as shown in the table below.

Leaf	Coated with oil	
	Upper surface	Lower surface
A	no	no
B	yes	yes
C	no	yes
D	yes	no

She weighed each of the leaves and hung them up in an open area. After five hours, each leaf was weighed again and the loss of mass of each leaf was recorded.

- a) Which leaf, A, B, C or D, would have the greatest loss in mass? Explain your answer.

[1]

- b) Yuki wanted to compare the number of stomata on the upper and lower surfaces of the leaf of plant X. The table below shows the results for leaf C and D.

Leaf	Loss in mass (g)
C	1
D	0.05

Based on her results, what could Yuki conclude about the number of stomata on the upper and lower surfaces of the leaf of plant X?

[1]

Continue on the next page

SCORE	
-------	--

36. The graph below shows the rate of blood flowing to the muscles in Devi's body when she was at rest and exercising.

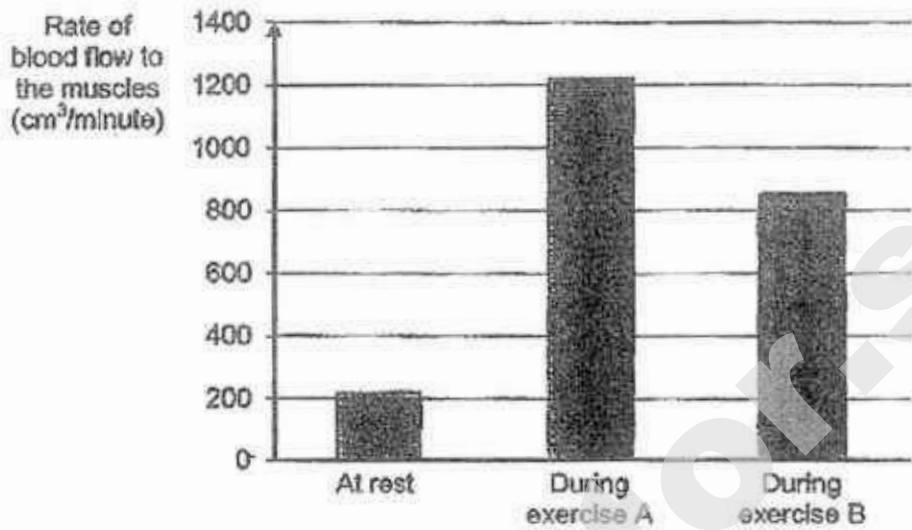

- a) Explain why blood had to flow more quickly to Devi's muscles when she was exercising. [2]

- b) Based on the graph, which type of exercise, A or B, would cause Devi's heart rate to be lower? Explain your answer. [1]

SCORE	
-------	--

- c) Yuki conducted another experiment with two similar pots of plant as shown below. The plants were watered with the same amount of water at the start of the experiment. She only coated the surfaces of all the leaves on plant S with oil that did not drip.

The two identical glass tanks were sealed and left in a well-lit place for three hours.

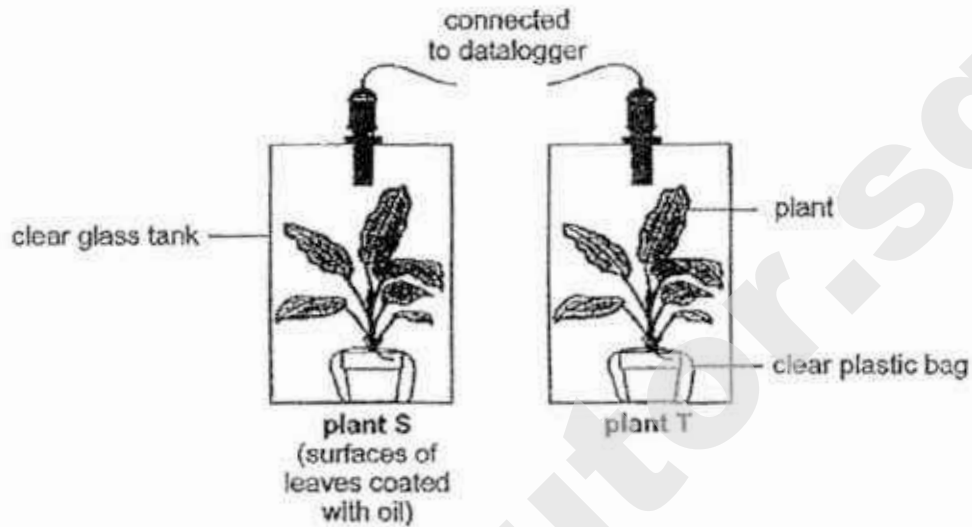

She measured the amount of oxygen in the tanks at the start and at the end of the experiment.

In which tank would there be more oxygen at the end of the experiment?
Explain your answer.

[2]

There would be more oxygen in the tank with plant _____.

SCORE	
-------	--

37. Wei Cheng carried out an experiment to find out how the height at which fruit M is dropped affects the distance it travels. The diagram below shows fruit M.

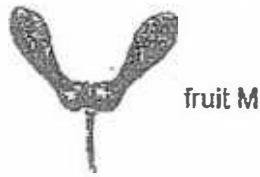

- a) Based on the diagram, suggest the method of dispersal for fruit M. Give a reason for your answer.

[1]

He dropped fruit M from a height (H) in front of a fan as shown. He measured the distance (D) travelled by the fruit.

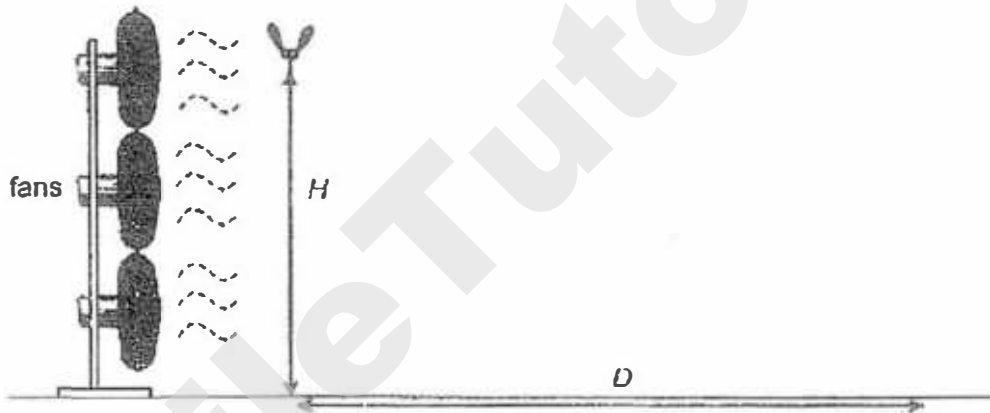

He repeated his experiment by dropping fruit M from different heights. The table below shows the results of his experiment.

H (cm)	140	120	100	80
D (cm)	60	50	44	35

- b) State how the distance (D) travelled by the fruit changes with the height (H) at which it was dropped.

[1]

- c) Based on the results, why is it an advantage for fruit M to be found growing on a tall parent plant?

[1]

SCORE	
-------	--

38. Rajoo constructed a circuit for a doorbell as shown in diagram 1. X is an iron bar inside a coil of insulated wire. A short while after he had closed the switch, steel rod Y moved up and the hammer hit the bell as shown in diagram 2.

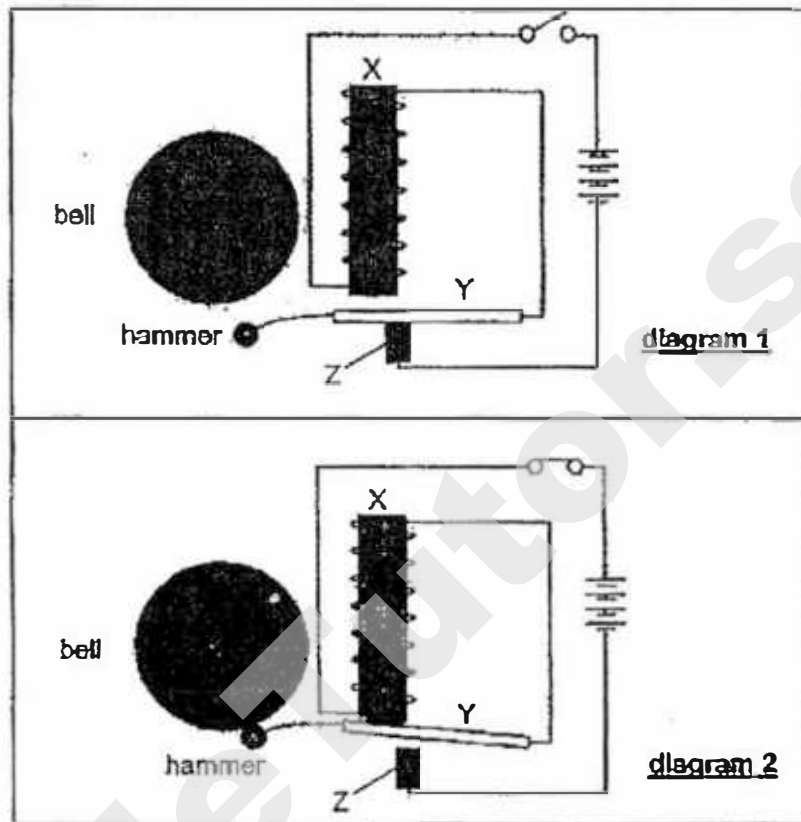

- a) Explain why the hammer hit the bell after Rajoo closed the switch. [1]

- b) After the hammer has hit the bell, Rajoo observed that rod Y moved down and touched bar Z again. Explain why rod Y moved down. [1]

- c) Rajoo replaced steel rod Y with a similar rod made of aluminium. Would the hammer still hit the bell after he had closed the switch? Give a reason for your answer. [1]

SCORE	
-------	--

EXAM PAPER 2017 (P5)

SCHOOL : PEI CHUN

SUBJECT : SCIENCE

TERM : SA1

Q1	Q2	Q3	Q4	Q5	Q6	Q7	Q8	Q9	Q10
2	3	3	4	3	2	4	3	3	2
Q11	Q12	Q13	Q14	Q15	Q16	Q17	Q18	Q19	Q20
3	1	4	2	4	2	1	2	1	1
Q21	Q22	Q23	Q24	Q25	Q26	Q27	Q28		
4	1	3	4	3	2	3	4		

Name: _____

Class: _____

P5 Semestral Assessment 1 (2017) - Corrections

29. *Concept:*

- A waterproof material does NOT absorb water.

a) Adsorbency of water / Ability to absorb water

Compare the materials

b) P. only material P is water proof

30. *Concept:*

- A magnet attracts magnetic material.
- Like poles of magnets repel each other.

a) Even though magnet K attracted object Y, object Y could be a magnetic object.

b) Action: Place end B of magnet K next to end D of object Y.
Conclusion: If they repel each other, object Y is a magnet.

31. *Concept:*

- Air occupies space.
- Air can be compressed

a) **Observation 1:**
There was air occupying the space in the bottle.
Observation 2:
The air in the bottle was compressed.

b) The air in the bottle could escape through the mouth of the bottle.

32.

a) Properties of light:

1: Light travels in a straight line.

2: A shadow is formed when light is blocked.

b) Only the position of the ~~torch~~ ^{block} could be changed.
When variable X increases, the height of the shadow decreases.
(When the block is further away from the torch, the shadow will be shorter.)

Distance between the wooden block and the torch.

c) Other than the tested variable, we keep other variables the same so that they would not affect the results of an experiment. Do not give a general statement.

The size (variable) of the wooden block will affect the height of the shadow (results)

d) Compare the properties of frosted glass and wood.

Frosted glass allows some light to pass through but wood does not allow light to pass through.

33. When asked for a conclusion, you must refer to the aim of the experiment.

a) Aim: "to find out if the cell membrane allows water to pass through."

Cell membrane (allows / does not allow) water to pass through it .

b) Which part of the cell gives it a regular shape?

cell wall

34. Concepts:

- a)
- When an object loses heat, its temperature decreases.
 - When an object gains heat, its temperature increases.

The water in set-up R
(gained heat from / lost heat to) the surroundings.

- b) Refer to the graph, the temperature of the water in set-up S took a longer time to fall to room temperature and that tells us that the trapped air between the cups caused the water to lose heat slower.

Air is a poor conductor heat

The water in set-up S lost heat slower than the water in set-up R.

- c) Compare material A and B (steel and wood, air spaces?)
In part (b), we learnt that trapped air is a poor conductor of heat.

The wall will gain heat from the air outside the house and the sun. The heat will pass through the wall and the air inside of the house will gain heat from the wall.

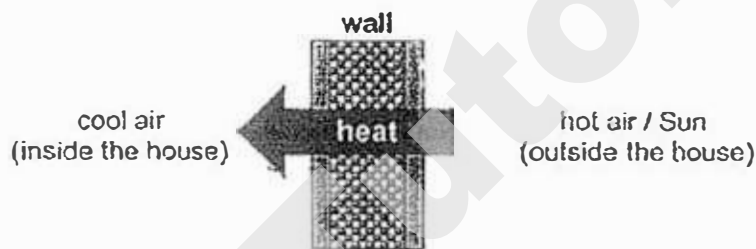

Discuss how the trapped air in the air spaces and wood are going to affect the heat transfer.

Wood is a poorer conduct of heat than steel.

The trapped air and wood would (reduce / increase) heat (gain / loss) from the hot air outside of the house / Sun.

35 Concept:

- a) • Leaves lose water through the stomata.
• Stomata allow exchange of gases in plants.
• Oil blocks the stomata on the leaves and prevents the exchange of gases.

Compare the leaves.

Leaf A, None of the stomata leaf A was blocked by oil. Thus, the leaf lost the most water

- b) Leaf C lost more water than leaf D. It has (more / fewer) stomata blocked by oil. If lower surface was covered in oil.

There are fewer stomata on the lower surface of the leaf.

- c) Concepts:
- Oil on the leaf prevented air from entering and leaving through the stomata.
 - Plants take in carbon dioxide for photosynthesis and produce oxygen.

Compare plants S and T

(The leaves on plant S were coated in oil which prevented air from entering and leaving through the stomata so) Plant S could not take in carbon dioxide and carry out photosynthesis

However, plant T could take in carbon dioxide. It could carry out photosynthesis and produce oxygen. Thus, there would be more oxygen in the tank with plant T.

36 Concepts:

- a)
- The human body uses oxygen and digested food to produce energy.
 - Oxygen and digested food are transported around the body in the blood.

Answer the question directly. Do NOT just write down what you have memorised.

"When we exercise, we need more energy. Our heart pumps faster to transport more digested food and oxygen in the blood to all parts of our body to produce more energy."

When Devi was exercising, she needed more energy.

The blood in her body had to flow more quickly to transport more digested food and oxygen to her muscles to produce more energy.

- b) Lower heart rate → blood flows (faster / (slower))

Exercise B. Her blood was flowing slower during the exercise and the exercise required less energy.

37
a) Fruit M has wing-like structure so it is dispersed by wind.

b) As the height at which the seed was dropped decreased, the distance travelled by it decreased.

c) **Concept:**
• *Plants disperse their seeds to prevent overcrowding so as to reduce competition for sunlight, water and minerals between the young plants and the parent plants.*

Refer to the results of the experiment:

tall parent plant → seed would be dropped higher from the ground and seed would travel further away from the parent plant.

The seeds would be dispersed further away from the parent plant and there would be less competition for sunlight, water and minerals among the plants.

38
a) When the circuit was closed, bar X became an electromagnet and attracted rod Y.

b) When rod Y moved up to touch bar X, the circuit was open. Bar X was no longer an electromagnet and could not attract rod Y.

c) No. Aluminium is a non-magnetic material so bar X could not attract the aluminium rod for the hammer to hit the bell.

Section A

SEMESTRAL ASSESSMENT (1)
2017

Your score
out of 100

Name : _____ Index No: _____ Class: P 5 _____

Parent's
signature

9 May 2017 SCIENCE Attn: 1 h 45 min

SECTION A (28 X 2 marks)

For each question from 1 to 28, four options are given. One of them is the correct answer. Make your choice (1, 2, 3 or 4). Shade the correct oval on the Optical Answer Sheet.

1. Lily placed four identical animals in four different containers. In which container will the animal be able to survive for the longest period of time?

(1)

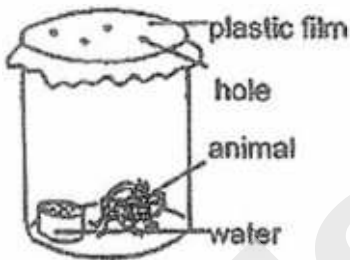

(2)

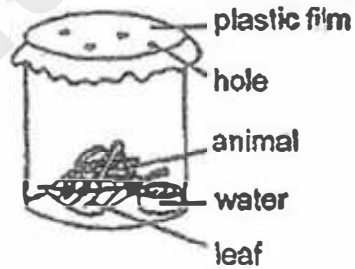

(3)

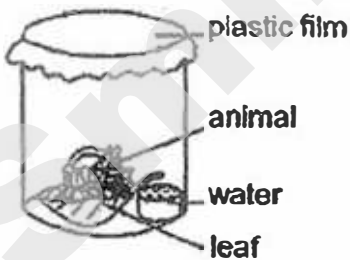

(4)

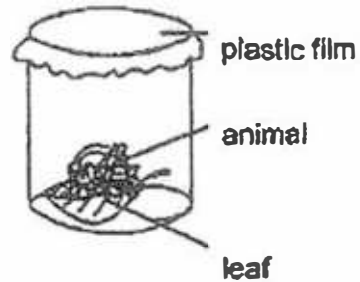

2. Study the pictures of fruits, A, B, C and D, as shown below.

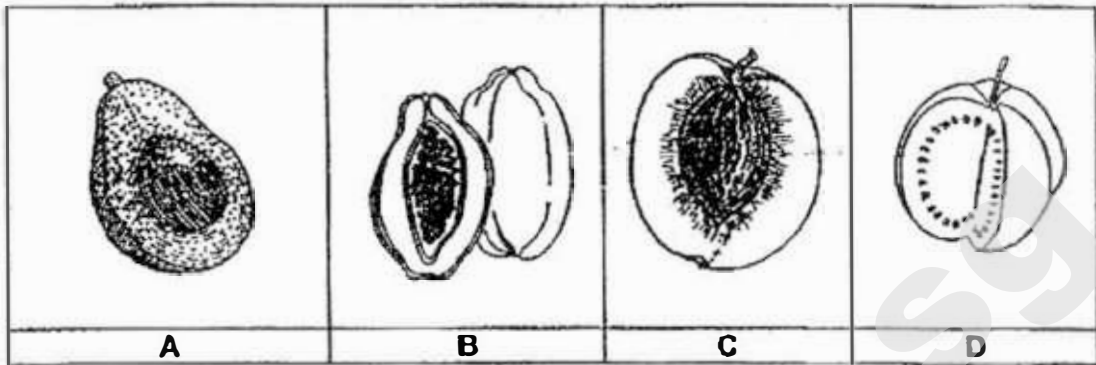

Based on the pictures above, which one of the following shows the correct classification?

	Fruits with many seeds	Fruits with one seed
(1)	A and B	C and D
(2)	A and C	B and D
(3)	B and D	A and C
(4)	B and C	A and D

3. Study the classification diagram below.

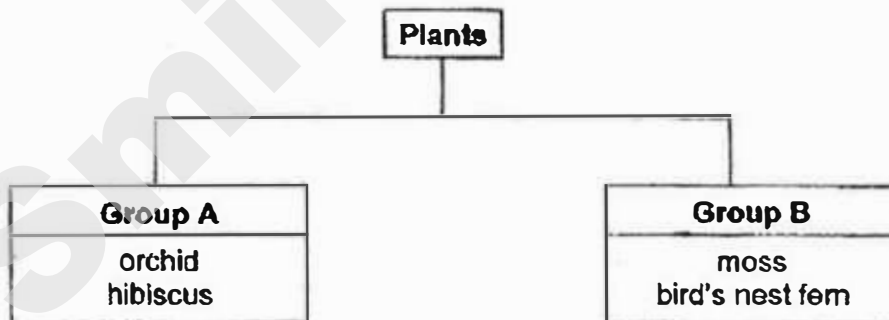

Which of the following shows the correct headings for Group A and B?

	Group A	Group B
(1)	Grow on land	Grow in water
(2)	Bear flowers	Do not bear flowers
(3)	Have a weak stem	Have a strong stem
(4)	Reproduce from spores	Reproduce from seeds

4. The following diagrams show animals A, B, C and D, not drawn to scale.

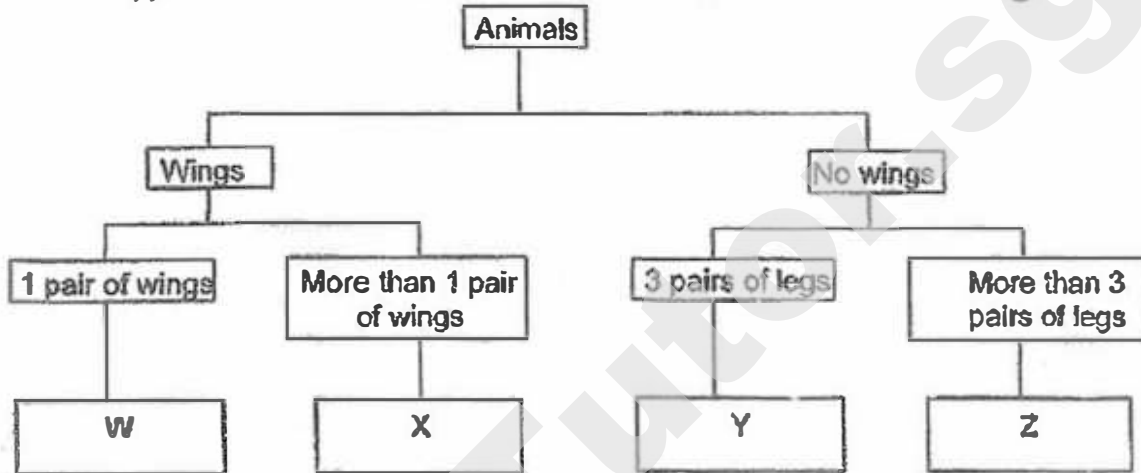
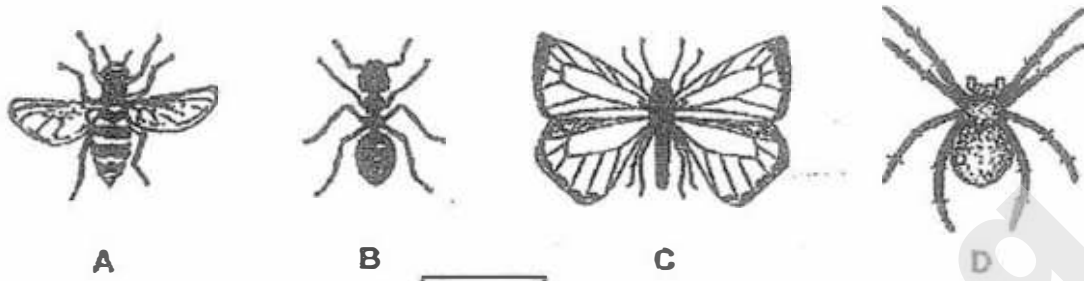

Which of the following shows the correct classification of animals A, B, C and D?

	W	X	Y	Z
(1)	D	B	C	A
(2)	C	A	D	B
(3)	B	D	A	C
(4)	A	C	B	D

5. Which of the following are characteristics of fungi?

- A They do not bear flowers.
- B They can only live in water.
- C They can make their own food.
- D They feed on organisms, dead or alive.

- (1) A and D only
- (2) A, C and D only
- (3) A, B and C only
- (4) B, C and D only

6. The diagram below shows the life cycle of a butterfly.

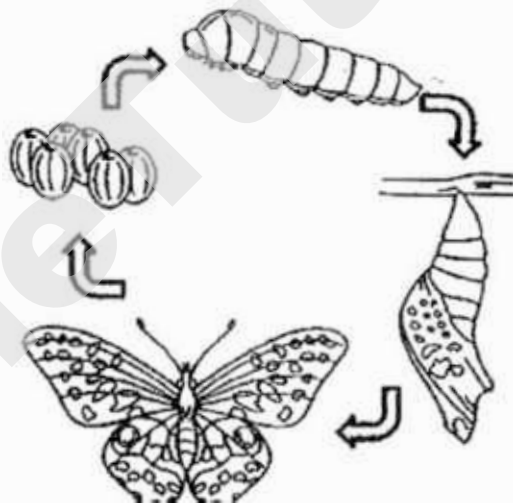

Which of the following statements describe(s) the animal in the adult and larval stage?

- A Both have wings.
- B Both live on land.
- C They resemble each other.
- D The animal moults in the larval stage but not in the adult stage.

- (1) D only
- (2) B and D only
- (3) C and D only
- (4) A, B and C only

7. The flow chart below is used to identify 3 pupils, Ali, Bala and Weiming based on their inherited characteristics.

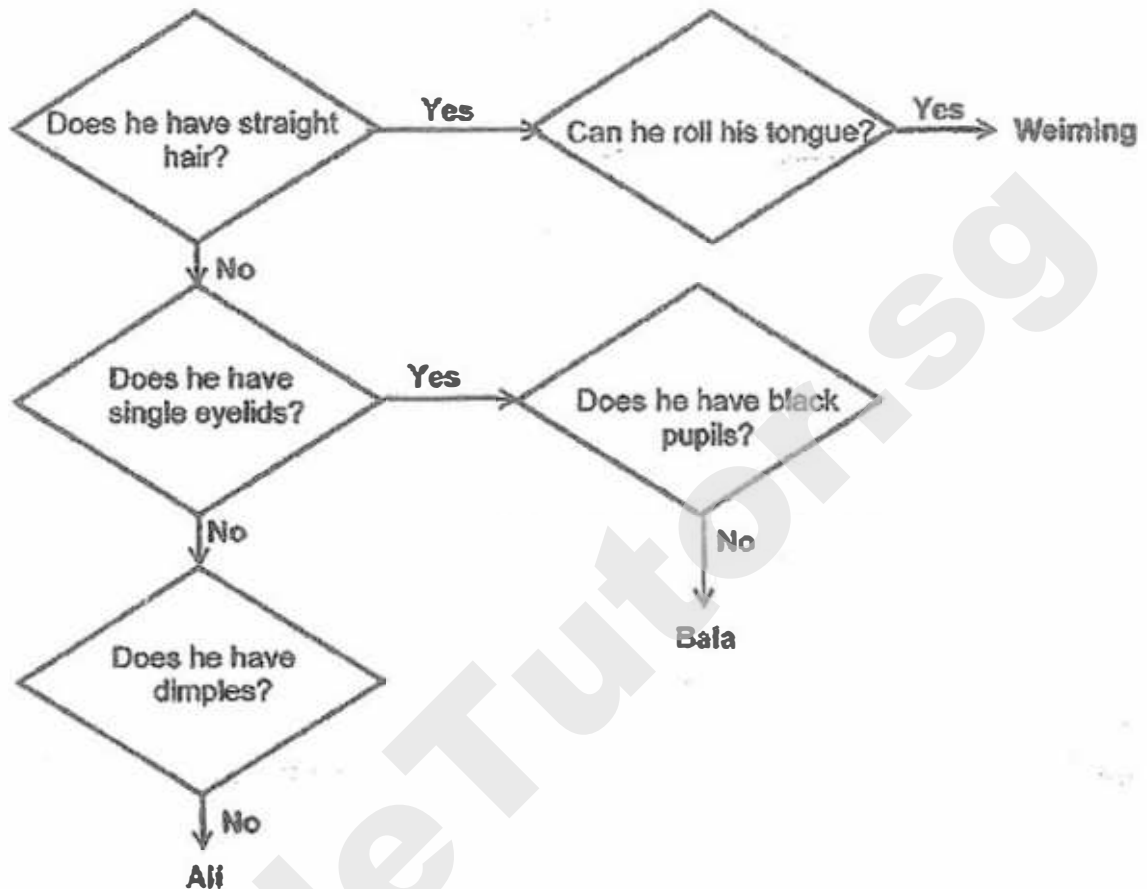

Based on the information above, which of the following statements is true?

- (1) Ali has curly hair and single eyelids.
- (2) Bala has black pupils and straight hair.
- (3) Ali has double eyelids but not Bala
- (4) Weiming has curly hair and cannot roll his tongue

8. David put four seeds, P, Q, R and S, from the same lady's finger plant under the conditions as shown in the table below.

A tick (✓) in the box indicates the conditions that are provided for the seed.

Seed	Conditions			
	Air	Light	Water	Temperature (°C)
P	✓		✓	31
Q	✓	✓		29
R	✓	✓	✓	35
S	✓		✓	85

Which of the following seed(s) will most likely germinate?

- (1) P only
- (2) P and R only
- (3) Q and S only
- (4) P, Q and S only

9. Which of the following statements about reproduction is not true?

- (1) Reproduction in human involves cell division.
- (2) Animals reproduce to ensure the continuity of their kind.
- (3) Sexual reproduction involves male and female sex cells.
- (4) Sexual reproduction only happens in animals and not plants.

10. The diagrams below show a plant and human reproductive system.

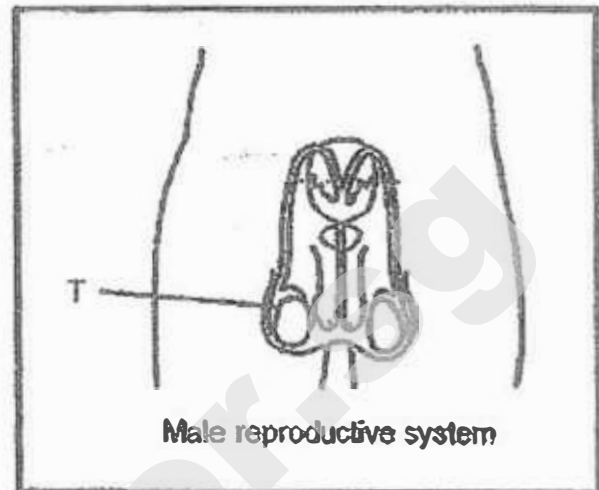
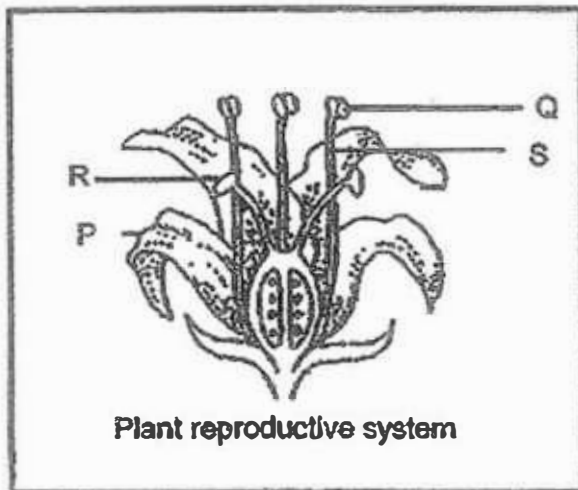

Which part, P, Q, R or S, has the same function as Part T?

- (1) P
- (2) Q
- (3) R
- (4) S

11. The table below shows the physical characteristics of Tommy, his sister and his parents, Mr and Mrs Ho.

	Physical Characteristics			
	Hair length	Ability to roll tongue	Eyelids	Earlobes
Mr Ho	Short	No	Double	Attached
Mrs Ho	Long	Yes	Single	Detached
Tommy	Short	Yes	Double	Detached
Tommy's Sister	Short	No	Double	Detached

Based on the table above, which of the following statements are correct?

- A Tommy inherited the ability to roll tongue from his parent.
- B Tommy inherited the detached earlobes from his mother.
- C Mr Ho passed down the short hair length to both children.
- D Only Tommy inherited the double eyelid from his father.

- 1) A and B only
- 2) B and C only
- 3) A, B and C only
- 4) A, B and D only

12. The diagram below shows the cross section of a flower.

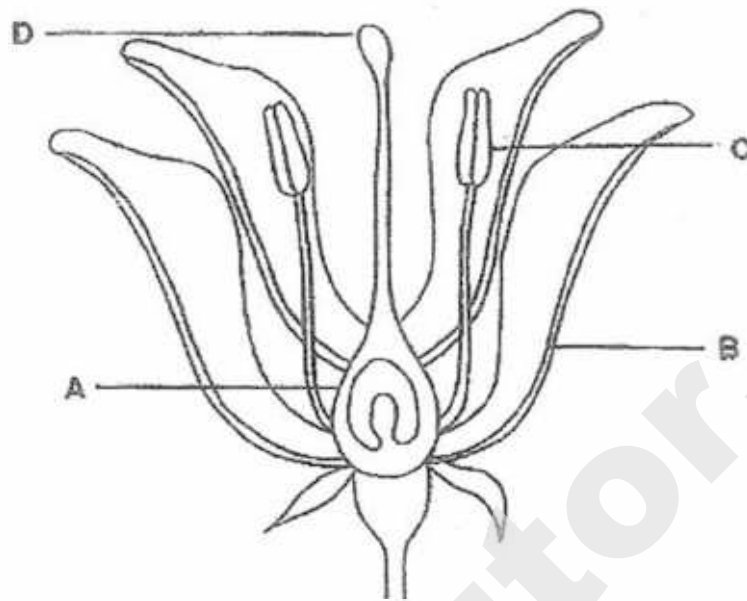

Which part of the flower becomes a fruit after fertilisation has taken place?

- (1) A
 - (2) B
 - (3) C
 - (4) D
13. Jenny saw Flower X during a field trip and concluded that it was pollinated by wind. Which of the following features are likely to have helped her arrive at the conclusion?
- A The flowers are large.
 - B The flowers are red in colour.
 - C The flowers have no nectar and fragrance.
 - D The filaments are long and thin and are hanging out of the flowers.
- (1) A and B only
 - (2) C and D only
 - (3) A, B and C only
 - (4) B, C and D only

14. The drawing below shows how three types of plants were found growing on parts of an island.

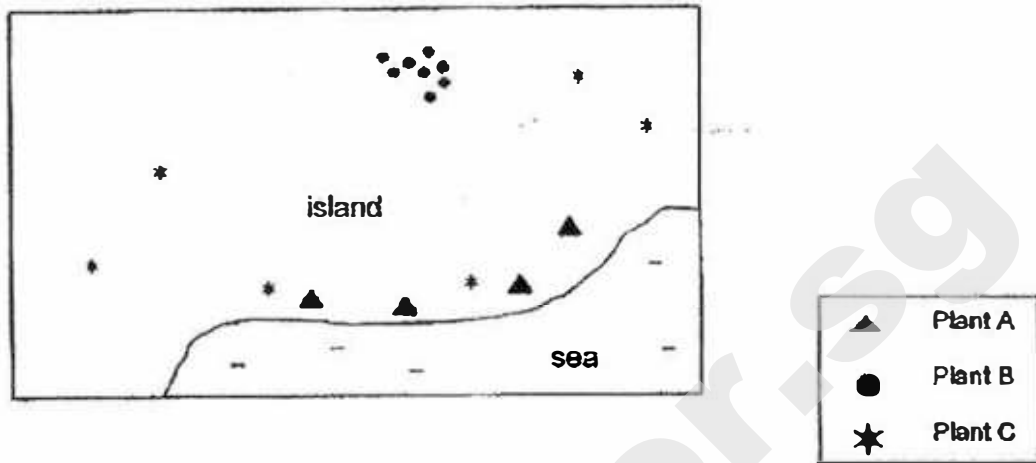

After two years, the plants were found growing on different parts of the island as shown in the diagram below.

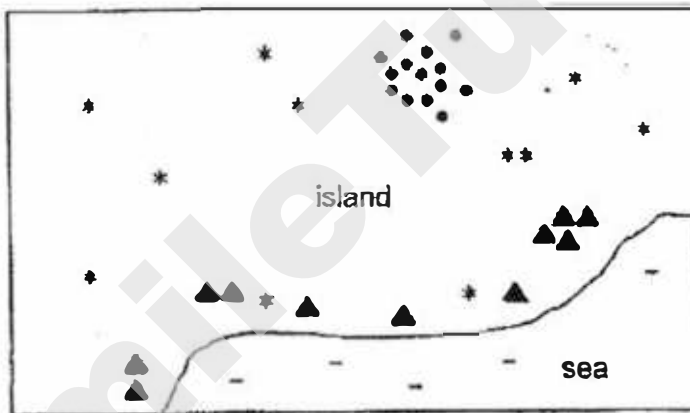

Which of the following best describes the characteristics of the fruit / seed of each type of plant?

	▲	●	★
(1)	Fibrous husk	Have hooks	Dry and light
(2)	Have hooks	Dry and light	Fibrous husk
(3)	Dry and light	Fibrous husk	Pod-like fruits
(4)	Fibrous husk	Pod-like fruits	Dry and light

15. The diagram below shows a cell with its different parts labelled A, B, C, D and E.

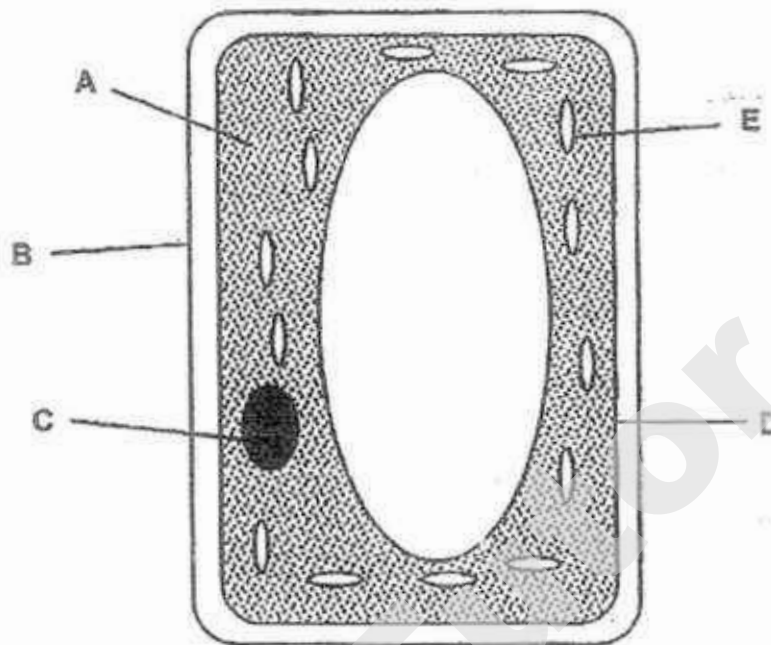

Which of the following identifies the parts of the cell correctly?

	Traps light energy	Controls the entry of substances into the cell	Also found in animal cells
(1)	C	D	B, D, E
(2)	A	B	C, D, E
(3)	E	B	A, B, C
(4)	E	D	A, C, D

16. The diagram below shows two animal cells, A and B, before an experiment.

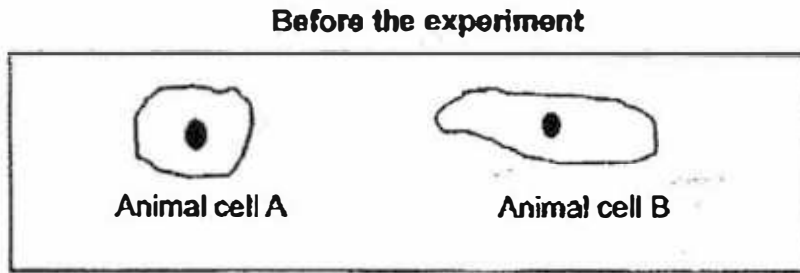

Animal cells, A and B, were then placed in a container of water containing the same amount of dissolved substances, X and Y.

The diagram below shows how cells, A and B, look like after the experiment.

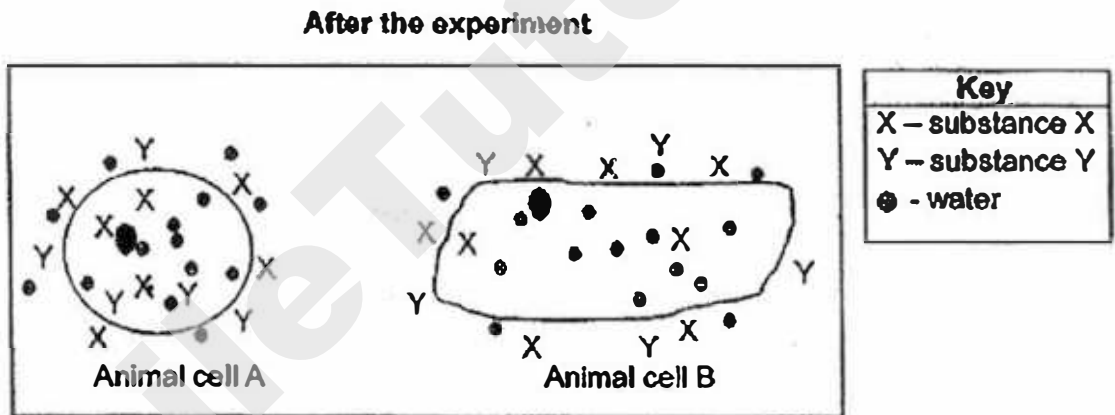

Which one of the following observations about the cells is/are correct?

- A Water can enter both cells A and B.
- B Substance Y is unable to enter cell B.
- C Cell A does not allow any substance to enter it.

- (1) A only
- (2) B only
- (3) A and B only
- (4) A, B and C

17. Steven's diving watch strap is made of material H as shown below.



Which of the following propertie(s) is/are important when choosing material H to make the diving watch strap?

- A Flexibility
- B Float in water
- C Waterproof
- D Allows light to pass through

- (1) C only
- (2) A and C only
- (3) C and D only
- (4) A, B and D only

18. John placed two balls, A and B, of the same size but made of different materials, into two containers of water as shown below.

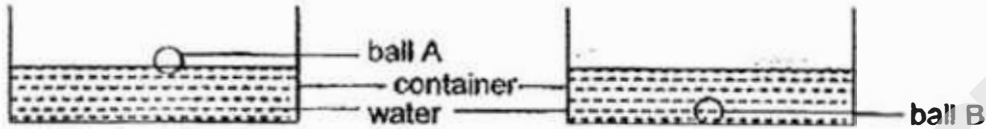

He replaced the water with the same amount of liquid M and placed balls A and B into the two containers as shown below.

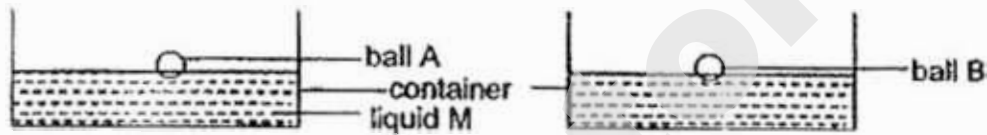

Based on the information above, which of the following statement(s) is/are definitely correct?

- A Both balls are waterproof.
 - B Ball A is stronger than ball B.
 - C Ball A sinks in water but floats on liquid M.
 - D Ball B sinks in water but floats on liquid M.
- (1) D only
(2) A and B only
(3) B and C only
(4) C and D only

19. Study the flow chart shown below.

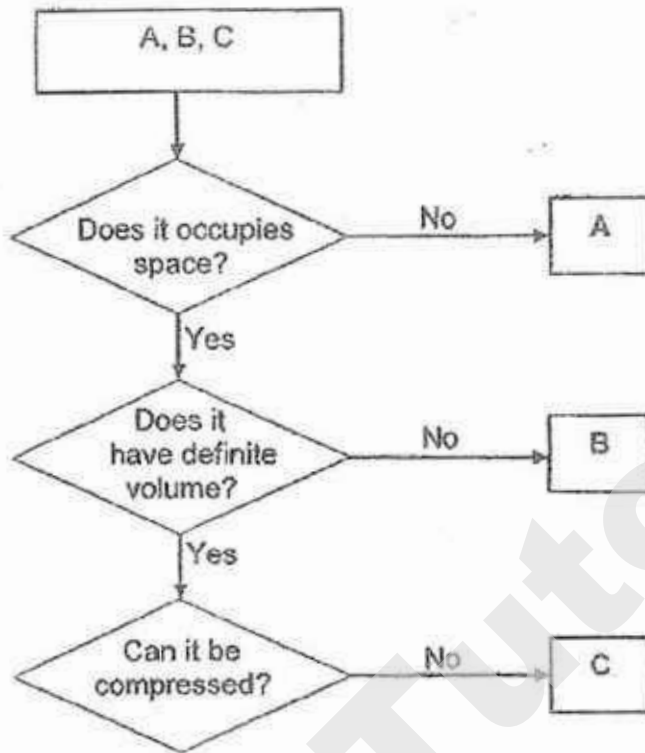

Which of the following are most likely to be A, B and C?

	A	B	C
(1)	sound	oxygen	iron ball
(2)	shadow	lemon juice	stone
(3)	fire	brick	water
(4)	air	feather	rubber band

20. The information of substance A is shown below.

- It boils at 280 °C.
- It is a solid at 30 °C.
- It turns into a liquid at 44 °C.

Based on the information above, which of the following statement(s) about substance A is/are correct?

- A It freezes at 150 °C.
 B It is a gas at 320 °C.
 C It remains at the liquid state at 120 °C.

- (1) A only
 (2) B only
 (3) B and C only
 (4) A and C only

21. The diagram below represents the changes of state in a water cycle.

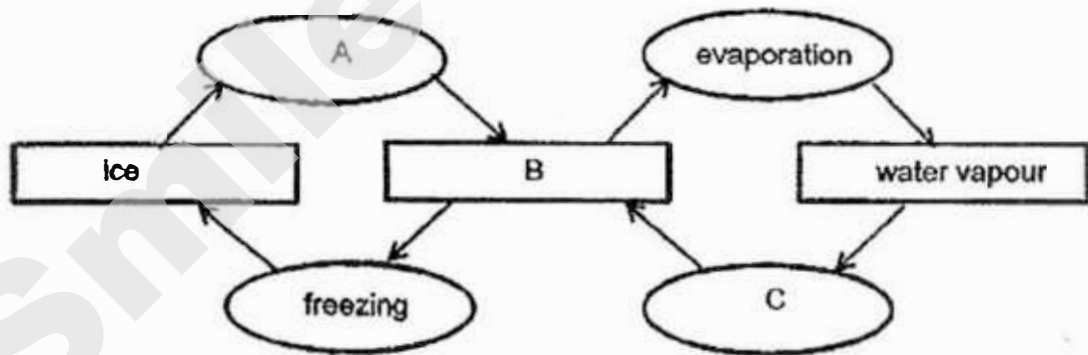

Which one of the following correctly describes A, B and C?

	A	B	C
(1)	condensation	water	boiling
(2)	condensation	water	evaporation
(3)	melting	water vapour	condensation
(4)	melting	water	condensation

For questions 22 and 23, refer to the diagram below.

The graph below shows the changes in the temperature of water at 100°C which was left on the table over a period of time.

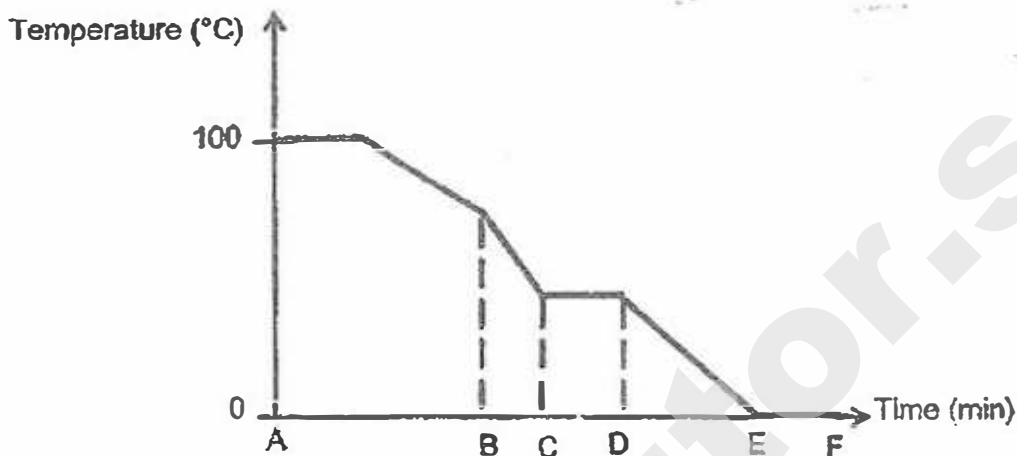

22. Which of the following statements is correct?

- (1) Evaporation takes place at A.
- (2) Water is placed in the freezer at D.
- (3) A change of state of water takes place at C.
- (4) Water gained heat from the surroundings at E.

23. Which of the following correctly shows the state of water at A, C, D and E?

	A	C	D	E
(1)	liquid	liquid	gas	liquid
(2)	gas	liquid	liquid	solid
(3)	gas	gas	liquid	liquid
(4)	liquid	liquid	solid	solid

24. Alice placed some freshly baked cookies in a glass jar and covered it with a lid as shown in the diagram below.

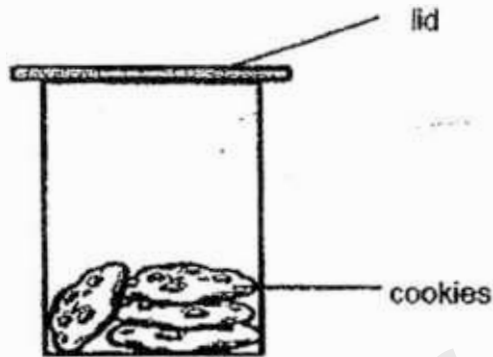

After 20 minutes, she removed the lid and found some cookies were damp.

Which of the following correctly explains her observation?

- (1) Water vapour in the jar condensed on the cookies.
- (2) The surrounding air in the jar condensed onto the cookies.
- (3) Water vapour in the surrounding air condensed the cookies.
- (4) Steam from the cookies evaporated and condensed on the cookies.

25. Study the diagram below.

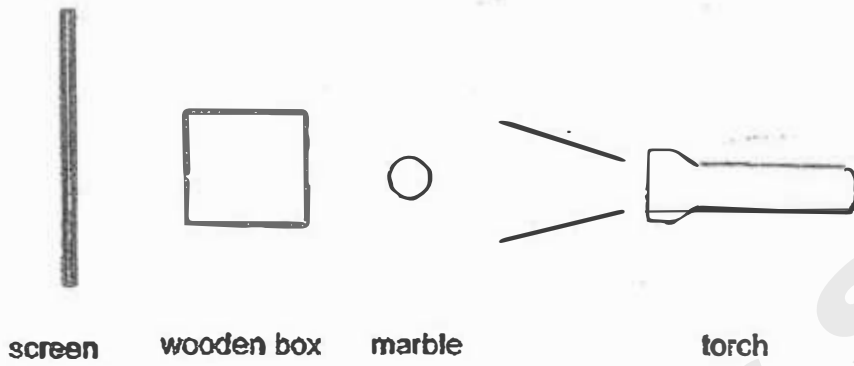

Which of the following shadows will be observed on the screen?

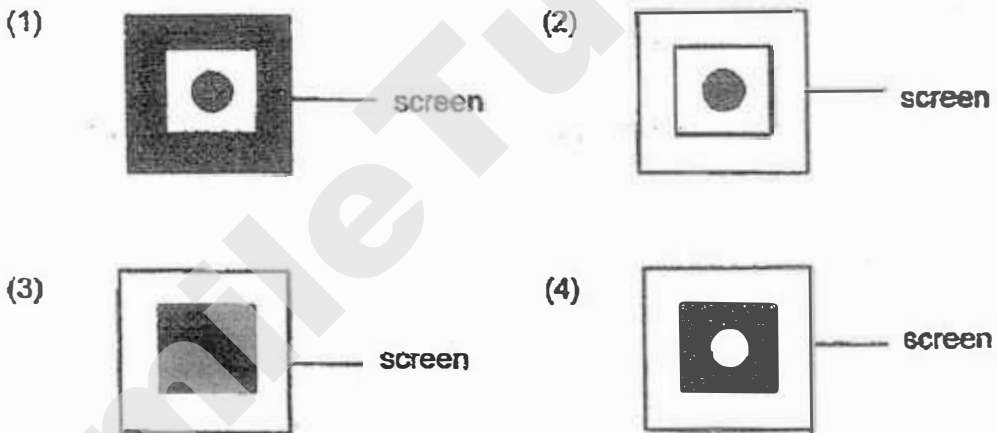

26. The diagram below shows a connection of pipes. Different materials are placed inside the pipes.

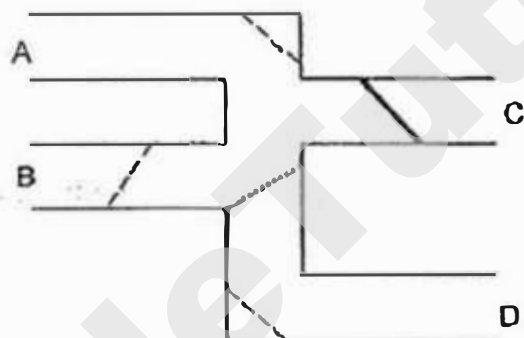
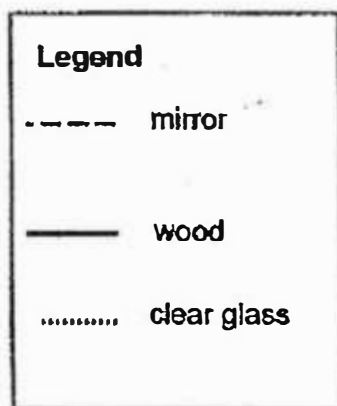





In order to see an object through the pipes, where should the eye and the object be placed?

	Eye at position	Object at position
(1)	A	C
(2)	D	A
(3)	B	D
(4)	C	B

27. A bimetallic strip is made of two different metals. The diagram below shows the observation of the two bimetallic strips, X and Y, after being heated for five minutes.



Bimetallic strips	Before heating	After heating
X		
Y		

Based on the information above, which of the following statements is most likely to be correct?

- (1) Metal A expands the least.
- (2) Metal B expands the most.
- (3) Metal B and C have the same rate of expansion.
- (4) Metal A expands less than metal C but more than B.

28. Fatimah put ice cubes of equal volume into four similar boxes, A, B, C and D. The boxes were made of different materials. She left the ice cubes in the boxes for twenty minutes and measured the amount of water collected in each box. Then she recorded her findings in the graph below.

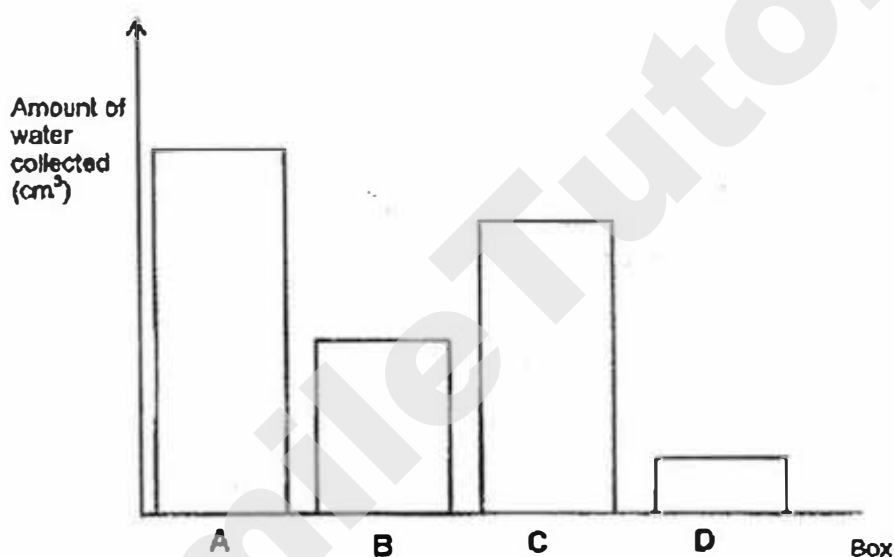
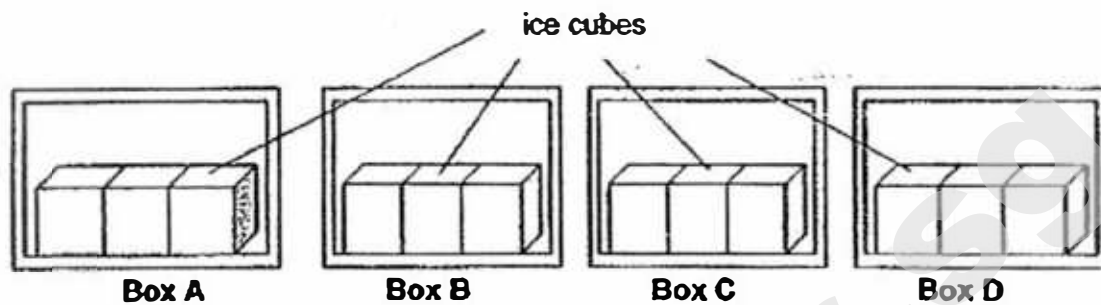

Based on the results above, which one of the following boxes should Fatimah use to keep her cans of soya bean drinks cold for the longest time?

- (1) A
- (2) B
- (3) C
- (4) D

Name: _____ Index No: _____ Class: P5 _____

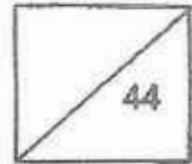

SECTION B (44 marks)

For questions 29 to 41, write your answers clearly in the spaces provided.
The number of marks is shown in brackets [] at the end of each question or part question.

29. The table below shows the characteristics of four things, A, B, C and D.
A tick (✓) indicates the presence of the characteristics.

Thing	Able to reproduce	Able to decrease in size	Able to produce its own food	Able to move from place to place
A		✓		✓
B	✓		✓	
C	✓			✓
D	✓		✓	

- (a) Which thing(s) above is/are definitely plant(s)? Give a reason for your answer. [1]

- (b) All commented that A and C are non-living things. Do you agree? Explain your answer clearly. [2]

SCORE	
-------	--

30. The table below shows the characteristics of the stages in the life cycles of four animals, A, B, C and D. A tick (✓) indicates the presence of the characteristics.

Characteristic	Animal A	Animal B	Animal C	Animal D
It lays eggs in water		✓		✓
The young lives in water.	✓			✓
It has 3-stage life cycle.	✓	✓	✓	

Based on the information in the table above, answer part (a) and (b).

- (a) State one difference between Animals A and D.
[1]

- (b) Which of the following animals, A, B, C or D, are most likely to be a chicken and a mosquito? Write the letters, A, B, C or D in the correct boxes below. [1]

	Chicken	Mosquito
Animal		

- (c) Give a reason why it is easier to get rid of mosquitoes in its egg stage rather than its adult stage. [1]

SCORE	3
-------	---

31. John carried out an experiment on three seedlings, P, Q and R. He removed half of Part X from seedling Q and the entire Part X from seedling R as shown below.

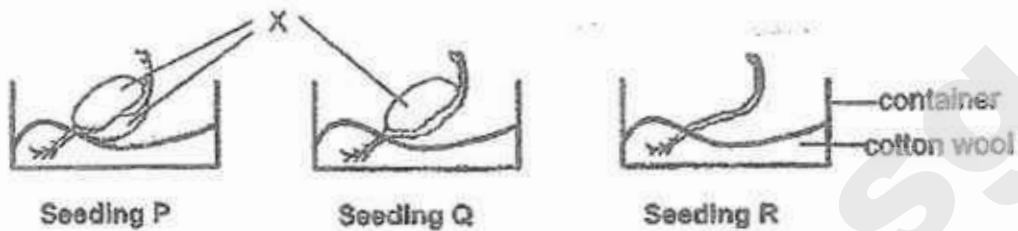

He placed each seedling in a container on a wet cotton wool. Then he placed the containers on a table in the science laboratory and observed their growth over a period of two weeks.

- (a) Name Part X. [1]

- (b) Which seedling(s) will continue to grow? Explain your answer. [1]

- (c) Explain why John did not place all the containers under direct sunlight during the first few days of the experiment. [2]

SCORE	4
-------	---

32. The diagram below shows the female reproductive system.

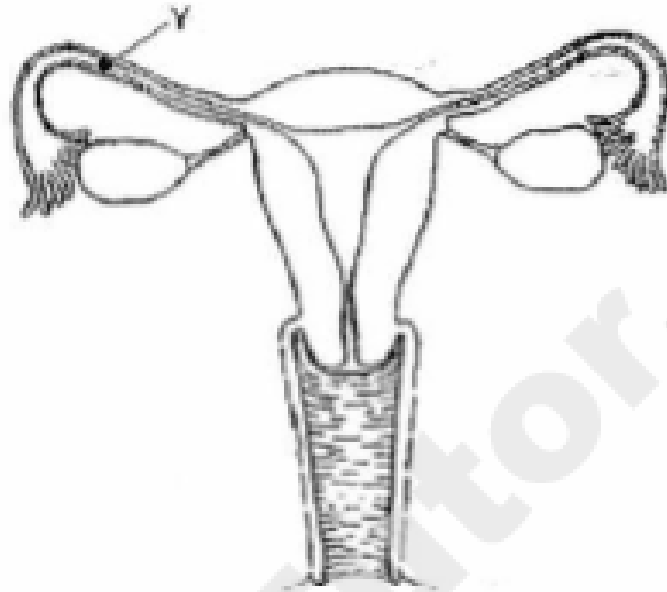

- (a) In the diagram above, label part X where a fertilised egg will develop. [1]
- (b) Ruth was told that there was a complete blockage at part Y of her reproductive system as shown in the diagram above. Can fertilisation still take place? Explain your answer. [2]

SCORE	3
-------	---

33. Sarah wanted to find out if the distance travelled by the fruit is affected by the length of its structure, labelled Y, when dropped from a height, h .

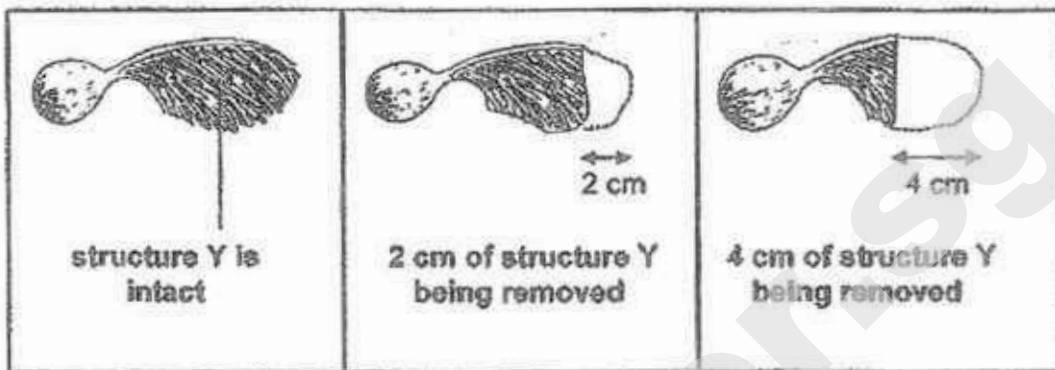

First, she dropped the fruit, with structure Y intact, from a height, h , and measured the distance travelled by it. She repeated the experiment twice by using the same fruit, first with 2 cm of structure Y removed and finally with 4 cm of structure Y removed.



She recorded the distance travelled by the fruit in the table below.

Length of structure Y removed from the fruit (cm)	Distance travelled by the fruit (cm)
0	110
2	80
4	20

Continue on the next page

Continued from previous page

- (a) Based on the information above, name the method of seed dispersal of the fruit. [1]

- (b) Based on the information above, what is the relationship between the distance travelled by the fruit and the length of structure Y? [1]

- (c) Sarah removed the whole of structure Y from the fruit as shown below.



with structure Y removed

- What would most likely be the distance travelled by the fruit when dropped from the same height? Explain your answer clearly. [2]

- (d) Explain why plants need to disperse their seeds to prevent overcrowding. [1]

SCORE	5
-------	---

34. Kim Seng observed 3 types of cells under the microscope. He recorded his observations in the table below. A tick (✓) indicates the presence of the cell parts.

Cell Part	Cell A	Cell B	Cell C
Nucleus	✓	✓	✓
Cell Wall		✓	
Chloroplast	✓		
Cell Membrane	✓	✓	✓

- (a) Kim Seng made a mistake in his recording. Which cell, A, B or C, did he most likely record wrongly? Give a reason for your answer. [1]

- (b) Which cell is most likely to be taken from the roots of a plant? Give a reason for your answer. [1]

35. Joe set up an experiment to find out the strength of materials A, B, C and D. He clamped both ends of material A to a support and gently released a 50-kg load from the height as shown in the diagram below. He repeated the experiment by replacing the material and then recorded his observations.

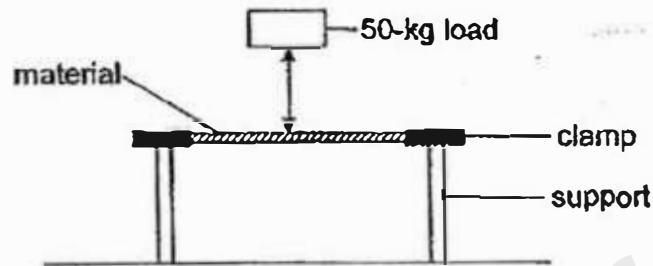

The table below shows his observations.

Material	Observations of the material
A	break into two pieces
B	fine cracks
C	no cracks
D	break into a few pieces

Based on the information given, answer the following questions.

- (a) Which type of materials, A, B, C or D, is most suitable to make into a chair for an adult? Give a reason for your answer. [1]

Continue on the next page

SCORE	1
-------	---

Continued from previous page

- (b) Other than the variables given in the question, state another two variables that should be kept the same to ensure a fair test. [2]

Variable 1	
Variable 2	

SCORE	
-------	---

36. Irene measured the mass of a deflated and inflated balloon and recorded her results in the table below.

Balloon	Mass (g)
Deflated	1.9
Inflated	5.4

- (a) State the property of matter that explains why there is a difference between the mass of the deflated and inflated balloon. [1]

Irene folded her quilt blanket and placed it into a storage bag as shown in diagram 1 below. She weighed the blanket together with the storage bag.

Then she used a vacuum pump to remove all the air from the storage bag as shown in diagram 3. She weighed the blanket together with the storage bag shown in diagram 4.

Diagram 1



Diagram 2



Diagram 4

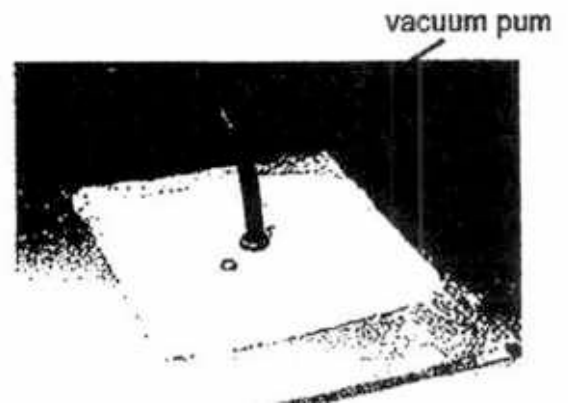

Diagram 3

Continue on the next page

SCORE	1
-------	---

Continued from previous page

- (b) Will the mass of the storage bag and its content shown in diagram 4 be more than, less than or the same, as the one shown in diagram 2? Explain your answer clearly. [2]

SCORE	
-------	---

37. Alex poured some hot water into a container. He observed some mist was formed in the container above the hot water.

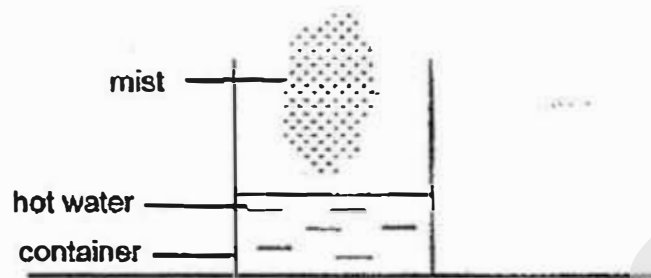

- (a) State the process and the change of state of water when the mist was formed. [2]

Process	Change of state of water
	From _____ to _____

- (b) List two ways to reduce the amount of mist in the container. [2]

(i) _____

(ii) _____

SCORE	4
-------	---

38. Bala poured 50 ml of water into 2 containers, A and B, as shown in the diagram below.

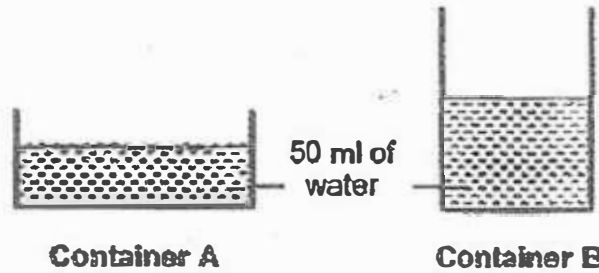

He placed the two containers next to an open window and measured the time taken for the water in each container to evaporate completely. His results are shown below.

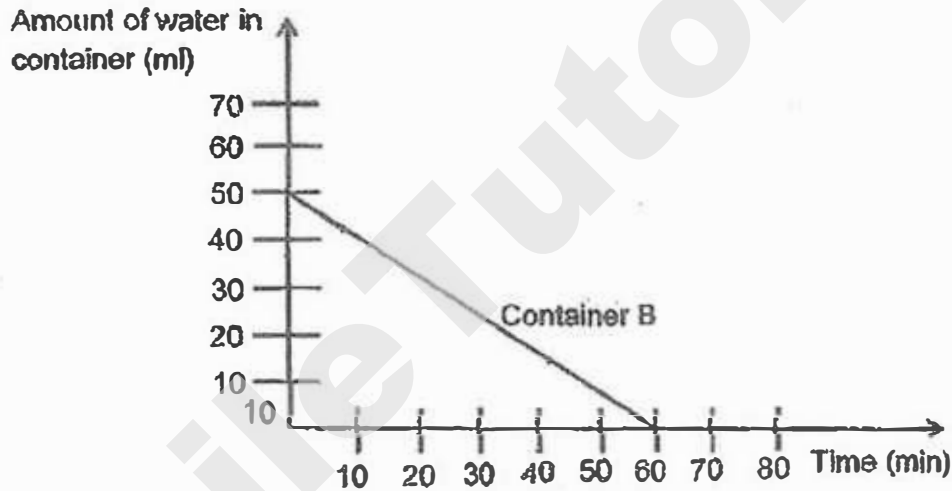

- (a) **Draw and label** the line graph for container A in the graph above. [1]

- (b) Explain your answer in (a). [2]

- (c) Without changing containers A and B, suggest two ways to increase the rate of evaporation of the water in containers A and B. [2]

SCORE	5
-------	---

39. Ahmad used different materials to cut out three different shapes; a triangle, a square with the middle section being cut out and a circle as shown in the diagram below.

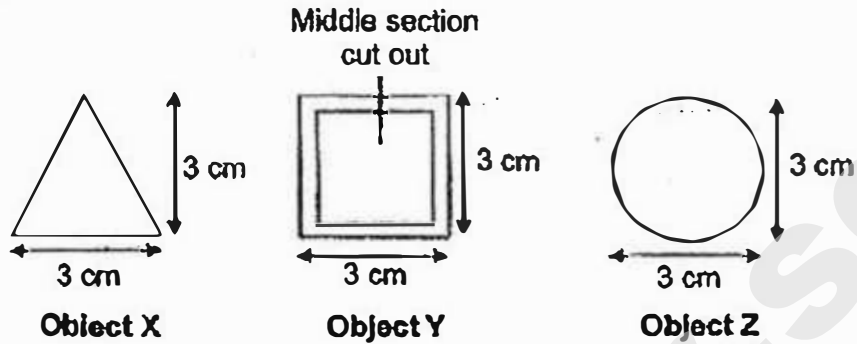

He arranged the objects as shown in the diagram below.

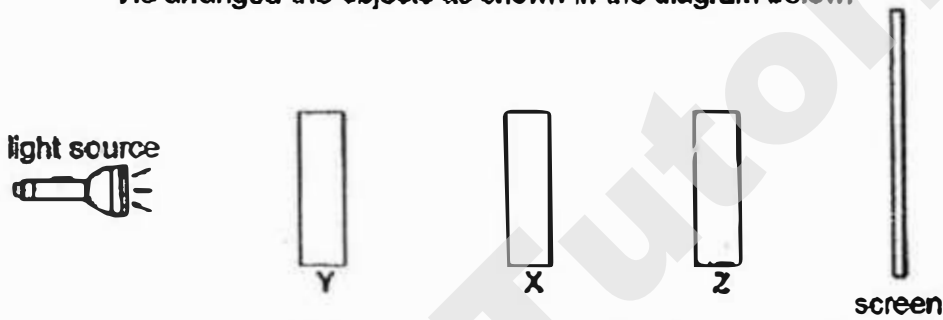

The following diagram shows the shadow that was cast on the screen.



Based on the information above, put a tick (✓) in the correct box against each object. [3]

Objects	Transparency of the materials		
	Allow most light to pass through	Allow some light to pass through	Does not allow light to pass through
X			
Y			
Z			

SCORE	3
-------	---

40. Shi Ling conducted an experiment as shown below. She observed that the water level in the glass tube increase after the water in the flask had been heated for 10 minutes.

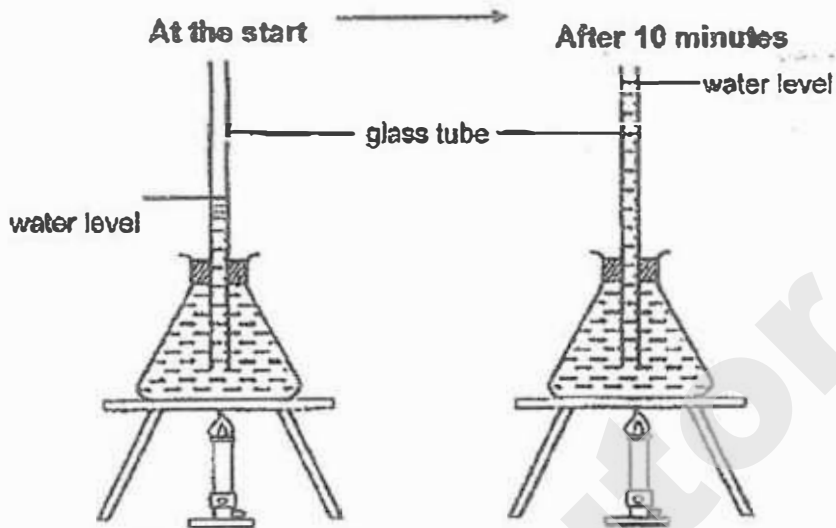

- (a) Give a reason why the water level rose in the glass tube.

[1]

The diagram below show some bottled drinks.

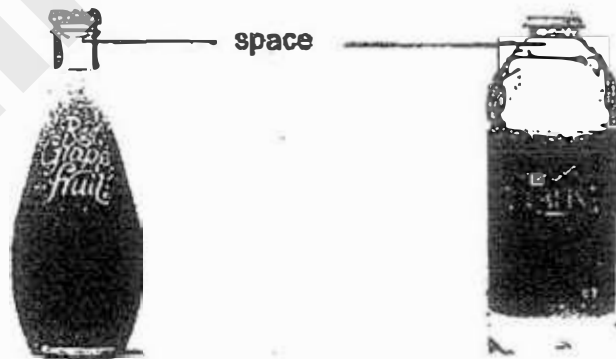

- (b) Explain why the drinks are often not filled to the brim in bottles during packaging.

[2]

SCORE	3
-------	---

41. Sally put a block of ice in Bag Y and ice cubes in Bag Z. The two bags of ice are of the same mass. She left the two bags on a table in the kitchen.

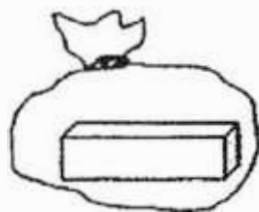

Bag Y



Bag Z

The table below shows the time taken for the ice in each bag to melt completely.

Ice in	Time taken for the ice to melt completely
Bag Y	15 min 20 s
Bag Z	7 min 15 s

- (a). Explain why the ice in Bag Z took a shorter time to melt completely. [1]

Sally wanted to use a cooler bag to keep her cold drinks which she would be bringing for her picnic in a park.



cooler bag

- (b) Which bag of ice, Y or Z, should Sally put in her cooler bag? Explain your answer. [2]

SCORE	3
-------	---

EXAM PAPER 2017 (P5)

SCHOOL : RAFFLES GIRLS'

SUBJECT : SCIENCE

TERM : SA1

Q1	Q2	Q3	Q4	Q5	Q6	Q7	Q8	Q9	Q10
2	3	2	4	1	2	3	2	4	2
Q11	Q12	Q13	Q14	Q15	Q16	Q17	Q18	Q19	Q20
1	1	2	4	4	3	2	1	1	3
Q21	Q22	Q23	Q24	Q25	Q26	Q27	Q28		
4	2	2	1	3	2	2	4		

29)a) Things B and D. Plants are able to reproduce, unable to decrease in size, able to produce its own food and unable to move from place to place like Things B and D.

b) No, I disagree. A is a non-living thing as it cannot reproduce and make its own food. C is a living thing as it can reproduce and move from place to place.

30)a) Animal A does not lay eggs in water but Animal D lay eggs in water.

b) C D

c) Mosquitoes in its egg stage lives in water and does not feed or move but mosquitoes in its adult stage are small and can fly, making it more difficult to be get rid of.

31)a)The seed leaf.

b)Seedling P and Q. Seedlings P and Q still have their seed leaves to provide them with stored food for growth until they had grown true leaves to make food by photosynthesis.

c)As the seedling has not developed any leaves yet, it does not need sunlight to make food as it depends on the seed leaves for food.

32)a)

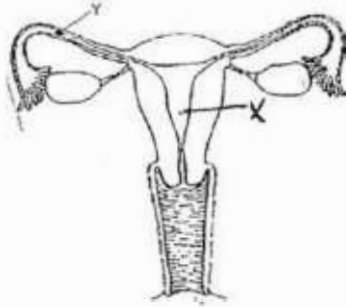

b)Yes. Sperm can still reach her mature egg released by the other ovary to fuse with her egg, allowing fertilization to take place.

33)a)The fruit is dispersed by wind.

b)The longer the length of structure Y, the greater the distance travelled by the fruit.

c)10cm. There is an absence of wing-like structure to help it stay afloat in the air for a longer period of time and to be blown by the wind to a further distance.

d)Plants need to disperse their seeds away from their parent plant to prevent overcrowding to reduce competition for light, nutrients, water and space.

34)a)Cell A, It is a plant cell as it has chloroplasts therefore it should also have a cell wall.

b)Cell B. It has a cell wall but no chloroplast.

35) a) Material C. Material C does not have any cracks or broke when a 50kf load was released, indicating that it was the strongest material. Since a chair needs to be strong to hold an adult's weight, Material C is most suitable to make into a chair.

b) 1) The thickness of the materials, A, B, C, D.

2) The distance between the two supports.

36) a) Air has mass.

b) The mass of the storage bag with its content shown in Diagram 4 would be less than the one shown in Diagram 2. Air occupied space in the storage bag and has mass. Hence, when she used the vacuum pump to remove all the air from the storage bag, the mass would decrease.

37) a)

Process	Change of state of water
Condensation	From Gas to Liquid

b) i) Change the water in the container to a lower temperature than the hot water.

ii) Higher temperature of the surroundings.

38) a)

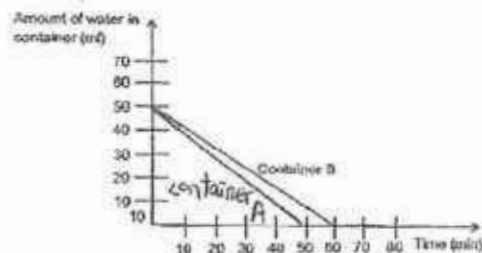

38)b)The water in container A had a greater exposed surface area than the water in Container B, resulting in a greater rate of evaporation than the water in Container B.

c)Increase the temperature of the surroundings or put a fan near container A and B.

39)

X			✓
Y			✓
Z	✓		

40)a)The water in the flask gained heat from the flame, expanded and occupied more space, causing the water level in the glass tube to rise.

b)The drinks in the bottle would eventually gain heat from the surrounding air, expand and occupy more space. Hence, the drinks are often not filled to the brim to prevent the bottles from cracking when the drinks expand.

41)a)The ice in bag Z took a shorter time to melt completely in due to the greater exposed surface area, which leads to a greater rate of heat gain.

b)She should use Bag Y. It is because with a smaller exposed surface area, the rate of heat gain would be slower, and the ice would take a longer time to melt. Hence, the cold drinks can be kept cold for a longer period of time.

**SEMESTRAL ASSESSMENT 1 /
2017 PRIMARY 5**

STANDARD SCIENCE

(BOOKLET A)

Name : _____ ()

Date : 9 May 2017

Class : P5 _____

Total Time for Booklet A & Booklet B : 1 hour 45 min

INSTRUCTIONS TO CANDIDATES

1. Write your name, index number and class in the space above.
2. Do not turn over this page until you are told to do so.
3. Follow all instructions carefully.
4. Answer all questions.
5. For Section A, shade your answers for questions 1 to 28 in the Optical Answer Sheet (OAS) provided.
6. For Section B, write your answers for questions 29 to 40 in the space provided in the booklet.
7. The total marks for Booklet A is 56 marks.

Section A (56 marks)

For each question 1 to 28, four options are given. One of them is the correct answer. Make your choice (1, 2, 3 or 4). Shade the oval (1, 2, 3 or 4) on the Optical Answer Sheet.

1. The diagram below shows the changes of the states of water.

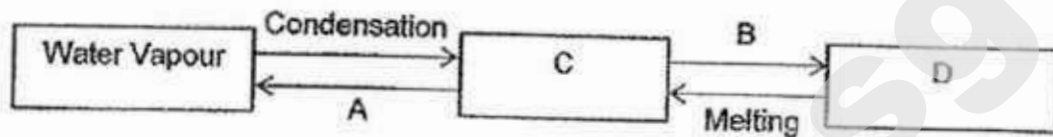

Based on the diagram above, which one of the following correctly represents A, B, C and D?

	A	B	C	D
(1)	Freezing	Evaporation	Ice	Water
(2)	Evaporation	Boiling	Water	Steam
(3)	Evaporation	Freezing	Water	Ice
(4)	Boiling	Freezing	Steam	Ice

()

2. An experiment was set up to investigate the factors that affect the rate of condensation of water vapour.

The same amount of water at 5°C or 90°C was poured into similar containers which were covered with similar plastic sheets.

Which one of the following would result in no water being collected in the cup?

(1)

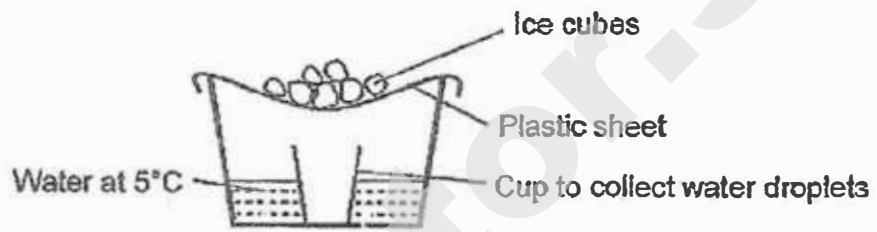

(2)

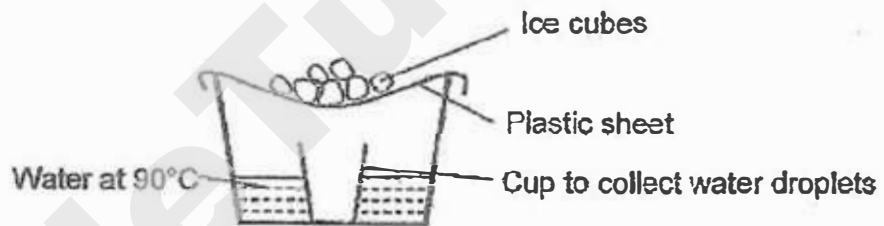

(3)



(4)

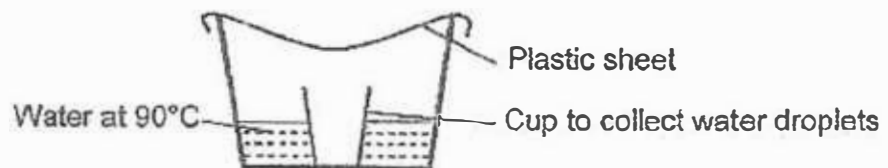

()

3. Tommy heated some water in a beaker until it boiled. It was then left in the kitchen to cool. He measured the temperature of the water during the process and plotted the graph shown below.

Temperature ($^{\circ}\text{C}$)

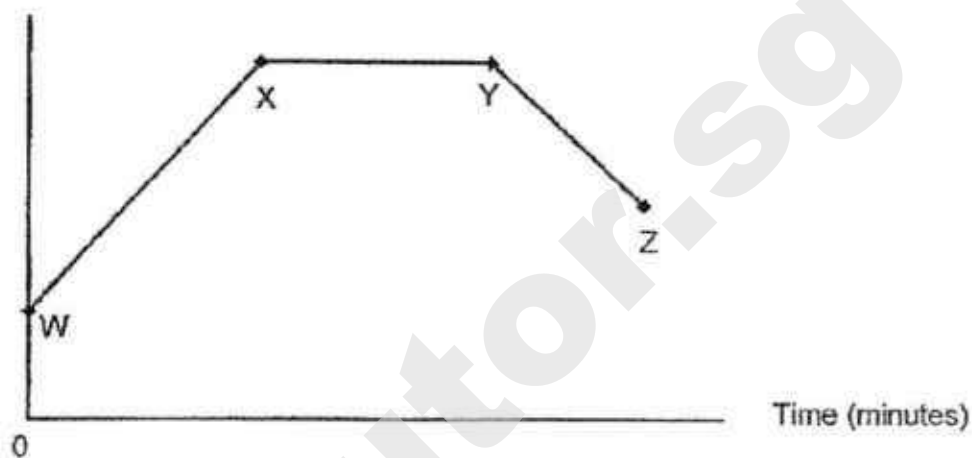

He then made the following statements.

- A: At W, freezing took place.
- B: There is heat loss from Y to Z.
- C: There is no heat gain from X to Y.
- D: Evaporation took place from W to Z.

Which of the following statement(s) above is/are false?

- (1) A and C only
- (2) C and D only
- (3) B and C only
- (4) A, C and D only

()

4. Mary placed the stem of a plant in a container of water with red food colouring. After some time, she cut a section of the stem.

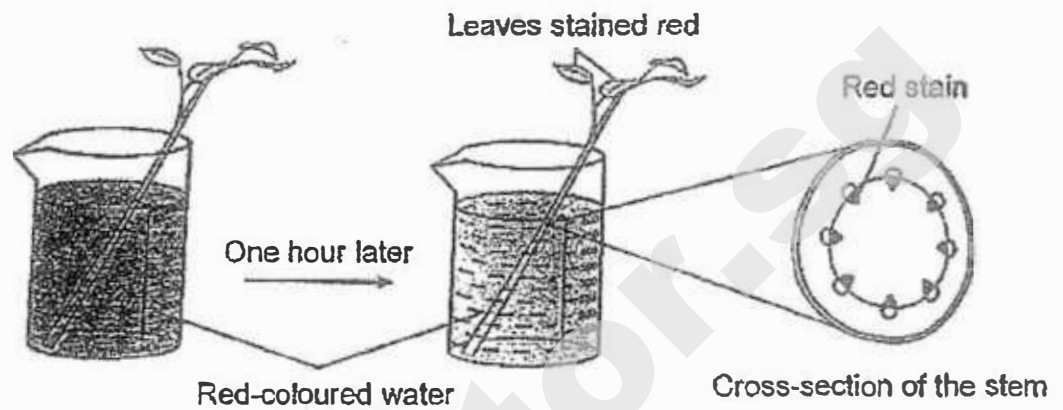

Mary observed the leaves and the stains on the cross-section of the stem and wrote three statements.

What of the following statement(s) is/are correct?

- A: The stem has tubes that transport the water downwards.
B: The colouring on the leaves comes from the red-coloured water.
C: The part of the stem, which is coloured red, transports food to the leaves.

- (1) A only
(2) B only
(3) C only
(4) A, B and C

()

5. Which of the statements below are not functions of Part X?

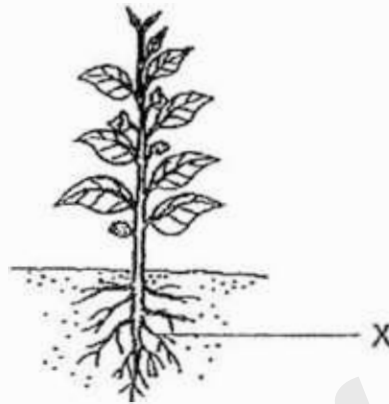

- A. It helps the plant to absorb water.
- B. It holds the plant firmly to the ground.
- C. It supports the plant and holds it upright.
- D. It allows the exchange of gases to take place.
- E. It transports food from the leaves to other parts of the plant.

- (1) A, B and D only
- (2) B, C and E only
- (3) B, D and E only
- (4) C, D and E only

()

6. Study the cell below. One part of the cell has been removed.

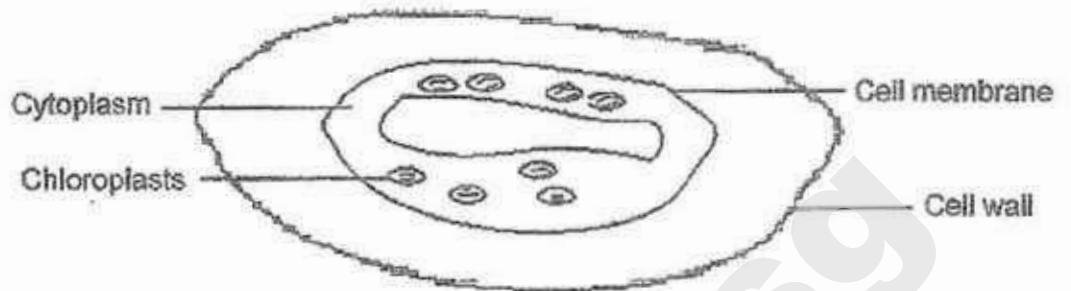

What is the function of the part that has been removed?

- (1) It supports the cell and gives it a regular shape.
- (2) It captures sunlight which plants use to make food.
- (3) It allows the chloroplasts to move around easily within the cell.
- (4) It contains the genetic information that is passed on from parents to young.

7. Gary placed a seed into a container of soil as shown below. He poured water on the soil daily.

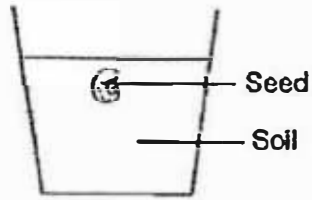

Which one of the following diagrams shows what Gary would observe after some time?

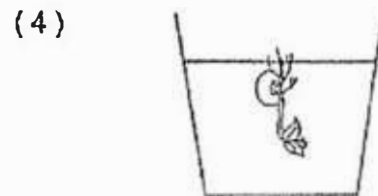
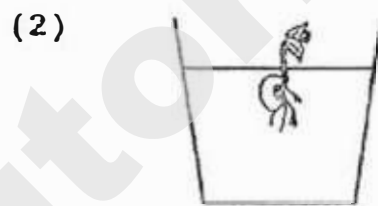
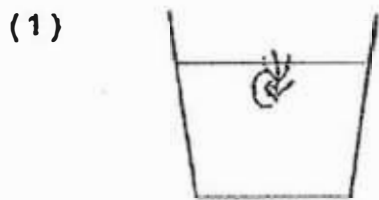

()

8. Study the life cycles of Animal P and Animal Q below.

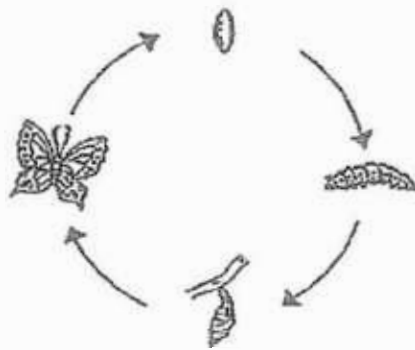

Animal P

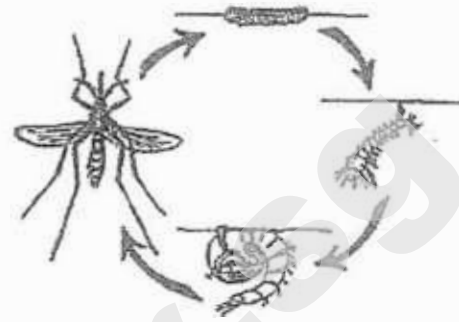

Animal Q

Which one of the following statements is true about the life cycles shown above?

- (1) Animal P lays eggs but Animal Q does not.
- (2) Both Animal P and Animal Q have a pupa stage.
- (3) The young of both Animal P and Animal Q live in land.
- (4) The young of both Animal P and Animal Q resemble their adults.

()

9. Study the flowchart below.

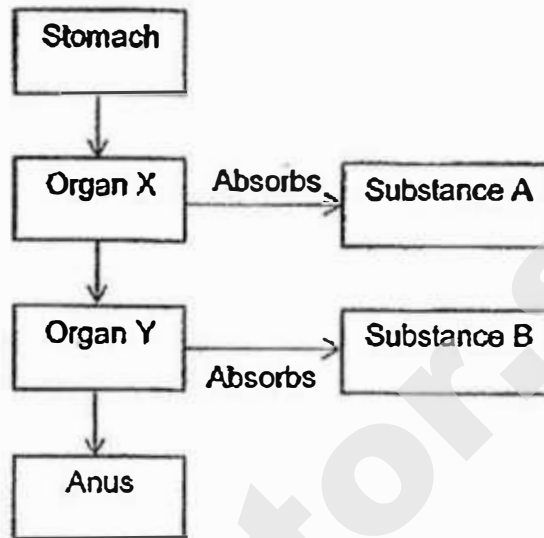

Which of the following correctly identifies the correct organs of the human body and the substances absorbed by it?

	Organ X	Organ Y	Substance A	Substance B
(1)	small intestine	large intestine	digested food	water
(2)	small intestine	large intestine	water	digested food
(3)	large intestine	small intestine	digested food	water
(4)	large intestine	small intestine	water	digested food

()

10. Ali wanted to test if the surface area of food affects the rate of digestion. He had four set-ups shown below.

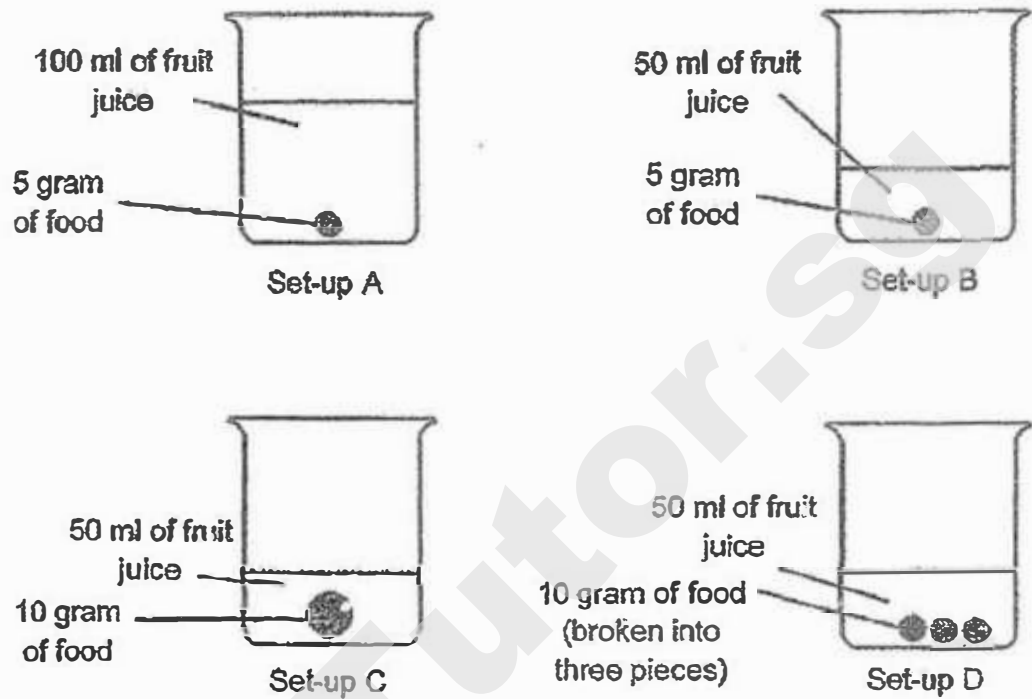

Which two set-ups should Ali use in order to ensure a fair test?

- (1) Set-ups A and C
- (2) Set-ups A and B
- (3) Set-ups C and D
- (4) Set-ups B and D

()

11. Which one of the following shows the exchange of gases in plants and animals correctly?

(1)

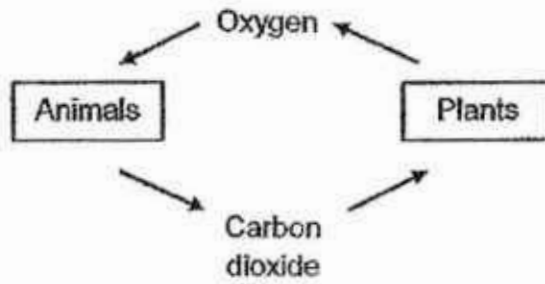

(2)

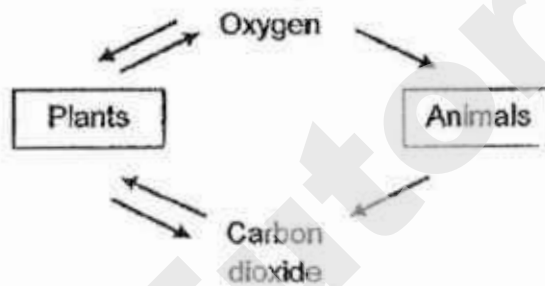

(3)

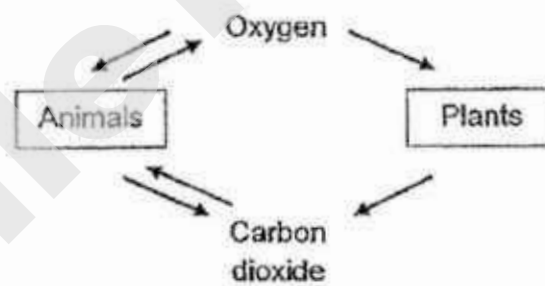

(4)

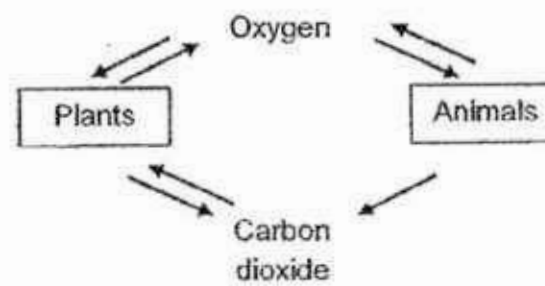

()

12. Air is pumped into the two containers through a number of tubes, as shown below.

Air flows from A to B and then to C.

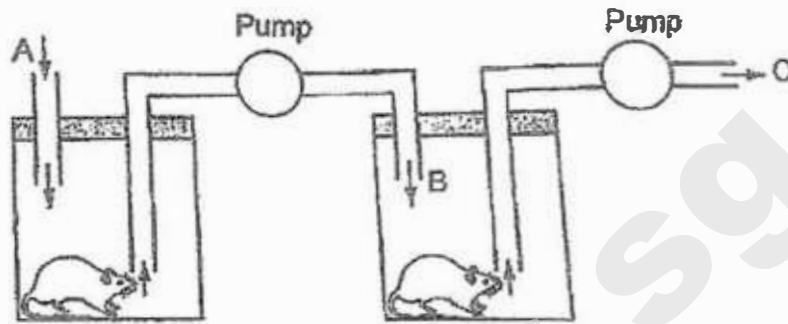

The bar below shows the composition of oxygen and carbon dioxide at A.



Which of the following bars correctly shows the composition of oxygen and carbon dioxide at C?

(1)



(2)

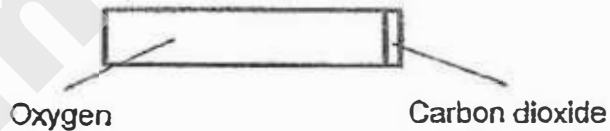

(3)

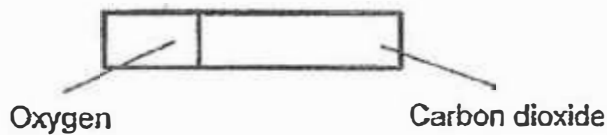

(4)

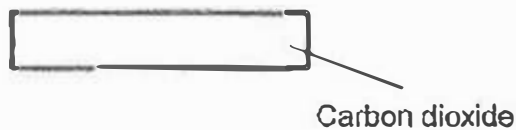

()

13. The diagram shows two flowers.

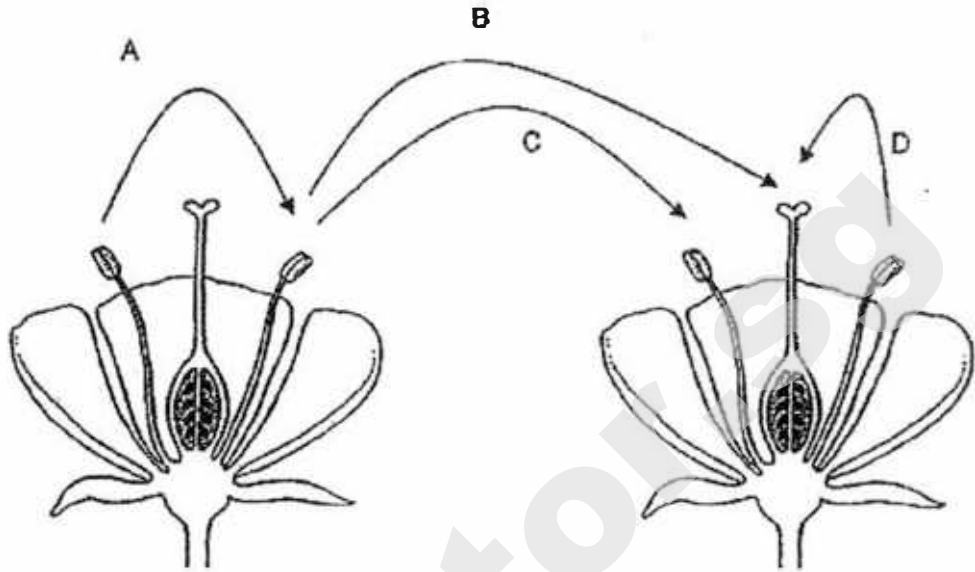

Which arrows show the process of pollination?

- (1) A and B
- (2) A and C
- (3) B and D
- (4) C and D

()

14. Study the flow chart below.

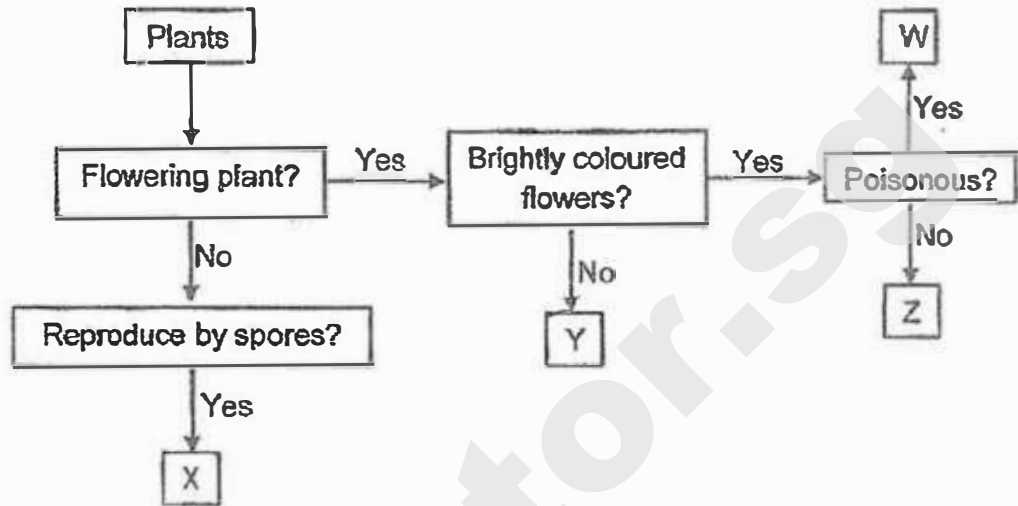

Which letters, W, X, Y or Z represent plants that are most likely pollinated by wind?

- (1) W
- (2) X
- (3) Y
- (4) Z

()

15. The diagram below shows a process that takes place in the human reproductive system.

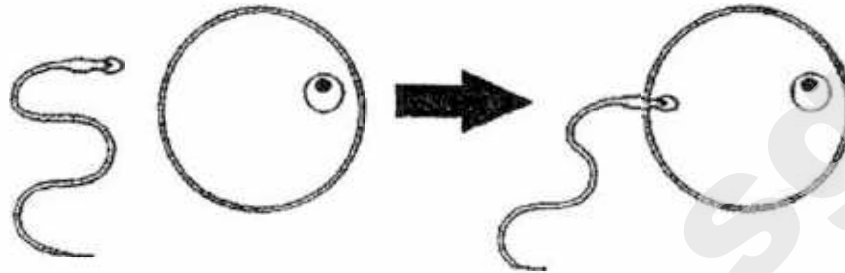



Which of the following statement(s) about the process is/are true?

- A. The fertilised egg develops in the stomach.
- B. The fertilisation process takes place in the female reproductive system only.
- C. A fertilised egg carries both characteristics inherited from the male and the female.
- D. The fertilisation process only takes place when more than one sperm is fused with the egg cell.

- (1) A only
- (2) B and C only
- (3) A and D only
- (4) B, C and D only

()

16. Bala measured the volume and mass of three balls which were made of different materials. His measurements were recorded below.

	Ball	Volume (ml)	Mass (g)
A		60	230
B		120	230
C		250	230

Based on his measurements, which one of the following conclusions is correct?

- (1) Objects of different sizes can have the same mass.
- (2) A smaller object occupies more space than a bigger object.
- (3) Objects of different sizes occupy the same amount of space.
- (4) An object that occupies more space is heavier than an object that occupies less space.

()

17. The diagram below shows a pair of gloves used to hold a tray in the hot oven.

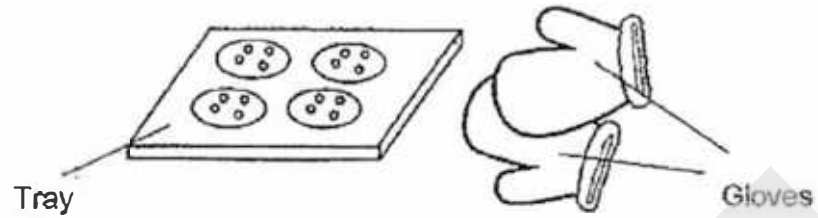

Study the properties of the four materials shown below.

Material	Properties of material	
	Can it conduct heat easily?	Is it flexible?
A	No	No
B	No	Yes
C	Yes	No
D	Yes	Yes

Which material is most suitable for making the pair of gloves?

- (1) A
- (2) B
- (3) C
- (4) D

()

18. The diagram below shows how four magnets are arranged such that they attract each other.

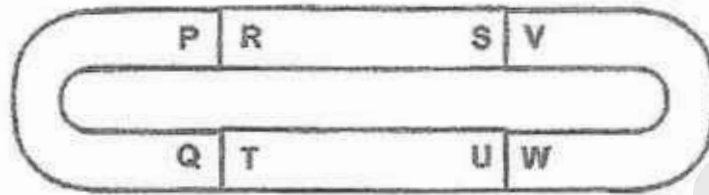

Which one of the following arrangements is not possible?

(1)

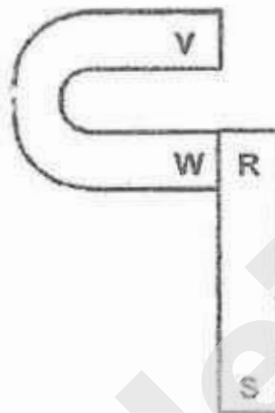

(2)

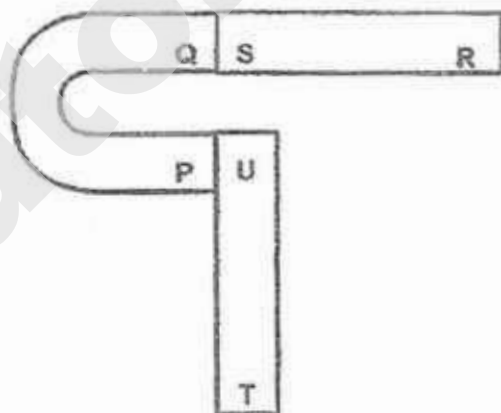

(3)

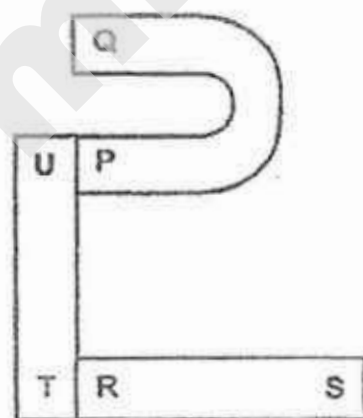

(4)

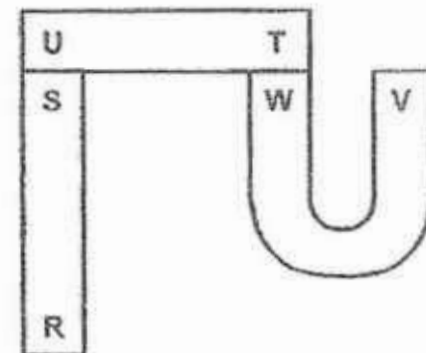

()

19. Which one of the following is a source of heat?

- (1) The moon
- (2) A bowl of chilli
- (3) A leather jacket
- (4) A lighted candle

()

20. Water vapour that rises to the sky is clean and pure. Why is it so?

- (1) Dirt evaporates from the water vapour.
- (2) Clean air helps to trap dirt in the water vapour.
- (3) The heat that causes water to evaporate also kills the bacteria in the water.
- (4) When water evaporates, water vapour becomes separated from the dirt.

()

21. The diagram below shows how blood is circulated in the body.

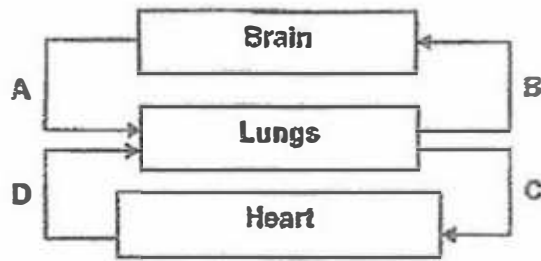

Which one of the paths shows the wrong direction of the flow of blood?

- (1) A and B only
- (2) B and C only
- (3) C and D only
- (4) A and C only

()

22. The diagram below shows a water tank which is used for flushing a toilet bowl. After flushing, water enters and refills the tank. Once the water level reaches height Z cm, the tank will stop refilling with water.

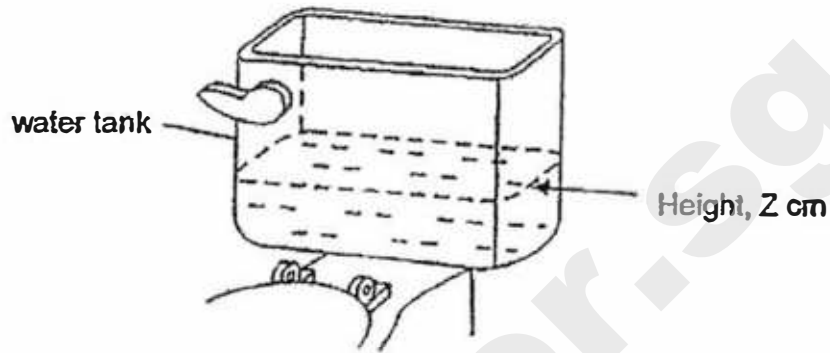

Salim suggested putting a brick into the water tank in order so that the water reaches height Z faster.

Which of the 3Rs of water conservation is Salim practising?

- (1) Reduce only
- (2) Reduce and Reuse
- (3) Reuse and Recycle
- (4) Recycle only

()

23. Gabriel filled a glass with water to the brim. When he put two ice cubes into the glass of water as shown in the diagram below, he observed that the water overflowed.

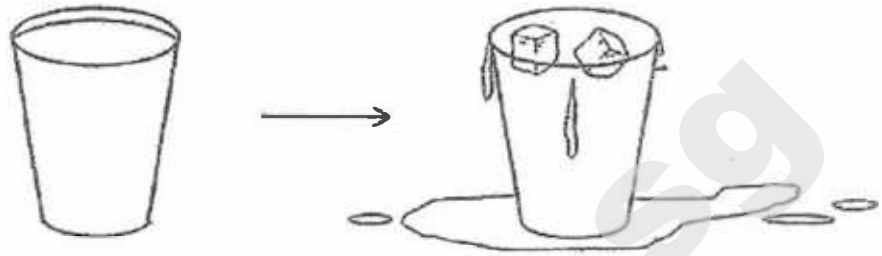

Which one of the following best explains Gabriel's observation?

- (1) Ice has mass.
- (2) Ice occupies space.
- (3) Ice has a definite shape.
- (4) Ice changes from one state to another.

()

24. In the diagram below, each child gave a statement about the reproduction of plants and animals.

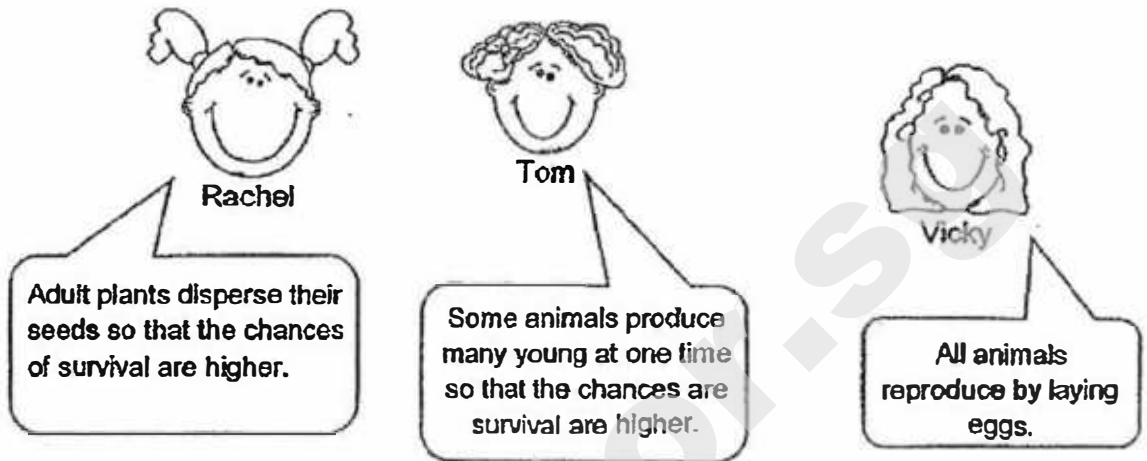

Who made correct statement(s)?

- (1) Rachel and Tom only
- (2) Rachel and Vicky only
- (3) Tom and Vicky only
- (4) Rachel, Tom and Vicky

()

25. Shawn was at a beverage stall buying a cup of hot tea. He noticed that the stall-holder would pour the tea from a container to another as shown in the diagram below.



When the tea flowed to another container, Shawn noticed 'mist' forming along the trail of the tea and guessed that the 'mist' is due to _____.

Which of the following is correct?

- (1) the evaporation of the tea
- (2) the condensation of the tea
- (3) the evaporation of the water
- (4) the condensation of the water vapour

()

26. Tom placed a ruler at the edge of the table and held it down firmly with his hand. On the other end of the ruler, he put an eraser and pressed the ruler down before taking his finger away.

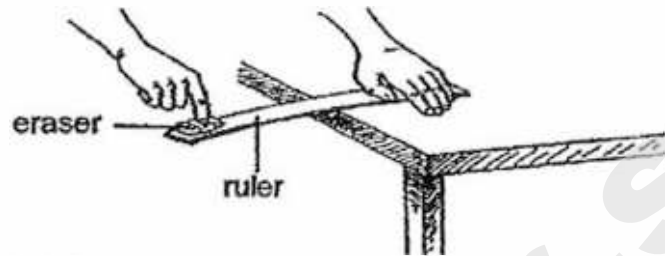

He noticed that the eraser was thrown off the ruler. From the results of the experiment, Tom was trying to find out if the ruler is _____.

- (1) strong
- (2) flexible
- (3) waterproof
- (4) transparent

()

27. The table below shows the freezing point of substances A, B, C and D.

Substance	Freezing point (°C)
A	0
B	5
C	35
D	50

Four students studied the above information and made the following statements.

Kelvin : Substance A is turning into a liquid at 0°C.

Yong Xi : Substances B and C are liquids at 30°C.

Joan : Substances C and D are solids at 20°C.

Aisha : Substance D is turning into a gas at 50°C.

Which of the following student is correct?

(1) Kelvin

(2) Yong Xi

(3) Joan

(4) Aisha

()

28. Melinda had two discs of magnets and one disc of plastic as shown below.

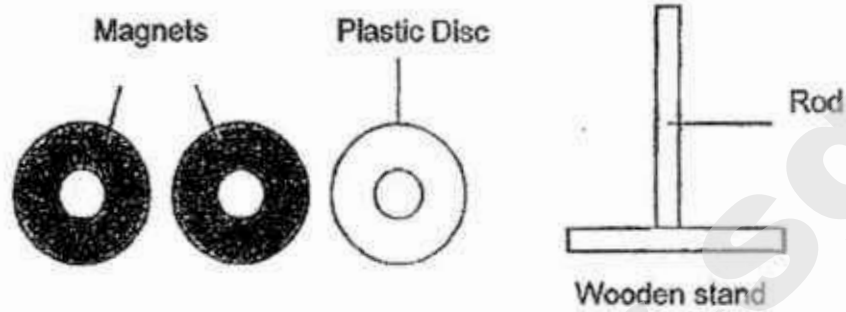

She placed all the three discs through the wooden rod in random order and recorded her observations below. Which of the following would not be observed by Melinda?

Diagram A	Diagram B
Diagram C	Diagram D

- (1) A and B only
- (2) A and D only
- (3) B and C only
- (4) B and D only

()

~End of Booklet A~

**SEMESTRAL ASSESSMENT 1 / 2017
PRIMARY 5**

**STANDARD SCIENCE
(BOOKLET B)**

Name : _____ ()

Date : 9 May 2017

Class : P5 _____

Total Time for Booklet A & Booklet B : 1 hour 45 min

INSTRUCTIONS TO CANDIDATES

1. Write your name, index number and class in the space above.
2. Do not turn over this page until you are told to do so.
3. Follow all instructions carefully.
4. Answer all questions.
5. For Section A, shade your answers for questions 1 to 28 in the Optical Answer Sheet (OAS) provided.
6. For Section B, write your answers for questions 29 to 40 in the space provided in the booklet.
7. The total marks for Booklet B is 44 marks.

Booklet A		/56
Booklet B		/44
Total		/100
Parent's Signature		

Section B (44 marks)

Write your answers to questions 29 to 40 in this booklet.

29. The diagram below shows the movement of blood in the human body. A, B, C and D represent the blood vessels.

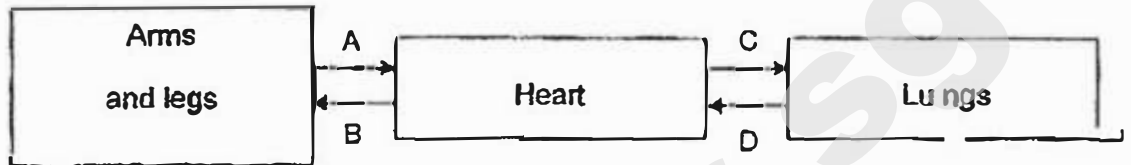

- (a) Which of the blood vessel(s), A, B, C or D, transport(s) blood rich in carbon dioxide? [1m]

- (b) Besides water, state two other useful substances that are transported by blood to the arms and legs of the human body. [2m]

- (c) What happens to the substances mentioned in (b) after they reach the arms and legs of the body? [1m]

	4
--	---

30. All made a model of the human respiratory system below.

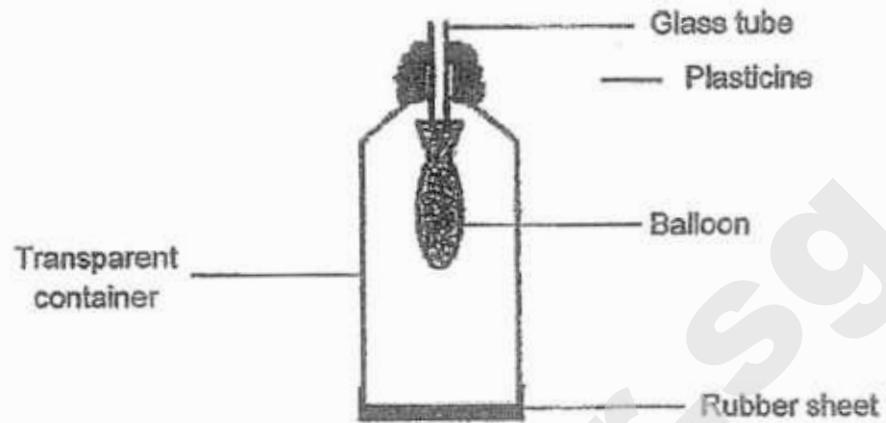

(a) Which organs of the human respiratory system represent the following parts of the model? [2m]

(i) Balloon : _____

(ii) Glass tube : _____

(b) What is the function of the organ in (a) (i)? [1m]

	3
--	---

31. The diagram below shows the human digestive system with the organs labelled.

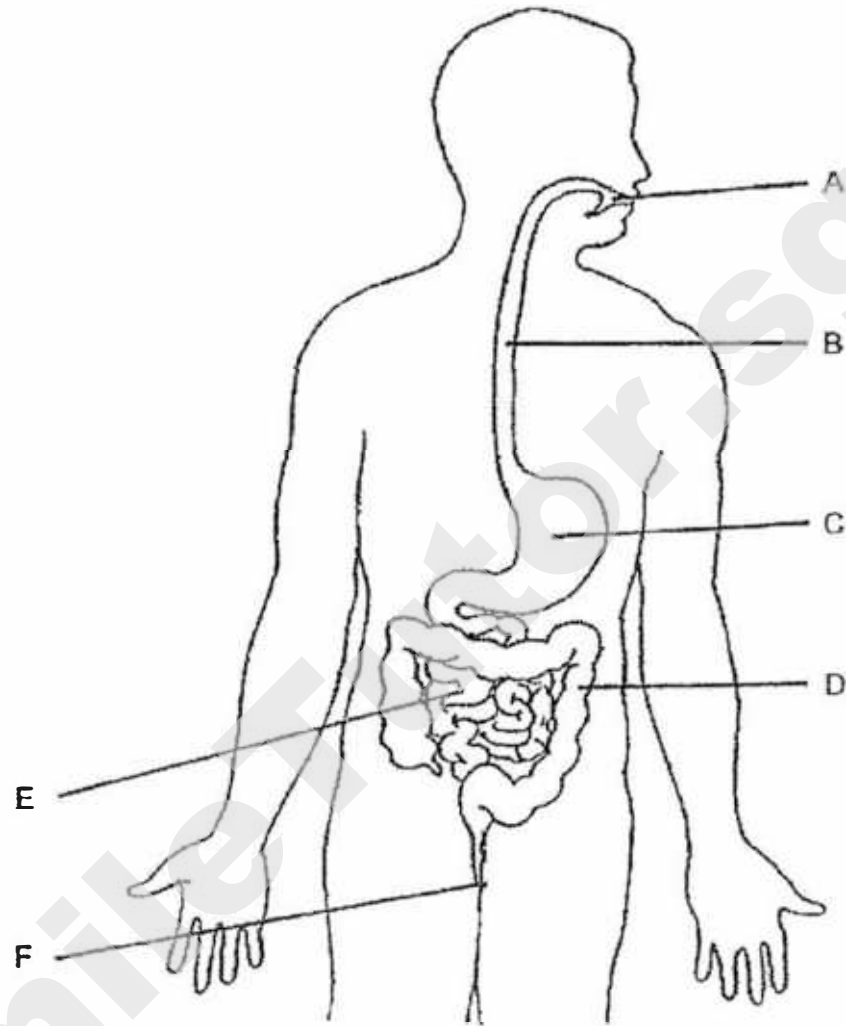

(a) State the organ(s) where

(i) digestion takes place: _____ [1m]

(ii) digestion ends: _____ [1m]

(b) State the function of organ F. [1m]

	3
--	---

Alice ate some food containing 100 grams of substance X, Y and Z each.

The table below shows the amount of undigested food at the start and at the end of the digestive system.

	Amount of undigested food left (grams)	
	Start	End
Substance X	100	30
Substance Y	100	100
Substance Z	100	50

- (c) Which of the three substances (X, Y or Z) could not be digested by Alice's digestive system? Explain your answer. [1m]

- (d) Give an example of food that cannot be digested. [1m]

	2
--	---

32. Ragu wanted to find out if the number of roots on a plant affects the amount of water absorbed by the plant. He prepared 3 identical containers A, B and C and filled them with equal amount of water. He placed a plant in both containers B and C. He also added a layer of oil on top as shown in the diagram below.

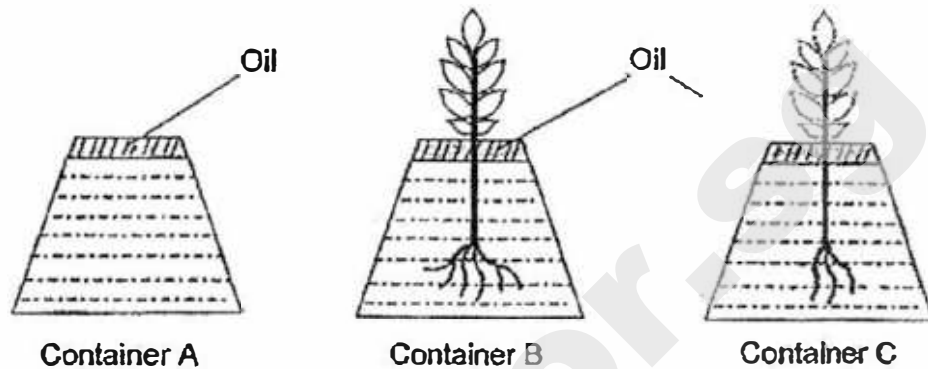

Ragu then measured the height of the water in the container for a few days. The results are shown in the graph below.

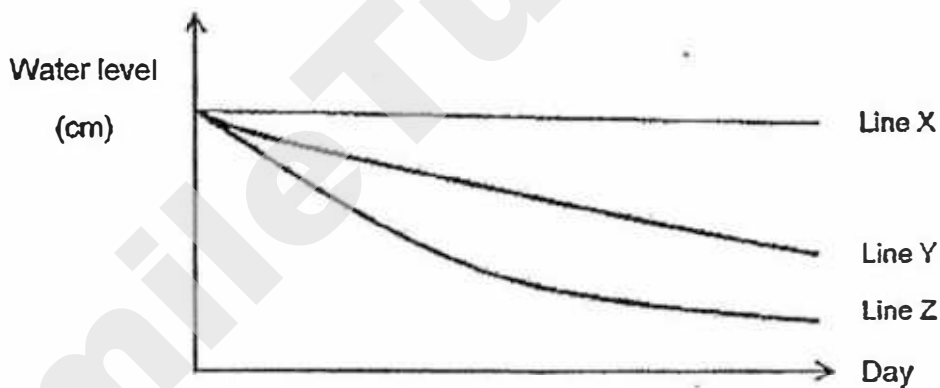

- (a) Which line, X, Y, or Z, represents the results collected for the plant in Container B? Explain your answer. [1m]

	1
--	---

- (b) Raju added a layer of oil into all the containers to ensure a fair test.
Explain why he added the oil. [1m]

- (c) Write down one variable that Raju had kept constant and one variable he had changed in order for the experiment to be a fair one. [1m]

To keep constant: _____

To change: _____

	2
--	---

33. Ali and his sister found a seed of Plant X shown below.



(a) What is the method of dispersal for the seed of Plant X? [1m]

(b) Give a reason for your answer in (a). [1m]

(c) Ali told her sister that if the seeds are not dispersed properly, overcrowding would happen and this is bad for the seedlings. Why is this so? [1m]

	3
--	---

They found another seed, a seed of Plant Y, and set up an experiment shown below.

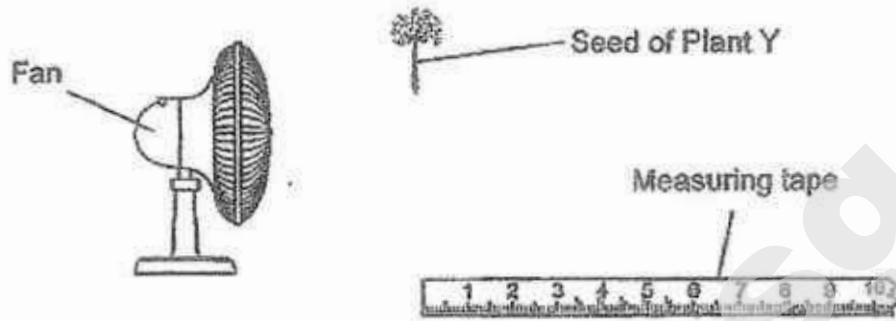

They wanted to investigate if the height where the seeds are dropped affects the distance that the seeds are dispersed. The result are shown in the table below.

Height (m)	Distance (m)
0.5	1
1	3
1.5	W
2	8

(d) What is the possible value of W? [1m]

(e) What can they conclude from the result of the experiment? [1m]

	2
--	---

34. Figure A and B below shows Mr Lim's swimming pool at different times.

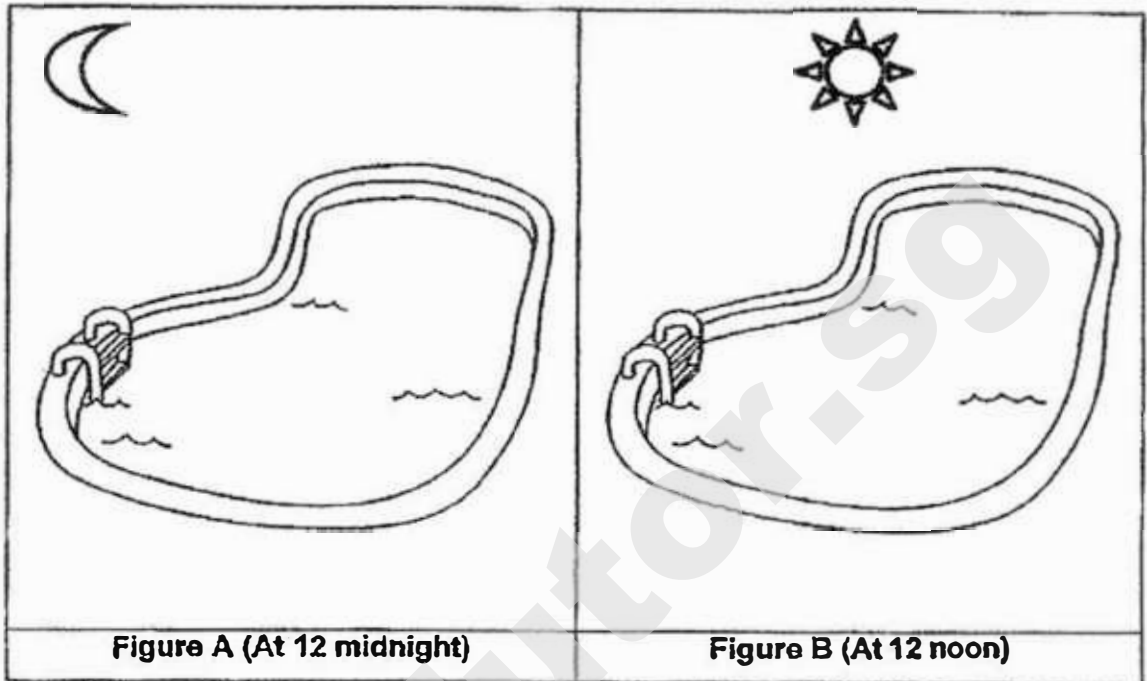

(a) The water in Figure _____ will evaporate faster. [1m]

(b) Explain your answer in (a). [1m]

(c) Mr Lim used a pool cover to reduce the amount of water in the pool from evaporating.

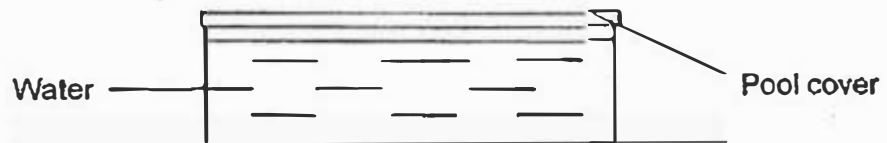

Provide two reasons how using a pool cover can reduce evaporation of water. [1m]

(i) _____

(ii) _____

	3
--	----------

35. Lily has two cups of water, X and Y, filled with ice. Cup X was left in the open on a table. She placed Cup Y in a bag and removed as much air as possible and sealed it before placing it on the table.

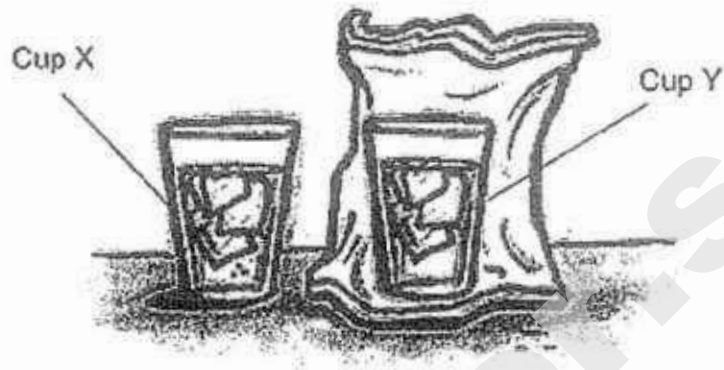

After a few minutes, water droplets formed on the outer surface of both cups.

- (a) Explain how these water droplets are formed on the surface of the cups. [2m]

After some time, she observed that less water droplets were found outside the surface of Cup Y than Cup X.

- (b) Explain the observation made by her. [1m]

- (c) Besides placing the cups in the same location, state another variable that must be kept the same in order to ensure a fair experiment. [1m]

	4
--	---

36. Siti has two beakers of water, A and B, at 30 °C. The beakers are made of the same material and of the same size. She then placed both beakers in the freezer.

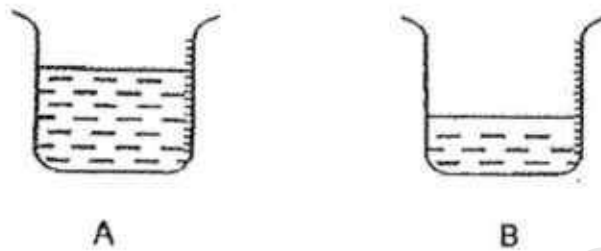

The graph below shows the changes in temperature of water in beakers A and B after some time.

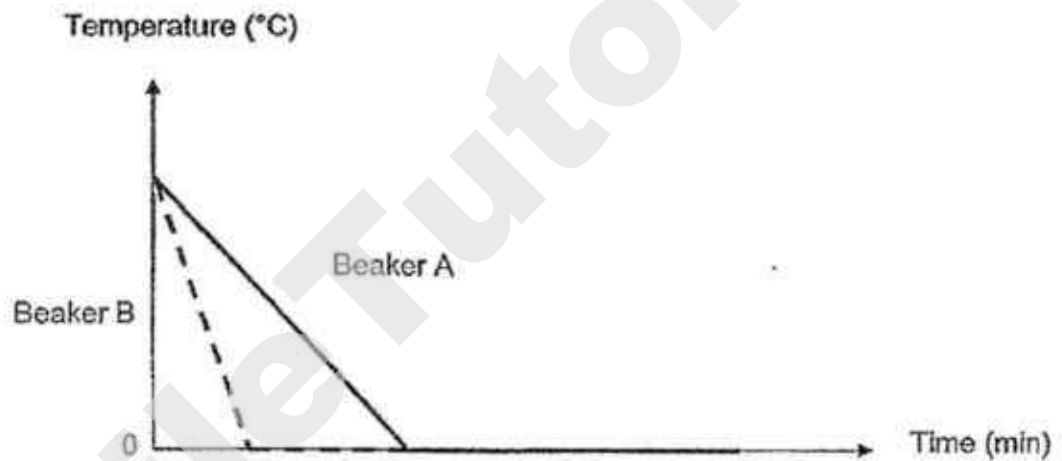

- (a) Which beaker (A or B) of water took a shorter time to reach its freezing point? [1m]

Beaker _____

- (b) Suggest a possible reason for the difference in time taken for each beaker of water to reach freezing point. [1m]

- (c) What is her aim of the experiment? [1m]

	3
--	---

- (d) Siti removed both cups from the freezer and left them on her kitchen table until all the ice melted.

Draw and label the graph of the changes in temperature of water for beaker A and B below. [2m]

Temperature ($^{\circ}\text{C}$)

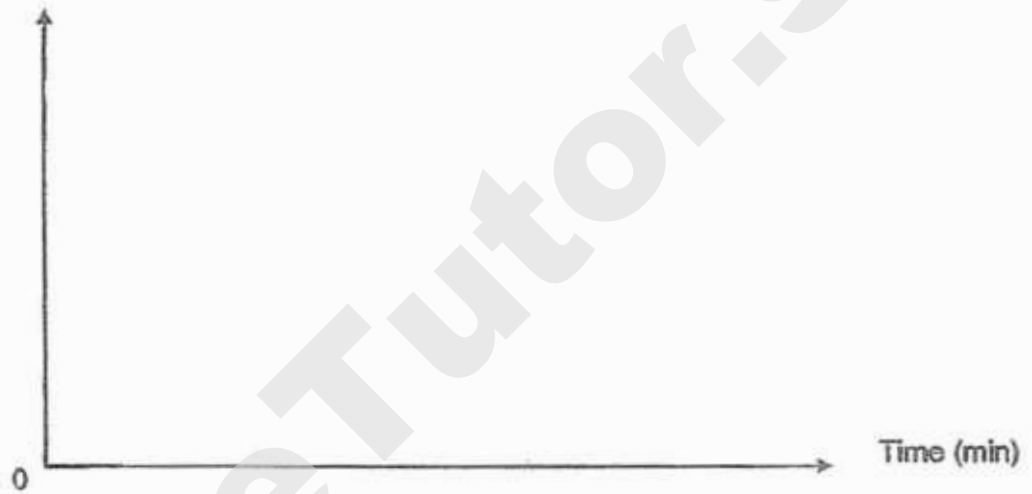

	2
--	---

37. Sally has a beaker with 65 ml of water. She placed a ball of plasticine into the water. She observed that the water level rose to 80 ml.

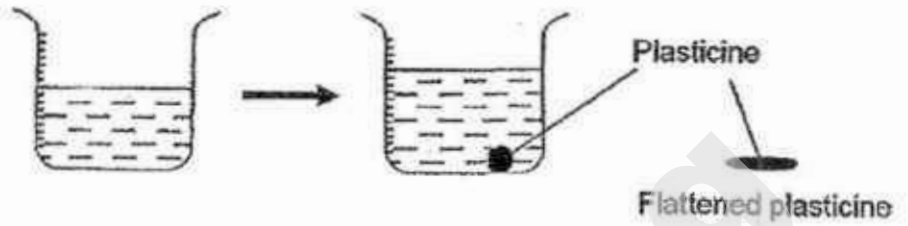

She then flattened the plasticine ball and placed it back into the water.

- (a) Where would the water level be this time? Explain your answer. [1m]

Sally then read a story, "The Crow and the Pitcher", where the crow dropped several stones into the pitcher so that it could drink the water.



- (b) Why did the water level increase when stones are dropped into the pitcher? [1m]

	2
--	---

- (c) Besides dropping the stones faster, suggest one thing that the crow could do to make the water level increase faster. [1m]

- (d) The crow found some styrofoam pieces and dropped them into the pitcher. However, the water level did not increase. Give a reason. [1m]

	2
--	---

SmileTutor.sg

38. Jen wanted to make the iron bar below into a magnet for her experiment.

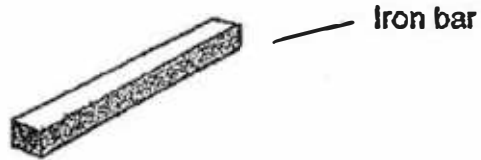

(a) Name one method she can use to make the iron bar into a magnet. [1m]

After making the iron bar into a magnet, Jen then placed it into a box of steel pins. She observed that the steel pins were attracted to the iron bar as shown below.

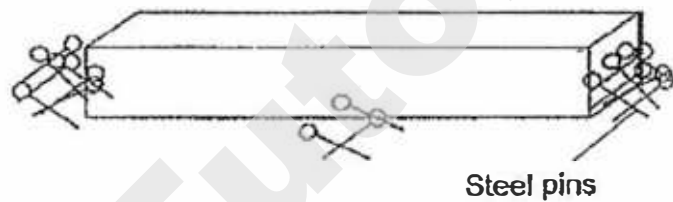

(b) Based on her observation, what could she conclude about the magnetic strength of the magnet? [1m]

(c) Jen repeated the experiment by placing the magnet into a box of copper clips. She observed that the magnet did not attract the copper clips. Why is this so? [1m]

(d) After Jen is done with her experiment, she no longer needs the magnet. Name two methods she can use to make the magnet lose its magnetic strength. [1m]

(i) _____ (ii) _____

	4
--	---

39. Mrs Chen taught her three children to conserve water by practising the 3 Rs. Her children wrote 'Reduce', 'Reuse' and 'Recycle' for each of the activities below.

Child	Activities	3 Rs
1	Using a mug when brushing your teeth.	Reduce
2	Using water from washing clothes to wash toilets.	Reuse
3	Using water from washing vegetables to water plants.	Recycle

- (a) Which child wrote the 3 Rs wrongly? [1m]

Child _____

- (b) Besides the activities mentioned above, describe two other activities where water can be reduced and recycled. [1m]

(i) Reduce: _____

(ii) Recycle: _____

	2
--	---

40. Jimmy used a thermometer to measure the temperature of warm water in a glass container.

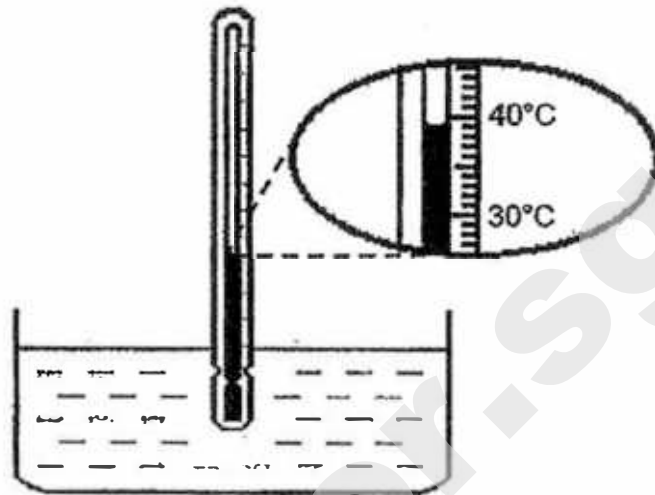

- (a) He measured the temperature after he had placed the thermometer into the warm water for ten minutes. Is the temperature correct? Explain your answer. [1m]

	1
--	---

Jimmy filled a tub with warm water at 60°C . He then immersed a cup of cold water at 5°C into the tub as shown in the diagram below.

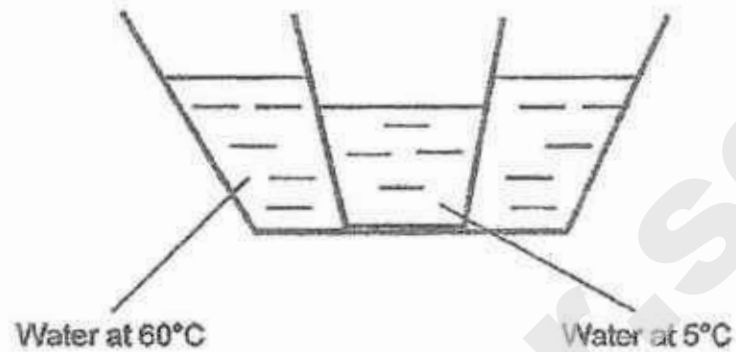

After some time, he measured the temperature of the water in both the tub and the cup. He discovered that both readings were the same.

- (b) Explain why the temperature of both the water in the tub and the cup became the same after some time. [1m]

	1
--	---

~End of Paper~

SCHOOL : RIVER VALLEY PRIMARY SCHOOL
LEVEL : PRIMARY 5
SUBJECT : SCIENCE
TERM : 2017 SA1

SECTION A

Q 1	Q2	Q3	Q4	Q5	Q6	Q7	Q8	Q9	Q10
3	3	1	2	4	4	2	2	1	3

Q 11	Q12	Q13	Q14	Q15	Q16	Q17	Q18	Q19	Q20
2	3	3	3	2	1	2	4	4	4

Q 21	Q22	Q23	Q24	Q25	Q26	Q27	Q28
1	1	2	1	4	2	3	2

SECTION B

Q29)	(a) Blood vessel A and C (b) Nutrients and oxygen (c) They will be converted to energy.
Q30)	(a) (i) lungs (ii) windpipes (b) For gaseous exchange
Q31)	(a) (i) A, C, E (ii) E (b) It is for the human waste materials to pass through. (c) Substance Y as Substance Y did not reduce its weight. (d) Seeds
Q32)	(a) Line Z. As the plant in Container B has more roots than container C, the rate of absorption of the plant in Container B is faster. (b) So that no water was lost due to evaporation

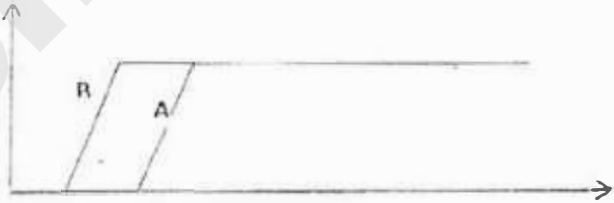
	<p>(c) To keep constant: The amount of water To change: The number of root on each plant</p>
Q33)	<p>(a) By wind (b) It has a wing-like structure for the seed to be blown away further. (c) The seedlings would have to fight for food, water and sunlight which resulted in some seedlings withering and dying. (d) 6 meters (e) The higher the seeds were released, the further they would land.</p>
Q34)	<p>(a) B (b) The heat energy from the sun evaporated the water from the swimming pool. (c) The pool cover reduces the temperature of the water. Even though with the cover is there, water still evaporate. The water vapour will come in contact with the cool surface of the pool cover, loses heat and forms water droplets which drip back into the pool.</p>
Q35)	<p>(a) Warm water vapour touches the cooler surface of the cups, loses heat and condense and forming water droplets (b) There is lesser water vapour around Y. So lesser water vapour touches the cooler Cup Y and condenses to form water droplets. (c) The amount of water in both cups.</p>
Q36)	<p>(a) B (b) Lesser water lose heat faster. (c) Different volume of water affects the time taken for it to freeze. (d)</p> 
Q37)	<p>(a) It would still be at 80 ml. Plasticine is a solid which has a definite volume. (b) As the stones are solid which has a definite volume, they occupy space. (c) Use larger stones (d) The styrofoam is light and will float, it did not occupy the space of the water. So, the water level did not increase.</p>

Q38)	<p>(a) Stroke the bar with a magnet with one pole in one direction for at least 20 times.</p> <p>(b) A magnet is stronger at its poles.</p> <p>(c) As copper is not a magnetic material, it cannot be attracted to a magnet.</p> <p>(d) (i) Drop the magnet from the highest point (ii) Heat up the magnet</p>
Q39)	<p>(a) Child 3</p> <p>(b) (i) Reduce : Use the water for watering plant after washing rice (ii) Recycle : Filter the dirty water into drinkable water</p>
Q40)	<p>(a) No. The water loses heat to the surrounding./ The water has cooled down.</p> <p>(b) The tub of water lost heat to the cup of cold water and the cup of cold water gained heat from the tub of warm water.</p>

FIRST SEMESTRAL ASSESSMENT 2017

NAME: _____ ()

DATE: 3 May 2017

CLASS: PRIMARY 5 SY / C / G / SE / P

Parent's Signature:

SCIENCE

BOOKLET A

28 questions

56 marks

Total time for Booklets A & B: 1 h 45 min

DO NOT OPEN THIS BOOKLET UNTIL YOU ARE TOLD TO DO SO.

FOLLOW ALL INSTRUCTIONS CAREFULLY.

A - 1 of 20

Part I (56 marks)

For each question from 1 to 28, 4 options are given.

One of them is the correct answer. Make your choice, (1, 2, 3 or 4).

Shade the correct oval (1, 2, 3 or 4) on the Optical Answer Sheet.

1. Jason drew samples of partially digested food in different parts of a digestive system as shown below.

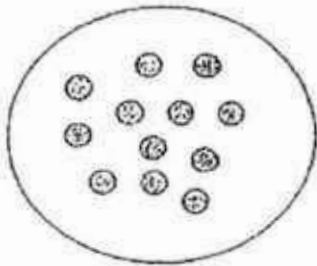

Food Sample
X

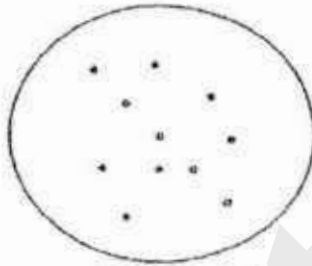

Food Sample
Y

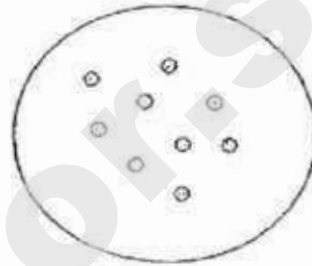

Food Sample
Z

If Food Sample Z is taken from the stomach, which part of the digestive system are Food Samples X and Y taken from respectively?

	Food Sample X	Food Sample Y
(1)	Mouth	Gullet
(2)	Gullet	Small intestine
(3)	Small intestine	Mouth
(4)	Large intestine	Gullet

2. Janice wrote her observations about organisms P and S as shown below.

<u>Organism P</u>
<ul style="list-style-type: none"> • It needs sunlight. • It cannot move by itself. • It has flowers.

<u>Organism S</u>
<ul style="list-style-type: none"> • It reproduces by laying eggs. • it feeds its young with milk. • It can die.

What are organisms P and S most likely to be?

	<u>Organism P</u>	<u>Organism S</u>
(1)	Rose plant	Python
(2)	Bird's nest fern	Platypus
(3)	Bird's nest fern	Python
(4)	Rose plant	Platypus

3. Ian managed to put only 9 objects into a box. He could not squeeze in 1 more Object X into the box as shown below.

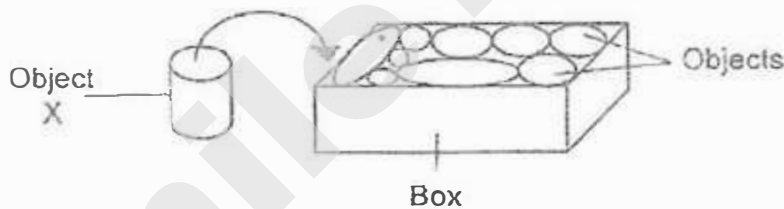

What property of matter does this activity show about Object X?

- (1) It has mass.
- (2) It has a fixed volume.
- (3) It can be compressed.
- (4) It does not have a definite shape.

4. Alexis set up an experiment as shown below.

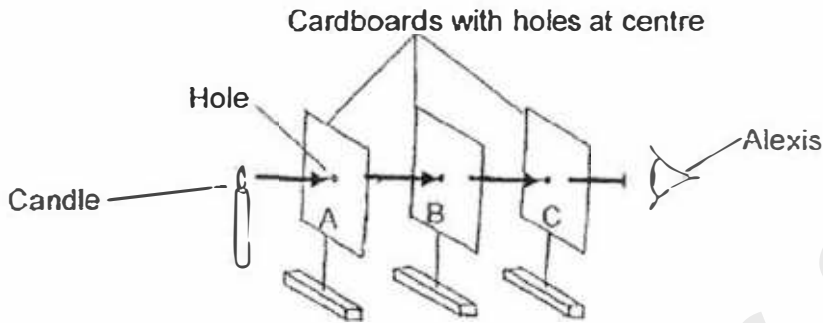

She was able to see the candle when she placed the cardboards with the holes in a straight line.

Which one of the following action(s) can Alexis do in order to find out if light only travels in a straight line?

- (1) Remove the candle.
- (2) Shift cardboard B to the left.
- (3) Replace the candle with a pencil.
- (4) Replace the cardboards with clear glass.

5. Sue used a saucepan as shown below.

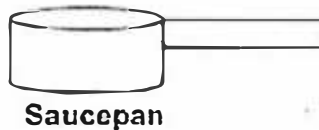

Saucepan

Which one of the following is not a possible shadow formed by the above saucepan?



(1)



(3)



(2)



(4)

6. Zena has 2 similar Cups, A and B. Each cup contains a different amount of water and has a different temperature as shown below.

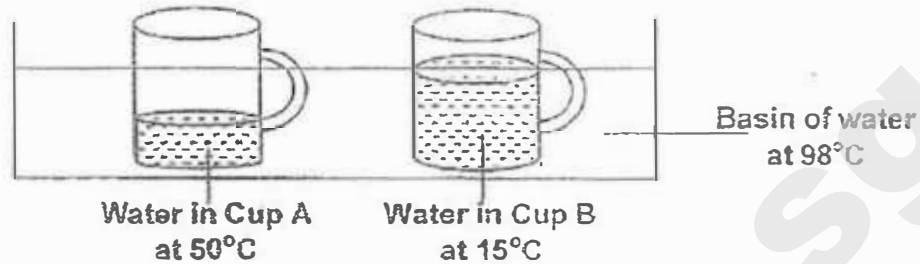

She puts both cups of water in a basin of 98°C water. She concluded based on her experiment that a longer time is needed to heat up a greater volume of water.

Why can't Zena make that conclusion based on her experiment?

- (1) Only the volume of water in both cups was not the same.
 - (2) The temperature of water in the basin was kept at 98°C.
 - (3) Cup A has less water but a lower temperature than Cup B.
 - (4) Cup B has more water but a lower temperature than Cup A.
7. Ciera studied the life cycle of Animal X and recorded its life cycle in the bar graph below.

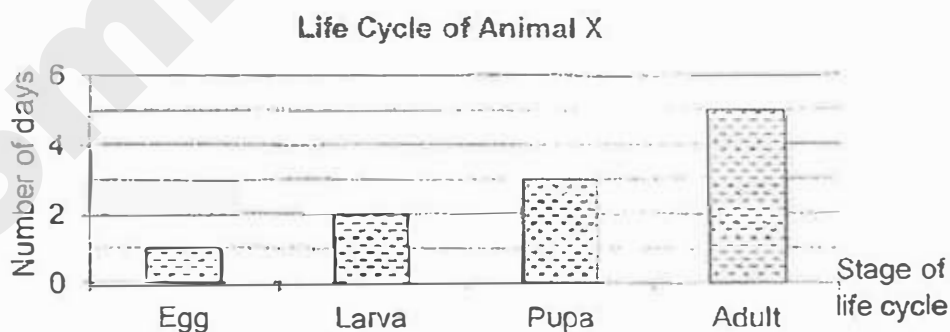

Based on the information provided in the above bar graph only, which one of the following statements about Animal X is correct?

- (1) Animal X took 5 days to lay eggs.
- (2) The pupa is bigger than the larva.
- (3) The larva and the pupa live in water.
- (4) The pupa took 3 days to become an adult.

8. Study Jamie's family tree below.

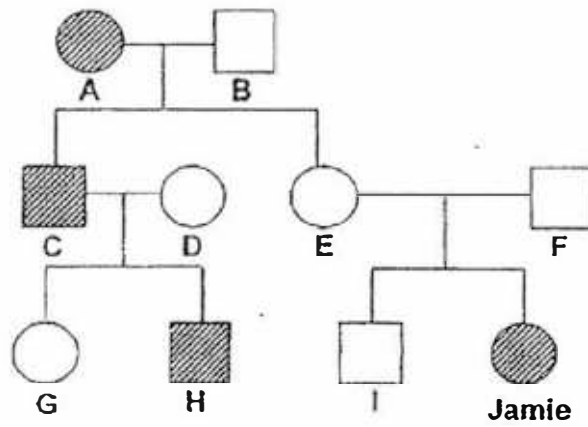

Legend

- Female
- Female with characteristic X
- Male
- Male with characteristic X

Based on the family tree above, who did Jamie inherit characteristic X from?

- (1) A
- (2) B
- (3) C
- (4) H

9. Felicia conducted an experiment using pieces of Bread, A, B, C and D. The bread had different amounts of water and were placed in different temperatures as shown in Tables 1 and 2 below.

Bread	Temperature of surrounding air		
	0°C	7°C	32°C
A	√		
B		√	
C			√
D			√

Table 1

Bread	Amount of water added to each piece of bread		
	0 ml	3 ml	5 ml
A	√		
B		√	
C			√
D		√	

Table 2

On which bread, A, B, C or D, would Felicia observe the least amount of bread mould growth?

- (1) A
- (2) B
- (3) C
- (4) D

10. Raine set-up an experiment to separate Substances L and M as shown below. Both substances L and M are heated in a flask. After some time, only Substance L remained in the flask.

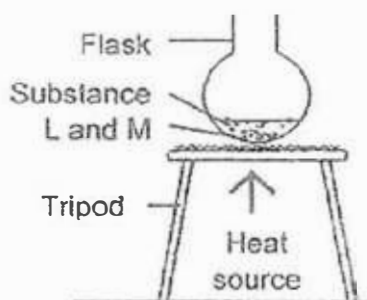

If the temperature of heat source is constantly at 116°C , which one of the following could most likely represent the boiling points of Substances L and M?

	Boiling point of Substance L	Boiling point of Substance M
(1)	86°C	156°C
(2)	100°C	100°C
(3)	86°C	116°C
(4)	156°C	86°C

11. The diagram below shows the water cycle that takes place in a reservoir. Processes A and B are important processes of the water cycle.

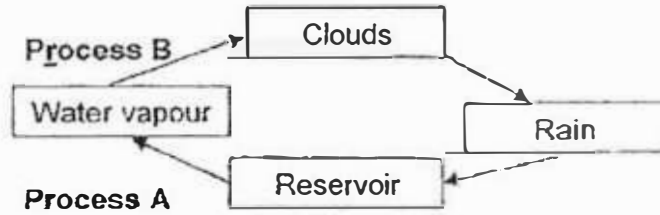

The Water Cycle

Which one of the following correctly represents Processes A and B?

	Process A	Process B
(1)	Melting	Condensation
(2)	Condensation	Condensation
(3)	Condensation	Evaporation
(4)	Evaporation	Condensation

12. Della recorded her observations of 3 objects, A, B and C, as shown below.

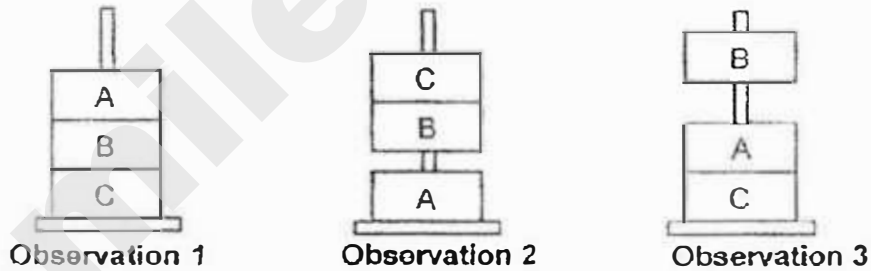

Which one of the following statements about Objects A, B and C is true?

- (1) Object A is definitely not a magnet.
- (2) Object C is definitely not a magnet.
- (3) Object A and B are definitely magnets.
- (4) Objects B and C are definitely magnets.

15. The diagram shows a capped bottle with its end open in a trough of water.

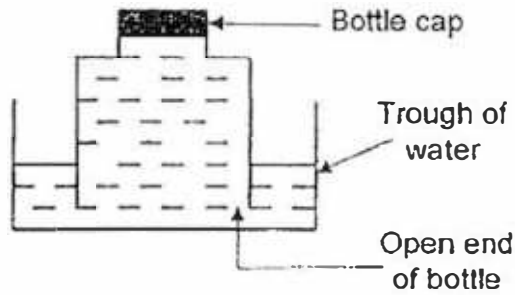

Which one of the following diagrams correctly shows what would happen to the water level in the bottle when the cap of the bottle is removed?

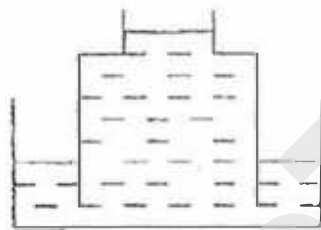

(1)

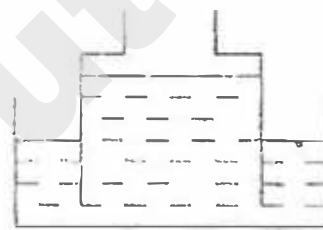

(3)

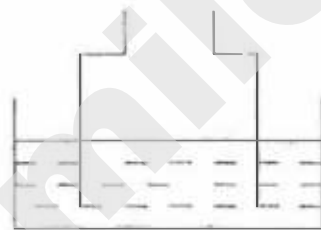

(2)



(4)

16. Study the life cycles of Animals X and Y as shown below.

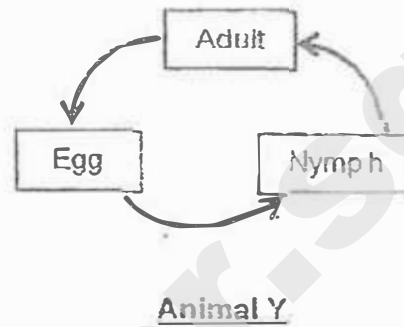
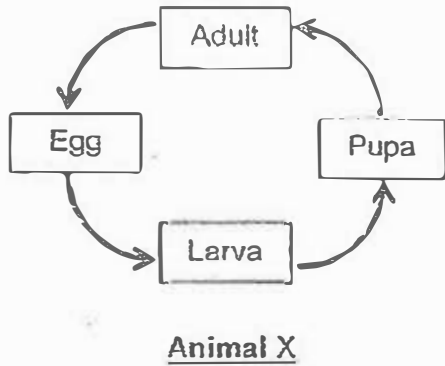

Which statement about the life cycles of Animals X and Y is definitely correct?

- (1) Animal X has a longer life span than Animal Y.
- (2) Animal Y does not moult at the nymph stage.
- (3) The young of Animal X does not look like the adult.
- (4) The adult of Animal X lays eggs in water but the adult of Animal Y lays eggs on land.

17. Which one of the following graphs shows Sean's heartbeat rate slowed down after he stopped jogging?

(1) Heartbeat rate

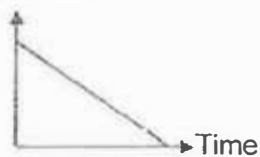

(3) Heartbeat rate

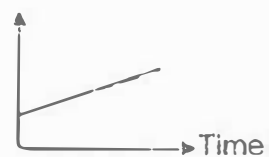

(2) Heartbeat rate



(4) Heartbeat rate



18, Sally has 8 marbles as shown below.

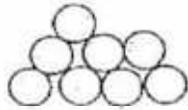

Which one of the following should Sally choose if she wants to find out how heavy each ball is?

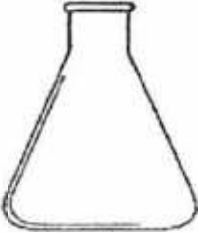
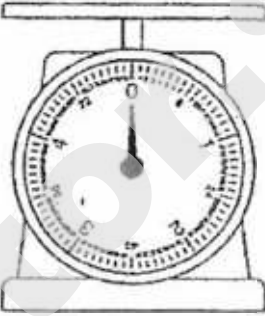
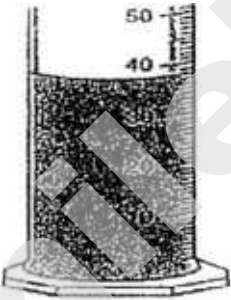
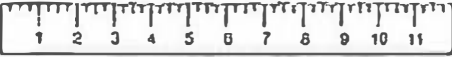
 <p>(A) Conical flask</p>	 <p>(C) Weighing scale</p>
 <p>(B) Measuring cylinder</p>	 <p>(D) Ruler</p>

(1) B only

(2) C only

(3) A and B only

(4) A, B, C and D

19. Cecilia recorded the number of paper clips that electromagnets, A, B and C could attract in the table below.

Electromagnet	Number of paper clips attracted
A	9
B	12
C	4

Based on the above results, which of the following set-ups correctly represents electromagnets, A, B and C?

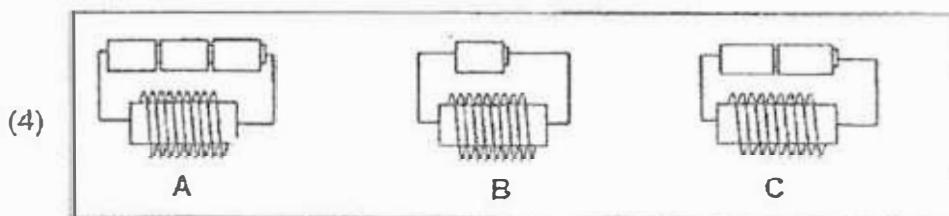
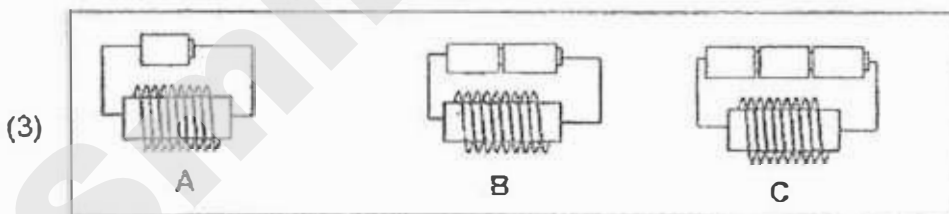
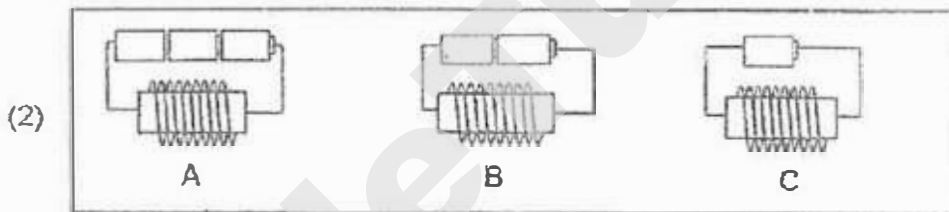
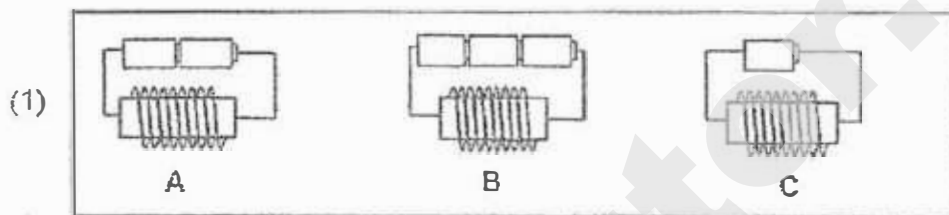

20. Which of the following activities shows the slowing down of heat gain by the ice?

A)



covering ice block
with wood shavings

C)

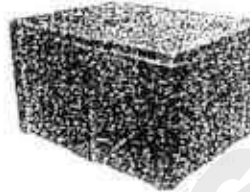

putting ice cubes into
styrofoam box

B)



putting ice into
hot coffee

D)



putting ice cubes
on a metal tray

(1) A and C only

(3) A, C and D only

(2) B and D only

(4) A, B, C and D

21. Study the diagram below.

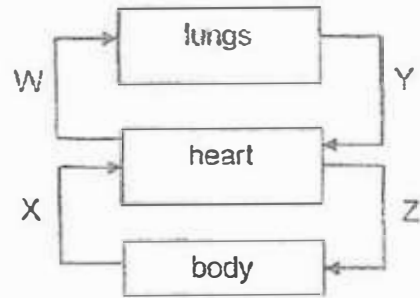

Which blood vessels, W, X, Y and Z, has been described wrongly?

	Blood Vessels	Type of Blood
1)	W	Rich in carbon dioxide
2)	X	Rich in carbon dioxide
3)	Y	Rich in oxygen
4)	Z	Rich in carbon dioxide

22. Leonard placed 2 containers of the green bean seeds, A and B under a lamp. He put different number of seeds in each container and recorded the average height and width of the seedling after 10 days. Equal amounts of water were provided for the seeds each day.

Container	Number of seeds	Average height of seedlings	Average width of seedlings
A	20	10 cm	1mm
B	5	6.5cm	3mm

Which one of the following most likely explains why the seedlings in container A grew taller than the seedlings in container B?

- (1) Seedlings in container A needed to compete for more air.
 - (2) Seedlings in container A needed to compete for more sunlight.
 - (3) Seedlings in container A received more nutrients since they are taller.
 - (4) Seedlings in container A had more food stored in their seed leaves.
23. The table below shows the freezing points and boiling points of 3 different substances, R, S, and T.

Substance	Freezing Point (°C)	Boiling Point (°C)
R	40	180
S	20	120
T	0	80

Which of the Substances, R, S and/or T is/are liquid(s) at 100°C?

- (1) R only
- (2) R and S only
- (3) T only
- (4) None of the above

24. Lisa poured equal amounts of water into 2 test tubes as shown below. She placed a similar plant each into Test tubes X and Y. Only the roots of the plant in Test tube X were coated with wax.

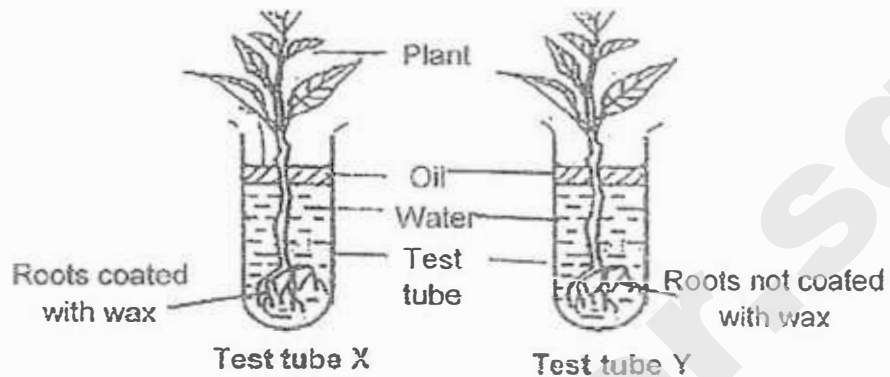

She recorded the amount of water left in each test tube after 5 days in the table below. Which set of data would she expect to see at the end of the experiment?

(1)

Beaker	Volume of water at the start (ml)	Volume of water left after 5 days (ml)
X	500	500
Y	500	480

(2)

Beaker	Volume of water at the start (ml)	Volume of water left after 5 days (ml)
X	500	540
Y	500	520

(3)

Beaker	Volume of water at the start (ml)	Volume of water left after 5 days (ml)
X	500	460
Y	500	480

(4)

Beaker	Volume of water at the start (ml)	Volume of water left after 5 days (ml)
X	500	480
Y	500	500

25. A table below shows the length of different parts of a seed over a period of 8 days.

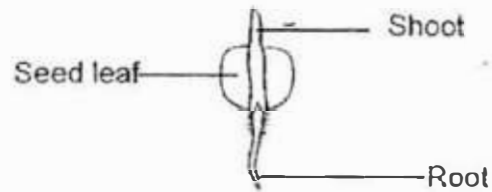

Day	Length (cm)	
	Part X	Part Y
1	0	0
2	0	0
3	0	0
4	0.1	0
5	0.5	0
6	1	0.1
7	1.4	0.3
8	1.9	0.8

Based on the above table, which parts of the seed do Parts X and Y represent?

	Part X	Part Y
(1)	Seed leaf	Root
(2)	Shoot	Root
(3)	Seed leaf	Shoot
(4)	Root	Shoot

26. The diagrams below show the plant and human reproductive systems.

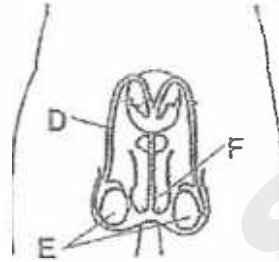
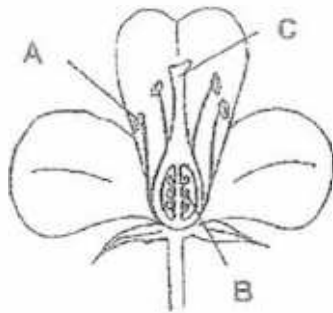

In which parts, A, B, C, D, E and F, are the male reproductive cells produced?

- | | |
|------------------|---------------------|
| (1) A only | (3) C and F only |
| (2) A and E only | (4) A, C and F only |

27. The diagram below shows a human reproductive system.

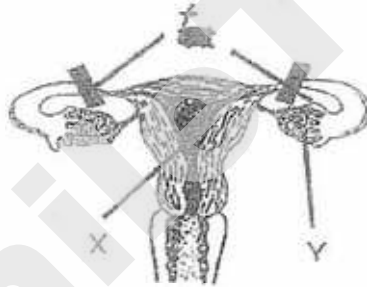

Explain how blocking parts W prevent reproduction from taking place.

- (1) The eggs in parts Y will die.
- (2) The sperms in parts W will die.
- (3) The eggs cannot move to part X.
- (4) The sperms cannot move to part W.

28. A group of workers installed the steel cable from Point A to Point B during a 28°C day as shown in the diagram below.

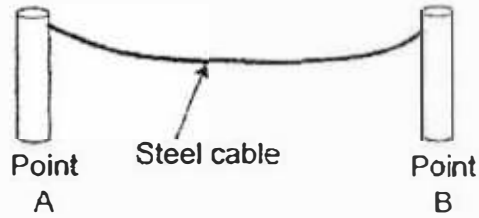

Which one of the following correctly shows how the cables would appear on days when their temperatures are 5°C day and 38°C day respectively?

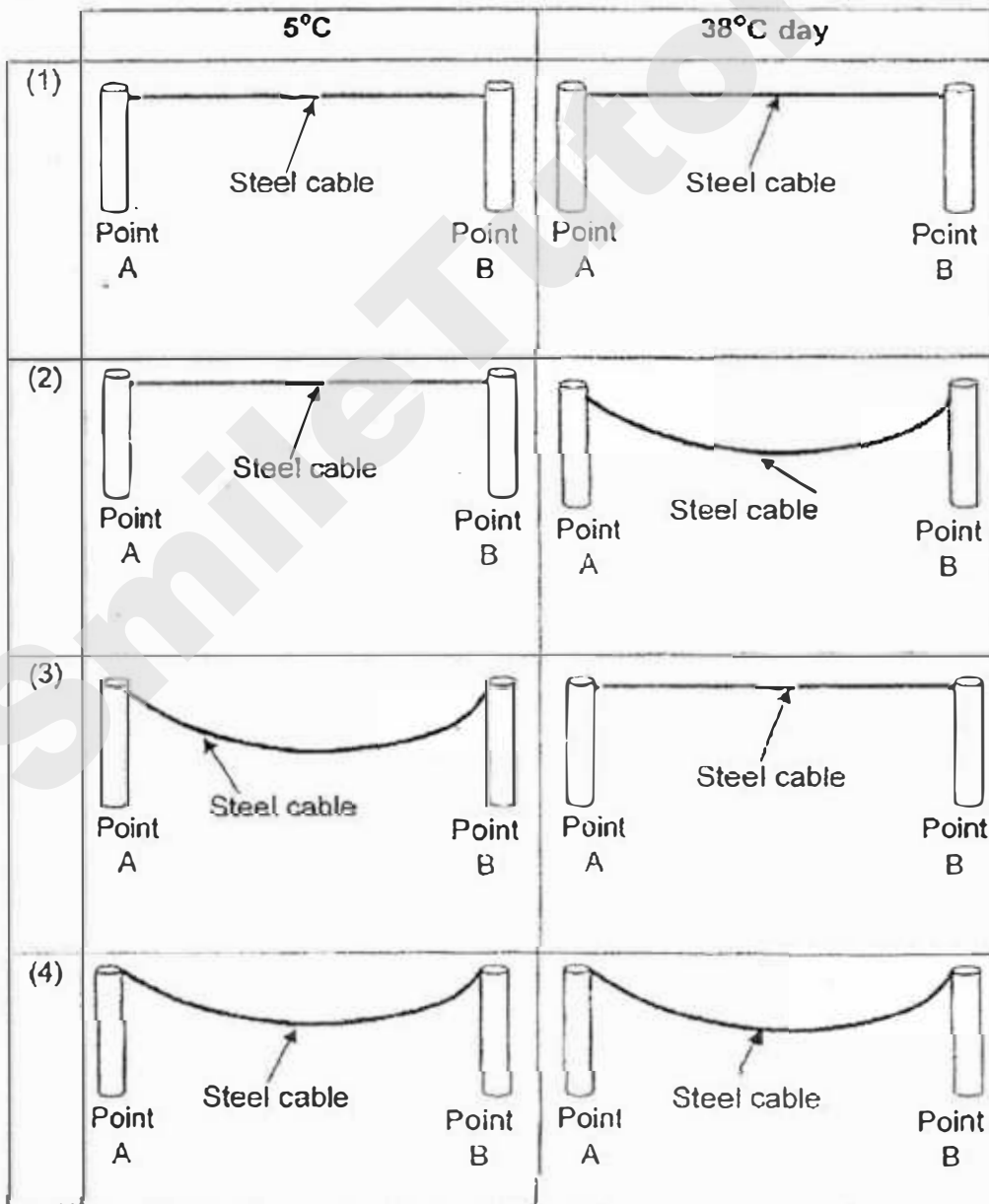

FIRST SEMESTRAL ASSESSMENT 2017

NAME: _____ ()

DATE: 3 May 2017

CLASS: PRIMARY 5 SY / C / G / SE / P

Parent's Signature:

SCIENCE
BOOKLET B

	Total Actual Marks	Total Possible Marks
Booklet A		56
Booklet B		44
Total		100

12 questions

44 marks

Total time for Booklets A & B: 1 h 45 min

DO NOT OPEN THIS BOOKLET UNTIL YOU ARE TOLD TO DO SO.

FOLLOW ALL INSTRUCTIONS CAREFULLY.

Part II (44 marks)

Answer all the following questions.

29. Alan placed a large ice block at 0°C in a 20°C enclosed room. After some time, he observed that there was "white cloud" forming around the ice block.

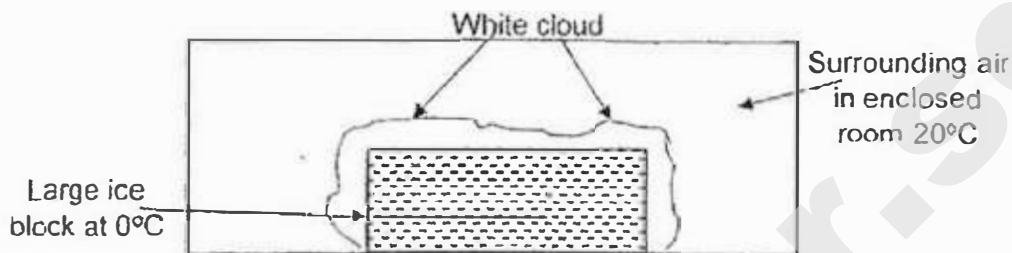

- a) What was the "white cloud" made up of? (1m)

- b) **Circle** the correct word in each box below. (2m)

The vapour from the surrounding air heat
and onto the air around the
ice block.

- c) **Without adding or changing the large ice block**, explain how Alan can increase the amount of "white cloud" forming around the large ice block. (1m)



30. a) Study the flowchart below.

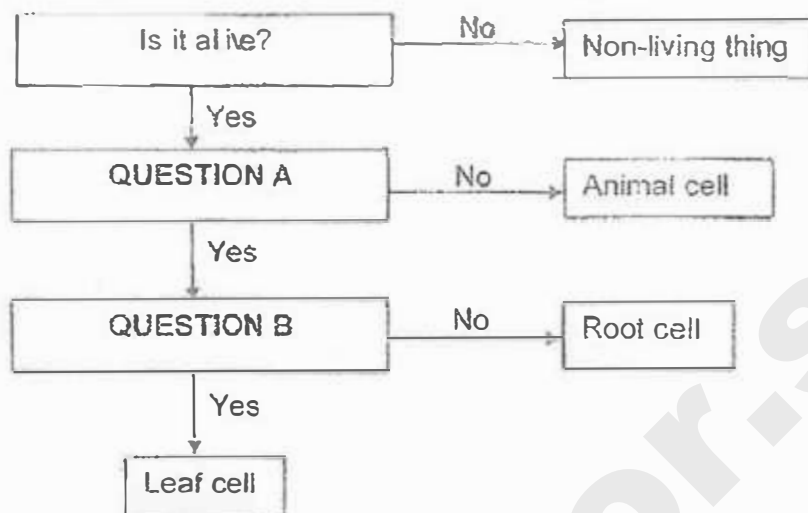

Based on the above flowchart, complete the 2 questions below to classify the different cells in the chart. (2m)

Question A	Does it have _____?
Question B	Does it have _____?

b) A bag of Solution X is placed in a basin of Solution Y. Owen observed that Solution X could not exit the special plastic bag but Solution Y could enter the special plastic bag.

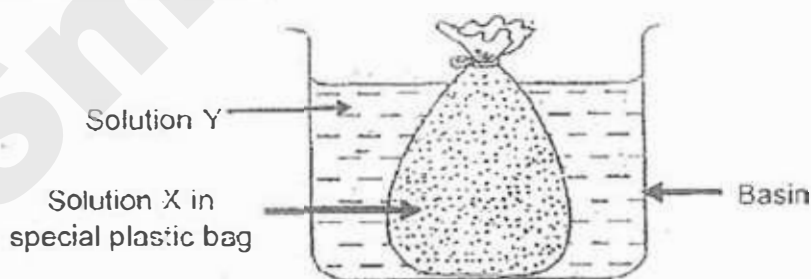

i) Based on his setup above, which part of a plant cell has a similar function as the special plastic bag? (1m)

ii) What happened to the size of the bag at the end of the experiment? (1m)

31. a) Pie Chart A shows the average composition of air John breathed in before an exercise. Pie Chart B shows the average composition of air John breathed out during an exercise.

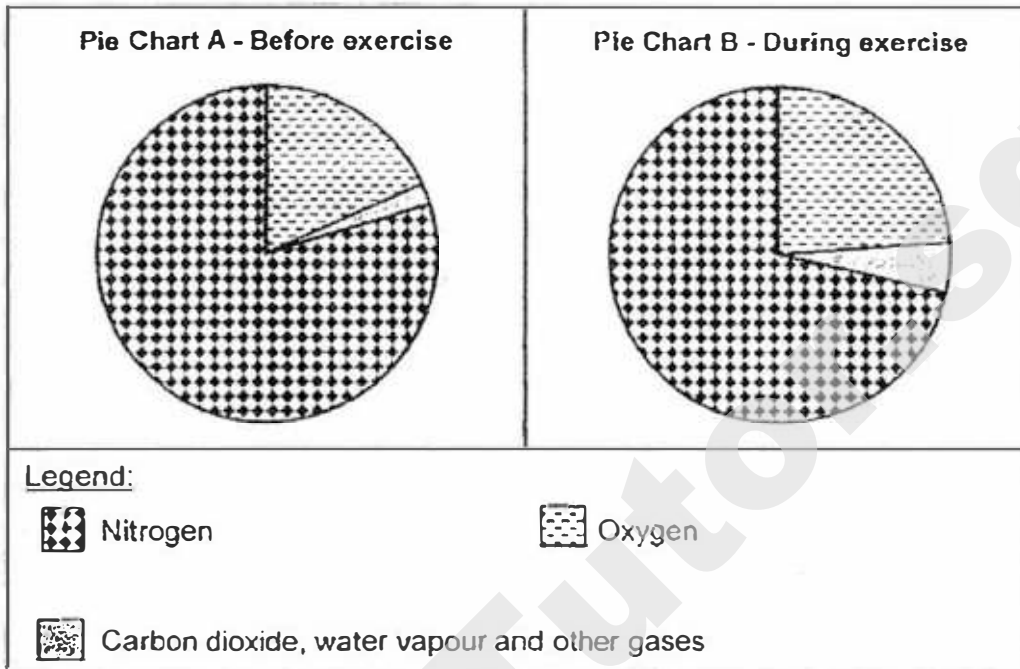

State 2 mistakes in the Pie Chart B. (2m)

Mistake 1:	There should not be a decrease in _____
Mistake 2:	There should not be an increase in _____

- b) The diagram below shows the human circulatory system.

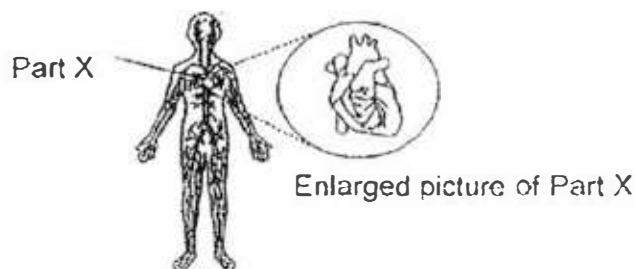

State the function of Part X. (1m)

32. Jack recorded the properties of 4 different types of materials as shown below.

Material	Breakable	Melting point	Flexibility
A	No	110 °C	No
B	Yes	50 °C	No
C	No	97 °C	Yes
D	No	43 °C	Yes

Jack wanted to use one of the materials above to make into a bowl for hot noodles at 85°C as shown in the picture below.



Noodles at 85°C

- a) Which material, A, B, C or D is the most suitable to be used to contain hot noodles? Explain your answer. (2m)

- b) Jack used a type of material to pack noodles as shown in the diagram below.

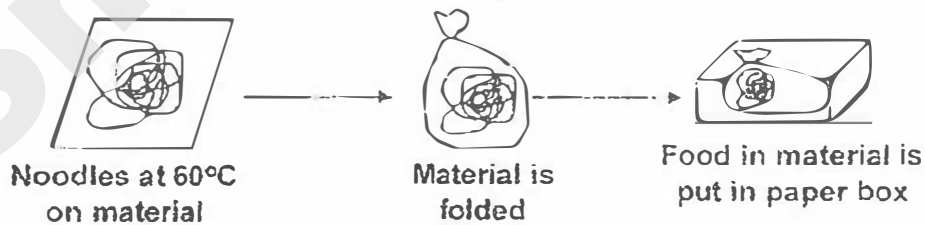

Explain why Material C will be a good choice to pack noodles at 60°C. (1m)



33a) Linda wanted to observe the plant transport system. Diagram 1 shows the stem of a plant. Diagram 2 shows the water-carrying and food-carrying tubes in the stem.

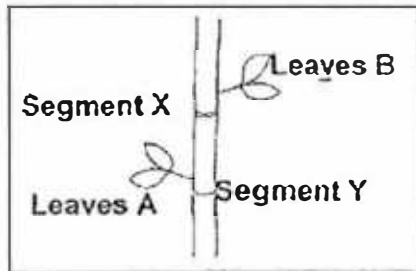

Diagram 1

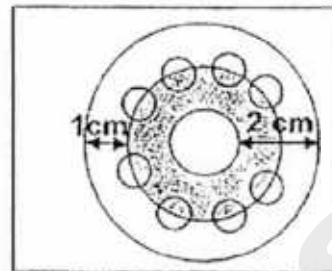
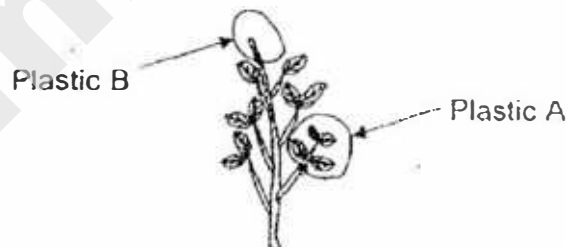

Diagram 2

i) Explain why Leaves A remained healthy when a 1 cm cut is made at Segment Y. (1m)

ii) Explain why Leaves B died when a 2 cm cut is made at Segment X. (1m)

b) Linda tied 2 plastic bags around a plant for 12 hours. Plastic Bag A is tied to some leaves and Plastic Bag B is tied to a branch without any leaves.



Linda observed that there were water droplets on the inner side of Plastic Bag A but there were no water droplets on the inner side of Plastic Bag B.

i) What can Linda conclude from the above experiment? (2m)



34. Lily observed the characteristics of 2 seeds, P and Q, as shown below.

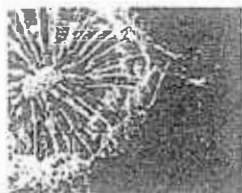

Seed from Plant P

- tiny and light
- has feathery-like structure



Seed from Plant Q

- Tiny and light
- Hard
- Surrounded by juicy flesh

a) She recorded how the speed of wind affected the distance travelled by the seeds, P and Q, as shown in the graph below. Write "Seed P" and "Seed Q" in the correct boxes in the graph below. (1m)

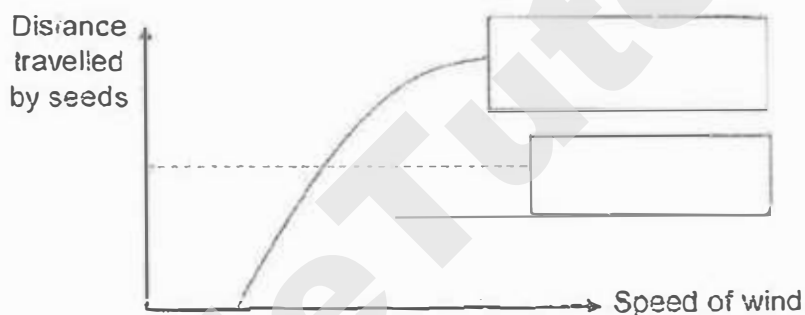

b) Two islands A and B are surrounded by water. The table below describes them further.

	Island A	Island B
Presence of animals	No	Yes
Presence of wind	Yes	Yes
Amount of sunlight	Sufficient	Sufficient

i) On which island, A or B will there more likely to have fewer Plant Q than Plant P? (1m)

ii) Plant W is not found on Island B and does not disperse by wind. Give 2 possible reasons why Plant W's seedling appear on Island B one year later. (2m)



- 35a) A kettle contains a metal coil which heats up the water in the kettle when the electricity is switched on. Paul uses 3 identical kettles, A, B and C with different metal coils as shown below.

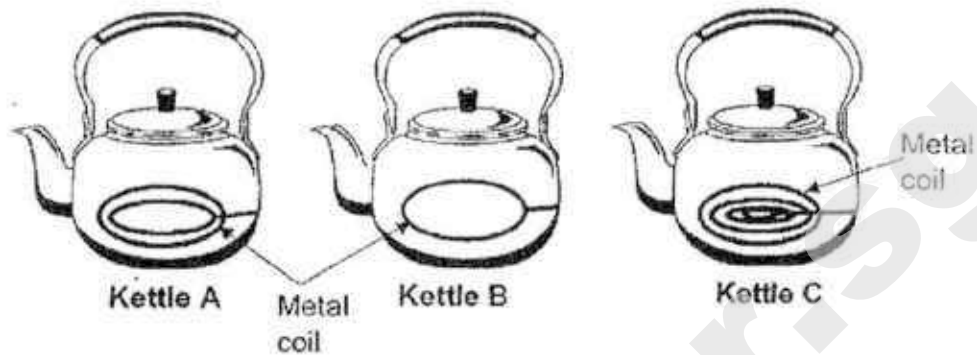

Paul poured an equal amount of water at 25°C into each kettle. He found that the water in Kettle C heated up the fastest. Give a reason for this. (1m)

- b) Paul poured water into 4 cups made of different materials, W, X, Y and Z. He recorded the time taken for the water to boil as shown in the graph below.

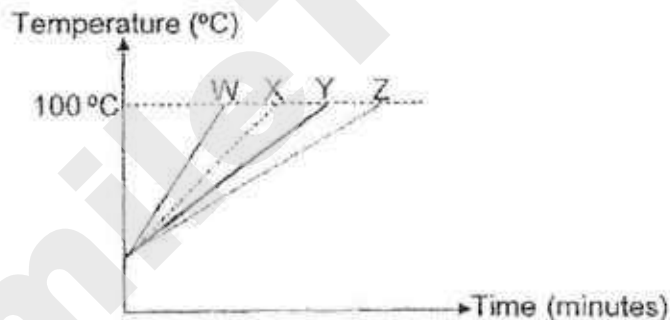

- i) Which Material, W, X, Y or Z is the poorest conductor of heat? (1m)

- ii) Explain why Material Z is the best material to make into a container for transporting ice. (2m)



- 36a) Sherlyn placed 2 identical wooden blocks in different positions directly under identical light sources in a dark room. Shadows were formed on Screens X and Y.

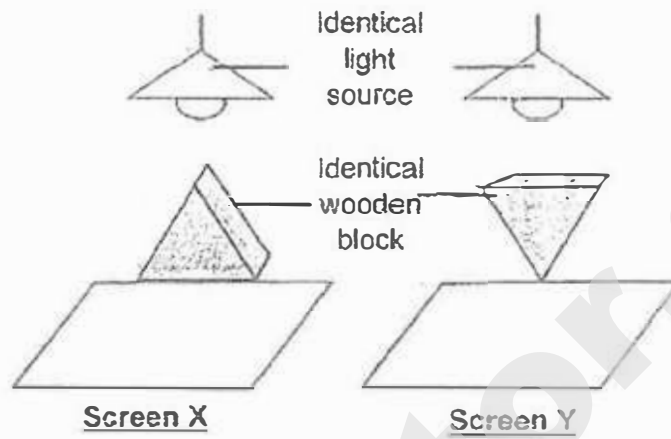

- i) Draw the shadows formed on screens X and Y. (1m)



- ii) Without moving the screen or changing the wooden blocks, state a way to increase the size of the shadow formed on the screen. (1m)

36b) Sherlyn recorded the amount of light that passed through Material R. She repeated the same experiment with materials S and P and recorded the results in the graph below.

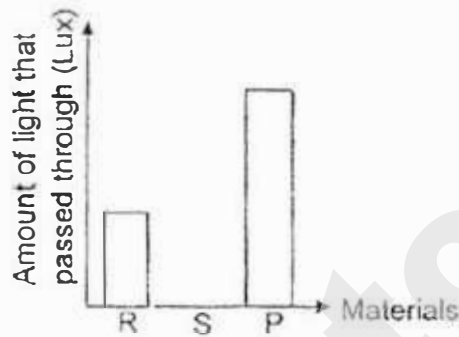
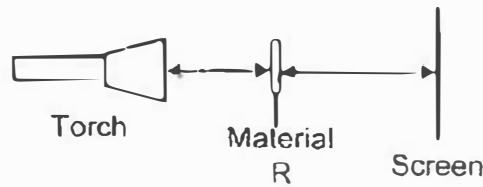

Next, she cut materials, R, S and P into different shapes as shown below.

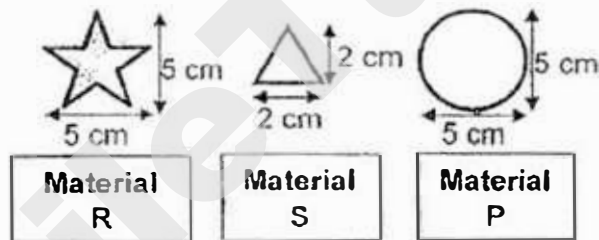

She then shone the torch through Materials R, S and P and drew the shadow formed on the screen as shown below.

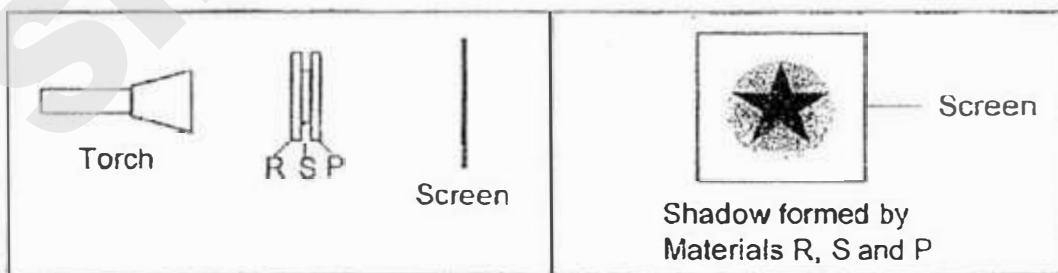

Explain why the shadow drawn is incorrect. (1m)



- 37a) Tommy wanted to find out the relationship between the number of bees in his garden and the number of fruits developed in his garden. He recorded the results in the table below.

Months	Number of bees	Number of fruits developed
January	234	15
March	341	18
June	651	21
September	423	19

- i) State the relationship between the number of bees in Tommy's garden and the number of fruits developed. (1m)

- ii) In the development of fruits, which process are the bees involved in? (1m)

- iii) In December, no bees were found in the garden but some fruits were developed. Give a possible reason why the fruits can still develop. (1m)



37b) The diagram below shows a flower.

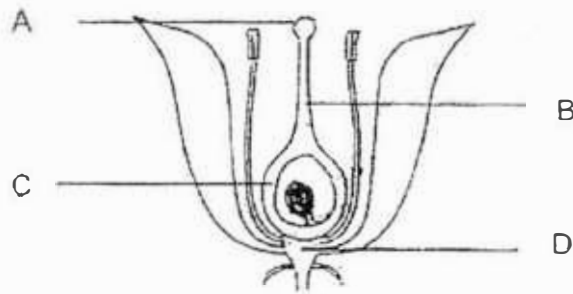

i) Which part, A, B, C or D will become a fruit? (1m)

ii) Tommy has removed petals and pollen of Flower A as shown below.

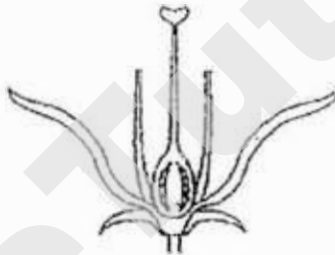

Flower A

Explain why Flower A can still become a fruit. (1m)

- 38a) Kelly placed containers, A, B, and C in an open garden. She filled each container completely with water and recorded the number of hours taken for the water to decrease by 50ml.

Container	Time taken to decrease by 50ml
A	25 hours
B	18 hours
C	38 hours

The diagram below shows 3 containers. Based on the results in the above table, fill in "A", "B" and "C" in the correct boxes below. (2m)

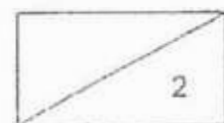
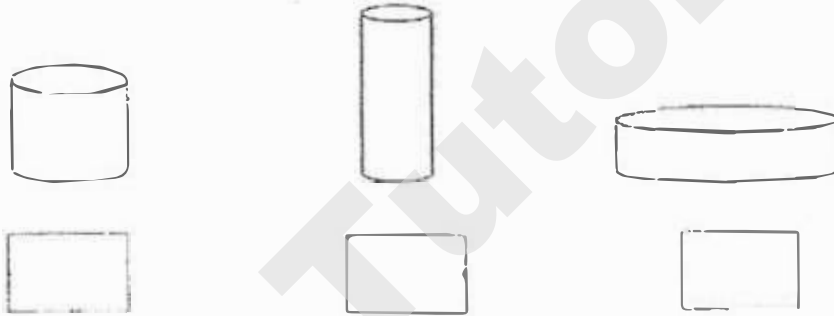

- 38b) Kelly conducted an experiment as shown below using set-ups, X and Y. Both containers are identical and filled completely with water.

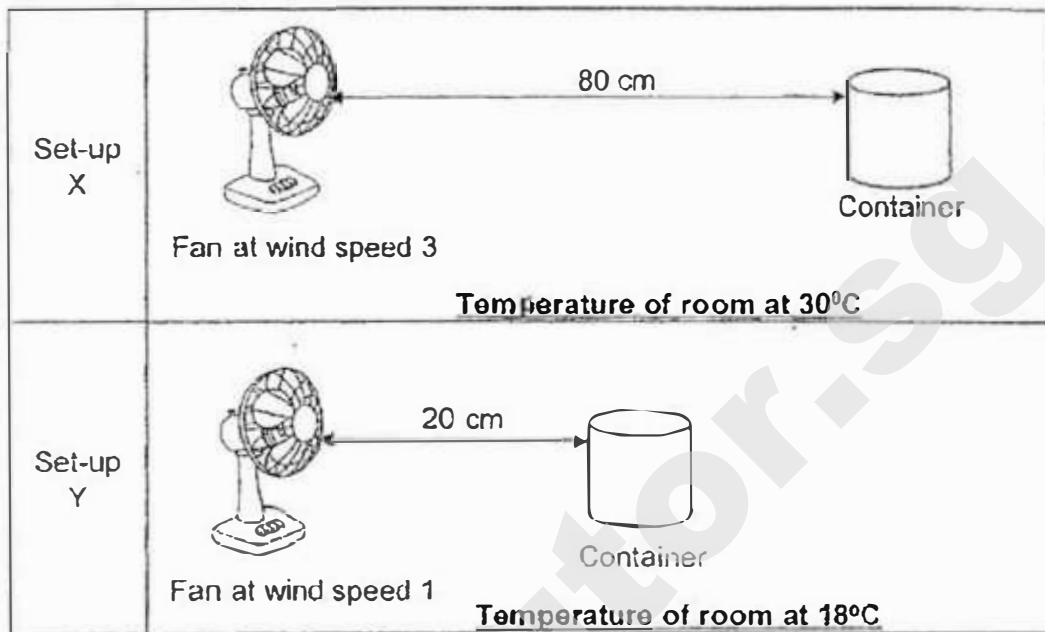

She recorded the results of her experiment as shown below.

Set-up	Amount of water left in container
X	150ml
Y	210ml

- i) Based on Kelly's experiment, explain why she was unable to conclude that the greater the wind speed of the fan, the faster the rate of evaporation. (1m)

- ii) Kelly wanted to find out how the distance between the fan and container of water affects the rate of evaporation. State 2 variables which Kelly should keep the same for her to conduct a fair test. (1m)

Variable 1 : _____

Variable 2 : _____



39. Sally has a special writing board that works as shown below.

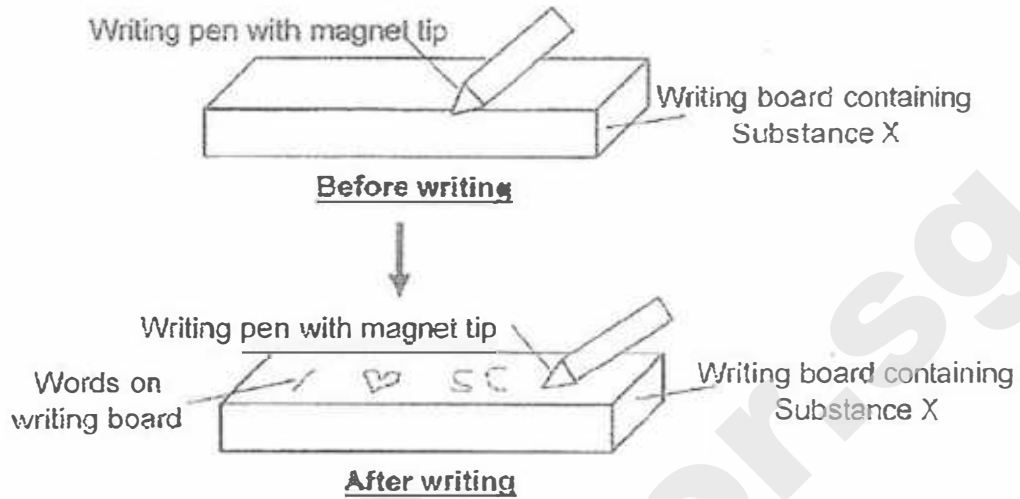

a) Explain how the words appear on the writing board. (1m)

b) Suggest a material which Substance X could be made of. (1m)

In order to remove the written words on the writing board, Sally placed Object A below the writing board. As Object A moves around the bottom of the writing board, the 'written' words would disappear.

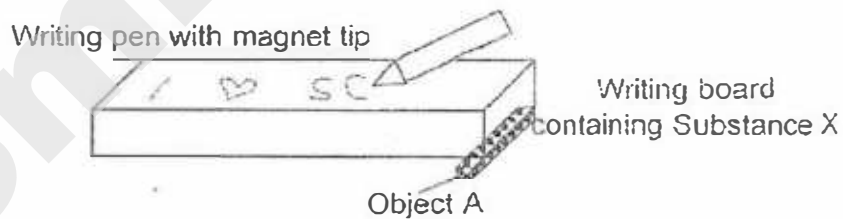

c) Explain why Sally is unable to remove the written words if Object A is made of aluminium. (1m)

40. Janice used 3 materials, X, Y and Z to conduct an experiment. She placed the materials in different conditions and observed the changes in their lengths as shown in the table below.

Material	Original length at 25°C (cm)	Length at 0°C (cm)	Length at 55°C (cm)
X	5	4.5	5.4
Y	7	6.7	8.1
Z	9	8.9	9.2

- a) Which material, X, Y or Z, expands the most at 55°C? (1m)

- b) Janice created a plate using Material Y and Z as shown below.

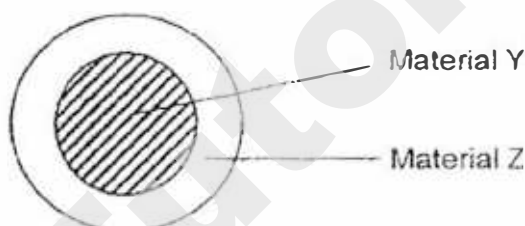



Explain why the plate will crack at 55°C. (2m)

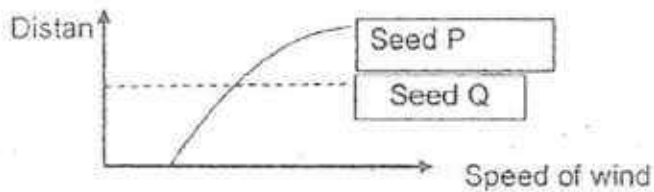

2017 P5 Science SA1 Answer Key

1)	2	6)	4	11)	4	16)	3	21)	4	26)	2
2)	4	7)	4	12)	3	17)	4	22)	2	27)	3
3)	2	8)	1	13)	2	18)	2	23)	2	28)	2
4)	2	9)	1	14)	4	19)	1	24)	1		
5)	1	10)	4	15)	2	20)	1	25)	4		

Qn	Suggested Answer
Q29a	Water droplets
Q29b	The warmer water vapour from the air <u>lost</u> heat and <u>condensed</u> onto the <u>cooler</u> air around the ice block.
Q29c	Increase the temperature of the room.
Q30a	QUESTION A: Does it have a <u>cell wall</u> ? QUESTION B: Does it have <u>chloroplasts</u> ?
Q30bi	Cell membrane
Q30bii	It would become bigger.
Q31a	Mistake 1: There should not be a decrease in <u>nitrogen</u> . Mistake 2: There should not be an increase in <u>oxygen</u> .
Q31b	To pump blood to other parts of the body .
Q32a	Plastic A. (1m) Its melting point is above 85°C(0.5) and is not flexible(0.5m).
Q32b	Its melting point is above 60°C and is flexible
Q33ai	The water-carrying tubes are not cut below Leaves A and Leaves A can still receive water.
Q33aii	Water carrying tubes are cut below Leaves B and Leaves B cannot receive water.
Q33b	i) It shows that plants give out water (vapour) through their leaves (which condensed as water droplets on the plastic bag).
Q34a	
Q34bi	Island A
Q34bii	Plant W could be dispersed by animals which fly or swim to Island B AND Plant W could be dispersed by water.
Q35a	C has the most coils / metal to heat up the water.
Q35bi	Z
Q35bii	Z. It is poorest conductor of heat. Z will conduct/ transfer heat from the

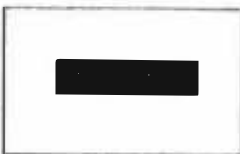
	surroundings to the ice the slowest.
Q36ai	<div style="display: flex; justify-content: space-around; align-items: center;"> <div style="text-align: center;">  <p>Screen A</p> </div> <div style="text-align: center;">  <p>Screen B</p> </div> </div>
Q36aii	Move the light source nearer to the wooden block. OR Move the wooden block away from the screen.
Q36b	Material S is opaque/does not allow light to pass through(0.5). There should be a black triangle in the shadow shown (0.5).
Q37ai	When the number of bees in Tommy's garden increases, the number of fruits developed will increase. (<i>Cause and effect cannot be reversed</i>)
Q37aii	Pollination
Q37aiii	Other insects / Wind can still help to pollinate the flowers/ transfer the pollen grains to the stigma.
Q37bi	C
Q37bii	Flower B can be pollinated by pollen grain from another flower of the same species and develop into a fruit.
Q38a	A, C, B
Q38bi	She changed two variables, the temperature of the room and the distance between the water and the fan, making the test unfair.
Q38bii	Variable : The wind speed Variable : Temperature of the room/ temperature of water Variable: Exposed surface area of water
Q39a	The magnetic tip of the pen attracts Substance X.
Q39b	Iron OR Steel
Q39c	Aluminium is (non-magnetic and) cannot be/ is not a magnet, thus it cannot attract Substance X. (<i>As an iron bar is a magnetic material but it also can't attract X if it is not made into a magnet, saying 'aluminium is non-magnetic' is not sufficient</i>)
Q40a	Material Y
Q40b	Materials Z and Y expanded at different rates.

Name : _____ ()

Class : Primary 5 _____

Primary 5

Semestral Assessment 1 – 2017

SCIENCE

BOOKLET A

9 May 2017

Total Time for Booklets A and B: 1 hour 45 minutes

**28 questions
56 marks**

**Do not open this booklet until you are told to do so.
Follow all instructions carefully.**

This paper consists of 20 printed pages.

Section A (28 x 2 marks = 66 marks)

For each question from 1 to 28, four options are given. One of them is the correct answer. Make your choice (1, 2, 3 or 4). Shade the correct oval (1, 2, 3 or 4) on the Optical Answer Sheet provided.

1. Study the flow chart below.

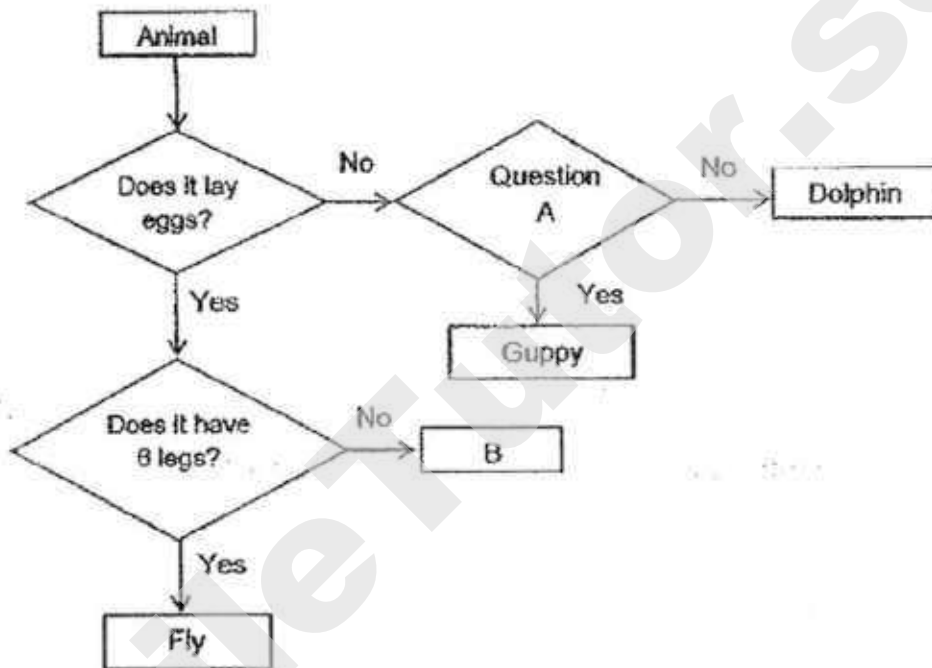

Which of the following correctly shows what Question A and animal B could be?

	Question A	B
(1)	Does it have hair?	Ladybird
(2)	Does it have scales?	Bat
(3)	Does it breathe through lungs?	Duck
(4)	Does it breathe through gills?	Spider

2. Study the table shown below.

Body System A	Body System B	Body System C
Heart	Nose	Mouth
Lungs	Gullet	Stomach
Blood vessels	Diaphragm	Large Intestine

Which of the above organs have been classified wrongly?

- (1) Lungs and stomach only
- (2) Lungs and gullet only
- (3) Gullet and mouth only
- (4) Diaphragm and mouth only

3. Which of the following statements is true for all amphibians?

- (1) They lay eggs.
- (2) They live on land only.
- (3) They live in water only.
- (4) They only breathe through their gills.

4. Meiling observed a seed as it germinated into a young plant. She recorded her observations as shown below.

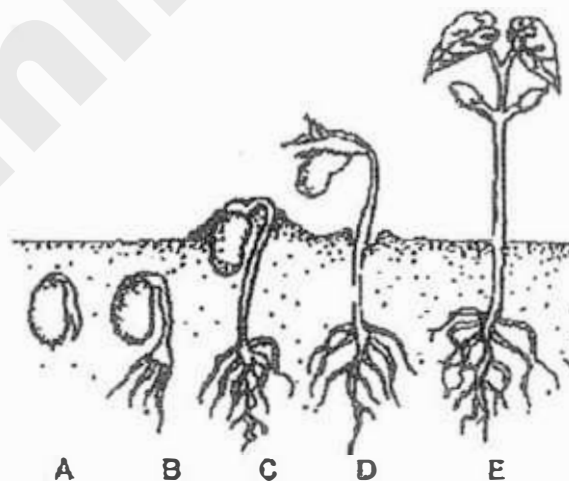

At which stages do the germinating seed take in oxygen?

- (1) A and B only
- (2) A, B and C only
- (3) C, D and E only
- (4) A, B, C, D and E

5. Which of the following comparisons between photosynthesis and respiration are correct?

	Respiration	Photosynthesis
A	Oxygen is produced	Oxygen is needed
B	Water is produced	Water is needed
C	Carbon dioxide is produced	Carbon dioxide is needed
D	Takes place all the time	Takes place where there is light

- (1) A and B only
- (2) B and D only
- (3) A, C and D only
- (4) B, C and D only

6. The graph below shows the number of days for each stage of the life cycle of organisms X and Y.

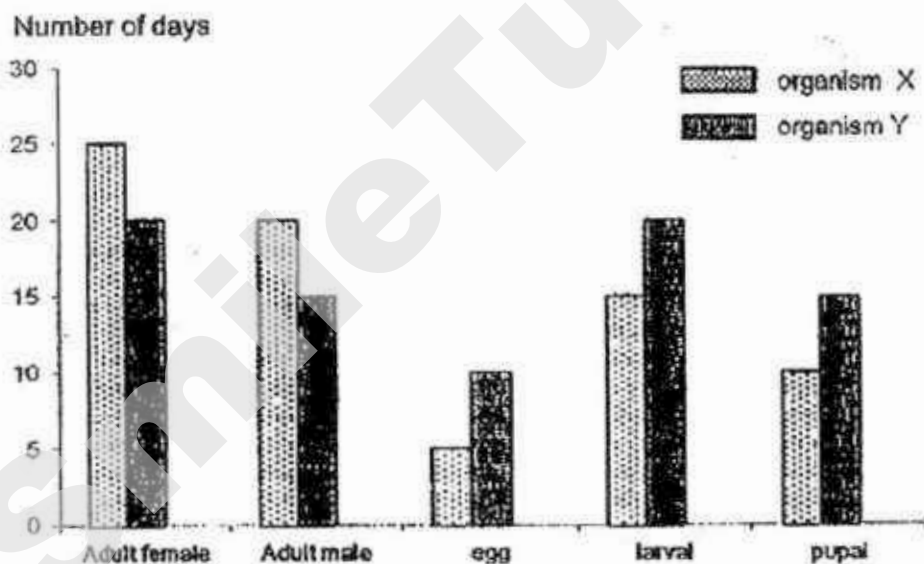

Which of the following shows the stages that organism X and Y would be on the 15th day after the eggs have been hatched?

	Organism X	Organism Y
(1)	larval	larval
(2)	larval	pupal
(3)	pupal	adult
(4)	adult	adult

7. Which of the following set-ups can be used to show that plants take in water?

(1)

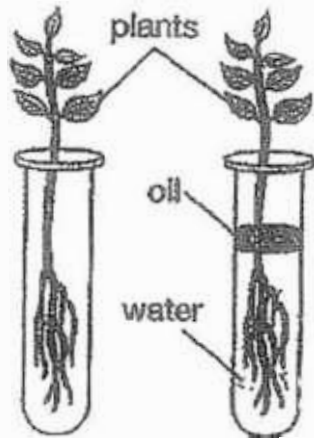

(2)

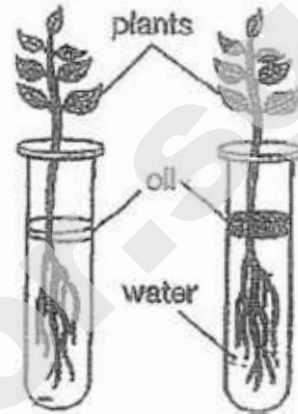

(3)

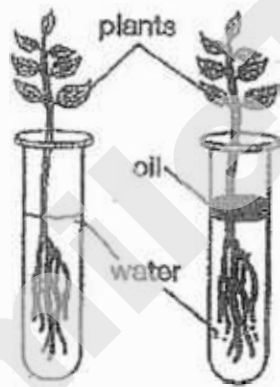

(4)

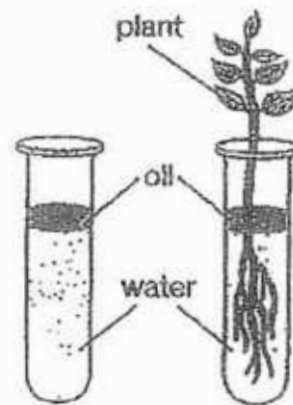

8. The graph below shows the changes in the composition of air in a lift where five people are trapped in.

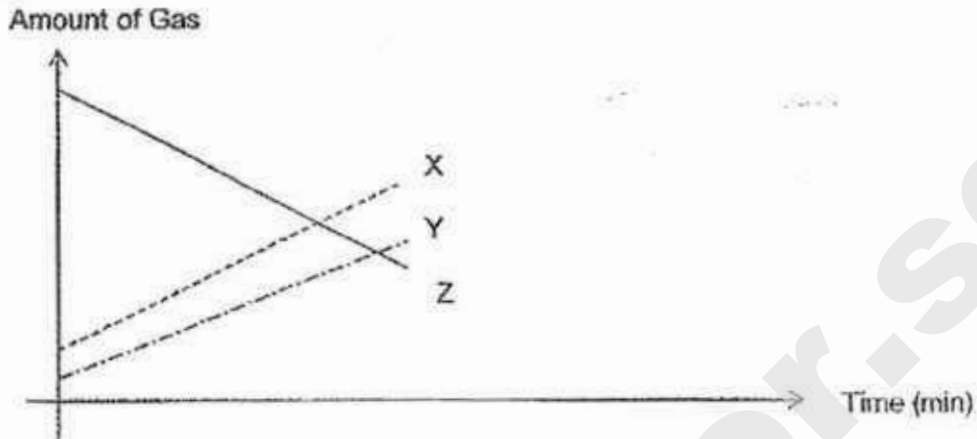

What gases do X, Y and Z represent?

	X	Y	Z
(1)	oxygen	water vapour	carbon dioxide
(2)	carbon dioxide	water vapour	oxygen
(3)	nitrogen	carbon dioxide	oxygen
(4)	carbon dioxide	oxygen	water vapour

9. The gills of a fish consist of feather-like gill filaments as shown below.

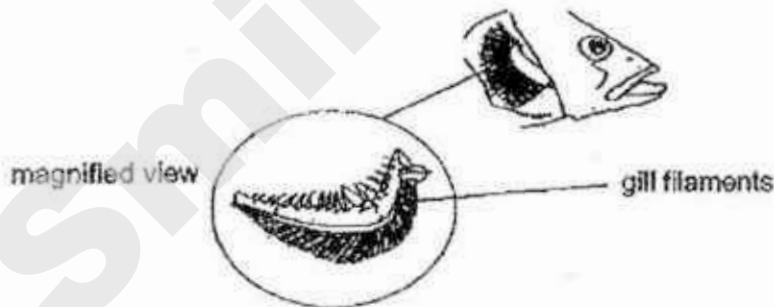

The gill filaments of the fish have many blood vessels to _____.

- A: allow gaseous exchange to take place at a faster rate.
- B: increase the surface area in contact for the absorption of oxygen.
- C: absorb dissolved carbon dioxide from the water at a faster rate.
- D: allow dissolved carbon dioxide to pass from the bloodstream to the water.

- (1) A and B only
- (2) B and C only
- (3) A, B and C only
- (4) A, B and D only

10. The diagram below represents a magnified view of an air sac and a blood vessel in a human body.

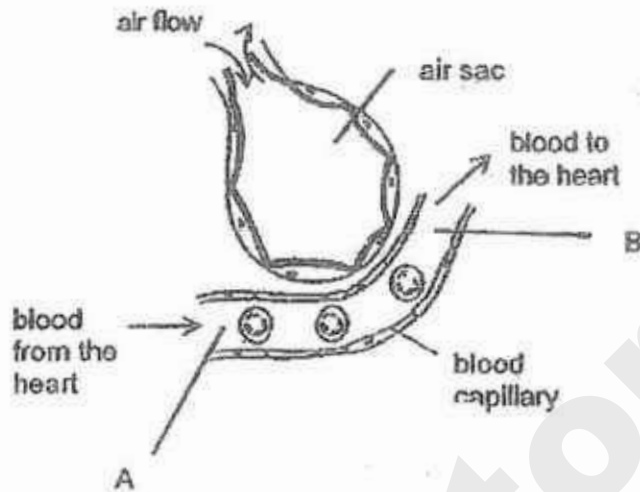

Which one of the following correctly describes the level of carbon dioxide in A and B?

	A	B
(1)	High	High
(2)	Low	High
(3)	High	Low
(4)	Low	Low

11. The table below shows the boiling points and melting points of 4 different substances P, Q, R and S.

Substance	Boiling point ($^{\circ}\text{C}$)	Melting point ($^{\circ}\text{C}$)
P	20	-5
Q	78	15
R	105	23
S	178	50

Which of the substances P, Q, R and S, are in liquid state at 28°C ?

- (1) P and S only
 (2) Q and R only
 (3) P, Q and R only
 (4) Q, R and S only

12. The diagram below shows how food and various gases are transported in the human body

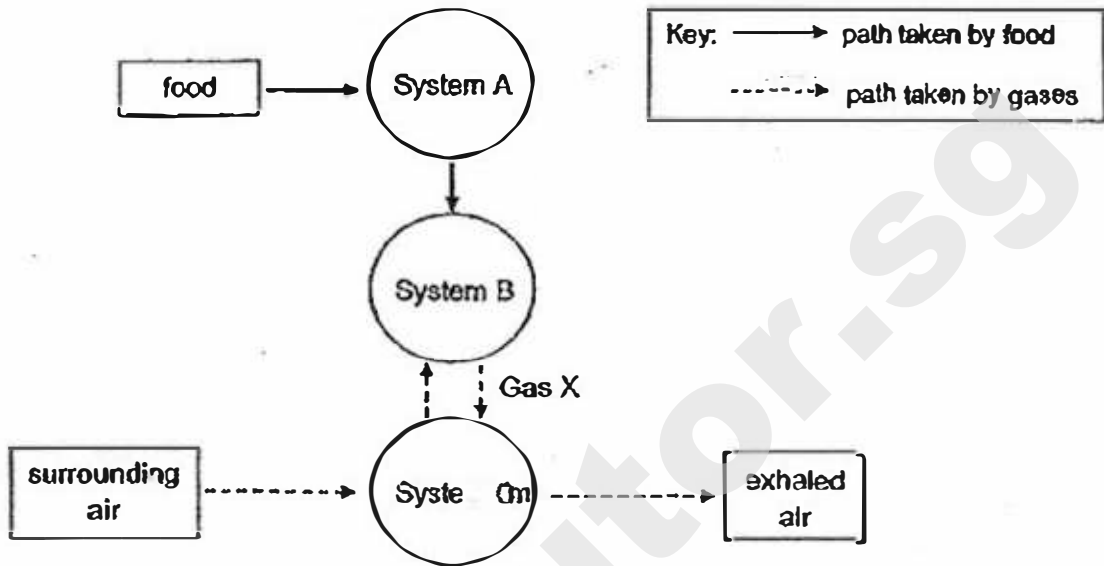

Which systems do P, Q and R represent and what is gas X?

	System A	System B	System C	Gas X
(1)	circulatory	respiratory	digestive	carbon dioxide
(2)	digestive	circulatory	respiratory	carbon dioxide
(3)	circulatory	digestive	respiratory	oxygen
(4)	respiratory	circulatory	digestive	oxygen

13. Which one of the following diagrams shows how food is transported in a plant?

(1)

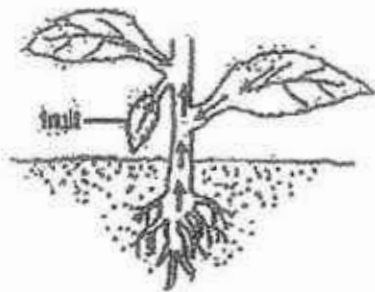

(2)

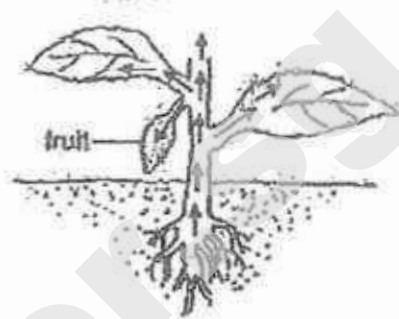

(3)

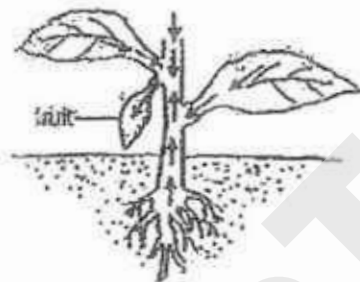

(4)

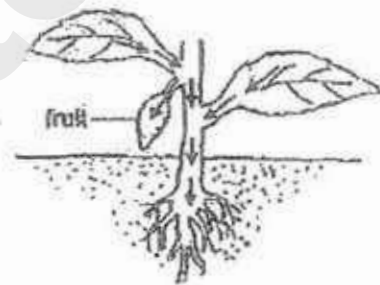

14. The diagram below shows a cross-section of a stem.

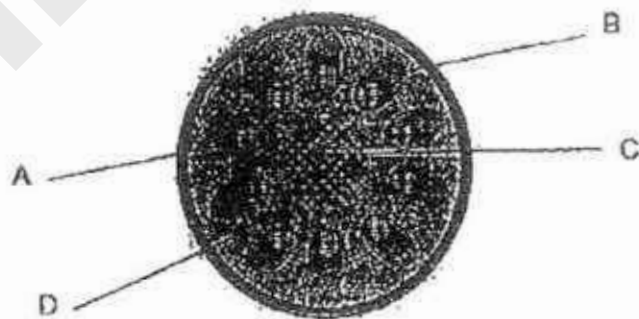

An aphid is found to be feeding on food made by the plant during photosynthesis. Which part of the stem will the aphid most likely insert its feeding tube into?

- (1) A only
- (2) B only
- (3) B and D only
- (4) A, B and C only

15 The chart below shows how four cells W, X, Y and Z, are classified.

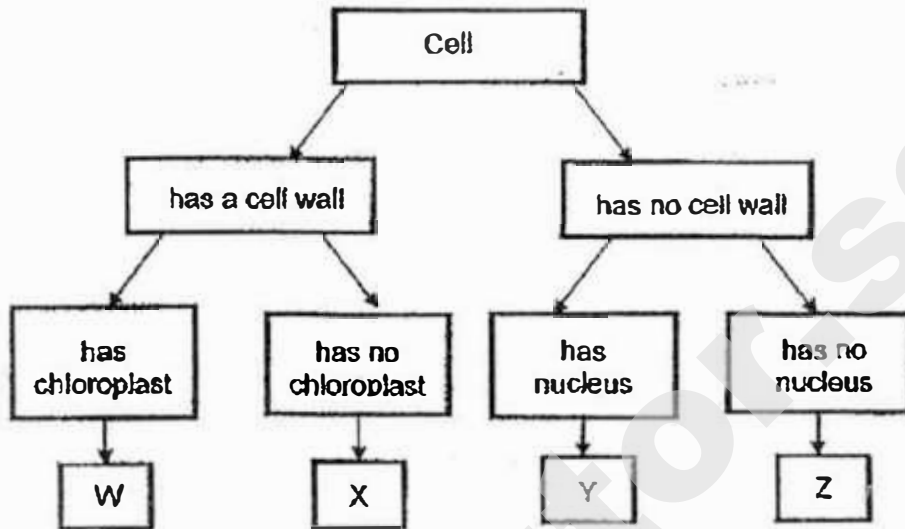

Which of the following statements are true?

- A: Cell Z has a regular shape.
- B: Cell W can trap sunlight.
- C: Cell Y can be taken from the cheek.
- D: Cells W and X can be found in the leaf of the plant.

- (1) A and C only
- (2) A and D only
- (3) B and C only
- (4) B and D only

16. Study the diagram below.

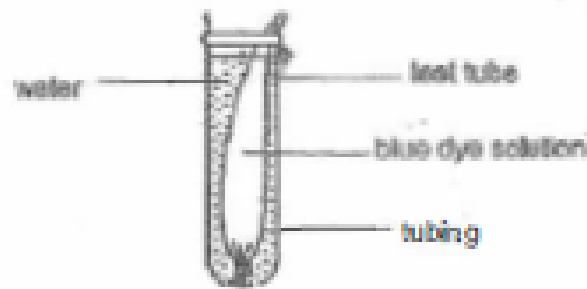

Which of the following explains why the size of the tubing becomes bigger after some time?

- (1) The tubing is fully permeable and allows water particles to pass through.
 - (2) The tubing is fully permeable and allows the blue dye particles to pass through.
 - (3) The tubing is semi-permeable and allows the water particles to pass through but the blue dye particles are too large to move out of the tubing.
 - (4) The tubing is semi-permeable and allows both the particles of water and blue dye to move out of the tubing.
17. Johnson suspended 4 magnets A, B, C and D, above a tray of pins. The result is shown below.

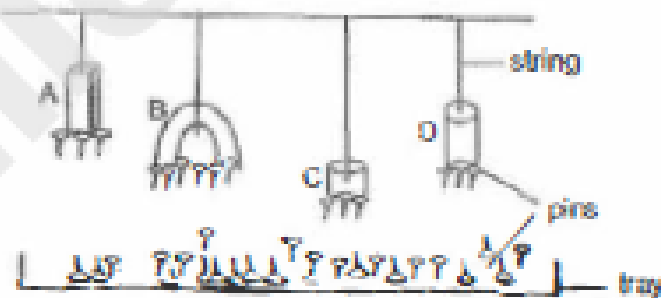

What can you conclude from the result of his experiment?

- (1) A is weaker than B.
- (2) A is stronger than D.
- (3) C is stronger than D.
- (4) B is the strongest magnet.

18. Study the flow chart below.

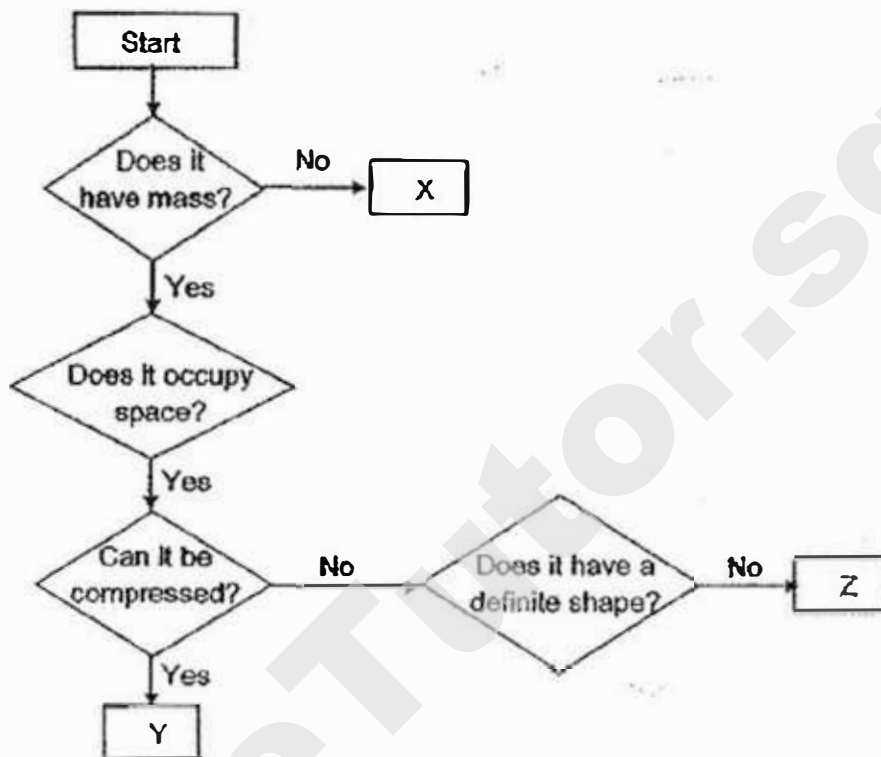

Which one of the following correctly identifies X, Y and Z?

	X	Y	Z
(1)	shadow	oxygen	sand
(2)	ice	nitrogen	flour
(3)	light	water vapour	milk
(4)	steam	air	soap

19. An experiment was conducted to test the strength of four different materials M, N, O and P. Weights of the same mass were hung on the different materials until they snapped.

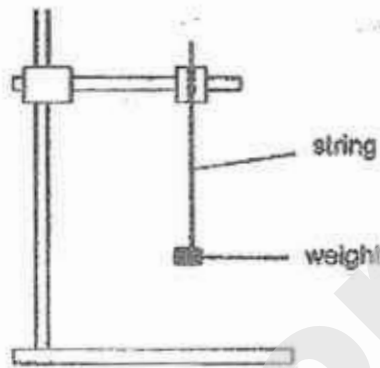

Results of the experiment are recorded in the table below.

Material	M	N	O	P
No. of weights before the material snapped	15	23	10	8

Which one of the following shows the correct order of strength for materials M, N, O and P from the weakest to the strongest?

	Weakest			Strongest
(1)	P	O	M	N
(2)	P	M	O	N
(3)	N	O	M	P
(4)	N	M	O	P

20. Alsha set up a circuit as shown below. She observed that only bulb A lit up. She then exchanged X with Y and observed that no bulb lit up.

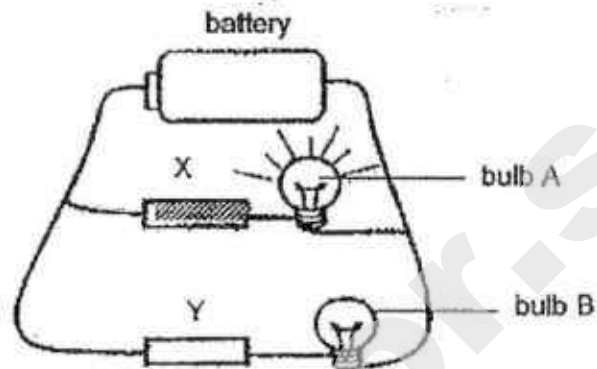

Which one of the following is correct?

	Electrical Insulator	Bulb not working
(1)	X	A
(2)	X	B
(3)	Y	A
(4)	Y	B

21. Bulbs A, B and C lit up when they were connected as shown below.

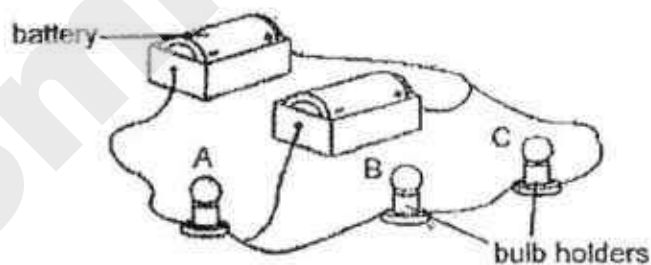

What will happen to bulbs A and B if bulb C is removed from the bulb holder?

- (1) Both bulbs A and B will not light up.
- (2) Bulb A will light up but bulb B will not.
- (3) Bulb A will give out a brighter light than bulb B.
- (4) Bulb B will give out a brighter light than bulb A.

22. Alex set up the following circuit with four materials W, X, Y and Z, of similar size.

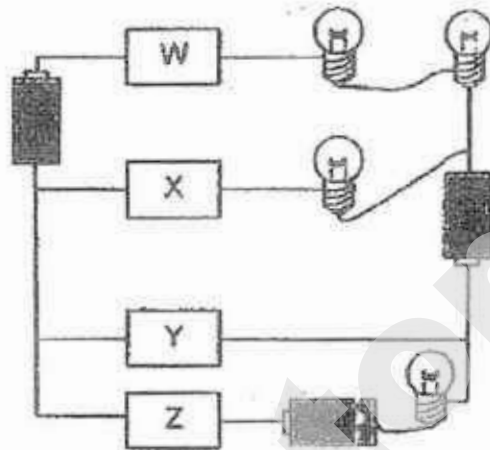

He observed that only one bulb was lit. Which one of the following is correctly represented by materials W, X, Y and Z, in the above circuit?

	Material W	Material X	Material Y	Material Z
(1)	aluminium	glass	porcelain	copper
(2)	silver	copper	glass	steel
(3)	silver	iron	copper	aluminium
(4)	porcelain	aluminium	iron	plastic

23. The diagram below shows a circuit tester and a circuit card. A, B, C, D and E are paperclips on the circuit card. Wires connecting some of the paper clips are concealed.

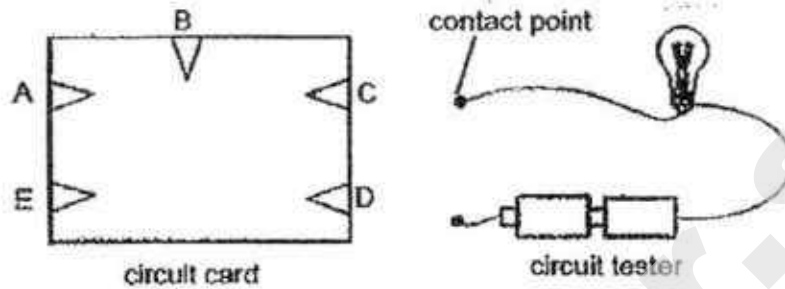

The table below shows the results obtained when the contact points on the circuit tester are connected to different pairs of paper clips on the circuit card shown above.

Pair of connected paperclips	Does the bulb light up?
A and C	No
A and D	No
B and C	Yes
B and D	Yes
B and E	Yes
D and E	Yes

Based on the results shown in the table above, which one of the following shows the correct connection of the wires behind the circuit card?

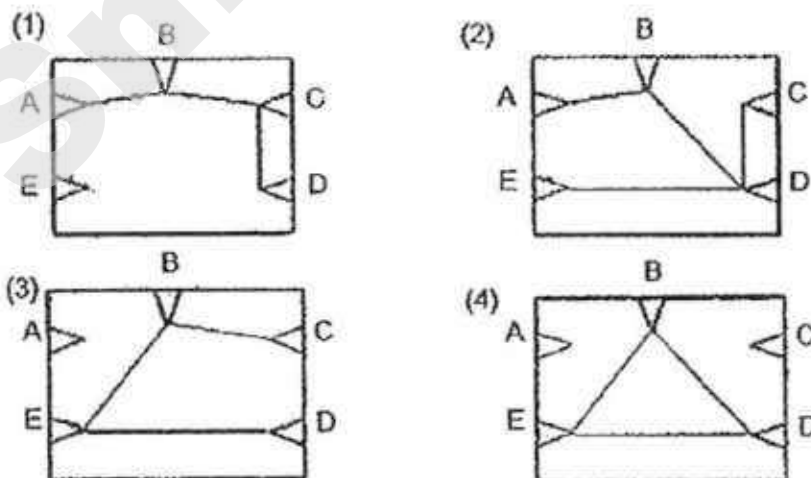

24. Martin carried out an experiment in a dark room. He arranged 4 sheets made of different materials S, T, U and V, in a straight line as shown below. When the torch was switched on, he observed that a bright patch of light in the shape of a star was seen on sheet U only.

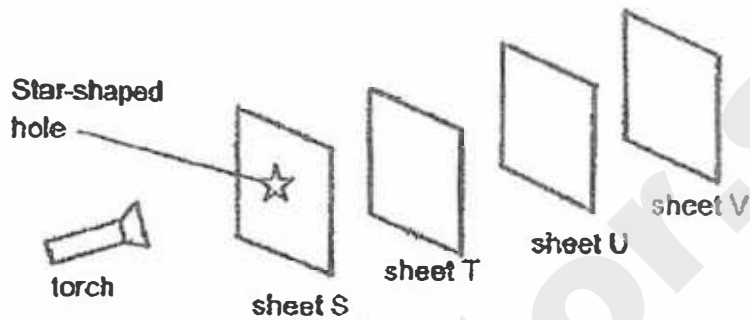

Which of the following statements is/are true about the sheets used above?

- A: Sheet S is opaque.
- B: Sheet T is transparent.
- C: Sheet U is translucent.
- D: Sheet V is opaque.

- (1) A only
- (2) A and B only
- (3) B and D only
- (4) B, C and D only

25. Samy carried out an experiment with the set-up shown below.

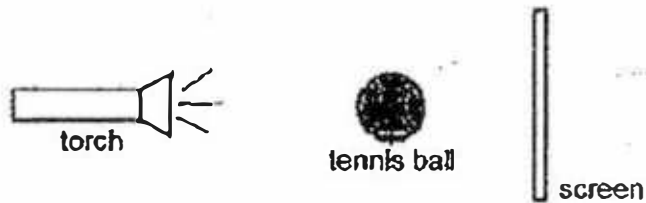

He wrote down what he did for his experiment.

- A Switch on the torch.
- B Measure the height of the shadow of the tennis ball cast on the screen.
- C Move the tennis ball 5 cm closer to the torch.
- D Measure the height of the shadow again.
- E Repeat steps (C) and (D) twice, moving the tennis ball 5 cm closer to the torch

Which one of the following statements is the correct hypothesis for his investigation?

- (1) The bigger the screen, the bigger the size of the shadow cast.
- (2) The brightness of the torch will affect the size of the shadow.
- (3) The distance between the torch and the tennis ball will affect the height of the shadow.
- (4) The distance between the torch and the screen will affect the height of the shadow.

26. Susila wanted to find out how the temperature of water affects the rate at which sugar dissolves. She used sugar cubes of similar size and 4 identical beakers to set up her experiment. Details of her experiment are shown in the table below.

Beaker	Number of sugar cube	Temperature of water (°C)	Amount of water (ml)
W	2	90	600
X	1	30	600
Y	1	90	500
Z	1	40	500

Which beakers should Susila compare?

- (1) W and X
- (2) W and Y
- (3) Y and Z
- (4) X and Y

27. A group of students carried out an experiment using a beaker of ice cubes. They heated the beaker of ice cubes and then left it on a table to cool. They observed the changes in temperature at regular intervals and plotted a graph as shown below.

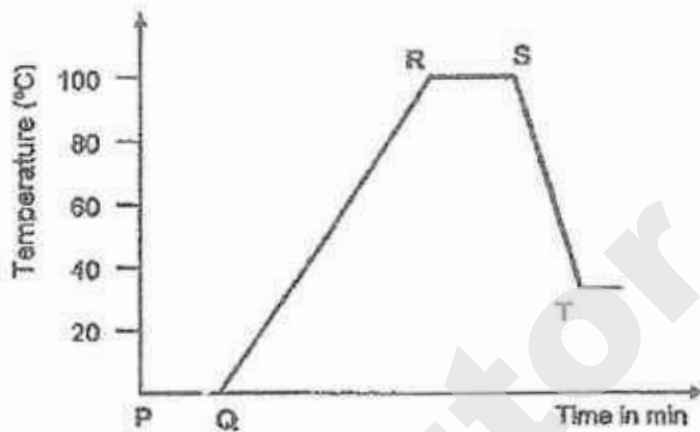

Which part(s) of the graph PQ, QR, RS, ST show(s) heat gained during their experiment?

- (1) QR only
- (2) ST only
- (3) PQ and QR only
- (4) PQ, QR and RS only

28. Ben filled two identical metal cans X and Y, with 150 cm^3 of water at $80 \text{ }^\circ\text{C}$. Next, he wrapped a strip of metal P around can X and a strip of metal Q around can Y, as shown in the diagram below. The metal strips were of the same length and thickness.

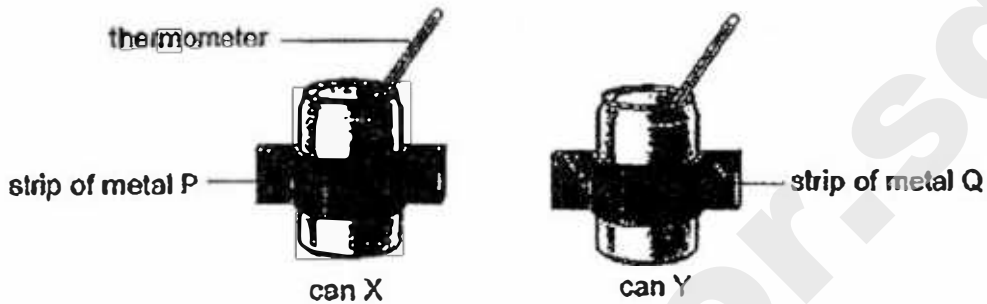

Ben recorded the temperature of the water in each can at 5-min intervals for 20 minutes in the table below.

Time (min)	Temperature of water in the can ($^\circ\text{C}$)	
	X	Y
0	80	80
5	64	60
10	53	49
15	51	48
20	48	43

Which of the following statements are correct?

- A Can Y is a better conductor of heat than can X.
- B Metal Q is a better conductor of heat than metal P.
- C The temperature of water in can Y drops more quickly than that in can X.
- D The water in can X gains heat more quickly from the surroundings than the water in can Y.

- (1) A and B only
- (2) B and C only
- (3) C and D only
- (4) A, B and C only

~~ End of Section A ~~

Name : _____ ()

Class : Primary 5 _____

Primary 5

Semestral Assessment 1 – 2017

SCIENCE

BOOKLET B

9 May 2017

Total Time for Booklets A and B: 1 hour 45 minutes

13 questions
44 marks

Do not open this booklet until you are told to do so.
Follow all instructions carefully.
Answer all questions.

This booklet consists of 18 printed pages.

Booklet A	56
Booklet B	44
Total	100

Parent's Signature/Date

Section B (44 marks)

For questions 29 to 41, write your answers in this booklet.

The number of marks available is shown in the brackets at the end of each question or part question.

29. John planted an equal number of similar bean seeds in 3 trays and placed them under different temperatures shown below. The seeds were provided the same amount of sunlight, the same type of garden soil and watered with the same volume of water daily for six days.

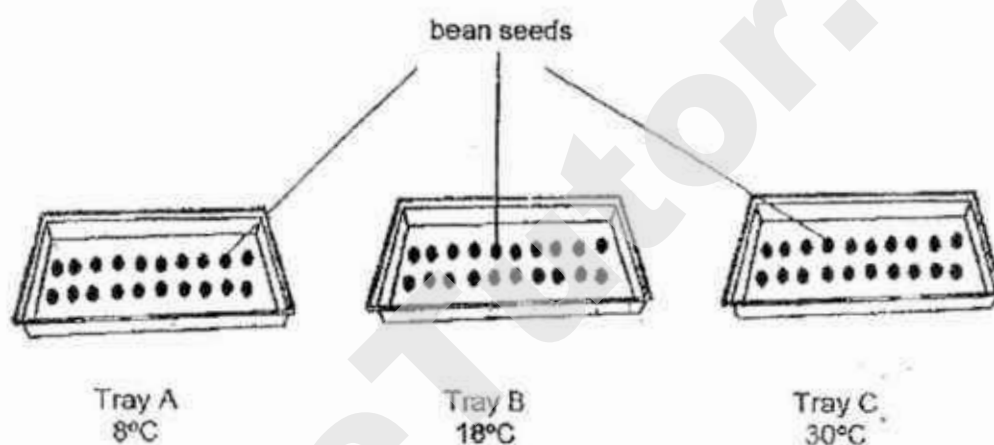

The results are shown in the table below.

Tray	Temperature (°C)	Total number of seeds germinated					
		Day 1	Day 2	Day 3	Day 4	Day 5	Day 6
A	8	0	0	0	0	1	1
B	18	0	0	0	1	4	6
C	30	0	5	8	13	17	20

- (a) What was the aim of the experiment?

[1]

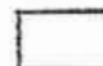

(b) Based on the results in the table, indicate with a tick (✓) whether each of the statement is True, False or Not Possible To Tell.

[2]

Statements	True	False	Not Possible To tell
The temperature of 8 °C was too cold for the seeds to germinate.			
All types of seeds germinate best at the temperature of 30 °C.			
The earliest germination was observed in seeds placed at the temperature of 30 °C.			
The seeds would not germinate above the temperature of 30 °C.			



30. Rita studied the life cycle of organism W shown below.

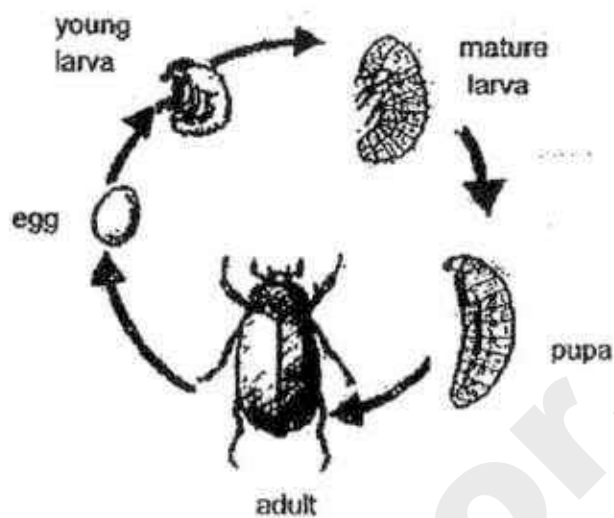

(a) Organism W is an insect. Give 2 reasons to support this statement.

[1]

Reason 1 :

Reason 2 :



- (b) Rita studied the effect of surrounding temperature on the life cycle of organism W. Her findings are shown below.

Temperature (°C)	Number of days for one complete life cycle
15	48
20	22
25	15
30	9
35	7

- (i) Based on Rita's findings, how would temperature affect the length of one complete life cycle of organism W. [1]

- (ii) Organism W lays its eggs which hatch into larvae in decaying animal bodies. The larvae grow in size after some time. Suggest and explain 2 benefits for organism W when it lays its eggs in decaying animal bodies. [2]

Benefit 1 :

Benefit 2 :



31. Study the flow chart below.

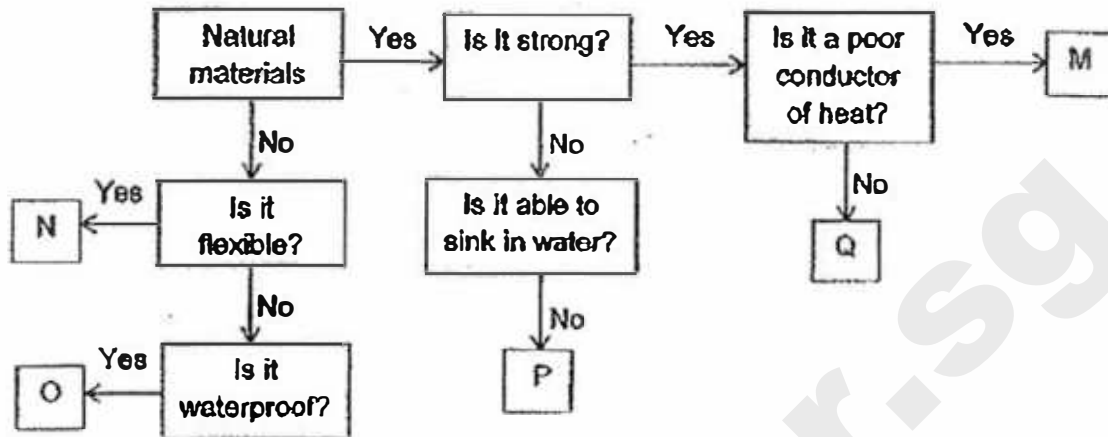

(a) Based on the flow chart above, write the letter M, N, O and P in the boxes that best represent the objects shown in the box below. [2]

	Objects	Letter
(i)	Car tyre	
(ii)	Raincoat	
(iii)	Wooden chopsticks	
(iv)	Ceramic pot	

(b) State all the characteristics of object Q. [1]



32. Edward discovered cell A in a sample of pond water shown below. Upon microscopic examination, he noticed that cell A moves about using its tail-like structure called flagellum.

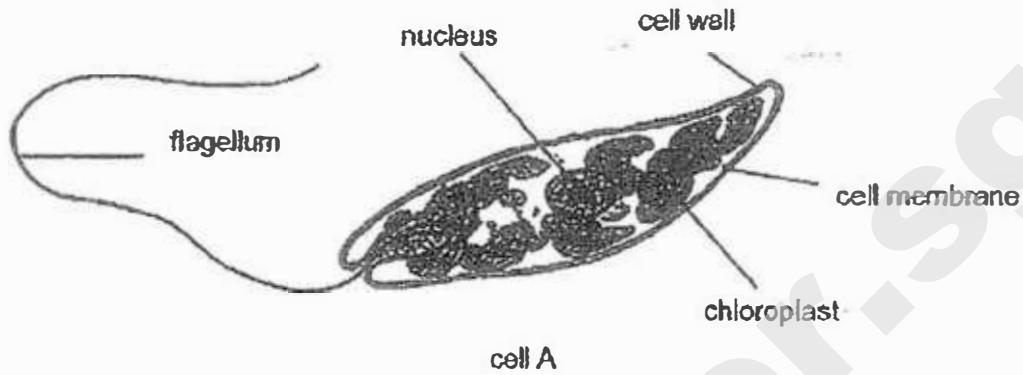

- (a) Based on the diagram, Edward thinks that cell A is more likely to be a plant cell than an animal cell. Explain why. [2]

- (b) Would cell A need to depend on other organisms for food? Explain your answer. [1]



33. Ravi measured the breathing rates of various age groups of children (between 4 to 16 year olds) at rest. His findings are plotted in a graph shown below.

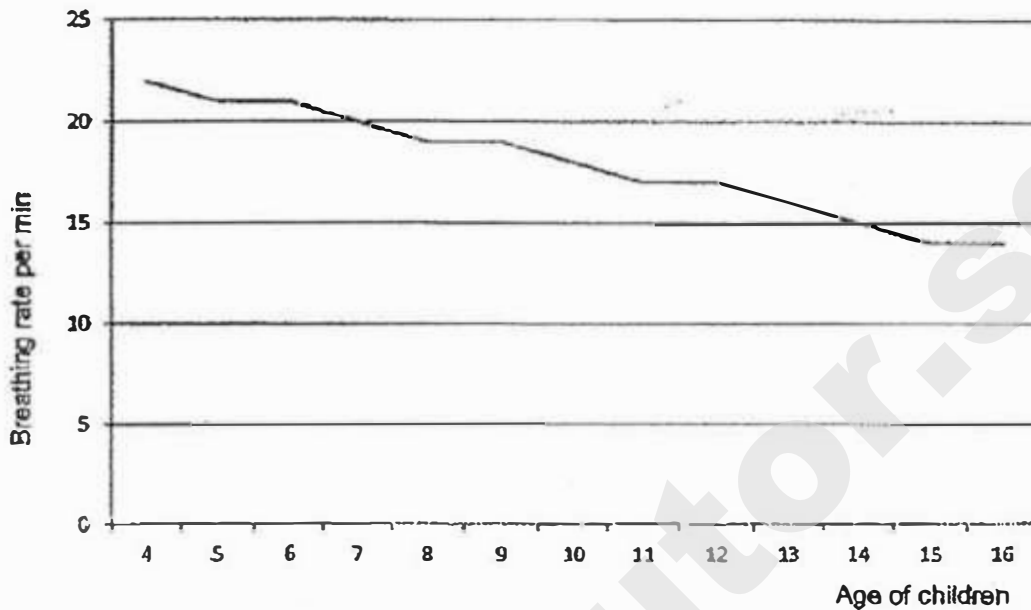

(a) What is the relationship between the breathing rate and the age of the children? [1]

(b) These children were allowed to run for 10 minutes. Ravi measured their breathing rates again and found that all their breathing rates have increased. Explain why. [1]

(c) Which system in the human body is similar to the transport system of a plant? [1]



34. Jovi placed a healthy plant in a beaker of red-coloured water as shown below. He sealed the top of the beaker with some aluminium foil. Two days later, Jovi observed that the flowers had turned red.

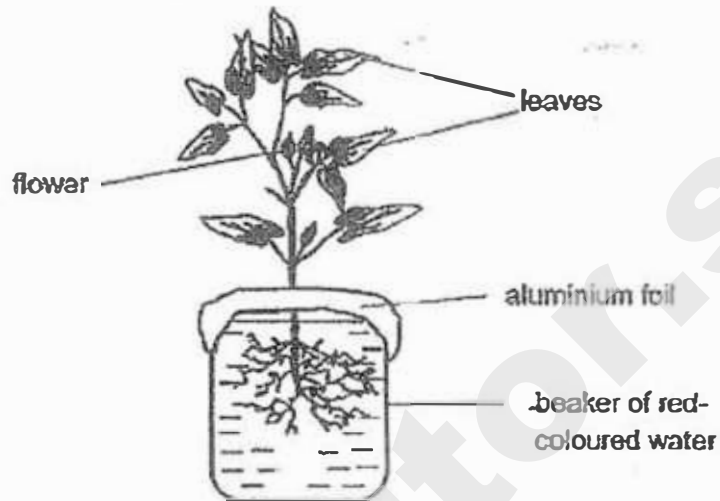

- (a) Explain why the flowers turned red? [1]

- (b) Jovi repeated the experiment with a similar set-up, but without the aluminium foil. [1]
Would the flowers in the second set-up turn red too? Explain your answer.



35. Siew Choo set up the experiment below to find out how water plants affect the percentage of dissolved carbon dioxide in water at different times of the day.

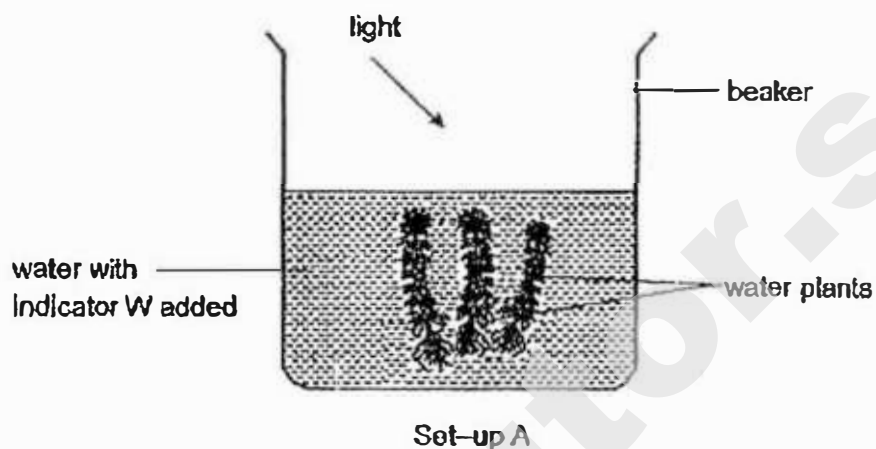

She placed set-up A near a window and added a few drops of indicator W to the beaker of water. Indicator W changes colour according to the percentage of dissolved carbon dioxide in the water as shown in the table below.

Percentage of dissolved carbon dioxide in water	Less than 0.03%	Normal (0.03%)	More than 0.03%
Indicator W colour change	purple	red	yellow

- (a) Write down the colour of the water. [1]
- (i) At 12.30 pm, in the afternoon: _____
- (ii) At 11.30pm, at night: _____

- b. Siew Choo repeated the experiment by adding some fish to a similar set-up B shown below.

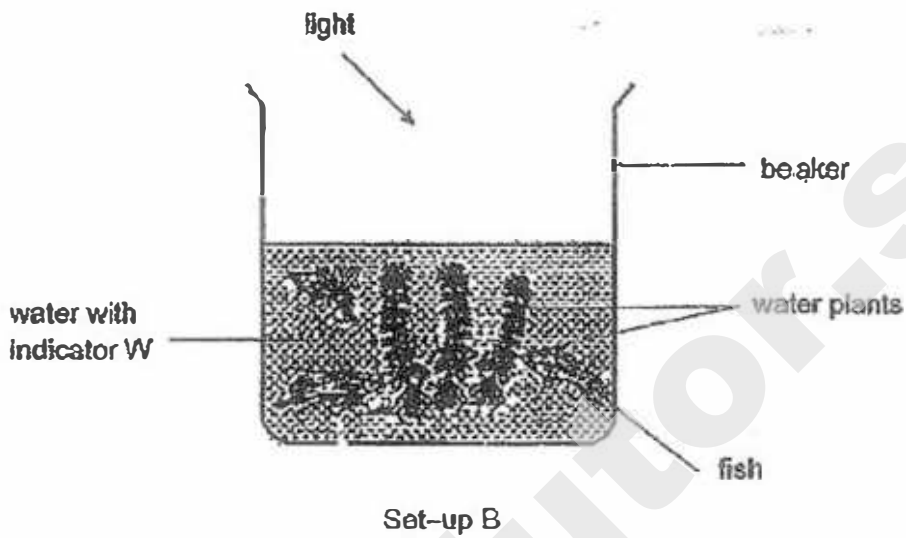

- (f) She predicted that the colour of the water at 12.30 pm for set-up B would be yellow [2] because there would be more dissolved carbon dioxide in the water. Explain why her prediction may not be correct.



36. Edison pushed an empty inverted bottle without a cap, vertically down into a basin of water as shown below. He noticed that the water level in the basin had risen.

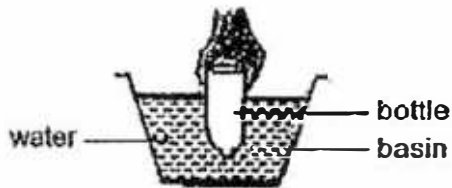

- (a) State another observation that he would likely see. Explain your answer. [2]

Next, he tilted the inverted bottle at an angle under water as shown below.

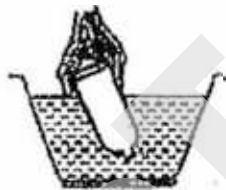

- (b) State one observation Edison would likely see. [1]

- (c) Explain Edison's observation in (b) [1]



37. The bulbs and batteries in the circuit below are identical.

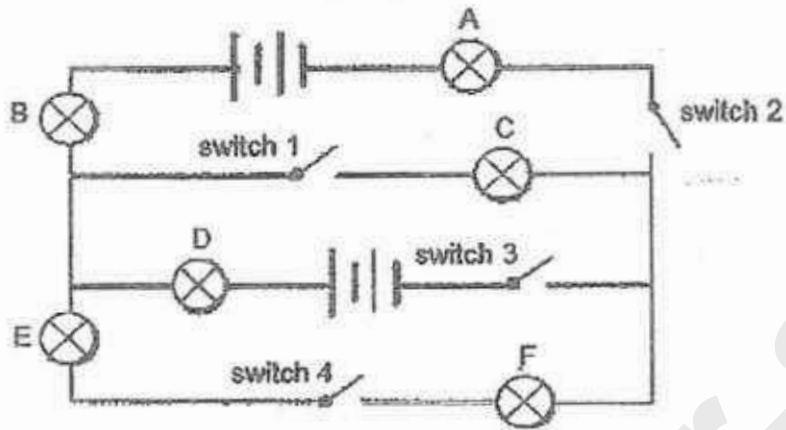

Complete the table below by writing the total number of bulbs that will light up when the stated switches are closed. [2]

Switches that are closed	Bulb(s) that light up
S1 & S4	
S1 & S3	
S2 & S3	
S2 & S4	



38. Study the circuit diagram below carefully. Three different materials A, B and C, were placed at positions 1, 2 and 3 as shown. All the bulbs were identical and functioning properly prior to the experiment

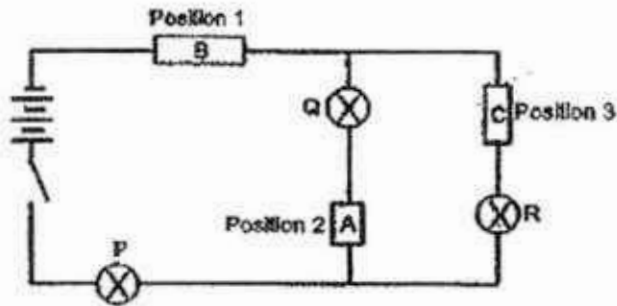

- (a) When the circuit was closed, it was observed that only bulb Q did not light up. Give one possible reason. [1]

The positions of materials A, B and C were then rearranged as shown below.

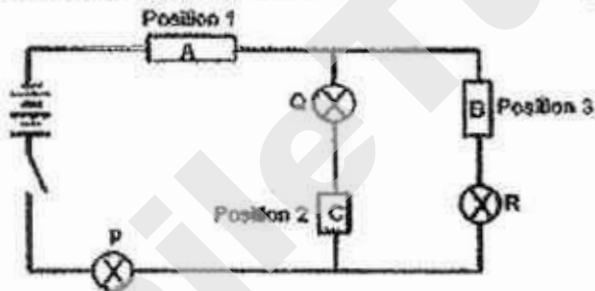

- (b) Write the words lit or unlit in the correct boxes below to indicate whether bulbs P, Q and R will light up when the circuit was closed. [2]

Bulb		
P	Q	R

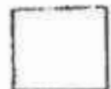

39. The diagram below shows a model of a solar water heater. A water pump is used to circulate the water in the set-up. The plastic water tank and plastic tube are filled with cold water. The tray is left in the sun while the plastic water tank is kept in the shade.

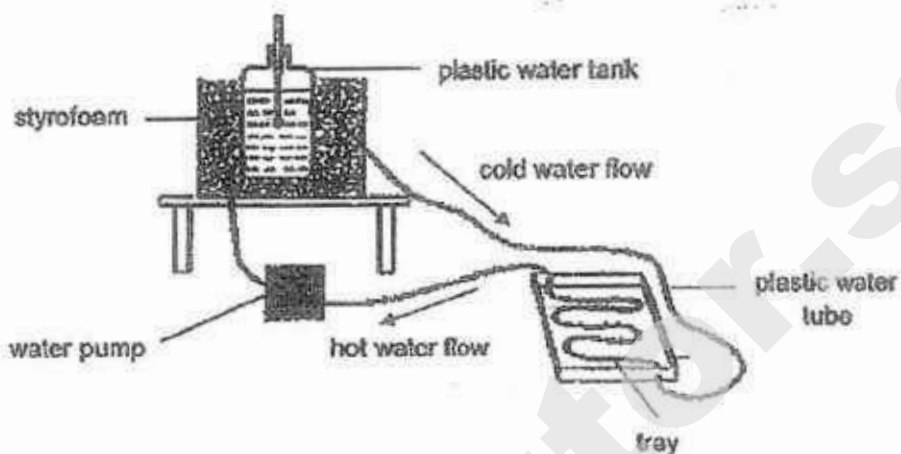

- (a) Name a suitable material for making the tray. Give a reason for your choice. [1]

- (b) What is the purpose of the styrofoam around the plastic water tank? [1]

- (c) Suggest another material to replace the styrofoam in the set-up. [1]

- (d) If we increased the number of coils on the tray without changing the length of the plastic tube, water could be heated up faster. Do you agree? Explain your answer. [2]



40. Kevin conducted an experiment to find out how the amount of light reflected by three different materials A, B and C, is affected by the distance the material is away from the light source.

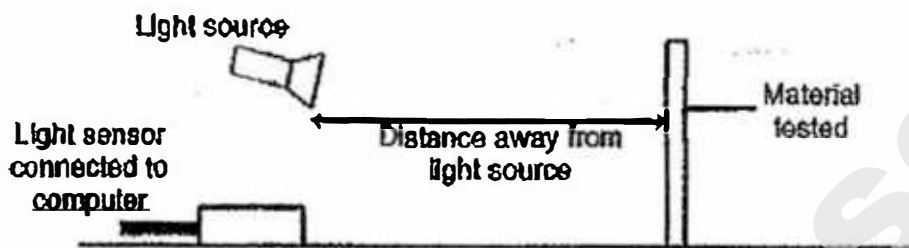

Kevin placed the materials A, B and C at different distances away from the light source and he used a light sensor to determine the amount of light that was reflected.

He recorded the results and plotted the results in the graph below.

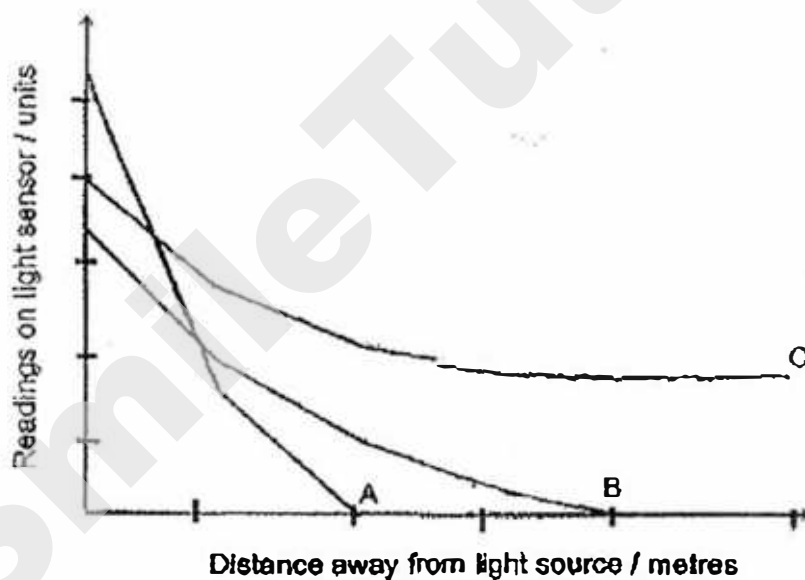

- (a) Explain why Kelvin should conduct his experiment in a dark room to ensure a fair test. [1]



- (b) State two variables that Kevin would have to keep constant to ensure a fair test.

- (c) Based on the results of his experiment, which material A, B and C, would be most suitable for making safety road signs for motorists to warn them of danger on the roads in the night? Explain your answer. [2]

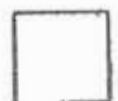

41. Each of the three metal bars A, B and C, was suspended with a string as shown in the diagram.

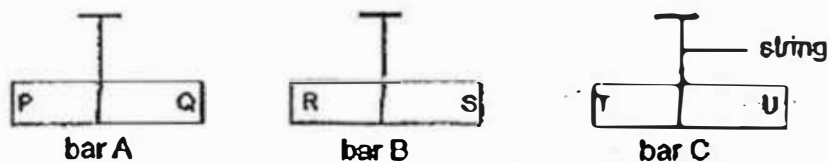

Diagram 1 below shows what happened when bars A, B and C were brought together.

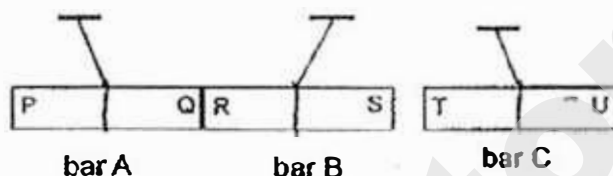

diagram 1

Diagram 2 below shows what happened when bar A and bar C were brought together.

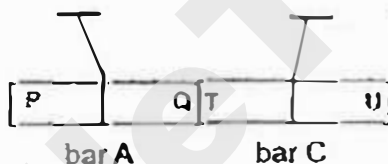

diagram 2

Based on the results above, state whether each of the following statements is True (T) or False (F). [4]

	Statement	True or False
A	Ends S and T are like poles.	
B	Ends P and U are unlike poles.	
C	Only bars B and C are magnets.	
D	Bar A is made of a non-magnetic material.	

— End of Paper —



EXAM PAPER 2017 (P5)

SCHOOL : CHIJ ST

SUBJECT : SCIENCE

TERM : SA1

Q1	Q2	Q3	Q4	Q5	Q6	Q7	Q8	Q9	Q10
4	2	1	4	4	1	4	2	1	3
Q11	Q12	Q13	Q14	Q15	Q16	Q17	Q18	Q19	Q20
2	2	4	2	3	3	2	3	1	4
Q21	Q22	Q23	Q24	Q25	Q26	Q27	Q28		
1	4	3	2	3	3	4	2		

29)a)To find out whether the temperature surroundings affect the rate of germination of the seeds.

b)False

Not Possible To Tell

True

Not Possible To Tell

30)a)Reason 1:Insects have 6 legs and organisms W has 6 legs.

Reason 2:Insects have 3 body parts and organisms W has 3 body parts.

b)i)The lower the surrounding temperature,the more more days need for one complete life cycle of organisms W.

ii)Benefit 1:There will be enough food as the larvae can feed on decaying animal bodies.

Benefit 2:It is not easy for the predators to find the young of organisms W inside the decaying animal so they will not be eaten up easily.

31)a)i)M

ii)N

iii)P

iv) O

b)Object Q is a natural material,it is strong and it is a good conductor of heat.

32)a)Cell A has chloroplast and cell wall.Plant cells have chloroplasts and cell wall while animal cells do not.

b)No,cell A would not need to.It has chloroplast that contains chlorophyll and traps sunlight for the plant to make food.

33)a)The older the children ,the lower the breathing rate per minute.

b)More energy is needed during the run so the breathing rate increases to take in more oxygen and remove more carbon dioxide for higher respiration rate. 33)c) Circulatory System

34)a)The roots absorbed the red-coloured water and the water carrying tubes transported it to the other parts of the plants.

b)Yes,the flowers in the second set-up would turn red too.The roots can still absorb the red-coloured water and the water carrying tubes will transport it to other parts of the plant.

35)a)i)Purple

ii)Yellow

b)i)In set-up B ,even though the fish give out carbon dioxide but the plants also take in carbon dioxide for photosynthesis.The amount of carbon dioxide absorbed by the plant may be higher than the amount of carbon dioxide given out by the fish.Thus the colour of the water will not be yellow.

36)a)Some water entered the bottle.Air can be compressed.

b)The water level will drop and the water will flow into the bottle.

c)When it is tilted ,some air in the bottle will escape so water could enter to occupy the space.

37)S1&S4-None

S1&S3-Bulbs C and D

S2&S3-None

S2&S4-Bulbs A,B,E and F

38)a)Material A is an electrical insulator and it does not allow electric current to pass through.

b)P-unlit

Q-unlit

R-unlit

39)a)Steel.It is a good conductor of heat.

b)Styrofoam is a poor conductor of heat so the hot water in the tank will lose heat slower to the surroundings to keep it warmer for longer period of time.

c)Rubber

d)Yes.When the number of coils on the tray increased ,there will be more surface area in contact with the tray, so that the water in the tubes will gain heat faster and get heated up faster.

40)a)To ensure that light that shines on the material is only from the light source and not from the surrounding.

b)The amount of light and the thickness of the material.

c)Material C.It is able to reflect the most light from the furthest distance.Thus it will be able to reflect the most amount of light off material C into the motorists' eye from the greatest distance.

41)A-True

B-False

C-True

D-False

SmileTutor.sg

Anglo-Chinese School (Junior)



SEMESTRAL ASSESSMENT 2 (2017)

PRIMARY 5

SCIENCE

BOOKLET A

THURSDAY

2 November 2017

1 HOUR 30 MINUTES

Name : _____ ()

Class : P5 _____

INSTRUCTIONS TO PUPILS

DO NOT TURN OVER THE PAGES UNTIL YOU ARE TOLD TO DO SO

Follow all instructions carefully.

There are 25 questions in this booklet.

Answer ALL questions.

INFORMATION FOR PUPILS

The total marks for this booklet is 50.

The total time for Booklets A and B is 1 hour 30 minutes.

This question paper consists of 20 printed pages (inclusive of cover page).

Booklet A (50 marks)

For each question from 1 to 25, four options are given. One of them is the correct answer. Make your choice (1, 2, 3 or 4). Shade your answer on the Optical Answer Sheet. (25 x 2 marks)

1. The table below provides some information on the characteristics of organisms A, B and C.

A tick (✓) in the box indicates the presence of the characteristics.

Organisms	Feeds on dead matter	Reproduces from spores	Makes its own food
A			✓
B	✓	✓	
C		✓	✓

Which of the following represents organisms A, B and C?

	A	B	C
(1)	Fern	Lemon Tree	Mould
(2)	Lemon Tree	Mushroom	Fern
(3)	Mushroom	Mould	Lemon Tree
(4)	Mould	Fern	Mushroom

2. Remus germinated a seed and recorded the observations in the table as shown below.

Observations	Day
Seed becomes swollen	1
Seed coat breaks	4
Roots start to appear	6
Shoots start to appear	9
Seed leaves finally drop off	16

On which day will the seedling most probably be able to photosynthesise?

- (1) 1
 (2) 4
 (3) 8
 (4) 15

3. The diagram below shows the cross-section of a flower. Karen has identified some parts of the flower and recorded the name and function of each part of the flower in the table below.

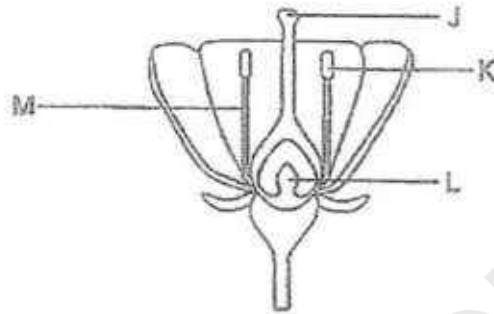

Part	Name of part	Function
J	Stigma	It produces the female sex cells.
K	Anther	It produces the male sex cells.
L	Style	It receives the pollen grains.
M	Filament	It supports the anther.

Which of the above names of parts and functions match the labelled parts correctly?

- (1) J and L only
- (2) K and M only
- (3) L and M only
- (4) J, K and L only

4. Study the flow chart below carefully.

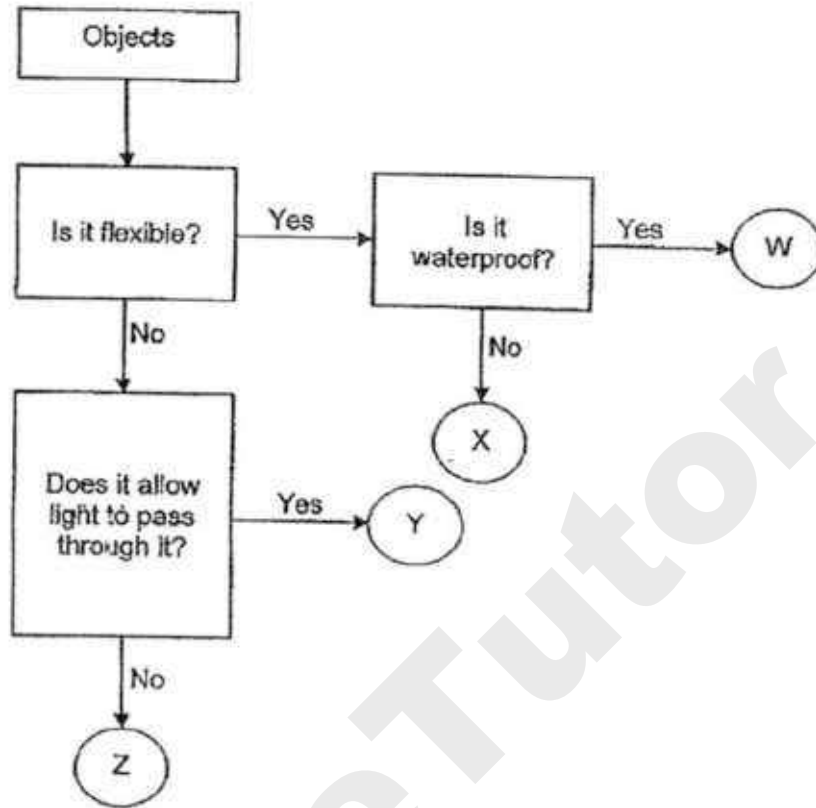

Which of the following correctly represents objects W, X, Y and Z?

	W	X	Y	Z
(1)	Raincoat	Shirt	Window pane	Brick
(2)	Shirt	Raincoat	Brick	Window pane
(3)	Window pane	Brick	Raincoat	Shirt
(4)	Brick	Window pane	Shirt	Raincoat

5. Which of the following statements about the life cycles of a butterfly and a frog is/are incorrect?

- A Both life cycles have three stages.
- B Both of their young live in water during the early stages.
- C The butterfly gives birth to live young but the frog lays eggs.
- D The life cycle of a butterfly has a pupa stage but the life cycle of a frog does not have a pupa stage.

- (1) D only
- (2) B and D only
- (3) A, B and C only
- (4) A, C and D only

6. Kenneth wants to find out if the number of coils of wire around an iron nail affects the strength of the electromagnet. An iron nail becomes an electromagnet when it is placed in a coil of wire joined to batteries in a closed circuit.

Arrangement	Number of batteries	Number of coils of wire around iron nail
P	2	30
Q	1	20
R	4	30
S	2	50

Which two arrangements below should he set up to carry out his investigation?

- (1) P and R
- (2) P and S
- (3) R and Q
- (4) Q and S

7. The diagram below shows a container with Substance P placed in different positions as shown below.

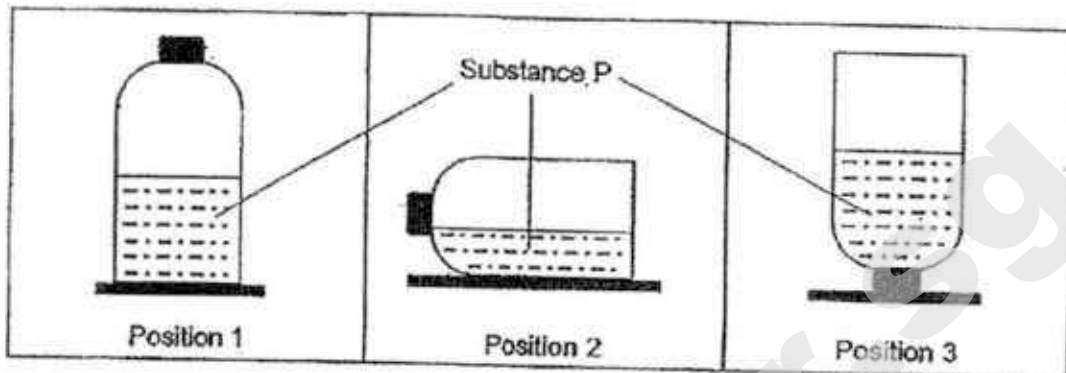

Based on the diagram, what can you conclude about substance P?

- W P takes up space.
- X P can be compressed.
- Y P does not have a definite volume.
- Z P takes the shape of the container.

- (1) Z only
 - (2) X and Y only
 - (3) W and Z only
 - (4) W, X and Y only
8. Joan made a comparison of the reproductive systems in flowering plants and humans in the table below.

A	Flowering Plants	Humans
B	The male sex cells are called anthers.	The male sex cells are called sperms.
C	The egg is produced in the ovary.	The egg cell is found inside the ovule.
D	Only fertilised egg cell develops into a fruit.	Only fertilised egg develops into a baby.
E	Reproduction occurs to ensure the extinction of the species.	Reproduction occurs to ensure the continuity of the species.

Which of the following is/are the correct comparison(s)?

- (1) C only
- (2) A and D only
- (3) B and C only
- (4) A, B and D only

9. Aaron set up an experiment to investigate the flexibility of 3 different materials, A, B and C as shown below.

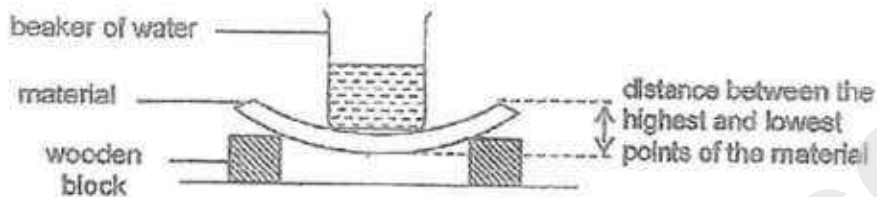

He poured different amounts of water into the beaker placed on top of each material until the distance between the highest and lowest points of the material reached 2 cm. He recorded his observations and concluded that material B was the most flexible and material A was the least flexible. Which of the following did he record in order to draw the conclusion above?

Amount of water in beaker (cm ³)			
	Material A	Material B	Material C
(1)	150	50	100
(2)	100	50	150
(3)	150	100	150
(4)	50	150	100

10. Study the water cycle below. X and Y represent the different processes that occur in the water cycle.

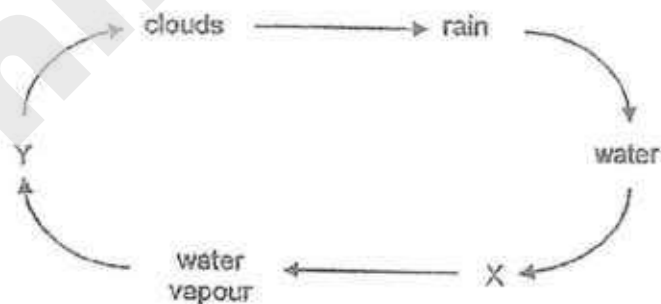

Which of the following do X and Y represent?

	X	Y
(1)	Evaporation	Melting
(2)	Condensation	Melting
(3)	Evaporation	Condensation
(4)	Melting	Evaporation

11. Mrs Lim has a discussion with her class. Four students made statements about the human reproduction process.

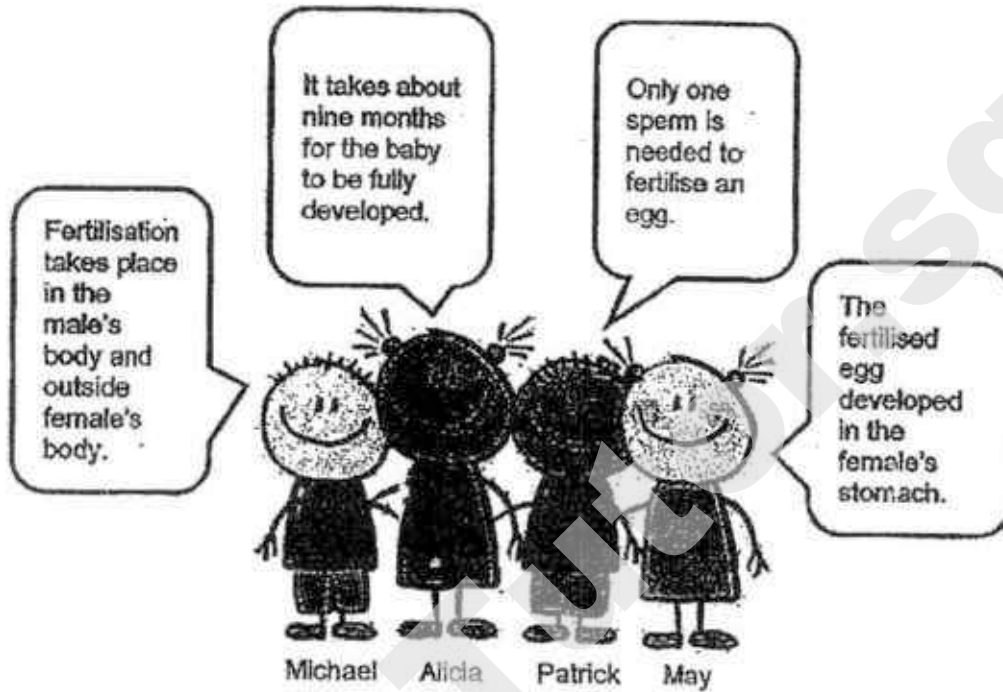

Which of the following students made correct statements about human reproduction process?

- (1) Alicia and May
- (2) May and Michael
- (3) Alicia and Patrick
- (4) Patrick and Michael

12. Rachel set up an experiment to find out how long it takes for an ice cube to melt. The graph below shows the changes in the temperature of the ice cube when it was left to melt on a plate.

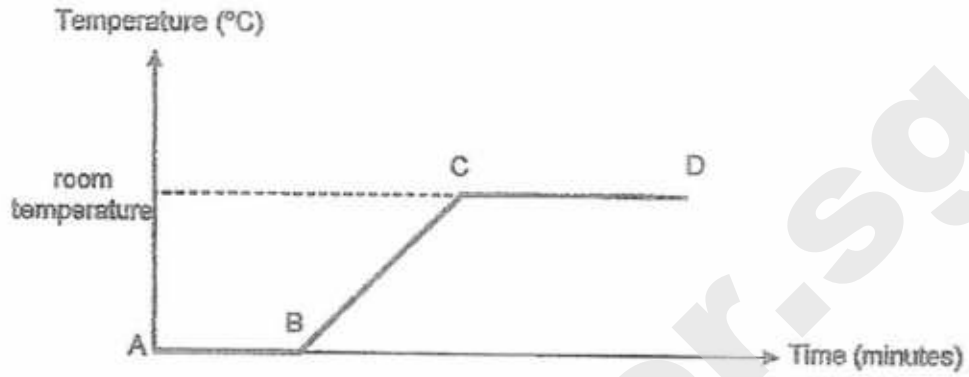

Which point of the graph shows that the ice cube has just melted completely to become water?

	Point
(1)	A
(2)	B
(3)	C
(4)	D

13. Paxon was given a glass bottle filled with oil. There was a steel ring inside.

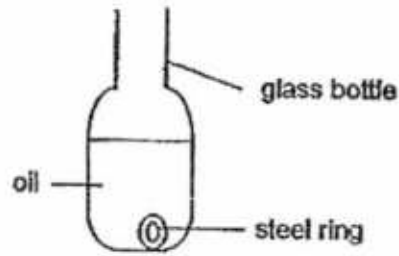

Which of the following items can he use to remove the steel ring without the item touching the oil?

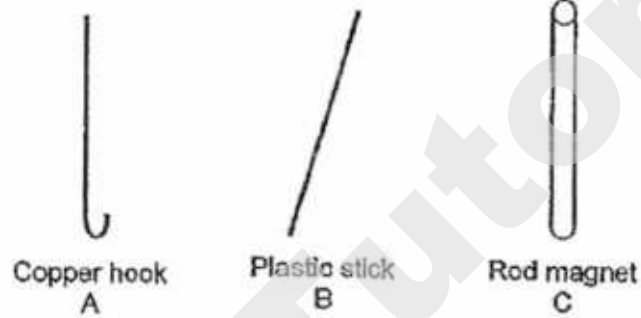

- (1) A only
(2) C only
(3) A and B only
(4) A, B and C

14. The diagram below shows the different systems in the human body working together.

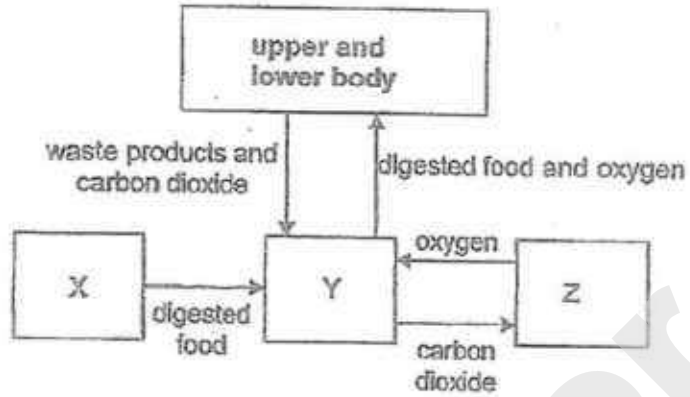

Based on the diagram above, which of the following correctly represents X, Y and Z?

	X	Y	Z
(1)	Respiratory	Circulatory	Digestive
(2)	Digestive	Respiratory	Circulatory
(3)	Circulatory	Digestive	Respiratory
(4)	Digestive	Circulatory	Respiratory

15. The diagram shows a plant and the path (→) taken by Substance X after photosynthesis.

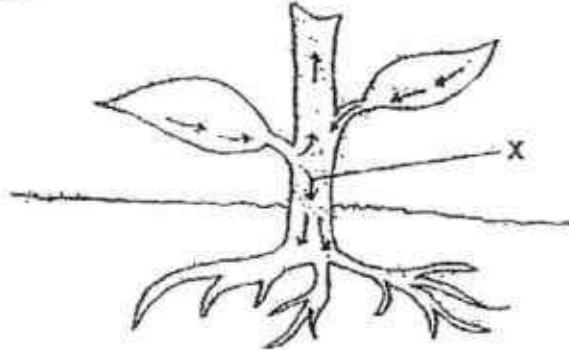

What is Substance X?

- (1) water
 - (2) glucose
 - (3) chlorophyll
 - (4) carbon dioxide
16. Denzel made the following statements on how a fish breathes.

Statement 1: Water containing dissolved oxygen enters the mouth and passes through the gills.

Statement 2: Dissolved oxygen from the water is absorbed into the blood vessels in the mouth.

Statement 3: The fish opens its mouth to release dissolved carbon dioxide in the water.

Statement 4: Dissolved carbon dioxide is carried by the blood from the different parts of the fish's body to the gills.

His teacher, Mr Karl, told him that his statement(s) is/are incorrect. Which one of the statement(s) is/are **Incorrect**?

- (1) Statement 3 only
- (2) Statement 1 and 4 only
- (3) Statement 2 and 3 only
- (4) Statement 1, 2 and 4 only

17. The bar graph below shows the concentration of oxygen in four blood samples taken at the same time from different blood vessels located at different parts of the circulatory system.

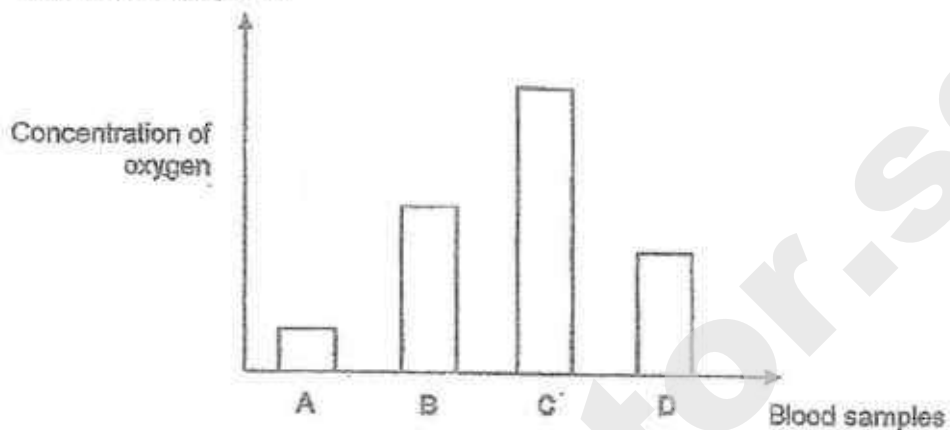

The following diagram shows how blood flows in different parts of the human body.

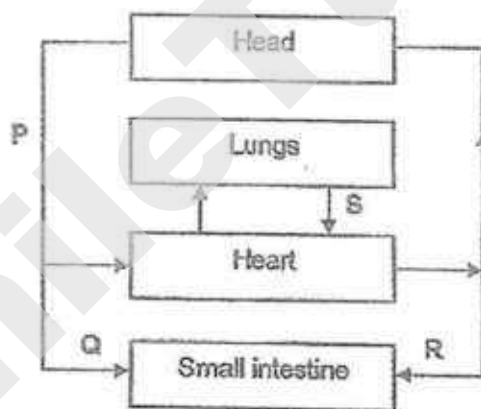

Which blood sample is most likely to be taken from the blood vessel which is labelled S in the diagram above?

- (1) A
- (2) B
- (3) C
- (4) D

18. The table below lists cell parts of animal and/or plant cells and their functions.

	Parts of Cell	Present in Animal Cell?	Present in Plant Cell?	Function of the part
A	Nucleus	Yes	Yes	Controls all activities in the cell.
B	Cytoplasm	Yes	No	Allows the movement of substances around the cell.
C	Chloroplast	No	Yes	Contains chlorophyll which captures light to make food.
D	Cell Membrane	Yes	Yes	Protects the cell and gives it a fixed shape.
E	Cell Wall	No	Yes	Controls the movement of substances in and out of the cell.

Which of the following is incorrect about the cell parts and / or their functions?

- (1) A, B and C
- (2) A, D and E
- (3) B, D and E
- (4) C, D and E

19. The diagrams below show four circuits with different arrangements of identical batteries and light bulbs.

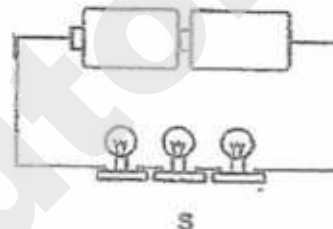
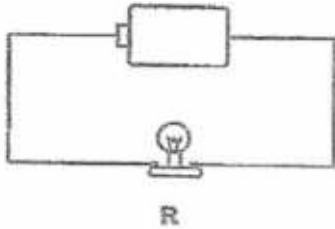
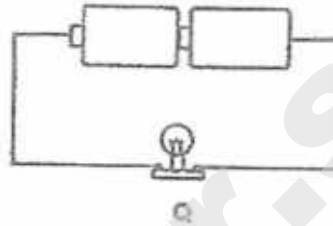
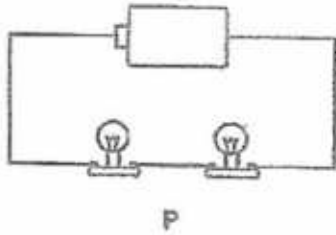

Which of the following shows the correct order of the brightness of the light bulbs in circuits P, Q, R and S, from the brightest to the dimmest?

- (1) R, Q, P, S
- (2) Q, R, S, P
- (3) Q, S, R, P
- (4) S, P, Q, R

20. Jerome used a circuit tester to test a circuit card. He connected the points X and Y of the circuit tester to the various clips K, L, M and N on a circuit card to see if the bulb would light up. He recorded the results of his experiment in the table below.

Connection tested	Did the bulb light up?
K and L	No
K and M	Yes
L and M	No
L and N	No
M and N	Yes

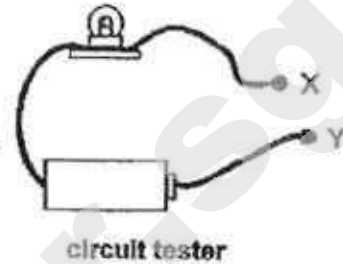

Which one of the following represents the circuit card that Jerome tested?

- (1)
- (2)
- (3)
- (4)

21. Jadyr conducted an experiment using the two set-ups as shown below. He heated both beakers with Bunsen burners of same heat intensity until the water in both beakers boiled.

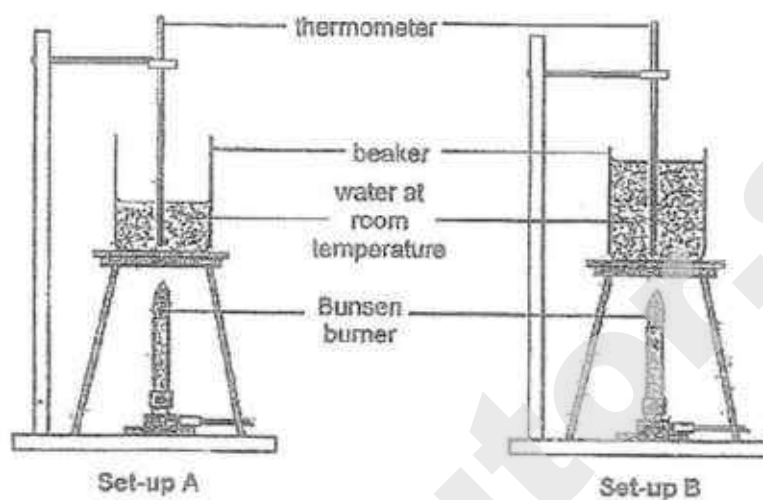

Which of the two conclusions are the most accurate based on Jadyr's experiment?

- A The water in both set-ups have the same amount of heat
 - B The water in Set-up B has more amount of heat than the water in Set-up A.
 - C The lesser the volume of water, the faster it will take to reach boiling point.
 - D The greater the volume of water, the faster it will take to reach boiling point.
- (1) A and C
 - (2) A and D
 - (3) B and C
 - (4) B and D

22. Yong Xin wanted to find out the amount of light that can pass through a material. He used a light sensor attached to a data logger and conducted an experiment with three different cups made of material, X, Y and Z, of the same size and thickness. He recorded the results in the graph below.

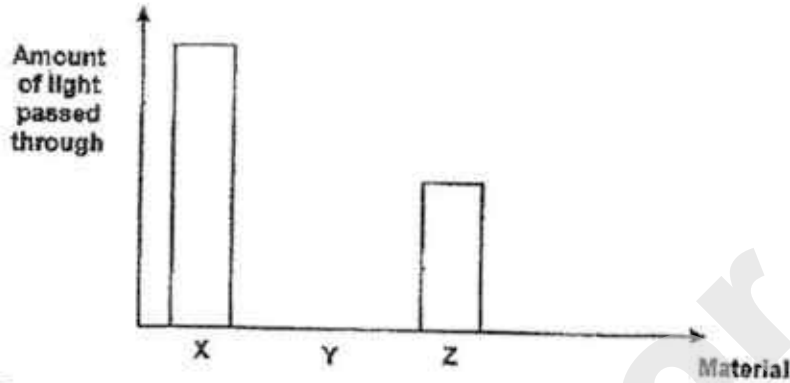

What materials could cups X, Y and Z be made of?

	X	Y	Z
(1)	frosted glass	ceramic	glass
(2)	glass	frosted glass	ceramic
(3)	frosted glass	glass	ceramic
(4)	glass	ceramic	frosted glass

23. The diagram below shows the process of photosynthesis in a plant.

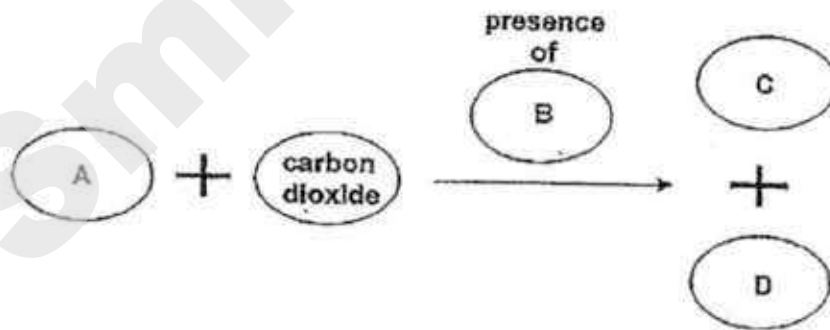

Which of the following correctly represents A, B, C and D in the diagram?

	A	B	C	D
(1)	sugar	light	water	energy
(2)	water	sugar	light	energy
(3)	light	sugar	water	oxygen
(4)	water	light	sugar	oxygen

- 24 Jonathan rolled a ball down a U-shaped ramp. The diagram below shows the position of the ball as it rolls from A to C.

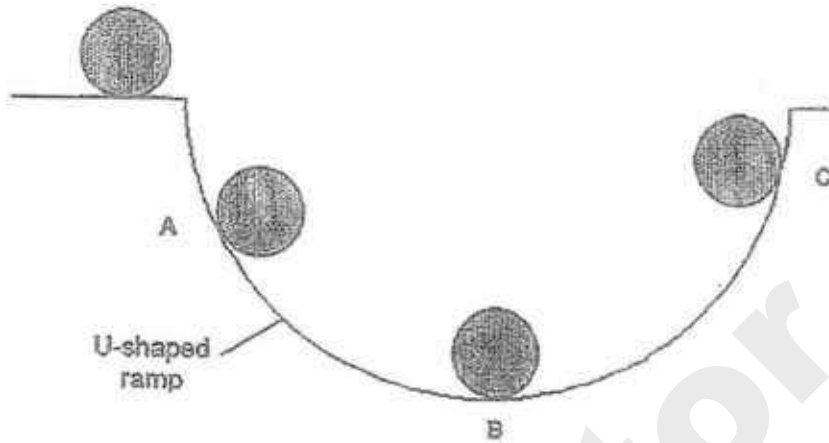

Which of the following shows correctly the changes in the kinetic energy and potential energy of the ball as it rolls from A to C?

	change in kinetic energy from A to B	change in potential energy from B to C
(1)	increases	increases
(2)	increases	decreases
(3)	decreases	increases
(4)	decreases	decreases

25. Gabriel threw a ball from point W. The diagram below shows the position of the ball at points X, Y and Z, after it was thrown.

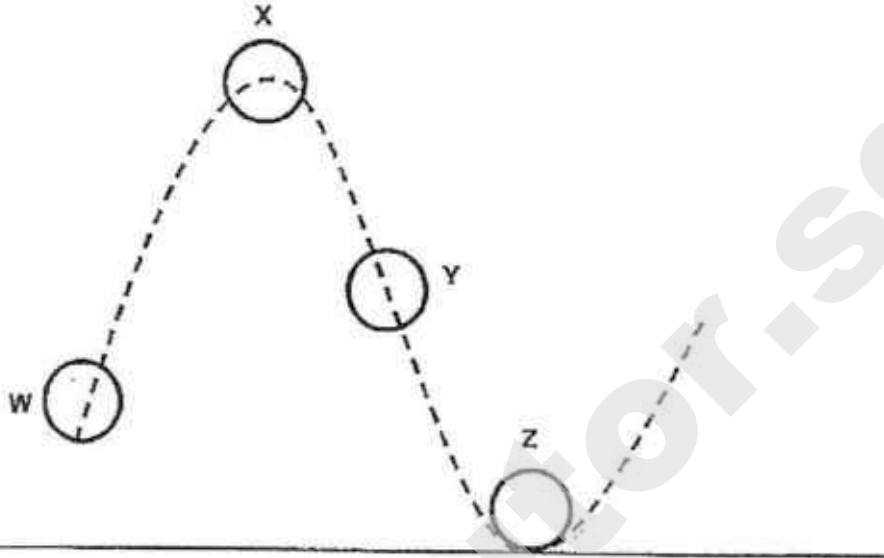

Gabriel described the energy the ball possessed when it was at points W, X, Y and Z.

Which of the following descriptions are correct?

- A There is no potential energy at Point W.
- B The kinetic energy at Point Y is higher than the kinetic energy at Point Z.
- C The potential energy at Point X is higher than the potential energy at Point Z.
- D The kinetic energy is decreasing as the ball travels from Point W to Point X.

- (1) A and B only
- (2) C and D only
- (3) A, C and D only
- (4) B, C and D only

End of Booklet A

SEMESTRAL ASSESSMENT 2 (2017)
PRIMARY 5
SCIENCE
BOOKLET B

THURSDAY

2 November 2017

1 HOUR 30 MINUTES

Name : _____ ()

Class : P5 _____

INSTRUCTIONS TO PUPILS

DO NOT TURN OVER THE PAGES UNTIL YOU ARE TOLD TO DO SO

Follow all instructions carefully.

There are 13 questions in this booklet.

Answer **ALL** questions.

INFORMATION FOR PUPILS

The number of marks is given in brackets [] at the end of each question or part question.

The total marks for this booklet is 40.

The total time for Booklets A and B is 1 hour 30 minutes.

This question paper consists of 14 printed pages (inclusive of cover page).

BOOKLET A	/ 50
BOOKLET B	/ 40
PBA	/ 10
TOTAL	/ 100
Parent's signature/ Date:	

Booklet B (40 marks)

For questions 26 to 38, write your answers in this booklet.

The number of marks available is shown in brackets [] at the end of each question or part question.

26. • The diagrams represent the life cycles of a mealworm beetle and a cockroach.

(a) Fill in the boxes with the following words. (You may repeat some of the words.) [2]

- Egg
- Adult
- Pupa
- Larva
- Nymph

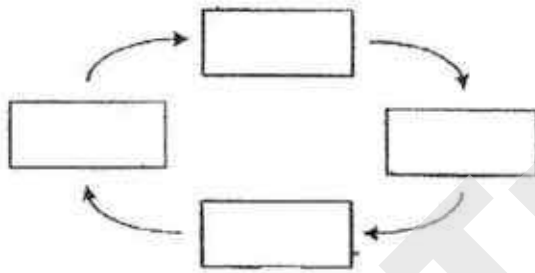

Life cycle of a mealworm beetle

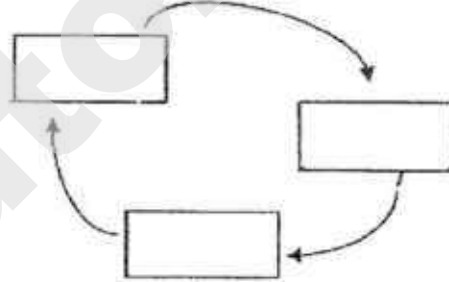

Life cycle of a cockroach

(b) State a similarity between the young and the adult of the cockroach. [1]

(c) At which stage of the life cycle of the mealworm beetle does it moult? Why does it moult at that stage? [1]

(Go on to the next page)

SCORE	4
-------	---

27. Jermaine planted a bean seed in a transparent pot. Over the next month, she observed its growth and drew her observations. The diagrams show her drawings.

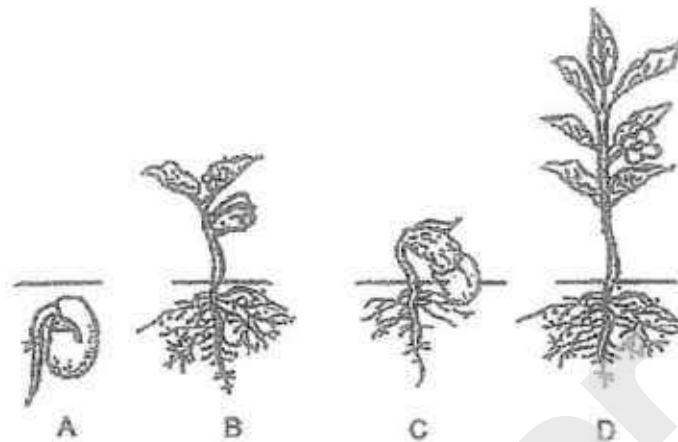

- (a) Arrange Jermaine's drawings of her observations, A, B, C and D, in the correct order beginning with what she saw first. [1]

- (b) What are the conditions necessary for germination to take place? [1]

- (c) In the box below, label and name the part that provides the energy for germination. [1]

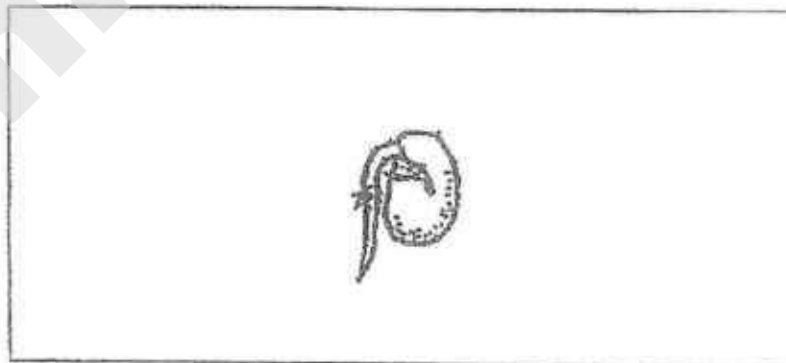

(Go on to the next page)

SCORE	
	3

28. Study the diagram below carefully. The diagram represents some of the characteristics of Laura's family.

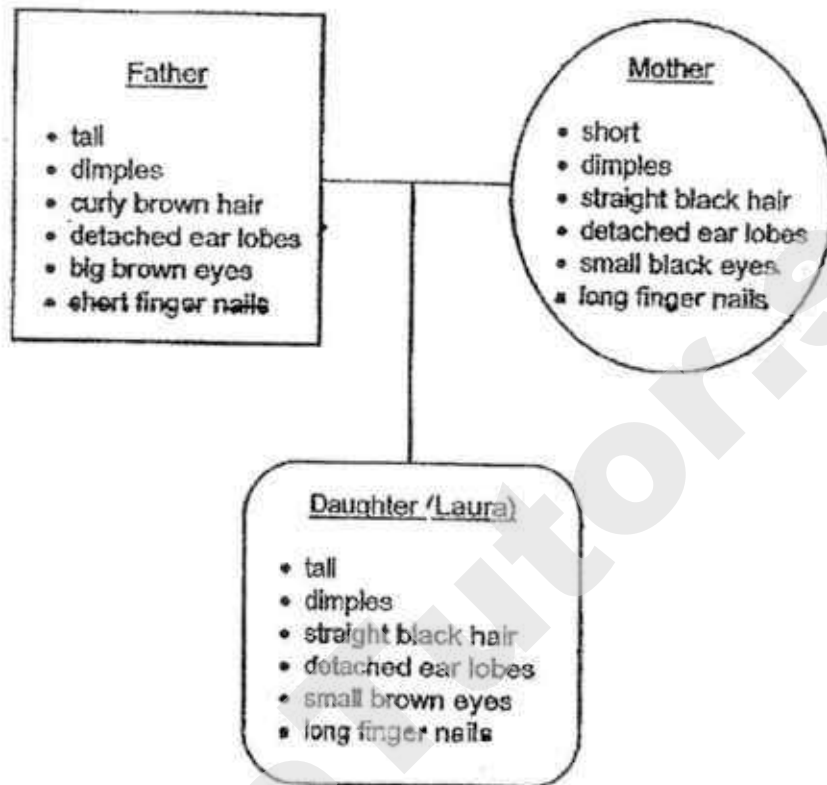

- (a) Which characteristics that are common to both parents did Laura inherit? [1]

- (b) Name one characteristic found only in Laura's mother that Laura inherited. [1]

(Go on to the next page)

SCORE	2
-------	---

29. Gideon conducted an experiment as shown in the diagram below. He heated some water in Petri dish X until it started boiling. He then placed a metal tray above it.

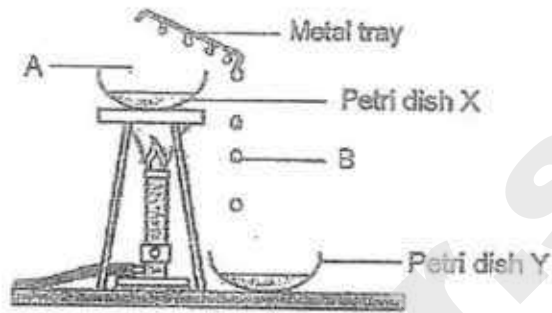

- (a) Identify the states of water at A and B. [1]

A: _____

B: _____

- (b) At the end of the experiment, Gideon noticed that the volume of water in the Petri dish X had decreased. Explain why. [1]

- (c) Explain clearly how the water droplets on the metal tray were formed. [2]

- (d) Suggest and explain clearly how he can collect more water in Petri dish Y for the same duration of the experiment. [1]

(Go on to the next page)

SCORE	/
	5

30. Ashley prepared the following 3 set-ups, X, Y and Z, and placed them in the laundry room. There were 3 identical towels weighing 150g each at the start of the experiment. Each towel was then soaked in 100 ml of water.

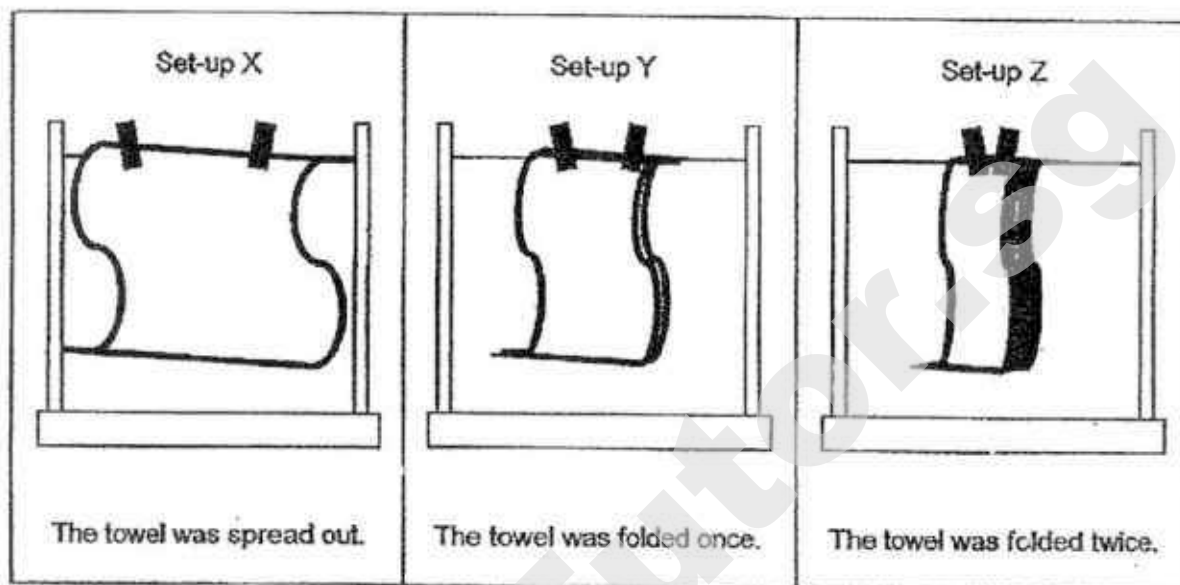

The table below shows the mass of each towel after 8 hours.

Mass of towel after 8 hours (g)		
X	Y	Z
150	190	210

- (a) Based on the information given in the table above, in which set-up was the rate of evaporation the fastest? [1]
- _____
- (b) What was the factor that affected the rate of evaporation in this experiment? [1]
- _____
- (c) From the result of the experiment, which data in the above table is Incorrect? Why? [1]
- _____
- _____

(Go on to the next page)

SCORE	
	3

31. Peter hung 4 objects from a rod as shown in the diagram below.

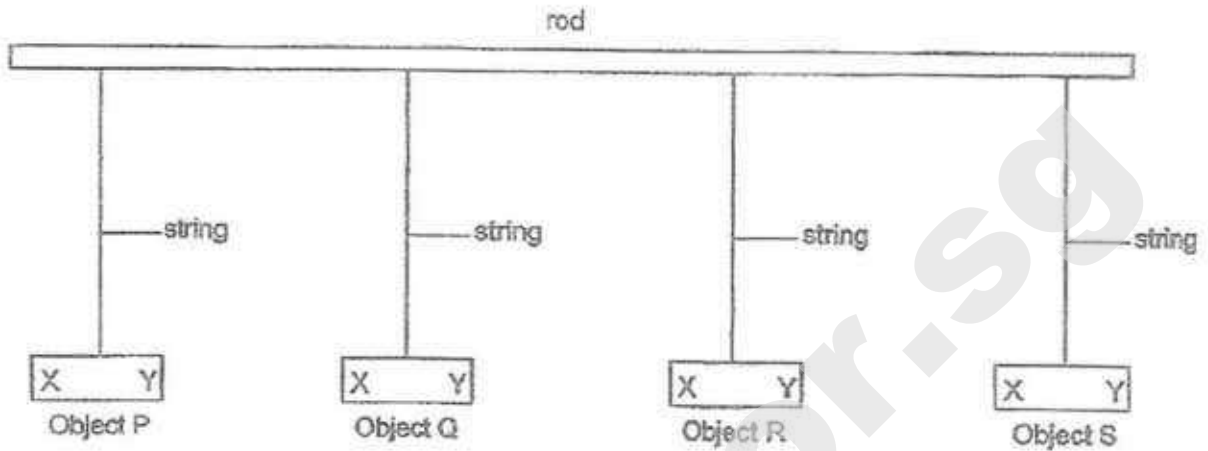

He placed the North Pole of a bar magnet near the four objects and recorded his observations in the table below.

Object	Observations	
	North Pole and X	North Pole and Y
P	attracted	repelled
Q	attracted	attracted
R	remained still	remained still
S	repelled	attracted

- (a) Which object, P, Q, R or S, could be made of glass? Explain why. [1]

- (b) What material could Object Q be made of? Explain your answer based on the observations made by Peter. [1]

- (c) Which of the object(s) is/are magnets? Explain why. [1]

(Go on to the next page)

SCORE	3

32. The diagram below shows the human digestive system.

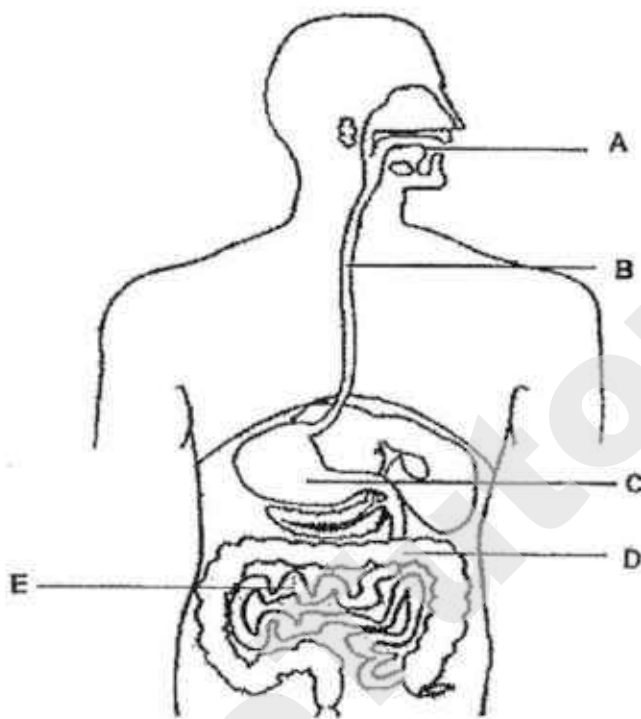

(a) Name the parts labelled B and E. [1]

B: _____

E: _____

(b) A substance is added to food in both parts A and C. What is this substance? [1]
Explain its function.

(c) What is the function of Part D? [1]

(Go on to the next page)

SCORE	/
	3

33. Kelvin was lifting some weights in the gym.



- (a) Describe how oxygen in the surrounding air was sent to his arms when he was lifting the weights. [2]

- (b) State two substances in the circulatory system that the body requires more when he was lifting weights. [1]

(Go on to the next page)

SCORE	
	3

34. Jeff made a study of the parts that are found in some cells. He recorded his observations in the table below, using a tick (✓) to indicate the presence of the parts in each cell.

	Cell A	Cell B	Cell C
Cell wall	✓		✓
Cell membrane	✓	✓	✓
Chloroplast	✓		
Cytoplasm	✓	✓	✓
Nucleus	✓	✓	✓

- (a) Which of the cell(s) is / are likely to be taken from a plant? Give a reason for your answer. [1]

Study the diagram.

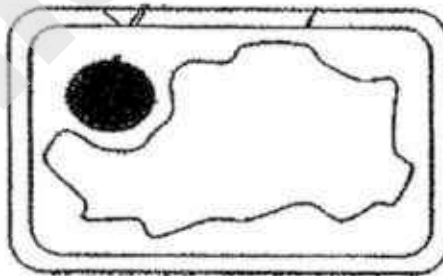

- (b) Which cell, A, B or C, best represents the diagram above? [1]

- (c) In the diagram above, label and name the part that control the movement of substances going in and out of the cell. [1]

(Go on to the next page)

SCORE	
	3

35. The diagram below shows a bulb and two batteries.

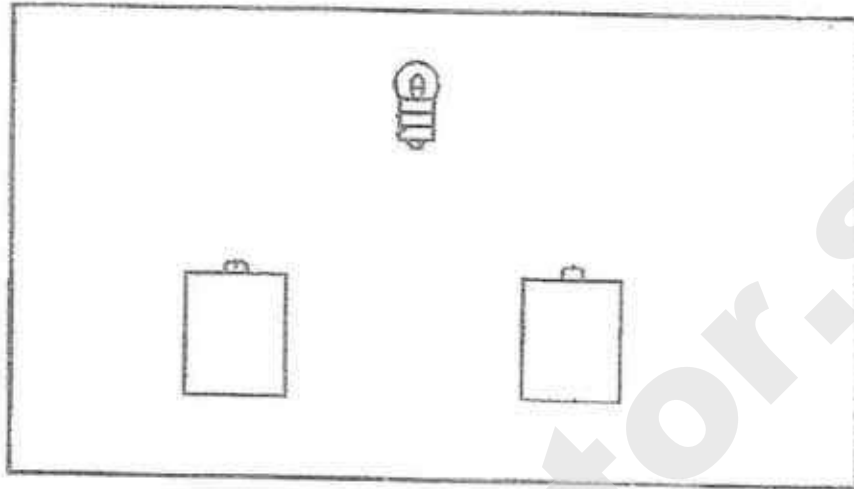

- (a) Draw 3 wires to show how you would connect the batteries to the bulb to produce the brightest light. [1]
- (b) Study the electrical circuit below.

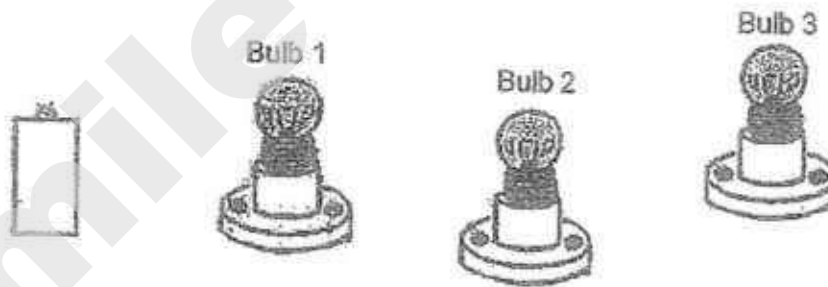

- (i) What will happen to the other bulbs if Bulb 2 is blown? [1]

- (ii) What can he do to allow him to control the light bulbs individually? [1]

(Go on to the next page)

SCORE	
	3

36. Christopher filled two identical containers, A and B, made of the same material with equal amounts of water at different temperatures. He then placed them in a room with a temperature of about 28°C.

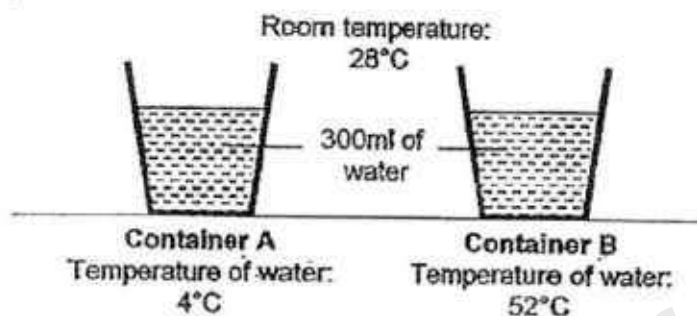

- (a) The set-up was left in the room for about 30 minutes. Place a tick (✓) in the correct boxes to indicate the possible changes taking place during the 30 minutes. [1]

	Lose heat	Gain heat	Temperature increases	Temperature decreases
Water in Container A				
Water in Container B				

Christopher then set up another similar experiment but the containers (C and D) were made of different materials. He filled them up with water.



- (b) What was the aim of Christopher's second experiment? [1]

- (c) In the table below, put a tick (✓) in the boxes next to the statements for the experiment to be a fair test. [1]

Statements	Tick (✓)
Both containers should have the same amount of water.	
Both containers must be of the same size.	
Both containers must be made of the same material.	
The temperature of the water in both containers must be different.	
Both must be placed in the same location.	

(Go on to the next page)

SCORE	3
-------	---

37. Andrew released three identical steel balls, X, Y and Z from three different heights onto a tray of sand. The diagram below shows the depressions made by the three iron balls after they were released.

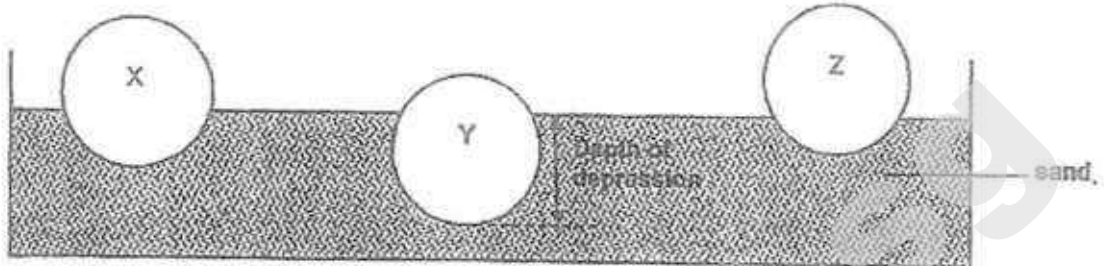

- (a) Based on the diagram above, arrange the steel balls, X, Y and Z, based on the height they were released from the highest to the lowest. [1]

Andrew bought a styrofoam ball, C, of the same size as the steel balls. He dropped balls C and Y from the same height.

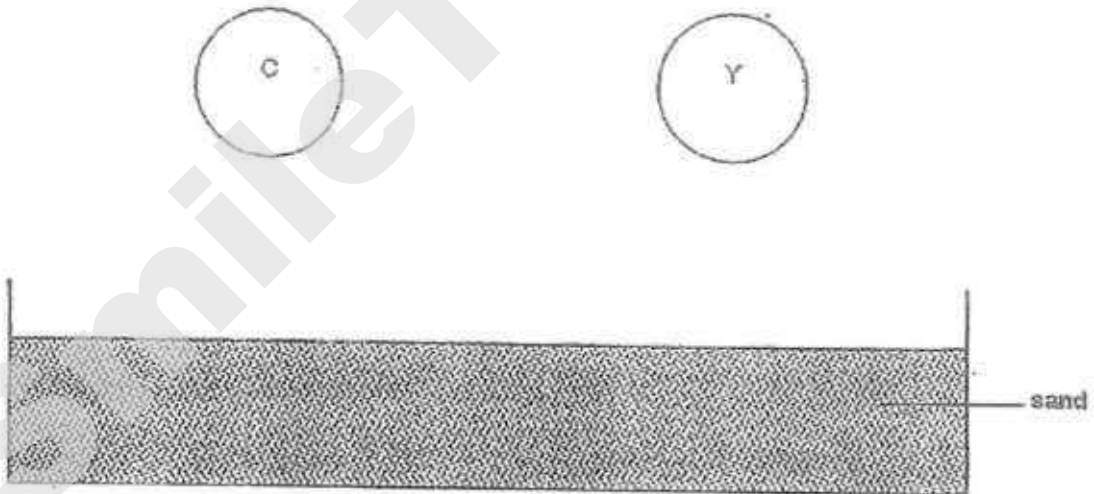

- (b) What would Andrew observe? Explain your answer. [1]

(Go on to the next page)

SCORE	
	2

38. Dominic set up an experiment using a water source and a water wheel as shown in the diagram below.

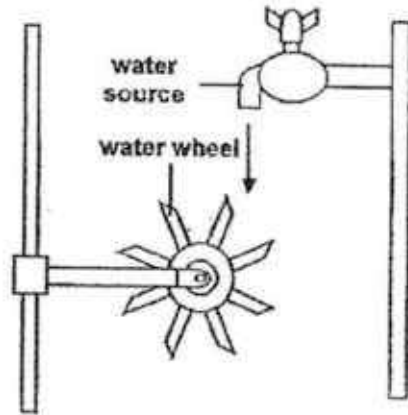

- (a) Without adding or replacing any of the items above, state two methods for Dominic to increase the speed at which the water wheel turns. [2]

Method 1:

Method 2:

- (b) Name the main form of energy the spinning water wheel has as it turns. [1]

End of Paper

SCORE	3
-------	---

EXAM PAPER 2017 (P5)

SCHOOL : ACS

SUBJECT : SCIENCE

TERM : SA2

Q1	Q2	Q3	Q4	Q5	Q6	Q7	Q8	Q9	Q10
2	4	2	1	3	2	3	1	1	3
Q11	Q12	Q13	Q14	Q15	Q16	Q17	Q18	Q19	Q20
3	2	2	4	2	3	3	3	2	4
Q21	Q22	Q23	Q24	Q25					
3	4	4	1	2					

26)a)

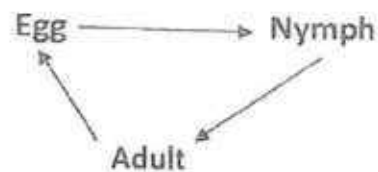
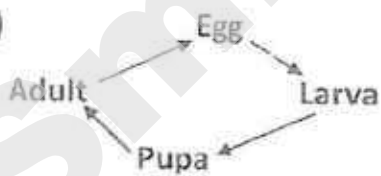

b) They resemble each other.

c) Larva. The larva is growing bigger.

27)a) A, C, B, D

b) Air, Water, Warmth

c)  seed leaf

28)a) Dimples and detached ear lobes.

b) Straight black hair.

29)a) A: Gas B: Liquid

b) The water had gained heat from the fire and had evaporated into water vapour.

c) When the water vapour touches the cooler underside of the metal tray the water vapour loses heat and condenses into water droplets.

d) Add ice into petri dish X, the lower the temperature of water in petri dish X the faster the rate of condensation.

30)a) X.

b) The amount of exposed surface area.

c) The mass of towel in set-up Z after 8 hours is incorrect. The mass of the towel after 8 hours cannot be the same as the mass of the towel at the beginning of the towel after 8 hours must be less than that at the beginning of the experiment.

31)a) R. As glass is a non-magnetic material, it will not respond to any magnet like shown in the table.

b) Steel. It did not get repelled by the magnet but got attracted, steel is a magnetic material and it will only get attracted.

c) P and S. Only magnets can repel each other when their like poles are facing each other.

32)a) B: Gullet E: Small intestine

b) Digestive juices. It breaks down food into simpler substances faster.

c) It is to absorb all the water from the undigested food.

33)a) When the weight lifts he will breathe in the air from the surroundings the air will be sent to the lungs, the lungs will then be absorbed, it will then be sent to the heart the heart will pump the oxygenated blood to the arms.

b) Oxygen and water.

34)a) A and C. Only plants cell wall other one does not have cell wall.

b) C.

c)

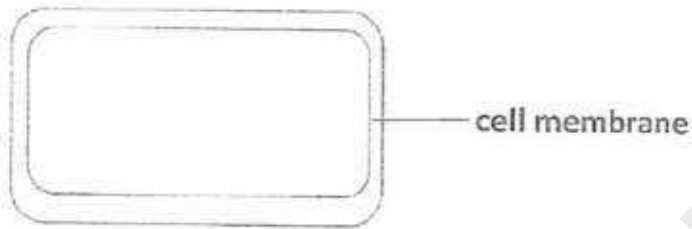

35)a)

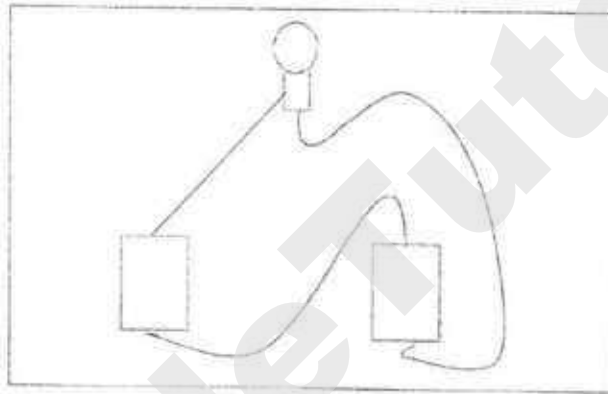

i) Nothing will happen, bulb 2 and 3 will still be lit up.

ii) He can fix a switch beside every bulb.

36)a)

	Lost heat	Gain heat	Temperature increases	Temperature decreases
Water in A		✓	✓	
Water in B	✓			✓

b) To find out which material is a better conductor of heat.

36)c)

✓
✓
✓

37)a) Y, X, Z

b) Ball Y made a deeper depression than ball C, hence more potential energy is converted into kinetic energy.

38)a) 1) Turn the water source more so that more water could flow out.

2) Place the water source higher.

b) Kinetic energy.