



聖嬰中學
HOLY INNOCENTS' HIGH SCHOOL

MID-YEAR EXAMINATION 2014
SECONDARY 1 EXPRESS

MATHEMATICS

4016/01

Paper 1

Name : _____

Date : 16 May 2014

Register No : _____

Duration : 1 h 30 min

Class : _____

Marks : /60

Additional Materials needed: NIL

Students answer on the Question Paper.

Instructions to Candidates

Write your index number and name on all the work you hand in.

Write in dark blue or black pen.

You may use a pencil for any diagrams or graphs.

Do not use staples, paper clips, highlighters, glue or correction fluid.

Answer **all** questions.

If working is needed for any question, it must be shown with the answer.

Omission of essential working will result in loss of marks.

Calculators should be used where appropriate.

If the degree of accuracy is not specified in the question, and if the answer is not exact, give the answer to three significant figures. Give answers in degrees to one decimal place.

For π , use either your calculator value or 3.142, unless the question requires the answer in terms of π .

The number of marks is given in brackets [] at the end of each question or part question.

The total marks for this paper is 60.

Setter: Mr Jarrod Tan

81

This paper consists of 11 printed pages, inclusive of this cover page.

Answer all the questions.

- 1 (a) 25% of a number is 30. Find the number.
- (b) Mina bought 250 bulbs. 8% of the bulbs are spoilt after less than 10 hours of use. Find the number of bulbs that lasted for at least 10 hours.

Answer (a) [1]

(b)bulbs [1]

2 Evaluate $\frac{20\pi - 26.8}{\sqrt{22.57 \div 0.03}}$.

Answer [2]

3 Express

- (a) 0.0376 correct to the nearest hundredth,
- (b) -127.792 correct to the nearest integer.

Answer (a) [1]

(b) [1]

- 4 "343 is a prime number".
State whether this statement is true or false. Give reasons for your answer.

Answer:
..... [2]

- 5 Arrange the following numbers in ascending order.

$$-(1.346)^2, -1.\ddot{8}1, -1.8\dot{1}, -\sqrt{\frac{43}{13}}, -\frac{181}{1000}$$

Answer [2]

- 6 Mrs Lim has 2 daughters, Helen and Melissa.
The highest common factor and lowest common multiple of their ages are 3 and 168 respectively. If Helen is 3 years older than her sister, find Helen's age.

83

Answer years old [2]

- 7 The freezing point of a liquid is -7°C .
The temperature difference between its freezing point and boiling point is 25°C .
- (a) Find the boiling point of the liquid.
 - (b) An addition of a small quantity of salt into the liquid decreased its freezing point by 0.8°C and increased its boiling point by 0.7°C .

Find the temperature difference between the freezing point and the boiling point of this liquid-salt mixture.

Answer (a) $^{\circ}\text{C}$ [1]

(b) $^{\circ}\text{C}$ [2]

- 8 Given the list of numbers

$$\sqrt[3]{6}, 0, \sqrt{121}, \pi, 2.\dot{1}, \frac{151}{-3}, 1, -\sqrt{25},$$

write down

- (a) the integer(s),
- (b) the irrational number(s),
- (c) the prime number(s).

Answer (a) [1]

(b) [1]

(c) [1]

- 9 Ferries to Port A and Port B depart from the same ferry terminal.
Ferry to Port B departs every 26 minutes while the ferry to Port A departs every 18 minutes.
If both ferries depart at 1324 hrs, state the next time that both ferries will depart from the same ferry terminal again.

Answer..... [3]

- 10 (a) Express 7056 as a product of its prime factors.
(b) Hence find the positive square root of 7056, leaving your answer in index notation.

Answer (a) 7056 = [2]

(b) [1]

11 (a) Solve $\frac{m}{2} + 3m \geq \frac{2}{5}$.

- (b) Hence write down the smallest integer value of m that satisfies $\frac{m}{2} + 3m \geq \frac{2}{5}$.

Answer (a) 85 [2]

(b) [1]

12 Solve

(a) $\frac{x+1}{3} = 15,$

(b) $5y + 12 = 18 - 3(y - 2).$

Answer (a) $x = \dots\dots\dots$ [1](b) $y = \dots\dots\dots$ [2]13 Given that $2 \leq x < 6$ and $-5 \leq y \leq -2$, and x and y are integers, find(a) the least possible value of $y - x$,(b) the least possible value of $\frac{x}{y}$,(c) the greatest possible value of $x^2 y^2$.Answer (a) $\dots\dots\dots$ [1](b) $\dots\dots\dots$ [1](c) $\dots\dots\dots$ [1]

14 (a) In the diagram, BD is a straight line.

Find the value of

- (i) x ,
- (ii) y .

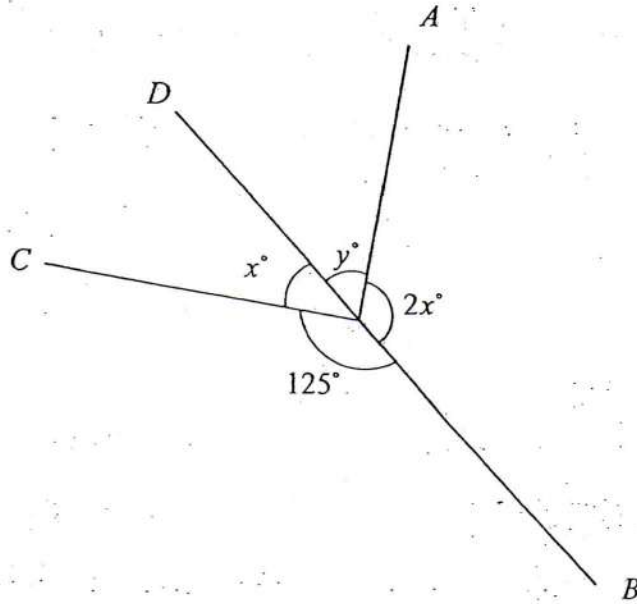

(b) Using a protractor, measure $\angle XYZ$.

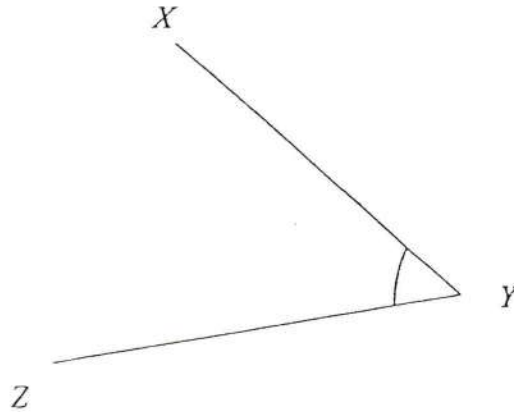

Answer (a)(i) $x = \dots\dots\dots$ [1]

(ii) $y = \dots\dots\dots$ [2]

87 (b) $\angle XYZ = \dots\dots\dots^\circ$ [1]

- 15 The figure shows an open fish tank measuring 45 cm by 16 cm by 21 cm.
The tank is $\frac{6}{7}$ filled with water.

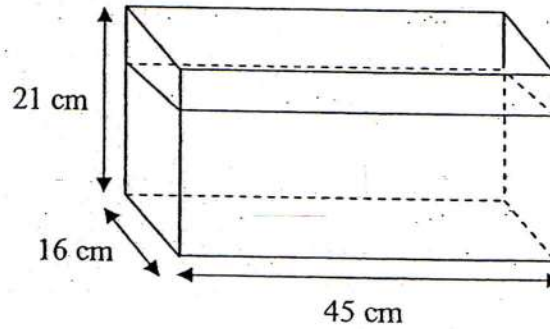

- (a) Find
- the height of water in the tank,
 - the volume of the water in the tank.
- (b) An additional amount of water is then poured into the tank.
- Calculate the volume of water that is required to fill the tank completely.
 - Water in the tank is now poured into glasses with a capacity of 600 ml each. Calculate the number of glasses that can be completely filled with water.

Answer (a)(i) cm [1]

(ii) cm^3 [1]

(b)(i) cm^3 [1]

(ii) glasses [2]

- 16 (a) Given a polynomial $5x - 12 + 3x^2$, state
- (i) the coefficient of x^2 ,
 - (ii) the constant term .
- (b) What polynomial must be added to $-p + 8q - 11$ to give $p + 6q - 3$?
- (c) Express the following statements algebraically, leaving your answer in its simplest form.
- (i) Add the square of a to the quotient of $51a^3$ divided by $3a$,
 - (ii) Subtract the square of w from the cube root of y .

Answer (a) (i) [1]

(ii) [1]

(b) [2]

(c) (i) [1]

87 (ii) [1]

17 (a) Simplify $4ab^2 - a(-3a)^2$.

(b) Given that $\frac{6x+4y}{-2y+4x} = \frac{4}{3}$, find the value of $\frac{y}{x}$.

(c) It is given that $h^2 = 3m - ef$.

Find the value of m when $e = -7$, $f = 3$ and $h = -3$.

Answer (a) [1]

(b) $\frac{y}{x} =$ [3]

(c) $m =$ [2]

- 18 (a)(i) $ABCD$ is a square.
 $AB = 36$ cm.
 A point M is on the side BC where $BM : MC = 5 : 4$.
 Find the length of BM .

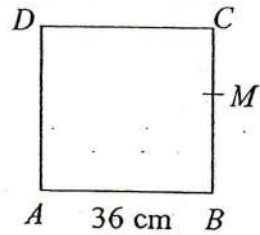

- (ii) Given that AM is 14% longer than AB , find the length of AM .
 Give your answer correct to the nearest whole number.
- (b)(i) Triangle A has a base length of 14 cm and a perpendicular height of H cm.
 Express the area of Triangle A in terms of H .
- (ii) Triangle B has a base length three times that of Triangle A and its perpendicular height twice that of Triangle A .
 Find the ratio of the area of the Triangle B to Triangle A .

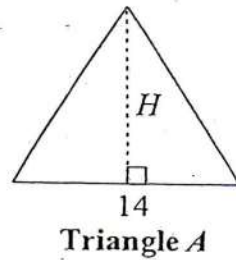

Answer(a)(i)..... cm [2]

(ii)..... cm [1]

(b)(i) cm² [1]

(ii) [2]

- End of paper -

Marking Scheme for 2014 Sec 1 Express Maths MYE P1

Qn	Answers	Marks	Remarks
1a	$30 \div 25\% = 120$	B1	
b	$92\% \times 250 = 230$	B1	
2	$1.313655 \approx 1.31$ (3.s.f)	B2	Must approx. to 3 s.f.
3a	$0.0376 \approx 0.04$ (nearest hundredth)	B1	
b	-128 (nearest integer)	B1	
4	No. 343 can be divided by more than 2 factors (e.g. 7 and 49)	B2	No marks awarded for any answer without reasons
5	$-\sqrt{\frac{43}{13}}, -1.8\dot{1}, -(1.346)^2, -1.8\dot{1}, -\frac{181}{1000}$	B2	1 mark for 3 consecutive answers
6	HCF = 3 LCM (168) = $2^3 \times 7 \times 3$ Their ages are $2^3 \times 3$ and 7×3 i.e. 24 and 21 \therefore Helen's age is 24.	M1 A1	Marks awarded for LCM of 168 Marks awarded for obtaining their ages using HCF and LCM
7a	18°C	B1	
b	$18.7^\circ\text{C} - (-7.8^\circ\text{C}) = 26.5^\circ\text{C}$	B2	1 mark for correct new boiling and freezing points.
8a	$0, 1, \sqrt{121}, -\sqrt{25}$	B1	
b	$\sqrt[3]{6}, \pi$	B1	
c	$\sqrt{121}$	B1	
9	$26 = 2 \times 13$ $18 = 2 \times 3^2$ LCM = $2 \times 3^2 \times 13$ = 234 mins 234 mins equivalent to 3h 54 min Required time will be at 17 18hrs or 5.18pm	M1 M1 A1	
10a	$7056 = 2^4 \times 3^2 \times 7^2$	B2	Marks awarded for factor tree method
b	$7056 = (2^2 \times 3 \times 7)^2$ $\therefore \sqrt{7056} = \sqrt{(2^2 \times 3 \times 7)^2}$ = $2^2 \times 3 \times 7$	B1	Must show working for mark to be awarded

11a	$\frac{m}{2} + 3m \geq \frac{2}{5}$ $\left(\frac{m}{2} \times 10\right) + (3m \times 10) \geq \frac{2}{5} \times 10$ $5m + 30m \geq 4$ $m \geq \frac{4}{35}$	M1 A1	Also accept $m \geq 0.114$ (3 s.f.)
11b	Smallest integer value is 1	B1	(Note: $\frac{4}{35} = 0.1142857\dots$)
12a	$\frac{x+1}{3} = 15$ $x+1 = 45$ $x = 44$	B1	
b	$5y + 12 = 18 - 3(y - 2)$ $5y + 12 = 18 - 3y + 6$ $8y = 24 - 12$ $y = \frac{12}{8}$ $y = 1\frac{1}{2} \quad \text{or} \quad y = 1.5$	M1 A1	1 mark awarded for correct expansion
13a	$x: 2, 3, 4, 5$ $y: -5, -4, -3, -2$ Least value $y - x = -5 - 5$ $= -10$	B1	
b	Least value $\frac{x}{y} = \frac{5}{-2}$ $= -2.5$	B1	
c	Greatest value $x^2 y^2 = 5^2 (-5)^2$ $= 625$	B1	
14ai	$x + 125^\circ = 180^\circ$ (adj. \angle on a st. line) $x = 55^\circ$	B1	
aii	$y + 2(55) = 180^\circ$ $y = 70^\circ$	M1 A1	
b	$\angle XYZ = 50^\circ (\pm 1^\circ)$	B1	
15ai	Height of water $= \frac{6}{7} \times 21$ $= 18 \text{ cm}$	B1	

aii	Vol. of water in tank = $45 \times 16 \times 18$ = 12960 cm^3	B1	
15bi	Vol. of water required to fill the tank = $45 \times 16 \times 3$ = 2160 cm^3	B1	
bii	No. of cups = $(12960 + 2160) \div 600$ = 25.2 ≈ 25	M1 A1	
16ai	Coefficient of x^2 is 3	B1	
aii	Constant term is -12	B1	
b	$(p + 6q - 3) - (-p + 8q - 11)$ = $2p - 2q + 8$	M1 A1	Award 1 mark for correct order of subtraction of polynomials
ci	$\frac{51a^3}{3a} + a^2 = 18a^2$	B1	
cii	$\sqrt[3]{y} - w^2$	B1	
17a	$4ab^2 - a(3a)^2$ = $4ab^2 - 9a^3$	B1	
b	$\frac{6x + 4y}{-2y + 4x} = \frac{4}{3}$ $18x + 12y = -8y + 16x$ $20y = -2x$ $\frac{y}{x} = -\frac{2}{10}$ $\therefore \frac{y}{x} = -\frac{1}{10}$	M2 A1	1 mark for correct expansion for each expression
c	$h^2 = 3m - ef$ $(-3)^2 = 3m - (-7)(3)$ $9 = 3m + 21$ $3m = -12$ $m = -4$	M1 A1	
18ai	9 units rep 36 cm 1 unit rep 4 cm 5 units rep 20 cm $\therefore BM = 20 \text{ cm}$	M1 A1	
aii	$AM = 114\% \times 36$ = 41.04 $\approx 41 \text{ cm. (nearest whole no.)}$	B1	105

18bi	$\text{Area of triangle} = \frac{1}{2} \times 14 \times H$ $= 7H \text{ cm}^2$	B1	
bii	$\text{New area} = \frac{1}{2} \times (14 \times 3) \times (H \times 2)$ $= 42H \text{ cm}^2$ <p>Ratio of new area : Original area</p> $42H : 7H$ $6 : 1$	M1 A1	Award mark for area of triangle B
	Total marks	60	



聖嬰中學
HOLY INNOCENTS' HIGH SCHOOL

MID-YEAR EXAMINATION 2014
SECONDARY 1 EXPRESS

MATHEMATICS

4016/02

Paper 2

Name : _____

Date : 14 May 2014

Register No : _____

Duration : 1 h 30 min

Class : _____

Additional Materials: 4 sheets of Writing Paper

INSTRUCTIONS TO STUDENTS

Write your index number and name on all the work you hand in.
Write in dark blue or black pen.
You may use a pencil for any diagrams or graphs.
Do not use staples, paper clips, highlighters, glue or correction fluid.

Answer all questions.

If working is needed for any question, it must be shown with the answer.
Omission of essential working will result in loss of marks.
Calculators should be used where appropriate.
If the degree of accuracy is not specified in the question, and if the answer is not exact, give the answer to three significant figures. Give answers in degrees to one decimal place.
For π , use either your calculator value or 3.142, unless the question requires the answer in terms of π .

The number of marks is given in brackets [] at the end of each question or part question.
The total marks for this paper is 60.

Setter: Ms Nicole Goh

This paper consists of 8 printed pages, inclusive of this cover page.

Answer all the questions

- 1 Adam, Benjamin and Charlie worked at the same supermarket.
Each of them was paid \$4 per hour.
Adam worked for x number of hours.
Benjamin worked for 3 hours more than Adam.
Charlie worked twice as long as Benjamin.
- (a) Write down an expression, in terms of x , for
- (i) the number of hours for which Benjamin worked, [1]
 - (ii) the number of hours for which Charlie worked. [1]
- (b) Write down and simplify the expression, in terms of x , for the total number of hours Adam, Benjamin and Charlie spent on work. [2]
- (c) Given that a total of \$169 was paid to Adam, Benjamin and Charlie, form an equation in x , and solve the equation to find the number of hours that Benjamin had worked. [2]
- 2 (a) Mr Tan's weekly salary \$ A , is made up of a basic salary of \$50 and \$3.50 for every delivery he makes.
- (i) In a particular week, he made a total of 75 deliveries.
Calculate the salary he earned in that week. [1]
 - (ii) At the end of another week, he received \$372.
How many deliveries did he make? [2]
 - (iii) If he makes n deliveries in a week, write down the formula for A in terms of n . [1]
- (b) Mr Lim is given a basic salary of \$600 for the first 100 deliveries and \$1.50 for every subsequent delivery he makes.
Calculate who will earn more if each of them makes a total of 250 deliveries. [2]

- 3 (a) Factorise completely $2ab^2 - 8ab$. [1]
- (b) Expand and simplify $8b(a - 2) - 4a(3 - b)$. [2]
- (c) Express $\frac{2x}{9} + \frac{2(x-1)}{3}$ as a single fraction. [3]
- 4 A man cycled from town A to town B at an average speed of 18 km/h for 90 minutes. He then travelled 6 km from town B to town C in 45 minutes.
- Find
- (a) the time he would reach town C if he left town A at 10 15, [1]
- (b) the distance he travelled from town A to town B, [2]
- (c) his average speed in his whole journey from town A to town C. [3]
Give your answer in m/s, correct to three significant figures.

95

- 5 (a) In 2012, Mr Lim spent $\frac{1}{6}$ of his monthly income on rent, $\frac{1}{4}$ on food, and $\frac{1}{5}$ of the remainder on clothes. His monthly income is \$5400.
- (i) In any particular month, calculate the amount of money he spent on clothes, [2]
- (ii) calculate how much more money he spent on food than on rent. [2]
- (b) In 2013, Mr Lim's total expenditure on rent, food and clothes increased by 6%. If the rent remained the same, and the amount spent on food increased by 10%, express the increase in the amount spent on clothes as a percentage of the total expenditure in 2012. [3]

- 6 (a) In the figure below, $AEFG$ and CFD are straight lines and $AB \parallel CD$.
 $\angle ECF = 50^\circ$ and $\angle DFG = 20^\circ$.

Find

- (i) $\angle EFC$, [1]
- (ii) $\angle AEC$. [2]

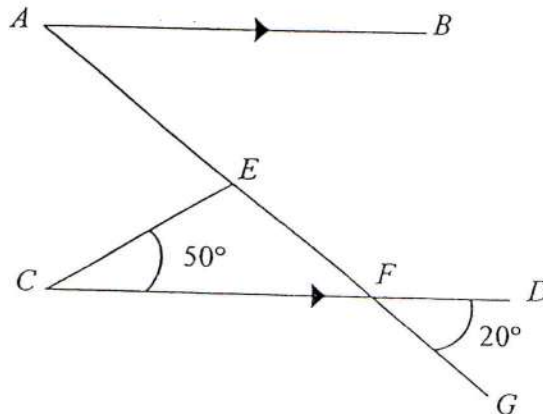

- (b) The pie chart shows the distribution of participants in a marathon.

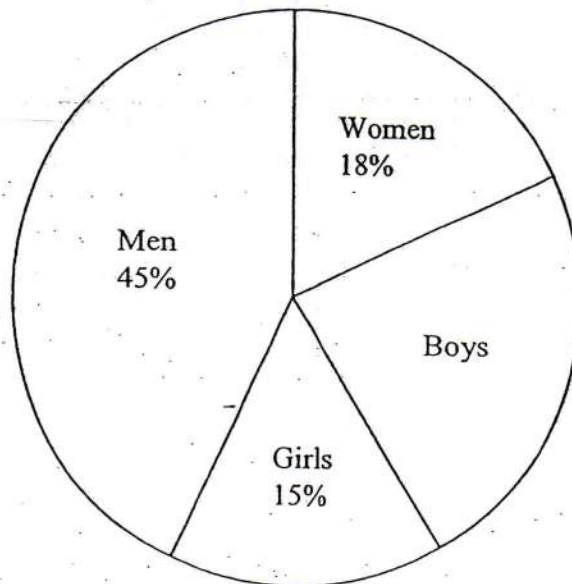

- (i) Find the ratio of the number of boys to the number of women taking part in the marathon. [1]
- (ii) There are 621 more men than boys.
Find the total number of men and boys participating in the marathon. [2]
- (iii) Calculate the angle of the sector representing the number of girls participating in the marathon. [1]

97

- 7 Consider the number patterns in the table below.

Line 1:	$3^2 - 2^2 = 5$
Line 2:	$4^2 - 3^2 = 7$
Line 3:	$5^2 - 4^2 = 9$
Line 4:	
⋮	
Line 7:	
⋮	
Line n :	$p^2 - q^2 = r$

- (a) Write down the pattern for Line 4 and Line 7. [2]
- (b) Write down an expression, in-terms of n , for
- (i) p , [1]
- (ii) q , [1]
- (iii) r . [1]
- (c) Find the integer values of p and q when $r = 83$. [2]

- 8 (a) (i) When an ez-link card is scanned at the MRT gantry, the display shows the stored value in the ez-link card.
Justin used his ez-link card to travel on the MRT train from Orchard to Yishun Station.
At the Orchard station, the display showed \$1.45.
After he alighted at Yishun Station, the display showed –\$0.85.
How much did the ride cost? [2]
- (ii) At Yishun Station, Justin topped up his ez-link card with \$30.
What is the stored value of his card now? [1]

- (b) Tom and Jerry took part in a game whereby coloured balls are drawn from a bag. There are 5 blue balls, numbered 1 to 5, and 5 red balls, numbered 1 to 5, in the bag.
Drawing a blue ball leads to the deduction of points and drawing a red ball leads to gain of points. For example, if a blue ball with the number 5 on it is drawn, 5 points will be deducted and if a red ball with the number 4 is drawn, 4 points will be gained.
Tom and Jerry each took turns to draw a ball from the bag for 4 rounds and the balls are replaced in the bag after each draw.
The player with the most number of points wins the game.

- (i) Calculate the maximum and the minimum number of points a player can obtain. [2]

The table below represents the balls that were drawn by Tom and Jerry in the 4 rounds.

Round	1	2	3	4
Tom	Red, 3	Blue, 4	Red, 1	Red, 3
Jerry	Red, 4	Blue, 1	Red, 5	Blue, 2

- (ii) Find the points obtained by Tom and Jerry respectively.
Who won the game? [2]

99

- 9 The figure below shows the floor plan of a function room in a hotel.
The function room is made up of a semi-circle ABC with diameter AC , a rectangle $ACDF$ and an isosceles triangle DEF .

$CA = 36$ m, $CD = 17$ m, $DE = EF = 25.5$ m and $BE = 53$ m.

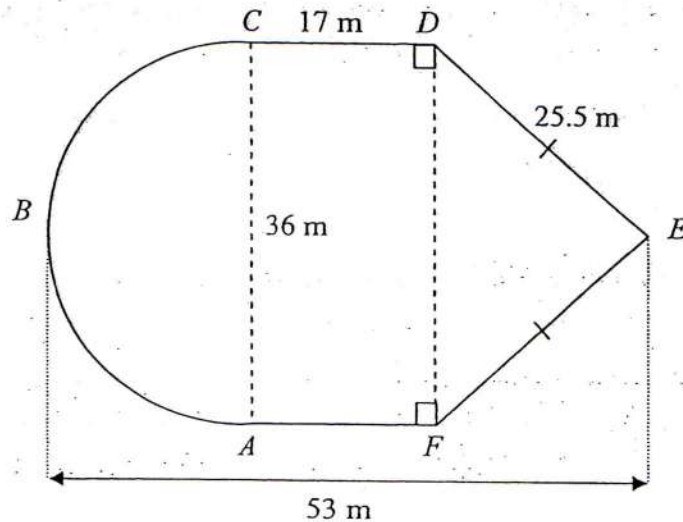

[Take $\pi = 3.142$]

- (a) Calculate
- the perimeter of the function room, [2]
 - the area of the function room. [3]
- (b) (i) The entire floor of the function room is to be carpeted.
Calculate the cost of carpeting the entire function room if the price of the carpet is \$7.65 per square metre. [1]
- (ii) A goods and services tax (GST) of 7% is imposed on the total cost of carpeting the entire function room.
Find the total cost of carpeting the entire function room inclusive of GST. [2]

END OF PAPER



聖嬰中學
HOLY INNOCENTS' HIGH SCHOOL

MID-YEAR EXAMINATION 2014
SECONDARY 1 EXPRESS

MATHEMATICS

4016/02

Paper 2 Marking Scheme

Name : _____

Date : 14 May 2014

Register No : _____

Duration : 1 h 30 min

Class : _____

Additional Materials: 4 sheets of Writing Paper

INSTRUCTIONS TO STUDENTS

Write your index number and name on all the work you hand in.

Write in dark blue or black pen.

You may use a pencil for any diagrams or graphs.

Do not use staples, paper clips, highlighters, glue or correction fluid.

Answer **all** questions.

If working is needed for any question, it must be shown with the answer.

Omission of essential working will result in loss of marks.

Calculators should be used where appropriate.

If the degree of accuracy is not specified in the question, and if the answer is not exact, give the answer to three significant figures. Give answers in degrees to one decimal place.

For π , use either your calculator value or 3.142, unless the question requires the answer in terms of π .

The number of marks is given in brackets [] at the end of each question or part question.

The total marks for this paper is 60.

Setter: Ms Nicole Goh

1(a) (i) $x + 3$B1

(ii) $2(x + 3) = 2x + 6$B1 (can accept $2(x + 3)$)

(b) $x + x + 3 + 2(x+3)$M1

$= x + x + 3 + 2x + 6$

$= 4x + 9$A1

(c) $4(4x + 9) = 169$M1

$16x + 36 = 169$

$16x = 133$

$x = 8.3125$

$8.3125 + 3 = 11.3125$ hours Benjamin worked 11.3 hours.....A1

2(a)(i) $\$50 + \$3.50(75)$

$= \$312.50$B1

(a)(ii) $\$372 - \$50 = \$322$M1

$\$322 \div \$3.50 = 92$

He made 92 deliveries.....A1

(iii) $A = 50 + 3.50n$B1

(b) $\$600 + \$1.50(250 - 100)$

$= \$825$

Mr Lim earns \$825

} M1

$\$50 + \$3.50(250)$

$= \$925$

Mr Tan earns \$925.

Mr Tan earns more.....A1

$$3(a) \ 2ab(b-4) \dots\dots\dots B1$$

$$(b) \ 8b(a-2) - 4a(3-b)$$

$$= 8ab - 16b - 12a + 4ab \dots\dots\dots M1$$

$$= 12ab - 16b - 12a \dots\dots\dots A1$$

$$(c) \ \frac{2x}{9} + \frac{2(x-1)}{3}$$

$$= \frac{2x}{9} + \frac{2x-2}{3} \dots\dots\dots M1(\text{for expansion})$$

$$= \frac{2x}{9} + \frac{6x-6}{9} \dots\dots\dots M1(\text{for common denominator})$$

$$= \frac{8x-6}{9} \dots\dots\dots A1$$

$$4(a) \ 90 + 45 = 135 \text{ min} = 2\text{h } 15 \text{ min}$$

$$10 \ 15 + 2\text{h } 15 \text{ min} = 12 \ 30 \dots\dots\dots B1$$

$$(b) \ 18 \times \frac{90}{60} \dots\dots\dots M1$$

$$= 27 \text{ km} \dots\dots\dots A1$$

$$(c) \ (27 + 6) \div \frac{45 + 90}{60} \dots\dots\dots M1$$

$$= 33 \div \frac{135}{60}$$

$$= 14 \frac{2}{3} \text{ km/h} \dots\dots\dots A1$$

$$= 4 \frac{2}{27} \text{ m/s} \dots\dots\dots A1(\text{can accept } 4.07 \text{ m/s})$$

$$5(a)(i) \quad 1 - \frac{1}{6} - \frac{1}{4} = \frac{7}{12} \dots\dots\dots M1(\text{find remainder})$$

$$\frac{1}{5} \times \frac{7}{12} = \frac{7}{60}$$

$$\frac{7}{60} \times \$5400 = \$630$$

He spent \$630 on clothes.....A1

$$(ii) \text{ Amount spent on rent} = \frac{1}{6} \times \$5400 = \$900$$

$$\text{Amount spent on food} = \frac{1}{4} \times \$5400 = \$1350$$

} M1

$$\text{Difference} = \$1350 - \$900 = \$450$$

He spent \$450 more on food than on rent.....A1

$$(b) \text{ Total original amount spent} = \$630 + \$900 + \$1350 = \$2880$$

$$\text{Total new amount spent} = \frac{106}{100} \times \$2880 = \$3052.80 \dots\dots\dots M1$$

$$\text{New amount spent on food} = \frac{110}{100} \times \$1350 = \$1485$$

$$\text{New amount spent on clothes} = \$3052.80 - \$1485 - \$900 = \$667.80 \dots\dots\dots M1$$

$$\text{Percentage increase} = \frac{667.80 - 630}{2880} \times 100\% = 1.3125\% \dots\dots A1(\text{accept } 1\frac{5}{16}\%)$$

$$6(a) \angle EFC = 20^\circ \dots\dots\dots B1$$

$$\begin{aligned} \angle CEF &= 180^\circ - 20^\circ - 50^\circ \\ &= 110^\circ \dots\dots\dots M1 \end{aligned}$$

$$\begin{aligned} \angle AEC &= 180^\circ - 110^\circ \\ &= 70^\circ \dots\dots\dots A1 \end{aligned}$$

$$6(b)(i) \text{ Boys} = 100\% - 18\% - 15\% - 45\% = 22\%$$

Boys : Women

$$22 : 18$$

$$11 : 9 \dots\dots\dots B1$$

$$(ii) 45\% - 22\% = 23\%$$

$$23\% \text{ rep } 621 \dots\dots\dots M1$$

$$1\% \text{ rep } 27$$

$$67\% \text{ rep } 1809$$

There are 1809 men and boys \dots\dots\dots A1

$$(iii) \frac{15}{100} \times 360^\circ$$

$$= 54^\circ \dots\dots\dots B1$$

$$7(a) \text{ Line 4: } 6^2 - 5^2 = 11 \dots\dots\dots B1$$

$$\text{Line 7: } 9^2 - 8^2 = 17 \dots\dots\dots B1$$

$$(b)(i) p = n + 2 \dots\dots\dots B1$$

$$(ii) q = n + 1 \dots\dots\dots B1$$

$$(iii) r = n + 2 + n + 1 = 2n + 3 \dots\dots\dots B1$$

$$(b) p + q = 83$$

$$2n + 3 = 83$$

$$2n = 80$$

$$n = 40$$

$$p = 40 + 2 = 42 \dots\dots\dots B1$$

$$q = 40 + 1 = 41 \dots\dots\dots B1$$

$$8(a) \text{ (i) } \$1.45 - (-\$0.85) \dots\dots\dots \text{M1}$$

$$= \$2.30 \dots\dots\dots \text{A1}$$

$$\text{(ii) } -\$0.85 + \$30 = \$29.15 \dots\dots\dots \text{B1}$$

$$\text{(b)(i) Max} = 5(4) = 20 \dots\dots\dots \text{B1}$$

$$\text{Min} = (-5)(4) = -20 \dots\dots\dots \text{B1}$$

(ii) Tom

$$= 3 - 4 + 1 + 3$$

$$= 3$$

Jerry

$$= 4 - 1 + 5 - 2$$

$$= 6$$

} M1

Jerry won the game. A1

$$9(a) \text{ Perimeter} = \left(\frac{1}{2} \times 3.142 \times 36 \right) + 2(17) + 2(25.5) \dots\dots\dots \text{M1 (correct formula for circle)}$$

$$= 141.556 \text{ m} \dots\dots\dots \text{A1}$$

$$\text{(b) Area} = \left(\frac{1}{2} \times 3.142 \times 18^2 \right) + (17 \times 36) + \left(\frac{1}{2} \times 36 \times 18 \right) \dots\dots\dots \text{M2 (correct formula for circle and}$$

triangle)

$$= 1445.004 \text{ m}^2 \dots\dots\dots \text{A1}$$

$$\text{(c) Cost of carpeting} = 1445.004 \times \$7.65$$

$$= \$11054.28$$

$$\approx \$11054 \dots\dots\dots \text{B1}$$

$$\text{(d) } \frac{107}{100} \times \$11054.28 \dots\dots\dots \text{M1}$$

$$= \$11828.08 \dots\dots\dots \text{A1 (ans must be in 2 dp)}$$



YISHUN SECONDARY SCHOOL

We Seek, We Strive, We Soar

MID-YEAR EXAMINATION

Name : _____ Reg. No : _____ Class: _____

Calculator Model: _____

SEC1EXPRESS

DATE: 12MAY 2014

MATHEMATICS

MAX MARKS: 80

DURATION: 2 HOURS

READ THESE INSTRUCTIONS FIRST

Write your name, register number and class in the spaces provided at the top of this page.

Write in dark blue or black pen.

You may use a pencil for any diagrams or graphs.

Do not use staples, paper clips, highlighters, glue or correction fluid.

Answer **all** questions.

If working is needed for any question it must be shown with the answer.

Omission of essential working will result in loss of marks.

The use of an approved scientific calculator is expected, where appropriate.

If the degree of accuracy is not specified in the question, and if the answer is not exact, give the answer to three significant figures. Give answers in degrees to one decimal place.

For π , use either your calculator value or 3.142, unless the question requires the answer in terms of π .

At the end of the examination, fasten all your work securely together.

The number of marks is given in brackets [] at the end of each question or part question.

The total of the marks for this paper is 80.

113

This document consists of 16 printed pages including the cover page

[Turn Over]

Answer all the questions.

1. Calculate

(a) $\frac{\left(5\frac{1}{2}\right)^2}{\left(1-\frac{1}{3}\right)^3}$, giving your answer correct to the nearest integer.

Answer(a) [1]

(b) $\sqrt[3]{12.3 - 4\pi + 0.29}$, giving your answer correct to 3 significant figures.

Answer(b) [1]

2. Given that $p = 2$ and $q = -3$, fill in the blanks with '<', '= ' or '>'.

(a) $2q \div 3 + 2$ ____ 3

Answer(a) [1]

(b) $5q^2 - 36p$ ____ -29

Answer(b) [1]

3. If you add 7 to a certain integer, the result is a positive number, but if you add 5 to it, the result is a negative number. Find this integer.

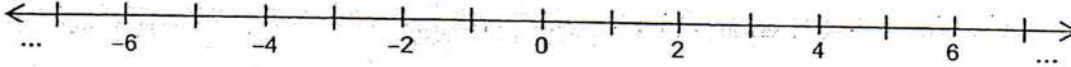

Answer [1]

4. By rounding each number to 1 significant figure, estimate the value of $\frac{8.4 \times \sqrt[3]{998}}{0.432 \times 31.99}$.
Show your working.

Answer [2]

5. Arrange the following numbers in ascending order.

$$-4.7, \frac{19}{4}, -4.7, \sqrt{22}$$

Answer 115 [2]

6. (a) Express 5.973 correct to 1 decimal place.

Answer(a)..... [1]

(b) Express 364.51 correct to 2 significant figures.

Answer(b)..... [1]

(c) Use your answers in parts (a) and (b) to estimate the value of $364.51 \div 5.973$.

Answer(c) [1]

7. Consider the following eight numbers:

$$\sqrt{36}, 81, 17, \sqrt{169}, 5^2, \pi, \sqrt{7}, \frac{22}{7}$$

Write down

(a) the square number(s),

Answer(a) [1]

(b) the prime number(s),

Answer(b) [1]

(c) the irrational number(s).

Answer(c) [1]

8. Written as a product of its prime factors,

$$p \text{ is } 2^6 \times 3^3,$$

$$q \text{ is } 2^3 \times 3 \times 5^2,$$

$$r \text{ is } 2^2 \times 3^2 \times 7.$$

Find

(a) the cube root of p , giving your answer in index notation,

Answer(a) [1]

(b) the lowest common multiple of p , q and r , giving your answer in index notation,

Answer(b) [1]

(c) the greatest number that will divide p , q and r exactly.

Answer(c) [1]

9. Factorise each of the following completely:

(a) $15y - 12y^2$,

Answer(a) [1]

(b) $a(4b - 5c) + (5c - 4b)$.

Answer(b) [2]

117

10. Last month, Nicole spent $\frac{4}{9}$ of her monthly salary on food, $\frac{1}{5}$ of her monthly salary on transportation and saved the rest.

(i) What fraction of her salary did she save?

Answer(i) [1]

(ii) Nicole spent a further $\frac{2}{3}$ of her savings on a present for her mother.

What fraction of her salary did she have left?

Answer(ii) [2]

11. Solve the following equations:

(a) $3a + 2 = 4a - 10,$

Answer(a) [1]

(b) $\frac{8}{2y - 1} = 7.$

Answer(b) [2]

12. Three traffic lights along a street turn red at regular intervals of 1 minute, 1 minute 10 seconds and 3 minutes 30 seconds respectively. If all the traffic lights turned red at the same time at 0830, find the next time this will occur again.

Answer [3]

13. The diagram below shows a rectangle with its length and breadth as indicated. Find the value of p and q .

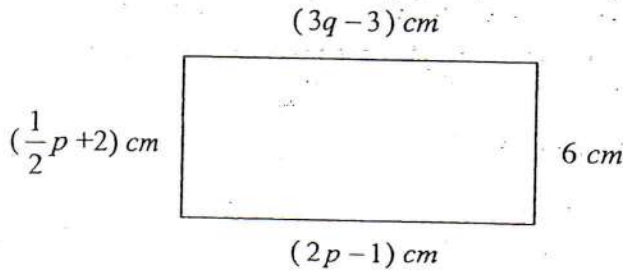

Answer $p =$

$q =$ [3]

109

14. An interior angle of a regular polygon is four times its exterior angle.
Find the number of sides of the polygon.

Answersides [3]

15. Jess travelled from CityA to CityB using different modes of transport. She covered $\frac{5}{9}$ of her journey by train, 0.75 of the remainder by bus and the rest of the journey on foot.

(a) Find the fraction of the journey that she travelled on foot.

Answer(a)..... [2]

(b) If she travelled 35 km more by train as compared to the journey by bus, how far apart are the 2 cities?

Answer(b)km [2]

16. In the diagram below, the straight line PQR is parallel to ST and QS is parallel to RU . $PS = QS$, $\angle SQR = 116^\circ$ and $\angle UTS = 39^\circ$.

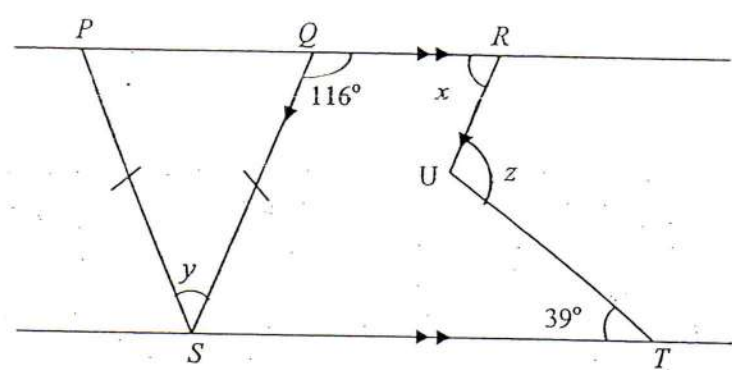

State all geometrical reasons clearly.

Calculate

- (a) $\angle x$,

Answer(a)° [1]

- (b) $\angle y$,

Answer(b)° [1]

- (c) $\angle z$.

Answer(c)° [2]

17. Simplify the following expressions:

(a) $1 + \frac{a+1}{2} + \frac{3}{2}$,

Answer(a) [2]

(b) $\frac{2x-5y}{7} - \frac{x-6y}{2}$.

Answer(b) [2]

18. "A prime number is a whole number greater than 1, with exactly 2 factors, 1 and itself."

Given that p and q are prime numbers, determine if each statement is true or false.

Explain your answer.

- (a) $5p$ is a prime number.

Answer(a)
.....[2]

- (b) $q + q + q + q$ is a composite number.

Answer(b)
..... [2]

19. Simplify the following expressions:

(a) $-5a + 8b + 2a - b$

Answer(a) [1]

(b) $6(2m - n) + 2n - m$,

Answer(b) [2]

(c) $4t - [5s - (t + s)]$.

Answer(c) [2]

20. Katie bought 2 vanguard sheets each measuring 70 cm by 90 cm.
She cut out square cards of identical size from the vanguard sheets such that there was no wastage.

(i) What is the largest possible length of the side of each square card she cut out?

Answer(i)cm [2]

(ii) What is the total number of square cards she cut out such that there was no wastage?

Answer(ii)square cards [1]

(iii) If Katie wants to use an equal number of square cards to write her revision notes for each of her 5 subjects.

What is the maximum number of square cards she can use for each subject?

How many square card(s) will be left over?

Answer(iii)square cards used [1]

.....square card(s) left [1]

21. The Benjamin Sheares Bridge is divided into three sections.
 The first section is x m long.
 The last section is 250m longer than the first section.
 The middle section is twice as long as the last section.

(i) Write down an expression, in terms of x for,

(a) the length of the last section,

Answer(i)(a).....m [1]

(b) the length of the middle section.

Answer(i)(b).....m [1]

(ii) The Benjamin Sheares Bridge is 1.8km long.

Write down an equation, in terms of x , to represent this information, and show that it reduces to $1800 = 4x + 750$.

Answer:

[1]

(iii) Solve the equation, and find the length of the first section of the bridge.

Answer(iii)m [2]

125

22. In the answer space, construct and label a quadrilateral $PQRS$ such that $\angle PQR = 85^\circ$, $\angle QRS = 65^\circ$, $PQ = 6\text{cm}$ and $QR = 8.3\text{cm}$.

The side RS is drawn in the answer space.

- (a) Using ruler, protractor and compasses only, complete the quadrilateral. [2]

Answer:



- (b) On the same diagram, construct
- (i) the bisector of angle QPS , [1]
 - (ii) the perpendicular bisector of side RS . [1]

- (c) These two bisectors meet at T .

Mark the point T , measure and write down the size of $\angle SPT$.

Answer(c)° [2]

23. (a) Find the value of x .
[Hint: Look out for 'triangles'.]

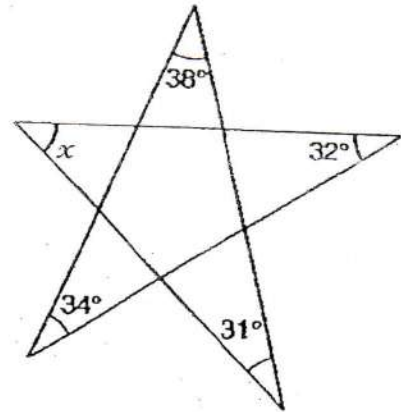

Answer(a)..... $^\circ$ [2]

(b) The diagram shows three regular pentagons.
Find the value of p and of q .

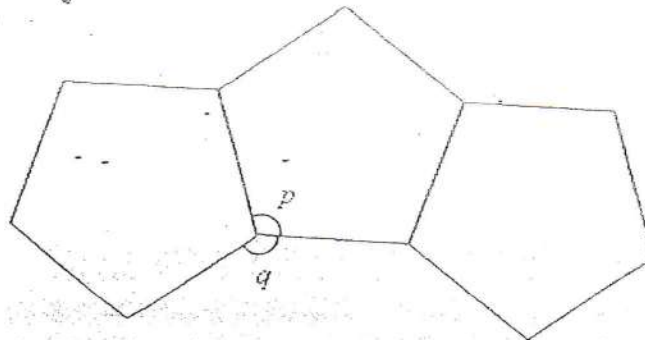

Answer(b) $p =$ $^\circ$ [2]

$q =$ $^\circ$ [1]

127

(c) In the diagram, AB , DE and FCG are parallel.

Given that $\angle ABC = 84^\circ$ and $\angle BCD = 39^\circ$.

Find reflex $\angle CDE$.

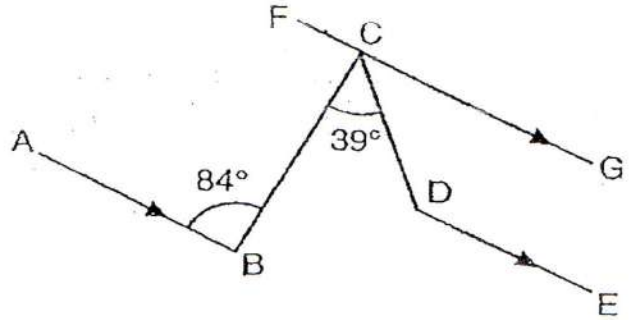

Answer(c)° [2]

ANSWER SCHEME			
1(a)	102	13	$p = 8$ $q = 6$
1(b)	0.287	14	$n = 10$
2(a)	<	15(a)	$\frac{1}{9}$
2(b)	>	15(b)	157.5 km
3	$x = -6$	16(a)	64° (int \angle)
4	$6\frac{2}{3}$	16(b)	52° (base of iso triangle)
5	$-47, -47, \sqrt{2}$	16(c)	103° (alt \angle)
6(a)	6.0	17(a)	$\frac{a+6}{2}$
6(b)	360	17(b)	$\frac{32y-3x}{14}$
6(c)	60	18(a)	No Using an integer to substitute into p and explain that it is not a prime number. E.g. if $p = 2$, $2p = 10$ which is not a prime number. OR It has more than 2 factors other than 1 and itself. e.g. $p / 5$ (any 1)
7(a)	81, 5^2	18(b)	Yes. Reasoning must be general. E.g. Since $q + q + q + q = 4q$. It has more than 2 factors other than 1 and itself. (4, 2, q, any 1 mentioned)
7(b)	17, $\sqrt{169}$	19(a)	$-3a + 7b$
7(c)	$\Pi, \sqrt{7}$	19(b)	$11m - 4n$
8(a)	$2^2 \times 3$	19(c)	$5t - 4s$
8(b)	$2^6 \times 3^2 \times 5^2 \times 7$	20(i)	10
8(c)	12	20(ii)	126
9(a)	$3y(5 - 4y)$	20(iii)	25 square cards used. 1 square card left.
9(b)	$(a - 1)(4b - 5c)$	21(i)(a)	$(x + 250)$
10(i)	$\frac{16}{45}$	21(i)(b)	$2x + 500$
10(ii)	$\frac{16}{135}$	21(iii)	$x = 262.5$
11(a)	$a = 12$	22(c)	$47 (\pm 1)$
11(b)	$y = 1\frac{1}{14}$	23(a)	45°
12	0837	23(b)	$p = 108^\circ, q = 144^\circ$
		23(c)	225°





BEATTY SECONDARY SCHOOL
END-OF-YEAR EXAMINATION 2014

SUBJECT : Mathematics

LEVEL : Secondary 1 Express

PAPER : 1

DURATION : 1 hour 15 minutes

SETTER : Mr Anthony Goh

DATE : 1 October 2014

CLASS :	NAME :	REG NO :
---------	--------	----------

READ THESE INSTRUCTIONS FIRST

Write your name, class and index number in the spaces on the top of this page.

Write in dark blue or black pen.

You may use a pencil for any diagrams or graphs.

Do not use staples, paper clips, highlighters, glue or correction fluid.

Answer **all** questions.

If working is needed for any question, it must be shown with the answer.

Omission of essential working will result in loss of marks.

You are expected to use a scientific calculator to evaluate explicit numerical expressions.

If the degree of accuracy is not specified in the question, and if the answer is not exact, give the answer to three significant figures. Give answers in degrees to one decimal place.

For π , use either your calculator value or 3.142, unless the question requires the answer in terms of π .

The number of marks is given in brackets [] at the end of each question or part question.

The total number of marks for this paper is 50.

For Examiner's Use
50

Answer all questions.

1 (a) Evaluate $\frac{0.301299}{\sqrt[3]{13.364 + 1.292}} + 0.071265$.

Answer (a)..... [1]

(b) Write the following set of numbers in ascending order.

$$0.422, \frac{3}{7}, -0.422, 0.42$$

Answer (b), , , [1]

(c) The temperature at the bottom of a mountain is 18°C . The temperature at the top of the mountain is -26°C . Find the difference between the two temperatures.

Answer (c) $^{\circ}\text{C}$ [1]

2 (a) Express 3150 as a product of its prime factors in index notation.

Answer (a)..... [1]

(b) Hence, express $\sqrt{3150 \times 14}$ as a product of its prime factors.

Answer (b)..... [2]

3 A football club invested \$30 million in a famous footballer. A newspaper reported that the club would have to sell 674 998 tickets to recover their investment.

(a) Correct 674 998 to two significant figures.

Answer (a)..... [1]

(b) Use your answer to (a) to estimate the cost of a ticket, correct to the nearest dollar.

Answer (b)\$..... [1]

4 Simplify

(a) $9x - 3(3x + 5y)$

Answer (a)..... [2]

(b) $\frac{2x-5y}{2} - \frac{3x-2y}{3}$

Answer (b)..... [2]

5 Samantha can type an SMS message consisting of 143 words in 2 minutes 36 seconds.

Calculate

(a) the number of words she can type in one minute,

Answer (a) words [2]

(b) the time, in seconds, she uses to type one word.

Answer (b) seconds [2]

- 6 (a) Given that $s = \frac{v^2 - u^2}{2a}$, find the value of s when $v = 4$, $u = 3$ and $a = 7$.

Answer (a) $s = \dots\dots\dots$ [1]

- (b) Factorise the following:

(i) $15xy + 10y - 40yz$

Answer (b)(i) $\dots\dots\dots$ [1]

(ii) $3p(a - 8b) - 7q(8b - a)$

Answer (b)(ii) $\dots\dots\dots$ [2]

- 7 By selling a sofa for \$408, a retailer suffers a loss of 4%.
Find the cost price of the sofa.

Answer \$..... [2]

- 8 Study the pattern below.



Pattern 1

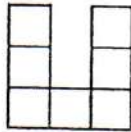

Pattern 2

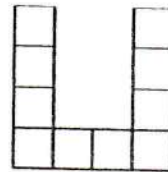

Pattern 3

- (a) Draw Pattern 4.

[1]

- (b) Write down an expression, in terms of n , for the number of squares in Pattern n .

Answer (b) [1]

- (c) There are 136 squares in Pattern N . Find the value of N .

Answer (c) $N =$ [1]

9 Solve

(a) $3x - 5(3 - x) = 41$

Answer (a) $x = \dots\dots\dots$ [2]

(b) $\frac{x+7}{4} = \frac{3x-5}{5}$

Answer (b) $x = \dots\dots\dots$ [2]

- 10 In the diagram below, $ABCD$ is a rhombus. BD cuts AC at X and $\angle CAD = 50^\circ$. Y is on AD and W is on BC such that $YX = AX$ and WXY is a straight line.

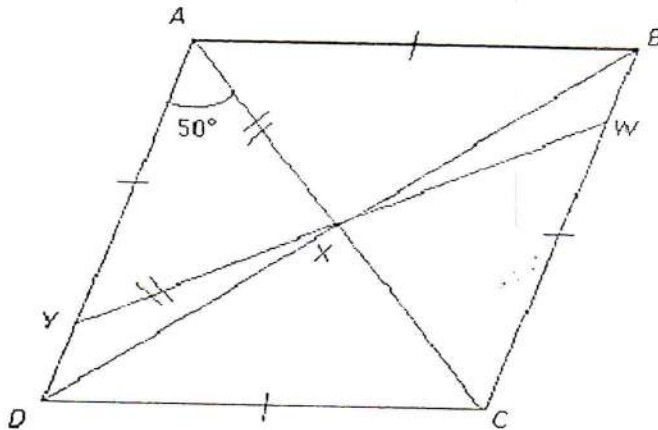

Calculate

(a) $\angle AXY$,

Answer (a) $^\circ$ [1]

(b) $\angle DXY$,

Answer (b) $^\circ$ [1]

(c) $\angle BWY$,

Answer (c) $^\circ$ [2]

- 11 The pie chart illustrates John's expenditure and savings in September.

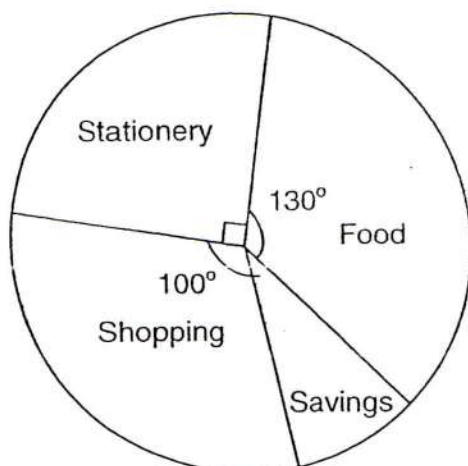

- (a) What percentage of his money was spent on shopping?

Answer (a) % [2]

- (b) If he spent \$70 on shopping, how much money did he spend in total?

Answer (b) \$ [2]

12 The graph below shows the cost of a taxi fare for a journey up to 5 kilometres.

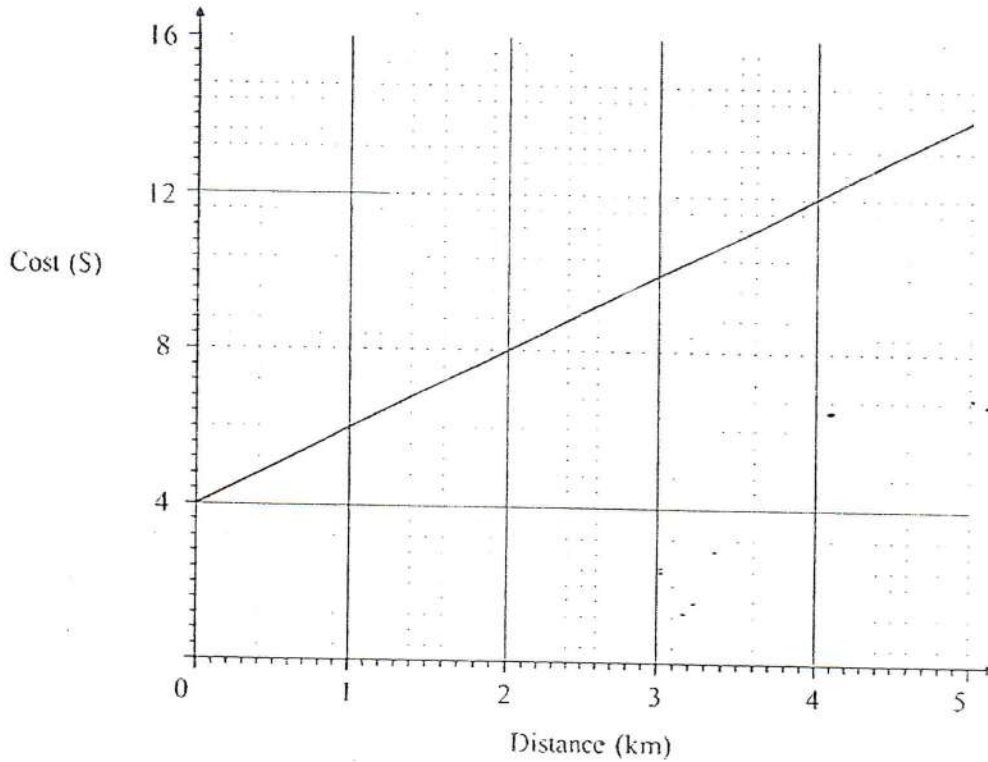

(a) What is the taxi fare for a journey of 1 km?

Answer (a) \$..... [1]

(b) If the taxi fare was \$12, how far was the journey?

Answer (b)..... km [1]

(c) Calculate the gradient of the graph.

Answer (c)..... [1]

(d) Explain what the gradient means.

.....

..... [1]

13

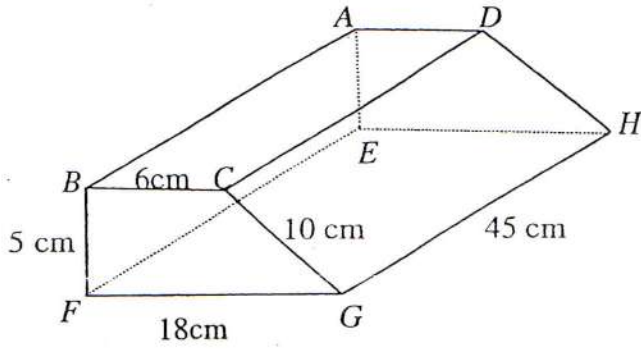

The diagram represents a prism. The faces of $ABCD$ and $EFGH$ are horizontal. The faces $ABFE$, $BCGF$ and $ADHE$ are vertical.
 $BC = AD = 6$ cm, $CG = DH = 10$ cm, $BF = AE = 5$ cm, $FG = EH = 18$ cm and $GH = FE = BA = CD = 45$ cm.

Calculate

(a) the volume of the prism,

Answer (a) cm^3 [3]

(b) the total surface area of the prism.

141
 Answer (b) cm^2 [3]

- 14 The diagram shows a cylindrical pipe of height measuring 12 cm which has an internal radius of 4.5 cm and external radius of 5 cm.

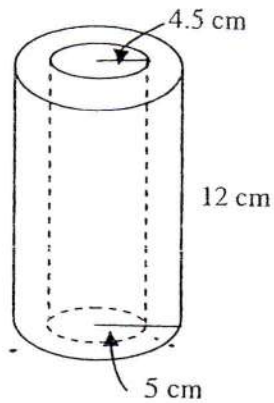

Find the total surface area of the pipe.

Answer..... cm² [3]

End of Paper



BEATTY SECONDARY SCHOOL
END-OF-YEAREXAMINATION 2014

Teacher's
Copy

SUBJECT : Mathematics

LEVEL : Secondary 1 Express

PAPER :1

DURATION : 1 hour 15 minutes

SETTER : MrAnthony Goh

DATE :1 October 2014

CLASS :	NAME :	REG NO :
---------	--------	----------

READ THESE INSTRUCTIONS FIRST

Write your name, class and index number in the spaces on the top of this page.

Write in dark blue or black pen.

You may use a pencil for any diagrams or graphs.

Do not use staples, paper clips, highlighters, glue or correction fluid.

Answer **all** questions.

If working is needed for any question, it must be shown with the answer.

Omission of essential working will result in loss of marks.

You are expected to use a scientific calculator to evaluate explicit numerical expressions.

If the degree of accuracy is not specified in the question, and if the answer is not exact, give the answer to three significant figures. Give answers in degrees to one decimal place.

For π , use either your calculator value or 3.142, unless the question requires the answer in terms of π .

The number of marks is given in brackets [] at the end of each question or part question.

The total number of marks for this paper is **50**.

For Examiner's Use
50

This paper consists of 12 printed pages (including this cover page)

145

[Turn over

Answer all questions.

1 (a) Evaluate $\frac{0.301299}{\sqrt[3]{13.364 + 1.292}} + 0.071265$.

0.153

[B1]

Answer (a)..... [1]

(b) Write the following set of numbers in ascending order.

$0.422, \frac{3}{7}, -0.422, 0.4\dot{2}$

$-0.422, 0.422, 0.4\dot{2}, \frac{3}{7}$ [B1] ($\frac{3}{7} = 0.42857\dots$)

Answer (b)..... [1]

(c) The temperature at the bottom of a mountain is 18°C . The temperature at the top of the mountain is -26°C . Find the difference between the two temperatures.

$18 - (-26) = 44^\circ\text{C}$ [B1]

Answer (c)..... $^\circ\text{C}$ [1]

2 (a) Express 3150 as a product of its prime factors in index notation.

$3150 = 2 \times 3^2 \times 5^2 \times 7$ [B1]

Answer (a)..... [1]

(b) Hence, express $\sqrt{3150 \times 14}$ as a product of its prime factors

$\sqrt{3150 \times 14} = \sqrt{2 \times 3^2 \times 5^2 \times 7 \times 2 \times 7}$ [M1]

$= \sqrt{2^2 \times 3^2 \times 5^2 \times 7^2}$

$= 2 \times 3 \times 5 \times 7$ [A1]

Answer (b)..... [2]

- 3 A football club invested \$30 million in a famous footballer. A newspaper reported that the club would have to sell 674 998 tickets to recover their investment.

(a) Correct 674 998 to two significant figures.

670 000

[B1]

Answer (a)..... [1]

(b) Use your answer to (a) to estimate the cost of a ticket, correct to the nearest dollar.

$$\text{Cost of ticket} = \$ \frac{30000000}{670000}$$

$$= \$44.78$$

$$= \$45$$

[B1]

Answer (b) \$..... [1]

- 4 Simplify the following

(a) $9x - 3(3x + 5y)$

$$9x - 3(3x + 5y) = 9x - 9x - 15y \quad [\text{M1}]$$

$$= -15y \quad [\text{A1}]$$

Answer (a)..... [2]

(b) $\frac{2x-5y}{2} - \frac{3x-2y}{3}$

$$\frac{2x-5y}{2} - \frac{3x-2y}{3} = \frac{3(2x-5y) - 2(3x-2y)}{6} \quad [\text{M1}]$$

$$= \frac{6x - 15y - 6x + 4y}{6}$$

$$= -\frac{11}{6}y \quad [\text{A1}]$$

Note: $-1.83y$ is accepted as the answer is exact.

Answer (b)..... [2]

- 5 Samantha can type an SMS message consisting of 143 words in 2 minutes 36 seconds.
Calculate

- (a) the number of words she can type in one minute,

$$\begin{aligned} \text{Number of words in one minute} &= \frac{143}{2\frac{36}{60}} && \text{[M1]} \\ &= 55 \text{ words} && \text{[A1]} \end{aligned}$$

Answer (a) words [2]

- (b) the time, in seconds, she uses to type one word.

$$\begin{aligned} \text{Time taken to type one word} &= \frac{60}{55} && \text{[M1]} \\ &= 1\frac{11}{12}, \frac{13}{12} \text{ or } 1.09 \text{ seconds} && \text{[A1]} \end{aligned}$$

Answer (b) seconds [2]

- 6 (a) Given that $s = \frac{v^2 - u^2}{2a}$, find the value of s when $v = 4$, $u = 3$ and $a = 7$.

$$\begin{aligned} s &= \frac{v^2 - u^2}{2a} = \frac{(4)^2 - (3)^2}{2 \times 7} \\ &= \frac{1}{2} \end{aligned} \quad \text{[B1]}$$

Answer (a) $s = \dots\dots\dots$ [1]

- (b) Factorise the following:

- (i) $15xy + 10y - 40yz$

$$15xy + 10y - 40yz = 5y(3x + 2 - 8z) \quad \text{[B1]}$$

Answer (b)(i) $\dots\dots\dots$ [1]

- (ii) $3p(a - 8b) - 7q(8b - a)$

$$\begin{aligned} 3p(a - 8b) - 7q(8b - a) &= 3p(a - 8b) - 7q(-1)(a - 8b) \\ &= 3p(a - 8b) + 7q(a - 8b) \quad \text{[M1]} \\ &= (3p + 7q)(a - 8b) \quad \text{[A1]} \end{aligned}$$

Answer (b)(ii) $\dots\dots\dots$ [2]

- 7 By selling a sofa for \$408, a retailer suffers a loss of 4%.
Find the cost price of the sofa.

Let the original price be \$x.

$$\text{Selling price} = 0.96x = 408$$

$$x = \frac{408}{0.96} \quad [\text{M1}]$$

$$= 425 \quad [\text{A1}]$$

Answer \$..... [2]

- 8 Study the pattern below.

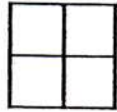

Pattern 1

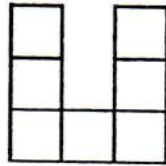

Pattern 2

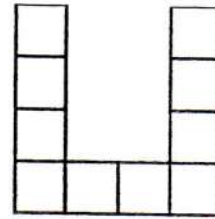

Pattern 3

- (a) Draw Pattern 4.

[1]

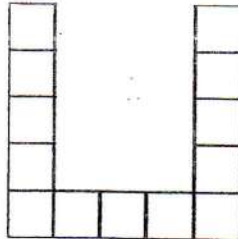

[B1]

- (b) Write down an expression, in terms of n , for the number of squares in Pattern n .

$$T_n = 4 + 3(n-1)$$

$$= 4 + 3n - 3$$

$$= 3n + 1 \quad [\text{B1}]$$

Answer (b) [1]

- (c) There are 136 squares in Pattern N . Find the value of N .

$$3N + 1 = 136$$

$$3N = 135$$

$$N = 45 \quad [\text{B1}]$$

Answer (c) $N =$ [1]

9 Solve

(a) $3x - 5(3 - x) = 41$

$$3x - 5(3 - x) = 41$$

$$3x - 15 + 5x = 41$$

$$8x = 56$$

$$x = 7$$

[M1] expand out

[A1]

Answer (a) $x = \dots\dots\dots$ [2]

(b) $\frac{x+7}{4} = \frac{3x-5}{5}$

$$\frac{x+7}{4} = \frac{3x-5}{5}$$

$$5(x+7) = 4(3x-5) \quad \text{[M1]}$$

$$5x + 35 = 12x - 20$$

$$35 + 20 = 12x - 5x$$

$$7x = 55$$

$$x = \frac{55}{7} \text{ or } 7\frac{6}{7} \quad \text{[A1]}$$

Note: 7.86 is not accepted as the answer is exact.

Answer (b) $x = \dots\dots\dots$ [2]

- 10 In the diagram below, $ABCD$ is a rhombus. BD cuts AC at X and $\angle CAD = 50^\circ$. Y is on AD and W is on BC such that $YX = AX$ and WXY is a straight line.

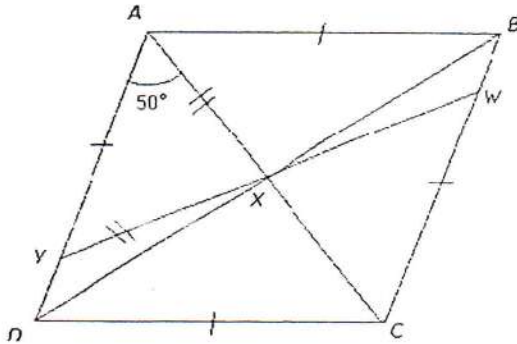

Stating your reasons clearly, calculate

- (a) $\angle AXY$,

$$\angle AYX = 50^\circ \quad (\text{base } \angle\text{s, isos } \Delta)$$

$$\begin{aligned} \angle AXY &= 180^\circ - 50^\circ - 50^\circ & (\angle \text{ sum of } \Delta) \\ &= 80^\circ \end{aligned}$$

[B1]

Answer (a) $^\circ$ [1]

- (b) $\angle DXY$,

$$\angle AXD = 90^\circ \quad (\text{property of rhombus})$$

$$\begin{aligned} \angle DXY &= 90^\circ - 80^\circ \\ &= 10^\circ \end{aligned}$$

[B1]

Answer (b) $^\circ$ [1]

- (c) $\angle BWY$,

$$\angle CXW = \angle AXY = 80^\circ \quad (\text{vert opp } \angle\text{s})$$

$$\angle ACB = \angle XAY = 50^\circ \quad (\text{alt } \angle\text{s, } AD \parallel BC) \quad [\text{M1}]$$

$$\angle BWY = \angle CXW + \angle ACB \quad (\text{ext } \angle \text{ of } \Delta)$$

$$= 80^\circ + 50^\circ$$

$$= 130^\circ$$

[A1]

$$\angle XYD = \angle AXY + \angle DAX \quad (\text{ext } \angle \text{ of } \Delta)$$

$$= 80^\circ + 50^\circ$$

$$= 130^\circ$$

OR

[M1]

$$\angle BWY = \angle XYD \quad (\text{alt } \angle\text{s, } AD \parallel BC)$$

$$= 130^\circ$$

[A1]

$$\angle XWC = \angle AYX \quad (\text{alt } \angle\text{s, } AD \parallel BC)$$

$$= 50^\circ$$

[M1]

- OR $\angle BWY = 180^\circ - \angle XWC \quad (\text{adj } \angle\text{s on st line})$

$$= 180^\circ - 50^\circ$$

$$= 130^\circ$$

[A1]

Answer (c) $^\circ$ [2]

Note:
Accept other solution with
correct workings.

- 11 The pie chart illustrates John's expenditure and savings in the month of September.

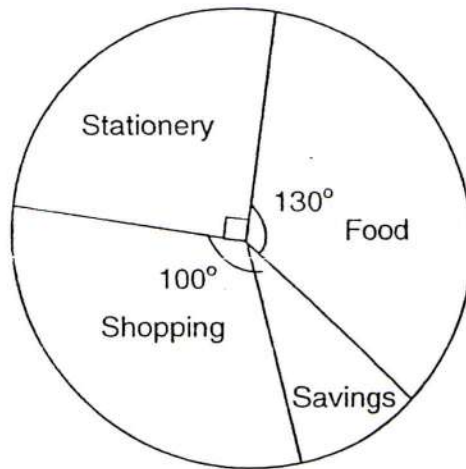

- (a) What percentage of his money was spent on shopping?

$$\text{Percentage spent on shopping} = \frac{100}{360} \times 100\% \quad [\text{M1}]$$

$$= 27\frac{7}{9}\% \text{ or } 27.8\% \quad [\text{A1}]$$

Answer (a) [2]

- (b) If he spent \$70 on shopping, how much money did he spend in total?

$$\begin{aligned} \text{Total spending is represented by } & 100^\circ + 90^\circ + 130^\circ \\ & = 320^\circ \quad [\text{M1}] \end{aligned}$$

100° represents \$70

$$\begin{aligned} \therefore \text{Spending} &= \frac{\$70}{100} \times 320 \\ &= \$224 \quad [\text{A1}] \end{aligned}$$

Answer (b) \$ [2]

12 The graph below shows the cost of a taxi fare for a journey up to 5 kilometres.

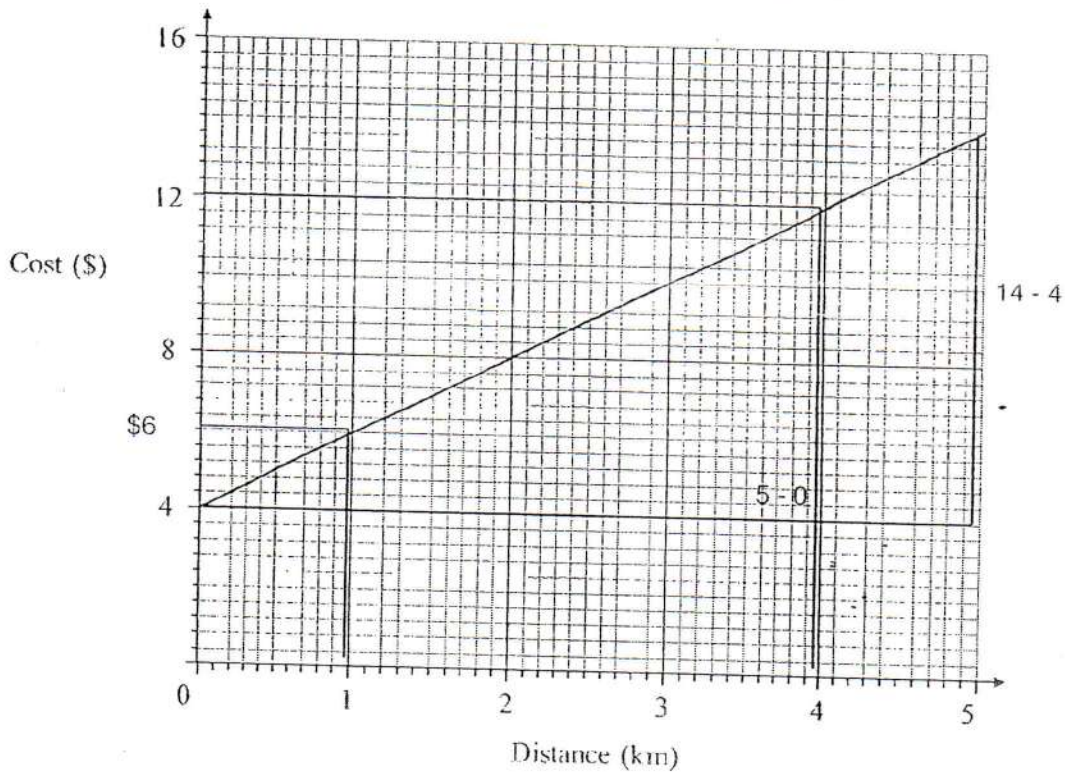

(a) What is the taxi fare for a journey of 1 km?

From the graph, the fare is \$6.00. [B1]

Answer (a) \$ [1]

(b) If the taxi fare was \$12, how far was the journey?

From the graph, the distance travelled was 4 km. [B1]

Answer (b) km [1]

(c) Calculate the gradient of the graph.

$$\begin{aligned} \text{Gradient} &= \frac{14-4}{5-0} \\ &= 2 \end{aligned} \quad \text{[B1]}$$

Answer (c) [1]

(d) Explain what the gradient means.

It means the cost increases at \$2 per km OR the cost per km

OR rate of change of cost with distance [B1] [1]

13

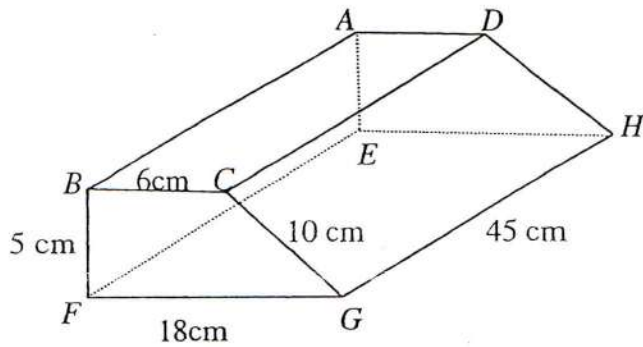

The diagram represents a prism. The faces of $ABCD$ and $EFGH$ are horizontal.

The faces $ABFE$, $BCGF$ and $ADHE$ are vertical.

$BC = AD = 6$ cm, $CG = DH = 10$ cm, $BF = AE = 5$ cm, $FG = EH = 18$ cm and

$GH = FE = BA = CD = 45$ cm.

Calculate

- (a) the volume of the prism,

$$\text{Base area} = \frac{1}{2}(6+18)(5) \quad [\text{M1}]$$

$$= 60 \text{ cm}^2.$$

$$\text{Volume} = 60 \times 45 \quad [\text{M1}]$$

$$= 2700 \text{ cm}^3 \quad [\text{A1}]$$

Answer (a) cm^3 [3]

- (b) the total surface area of the prism.

$$\text{Surface area of end faces} = 2 \times 60 \quad [\text{M1}]$$

$$= 120 \text{ cm}^2$$

$$\text{Surface area of lateral faces} = (5+6+10+18) \times 45 \quad [\text{M1}]$$

$$= 1755 \text{ cm}^2$$

$$\text{Total surface area} = 120 + 1755$$

$$= 1875 \text{ cm}^2 \quad [\text{A1}]$$

Answer (b) cm^2 [3]

- 14 The diagram shows a cylindrical pipe of height measuring 12 cm which has an internal radius of 4.5 cm and external radius of 5 cm.

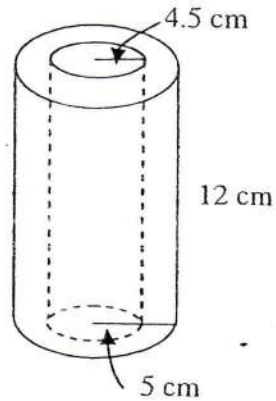

Find the total surface area of the pipe.

$$\begin{aligned} \text{Surface area of end faces} &= 2 \times \pi \times (5^2 - 4.5^2) && \text{[M1]} \\ &= 29.845 \text{ cm}^2 \end{aligned}$$

$$\begin{aligned} \text{Surface area of internal and external lateral faces} &= (2 \times \pi \times 4.5 \times 12) + (2 \times \pi \times 5 \times 12) && \text{[M1]} \\ &= 716.28 \text{ cm}^2 \end{aligned}$$

$$\begin{aligned} \text{Total surface area} &= 29.845 + 716.28 \\ &= 746.125 \\ &= 746 \text{ cm}^2 && \text{[A1]} \end{aligned}$$

Answer..... cm² [3]

End of Paper



BEATTYSECONDARY SCHOOL
END-OF-YEAREXAMINATION 2014

SUBJECT : Mathematics

LEVEL : Sec 1Express

PAPER :2

DURATION : 1 hour 30 minutes

SETTER : Ms Yuen Shu Yan

DATE :10October 2014

CLASS :	NAME :	REG NO :
---------	--------	----------

.....
READ THESE INSTRUCTIONS FIRST

Write your name, class and index number in the spaces on the top of this page.

Write in dark blue or black pen.

You may use a pencil for any diagrams or graphs.

Do not use staples, paper clips, highlighters, glue or correction fluid.

Answer **all** questions.

If working is needed for any question, it must be shown with the answer.

Omission of essential working will result in loss of marks.

You are expected to use a scientific calculator to evaluate explicit numerical expressions.

If the degree of accuracy is not specified in the question, and if the answer is not exact, give the answer to

three significant figures. Give answers in degrees to one decimal place.

For π , use either your calculator value or 3.142, unless the question requires the answer in terms of π .

The number of marks is given in brackets [] at the end of each question or part question.

The total number of marks for this paper is 50.

For Examiner's Use
50

This paper consists of 4 printed pages (including this cover page)

159

[Turn over

- 1 Subtract $5a - 3b + c$ from $2b + 3a - 5c$. [2]
- 2 Michelle wishes to cover a wall of length $2^2 \times 3^3 \times 5^4$ cm and breadth $3^2 \times 5^2 \times 7^2$ cm completely with square wallpaper of the same size. Find the length of the largest possible square wallpaper that can be used. [2]
- 3 Simplify the following expressions.
- (a) $\frac{x}{5} + \frac{1-2x}{3}$ [2]
- (b) $2 - \frac{3(5y-7)}{4}$ [2]
- 4 Without using a calculator, evaluate $[5 + (-2)^3] - [24 - (-31)] \times (-2)$. [3]
- 5 Solve $\frac{6}{3-4z} = \frac{3}{-3+4z}$. [3]
- 6 Alex bought a thumbdrive for \$15. He marked up the cost price by 60%. He then sold the thumbdrive at a discount of 20% on the marked price.
- (a) Calculate the selling price of the thumbdrive. [3]
- (b) If 7% GST is applied on the selling price, calculate the selling price including GST. [2]

7

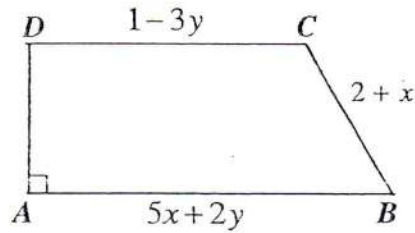

$ABCD$ is a trapezium. $AB = (5x + 2y)$ cm, $BC = (2 + x)$ cm, $CD = (1 - 3y)$ cm and the perimeter of the trapezium is $(5x - 2y + 9)$ cm.

- (a) Find the length of AD in terms of x and y . [2]
 (b) Given $x = 5$ and $y = -3$, find the area of the trapezium $ABCD$. [3]

8 In the diagram, PQ is parallel to RS . The lines VW and ZY are produced to meet at X .

Given that $\angle PVZ = 24^\circ$, $\angle RYZ = 38^\circ$ and $\angle RWV = 71^\circ$.

Stating the reasons, find the values of a and b .

[4]

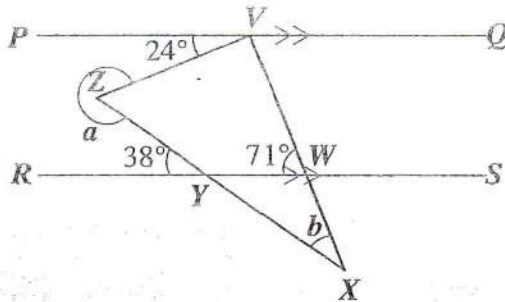

Answer the whole question on a piece of blank paper.

9 In quadrilateral $WXYZ$, $WX = 8$ cm, $WZ = 5.8$ cm, $XY = YZ = 9$ cm and $\angle XWZ = 115^\circ$.

- (a) Construct the quadrilateral $WXYZ$. [3]
 (b) The angle bisector of $\angle XYZ$ cuts WX at P . Locate, using accurate construction, the position of P . [1]
 (c) Measure and write down the length of PX . [1]

- 10 The solid below is formed from a wooden cube with its two corners cut out in the shape of a quadrant of radius 5 cm.

- (a) Find, in terms of π , the area of the cross-section. [2]
 (b) Calculate the volume of the solid. [2]
 (c) Calculate the total surface area of the solid. [3]

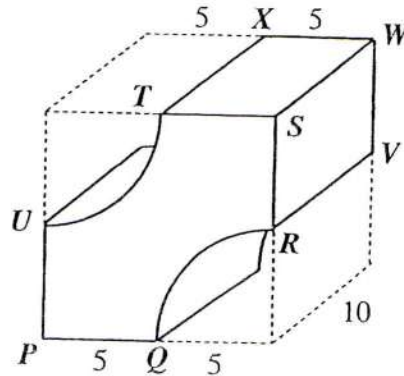

Answer the whole question on a piece of graph paper.

- 11 (a) The table below shows some values of x and y for the equation $3y = 2x - 12$.

x	0	3	6	9
y	p	-2	q	2

- Find the value of p and of q . [2]
- (b) Using the scale of 2 cm to 1 unit on both axes, draw the graph of $3y = 2x - 12$. [3]
- (c) From the graph,
- (i) state the coordinates where the line cuts the x -axis, [1]
 (ii) find the value of y when $x = 1$. [1]
- (d) Find the gradient of the line $3y = 2x - 12$. [1]
- (e) Draw and label the line $x = 7$. State the coordinates of the intersection point of $3y = 2x - 12$ and $x = 7$. [2]



BEATTYSECONDARY SCHOOL
END-OF-YEAREXAMINATION 2014

Marking Scheme

SUBJECT : Mathematics

LEVEL : Sec 1Express

PAPER : 2

DURATION : 1 hour 30 minutes

SETTER : Ms Yuen Shu Yan

DATE : 10 October 2014

1 $(2b + 3a - 5c) - (5a - 3b + c)$
 $= 2b + 3a - 5c - 5a + 3b - c$... [M1]
 $= -2a + 5b - 6c$... [A1]

2 HCF $= 3^2 \times 5^2$... [M1]
 $= 225$

\therefore length of the largest possible square wallpaper = 225 cm. ... [A1]

3 (a) $\frac{x}{5} + \frac{1-2x}{3} = \frac{3x+5(1-2x)}{15}$
 $= \frac{3x+5-10x}{15}$... [M1]
 $= \frac{5-7x}{15}$... [A1]

(b) $2 - \frac{3(5y-7)}{4} = \frac{8-15y+21}{4}$... [M1]
 $= \frac{29-15y}{4}$... [A1]

4 $[5 + (-2)^3] - [24 - 31] \times (-2) = [5 + (-8)] - (24 + 31) \times (-2)$... [M2]
 $= (-3) - (-110)$
 $= 107$... [A1]

$$5 \quad \frac{6}{3-4z} = \frac{3}{-3+4z}$$

$$6(-3 + 4z) = 3(3 - 4z) \quad \dots \text{ [M1]}$$

$$-18 + 24z = 9 - 12z$$

$$36z = 27 \quad \dots \text{ [M1]}$$

$$z = \frac{27}{36} = \frac{3}{4} \quad \dots \text{ [A1]}$$

$$6 \quad (a) \quad \text{Marked price of thumbdrive} = \frac{160}{100} \times 15 \quad \dots \text{ [M1]}$$

$$= \$24$$

$$\text{Selling price of thumbdrive} = \frac{80}{100} \times 24 \quad \dots \text{ [M1]}$$

$$= \$19.20 \quad \dots \text{ [A1]}$$

$$(b) \quad \text{Selling price including GST} = \frac{107}{100} \times 19.20 \quad \dots \text{ [M1]}$$

$$= \$20.54 \text{ (to 2 d.p.)} \quad \dots \text{ [A1]}$$

$$7 \quad (a) \quad AD = (5x - 2y + 9) - (5x + 2y) - (2 + x) - (1 - 3y) \quad \dots \text{ [M1]}$$

$$= 5x - 2y + 9 - 5x - 2y - 2 - x - 1 + 3y$$

$$= -x - y + 6 \text{ cm} \quad \dots \text{ [A1]}$$

$$(b) \quad \text{When } x = 5, y = -3,$$

$$AD = -5 - (-3) + 6 = 4 \text{ cm}$$

$$CD = 1 - 3(-3) = 10 \text{ cm}$$

$$AB = 5(5) + 2(-3) = 19 \text{ cm}$$

} ... Substitution of values [M1]

$$\therefore \text{Area of trapezium} = \frac{1}{2}(4)(10 + 19) \quad \dots \text{ [M1]}$$

$$= 58 \text{ cm}^2 \quad \dots \text{ [A1]}$$

8 (Addition of one parallel line that passes through Z)

Acute $\angle VZY = 24^\circ + 38^\circ = 62^\circ$ (alt. \angle s) ... [M1]

$\angle a = 360^\circ - 62^\circ = \underline{298^\circ}$ (\angle s at a point) ... [A1]

$\angle QVW = 71^\circ$ (alt. \angle s)

$\angle ZVX = 180^\circ - (71^\circ + 24^\circ) = 85^\circ$ (\angle s on a straight line) ... [M1]

$\angle b = 180^\circ - (62^\circ + 85^\circ) = \underline{33^\circ}$ (\angle sum of Δ) ... [A1]

9

(c) $PX = 6.6 \text{ cm}$ (B1)

Accept $\pm 0.1 \text{ cm}$

(a)

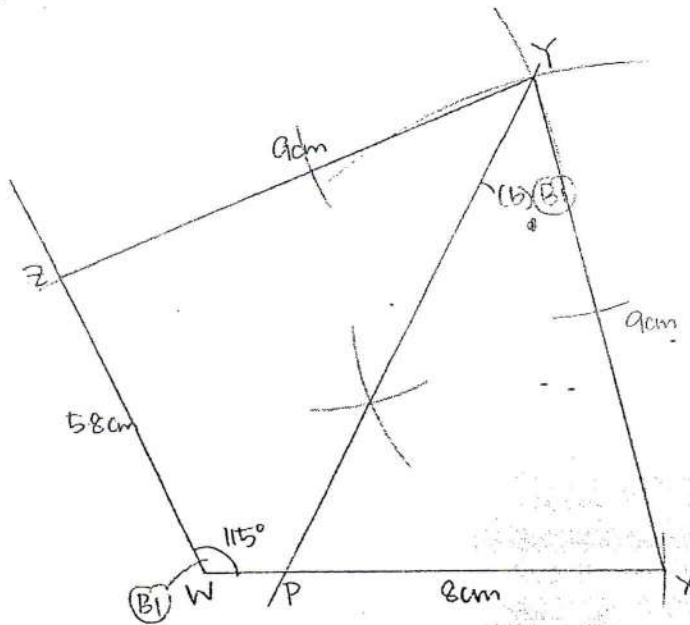

$WZ \text{ \& } WX - (B1)$
 $YZ = XZ = 9 \text{ cm} - (B1)$

10 (a) Area of cross-section = $(10 \times 10) - \frac{1}{2}[\pi(5)^2]$... [M1]

= $100 - 12.5\pi \text{ cm}^2$... [A1]

(b) Volume of wood = $(100 - 12.5\pi) \times 10$... [M1]

= 607 cm^3 (to 3 sig. fig) ... [A1]

171

(c) Perimeter of figure = $\frac{1}{2} [2\pi(5)] + 4(5)$
 $= 5\pi + 20 \text{ cm}$
 \therefore Total surface area = $(5\pi + 20) \times 10 + 2(100 - 12.5\pi)$... [M2]
 $= 479 \text{ cm}^2$ (to 3 sig. fig.) ... [A1]

11

