

ANGLO-CHINESE SCHOOL  
(JUNIOR)



CONTINUAL ASSESSMENT 1 (2013)  
PRIMARY 3

SCIENCE

BOOKLET A

WEDNESDAY

27 FEBRUARY 2013

1 HOUR

Name : \_\_\_\_\_ (     )

Class : P3 \_\_\_\_\_

**INSTRUCTIONS TO PUPILS**

**DO NOT TURN OVER THE PAGES UNTIL YOU ARE TOLD TO DO SO**

Follow all instructions carefully.

There are 15 questions in this booklet.

Answer **ALL** questions.

**INFORMATION FOR PUPILS**

The total marks for this booklet is 30.

The total time for Booklets A and B is 1 hour.







**This question paper consists of 8 printed pages. (Inclusive of cover page)**

**Section A (30 marks)**

For each question from 1 to 15, four options are given. One of them is the correct answer.

Choose the correct option (1, 2, 3 or 4) and shade the correct oval on the Optical Answer Sheet (OAS).

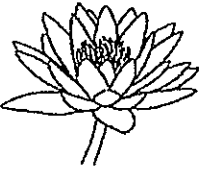
1 Some plants have been classified in the following groups:

| Group A   |         | Group B   |         |
|---|---------|---|---------|
|    | Plant A |    | Plant D |
|   | Plant B |   | Plant F |
|  | Plant C |  | Plant G |

Which plant was classified wrongly?

- (1) A
- (2) B
- (3) F
- (4) G

- 2 Jack has some marbles as shown below.

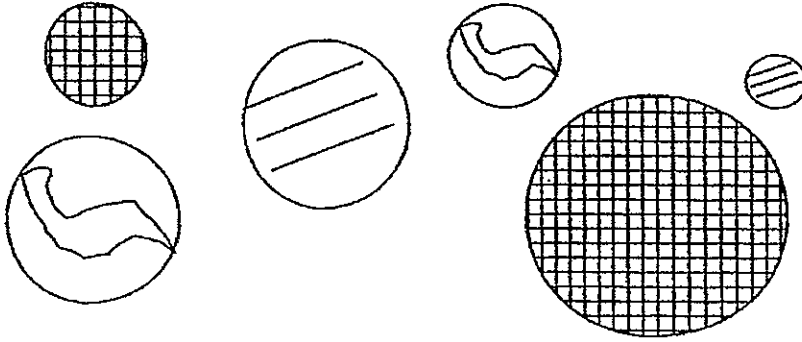

He wants to put the marbles into three groups. Which of the following properties can be used to classify them?

- A By size
  - B By shape
  - C By pattern
- (1) C only
- (2) A and B only
- (3) A and C only
- (4) B and C only
3. There are many books in the school library. Mark can search for the books he needs based on its \_\_\_\_\_.
- A title
  - B size
  - C author
  - D colour
- (1) A and B only
- (2) A and C only
- (3) B and C only
- (4) B and D only

4 Alan saw a snail crawling on the ground. He touched it gently and observed that the snail moved into its shell immediately. What does this tell you about living things?

- (1) Living things grow.
- (2) Living things reproduce.
- (3) Living things respond to changes.
- (4) Living things need air, food and water.

5 Study the classification table below.

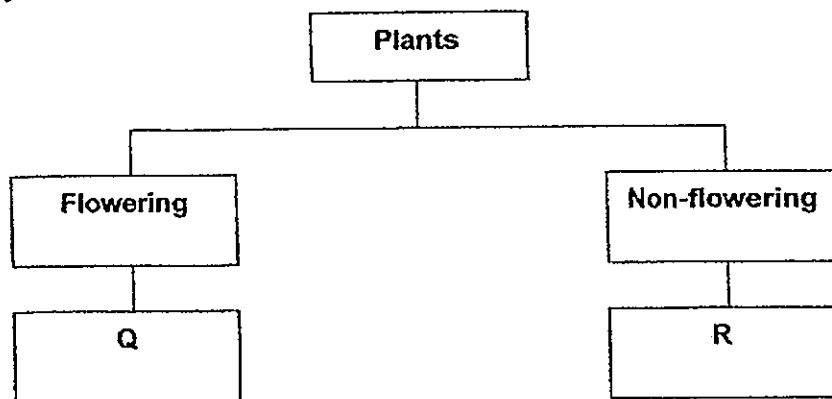

Which of the following can be Q and R?

|     | Q         | R           |
|-----|-----------|-------------|
| (1) | Ixora     | Ladder fern |
| (2) | Allamanda | Ixora       |
| (3) | Moss      | Ladder fern |
| (4) | Moss      | Allamanda   |

6 A car is a non-living thing because it \_\_\_\_\_.

- (1) cannot grow
- (2) cannot move
- (3) needs air to survive
- (4) needs water to survive

7 Study the classification table below.

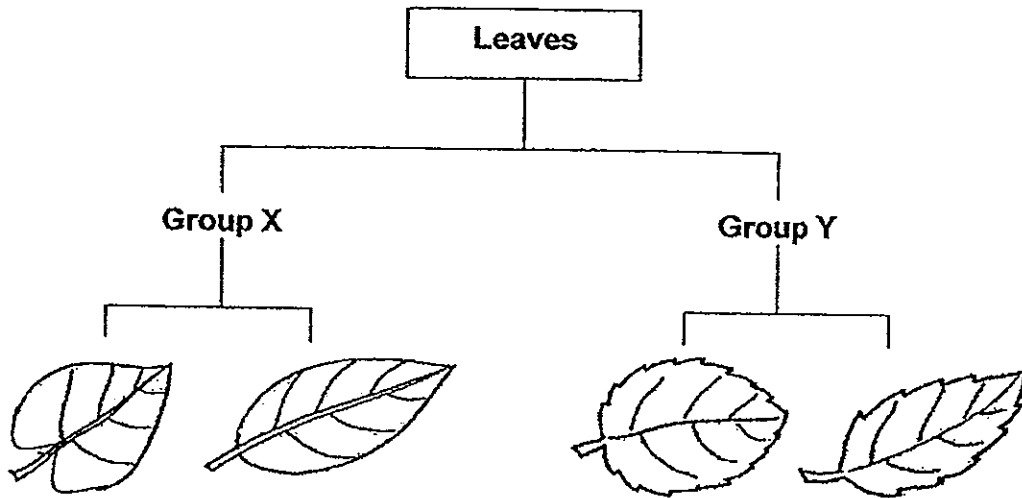

Which one of the following best describes Group X?

- (1) Oval-shaped
- (2) Heart-shaped
- (3) Smooth-edged
- (4) Jagged-edged

8 Gavin classified the stationery found in his classroom based on their uses as shown in the diagram below.

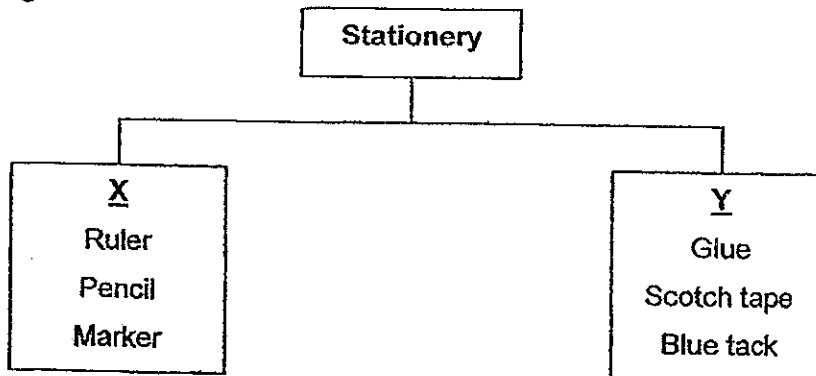

Which object has been grouped wrongly?

- (1) glue
- (2) ruler
- (3) marker
- (4) scotch tape

9 Bernard drew the following classification chart.

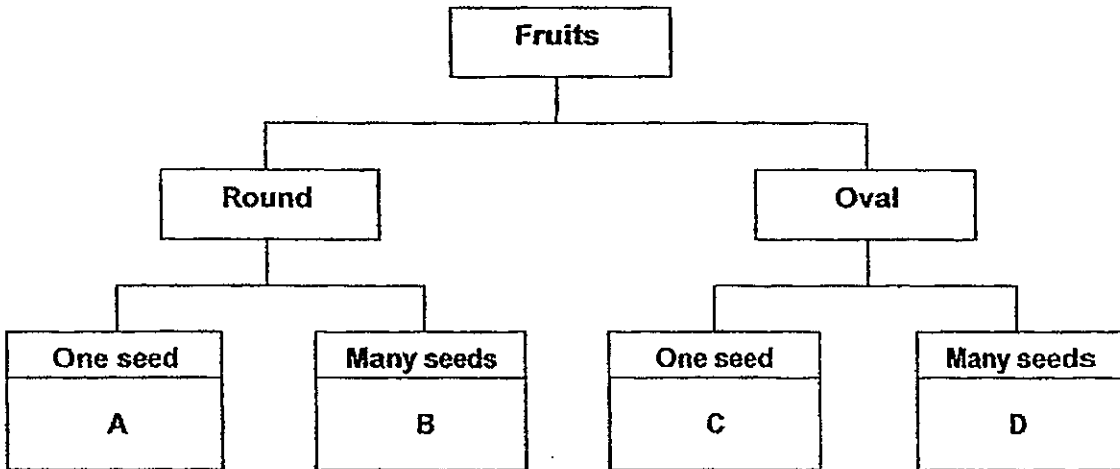

Which group should he classify the fruit below?



- (1) A
- (2) B
- (3) C
- (4) D

10 Alex placed 100g of food and 100ml of water in three containers, X, Y and Z. He recorded the amount of food and water left at the end of a week.

| Container | Amount of water (ml) | Amount of food (g) |
|-----------|----------------------|--------------------|
| X         | 43                   | 33                 |
| Y         | 28                   | 38                 |
| Z         | 100                  | 100                |

Based on the above information, which containers contain a living thing?

- (1) X and Y only
- (2) X and Z only
- (3) Y and Z only
- (4) X, Y and Z

11 Tom picked up a dry leaf. His teacher said that it was a non-living thing because it \_\_\_\_\_.

- A can move on its own
- B cannot grow anymore
- C cannot reproduce anymore

- (1) A and B only
- (2) A and C only
- (3) B and C only
- (4) A, B and C

12 Mrs Lee has some flowering plants in her garden. She is able to tell that the plants are flowering because they have \_\_\_\_\_.

- (1) fruits
- (2) woody stems
- (3) spores on their leaves
- (4) different leaf shapes and veins

13 The picture below shows Plant A which grows on a tree.



Plant A does not produce seeds. It should be classified as a \_\_\_(P)\_\_\_ plant which grows on/in \_\_\_(Q)\_\_\_.

|     | (P)           | (Q)   |
|-----|---------------|-------|
| (1) | flowering     | land  |
| (2) | flowering     | water |
| (3) | non-flowering | land  |
| (4) | non-flowering | water |

- 14 Mary put a plant into a box as shown in Diagram A and watered it daily. After a week, she observes some changes in the plant as shown in Diagram B.

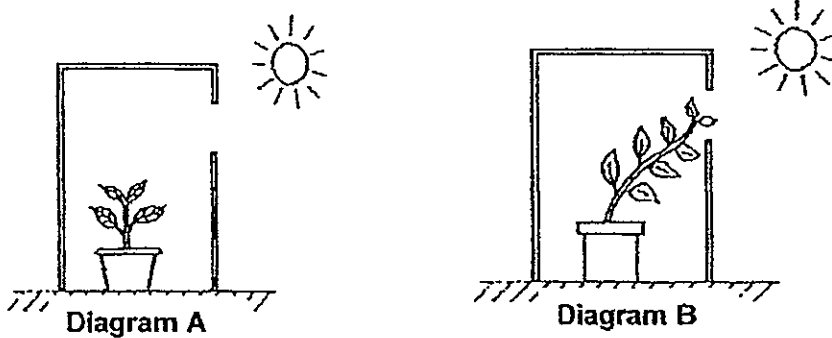

She carried out this experiment to show that plants \_\_\_\_\_.

- (1) can reproduce
  - (2) only need water to grow
  - (3) grow and respond to changes
  - (4) can only grow when placed in a box
- 15 The diagram below shows two leaves, X and Y.

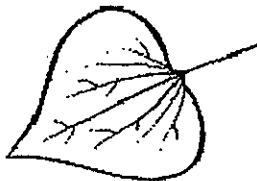

Leaf X



Leaf Y

Leaf X and Leaf Y differ in their \_\_\_\_\_.

- A size
  - B shape
  - C vein pattern
  - D type of edge
- (1) A and B
  - (2) C and D
  - (3) A, B and D
  - (4) A, B, C and D



ANGLO-CHINESE SCHOOL  
(JUNIOR)



CONTINUAL ASSESSMENT 1 (2013)  
PRIMARY 3

SCIENCE

BOOKLET B

WEDNESDAY

27 FEBRUARY 2013

1 HOUR

Name : \_\_\_\_\_ ( )

Class : P3 \_\_\_\_\_

**INSTRUCTIONS TO PUPILS**

**DO NOT TURN OVER THE PAGES UNTIL YOU ARE TOLD TO DO SO**

Follow all instructions carefully.

There are 7 questions in this booklet.

Answer **ALL** questions.

**INFORMATION FOR PUPILS**

The number of marks is given in brackets [ ] at the end of each question or part question.

The total marks for this booklet is 20.

The total time for Booklets A and B is 1 hour.

**This question paper consists of 6 printed pages. (Inclusive of cover page)**

|                           |      |
|---------------------------|------|
| BOOKLET A                 | 30   |
| BOOKLET B                 | / 20 |
| TOTAL                     | / 50 |
| Parent's signature/ Date: |      |

**Section B (20 marks)**

Write your answers to questions 16 to 22 in this booklet.  
Fill the blanks with the correct answers.

16 The diagram below shows two objects, A and B.

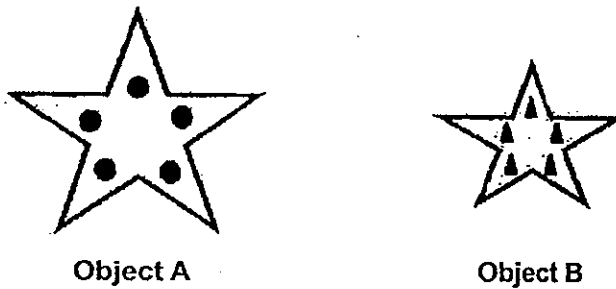

(a) State one similarity between Object A and Object B. [1]

---

(b) State one difference between Object A and Object B. [1]

---

17 The table below shows the mass of a baby rabbit over 4 weeks.

| Mass of rabbit at the end of: |           |        |           |
|-------------------------------|-----------|--------|-----------|
| Week 3                        | Week 4    | Week 5 | Week 6    |
| 350 grams                     | 400 grams |        | 500 grams |

(a) What could the mass of the baby rabbit be at the end of week 5? [1]

---

(b) What does the baby rabbit need for it to survive? [1]

---

(c) Based on the above information, which characteristic of living things does the baby rabbit show? [1]

---

|  |
|--|
|  |
|--|

The diagram below shows four things.

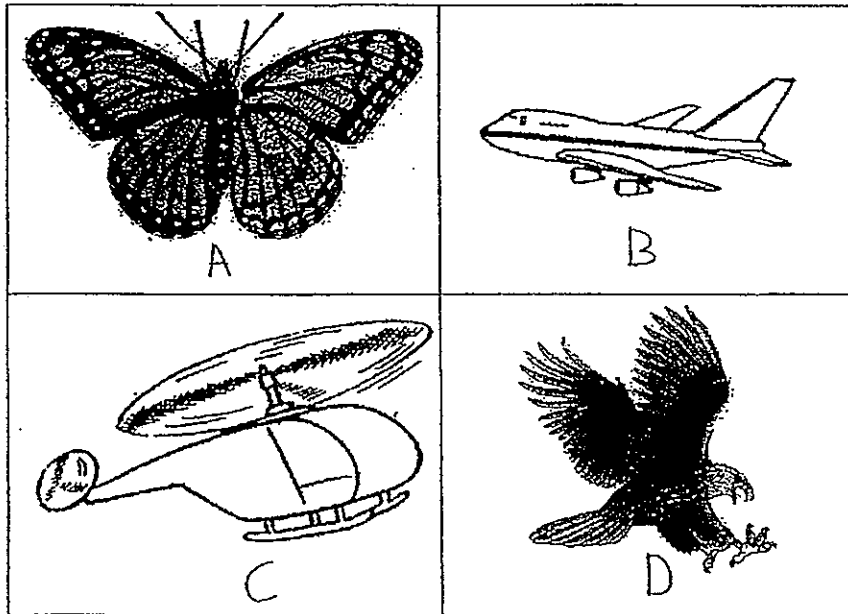

(a) State one way in which all the things above are similar. (Do not compare size) [1]

---

(b) Classify the objects using the table below. [2]

| Living | Non-Living |
|--------|------------|
| _____  | _____      |
| _____  | _____      |

|  |
|--|
|  |
|--|

19 Jimmy made some cards with holes in them as

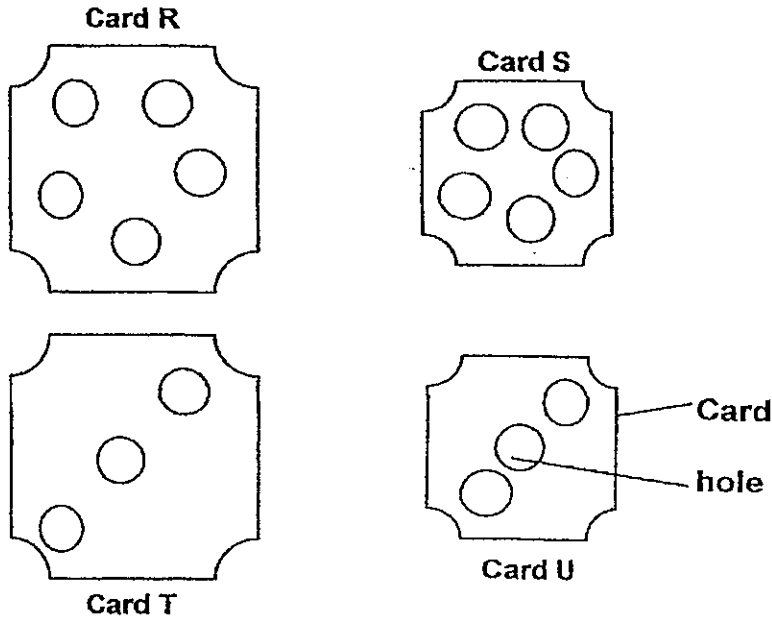

(a) State 2 ways in which Jimmy can classify the cards. [2]

Method 1 : \_\_\_\_\_

Method 2 : \_\_\_\_\_

(b) Jimmy later coloured the cards as shown below.

| Card | Colour |
|------|--------|
| R    | Green  |
| S    | Blue   |
| T    | Blue   |
| U    | Green  |

Fill in the classification table with suitable sub-headings. [1]

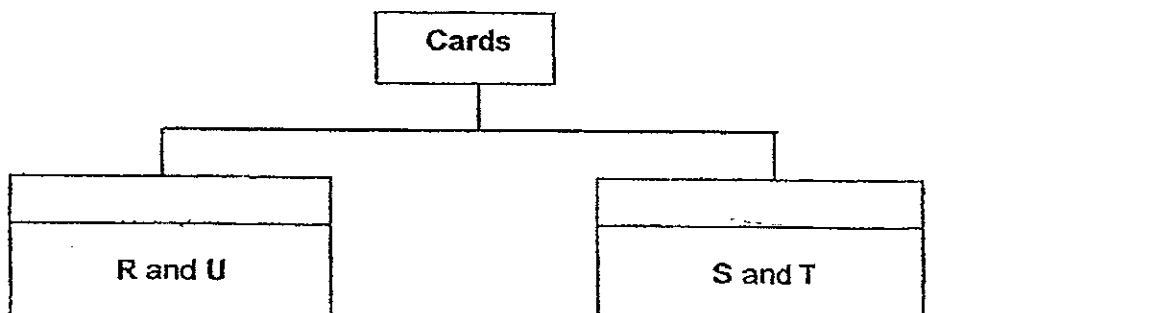

|  |
|--|
|  |
|--|

Study the classification chart below.

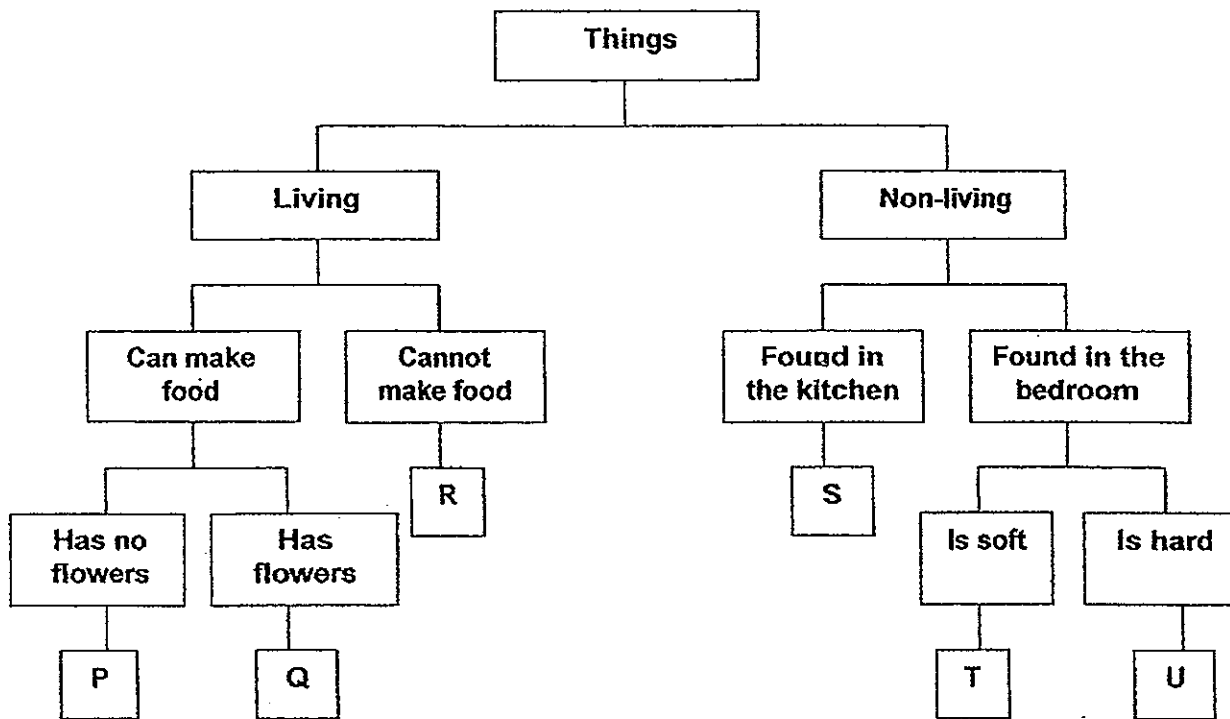

(a) State all the characteristics of Thing Q. [2]

---

(b) What is the difference between Things S and U? [1]

---

(c) What is the similarity between Thing P and R? [1]

---

|  |
|--|
|  |
|--|

21 Ali set up an aquarium in his house as shown below. He fed the fish with food daily.

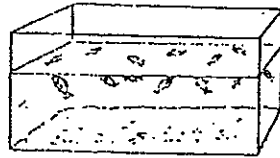

(a) Ali noticed that the fish were often seen near the surface of the water. State a reason for this and explain your reason. [2]

---



---

(b) What can Ali do to solve the problem? [1]

---

22 Jack had two similar pots of plants, P and Q. He placed them at two different places. He watered them everyday with the same amount of water. The diagram below shows how the plants look like at the end of a week.

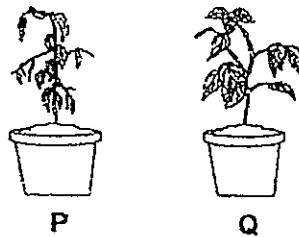

He noticed that the leaves of plant P have turned yellow and its stem is thin and weak. However, the leaves of plant Q are green and its stem is thick and strong.

(a) Where did Jack place the plants? Write the letters 'P' and 'Q' to represent Plant P and Plant Q respectively in the correct boxes. [1]

| Closed Cupboard | Garden |
|-----------------|--------|
|                 |        |

(b) Based on the result of Jack's observation of the plants after a week, suggest what the plants need to continue to grow healthily. [1]

---

|  |
|--|
|  |
|--|

# ANSWER SHEET

## EXAM PAPER 2013

SCHOOL : ANGLO-CHINESE SCHOOL (JUNIOR)

LEVEL : PRIMARY 3

SUBJECT : SCIENCE

TERM : CA1

### BOOKLET A

|    |    |    |    |    |    |    |    |    |     |     |     |     |     |     |
|----|----|----|----|----|----|----|----|----|-----|-----|-----|-----|-----|-----|
| Q1 | Q2 | Q3 | Q4 | Q5 | Q6 | Q7 | Q8 | Q9 | Q10 | Q11 | Q12 | Q13 | Q14 | Q15 |
| 4  | 3  | 2  | 3  | 1  | 1  | 3  | 2  | 4  | 1   | 3   | 1   | 3   | 3   | 4   |

### BOOKLET B

Q16

(a) They both have the same number of shapes inside.

(b) Object A is bigger while object B is smaller.

Q17

(a) The mass of the baby rabbit could be 450 grams.

(b) The baby rabbit needs air, water and food to survive.

(c) Living things can grow.

Q18

(a) They all can fly.

(b)

| Living | Non-Living |
|--------|------------|
| A      | C          |
| D      | B          |

Q19

(a) Method 1: Classify by size.

Method 2: Classify by numbers of holes.

(b)

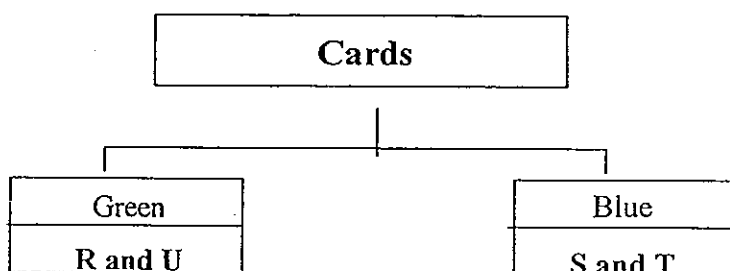

Q20

- (a) Thing Q can make food and has flowers
- (b) Thing S is found in the kitchen while thing U is found in the bedroom.
- (c) They both do not have flowers.

Q21

- (a) They needed air from above the surface to survive.
- (b) Ali can install an air pump.

Q22

(a)

| <b>Closed Cupboard</b> | <b>Garden</b> |
|------------------------|---------------|
| P                      | Q             |

- (b) The plants need sunlight to grow healthily.





HENRY PARK PRIMARY SCHOOL  
PRIMARY 3 SCIENCE 2013  
TEST 1

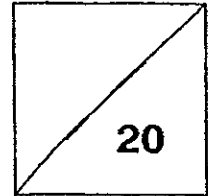

Duration of Paper: 45 mins

Name: \_\_\_\_\_

Class: Pr 3 \_\_\_\_\_

Parent's Signature: \_\_\_\_\_

**SECTION A : Multiple Choice Questions ( 5 x 2 = 10 marks )**

For each question from 1 to 5, four options are given. One of them is the correct answer. Make your choice (1, 2, 3 or 4) and write its number in the bracket provided.

1. The picture below shows a trampoline which gymnasts use to practice their jumping. Parts A and B are made from different materials.

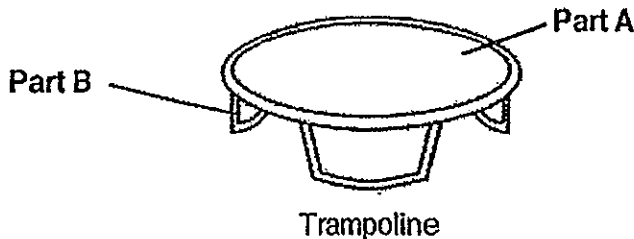

Which one of the following materials and their properties in the table below are most suitable to be used to make Parts A and B?

|     | Part A   |            | Part B   |            |
|-----|----------|------------|----------|------------|
|     | Material | Properties | Material | Properties |
| (1) | Metal    | Hard       | Rubber   | Flexible   |
| (2) | Glass    | Strong     | Wood     | Can float  |
| (3) | Rubber   | Can float  | Glass    | Hard       |
| (4) | Fabric   | Flexible   | Metal    | Strong     |

( )

2. The flow chart below shows the characteristics of objects A, B, C and D.

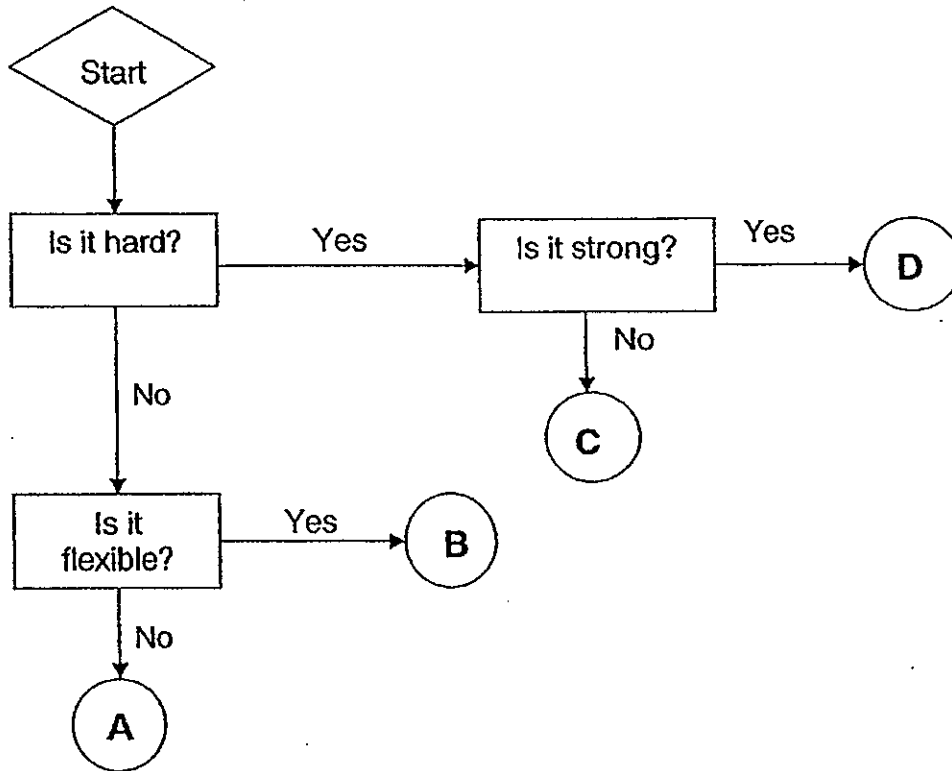

Based on the flowchart above, which one of the following best represents metal?

- (1) A
- (2) B
- (3) C
- (4) D

( )

3. Look at the picture of the farmer's axe below. It is made of materials that are represented by Part X and Y.



Farmer's Axe

The axe is likely made of \_\_\_\_\_ and \_\_\_\_\_.

|     | Part X  | Part Y |
|-----|---------|--------|
| (1) | Wood    | Metal  |
| (2) | Metal   | Wood   |
| (3) | Plastic | Glass  |
| (4) | Rubber  | Wood   |

( )

4. John conducted several tests on materials P, Q, R, S. The results are shown in the table below.

| Materials               | P   | Q   | R   | S   |
|-------------------------|-----|-----|-----|-----|
| It is flexible.         | Yes | Yes | No  | No  |
| It breaks when dropped. | No  | No  | No  | Yes |
| It is strong.           | Yes | No  | Yes | Yes |

Which material would you use to make a key?

- (1) P
- (2) Q
- (3) R
- (4) S

( )

5. Kellan wanted to test the **strength** of four different sheets of materials, **W, X, Y** and **Z**. Each sheet is of the same size and thickness. He placed weights on the materials as shown below and noted the least number of weights needed to make the material break.

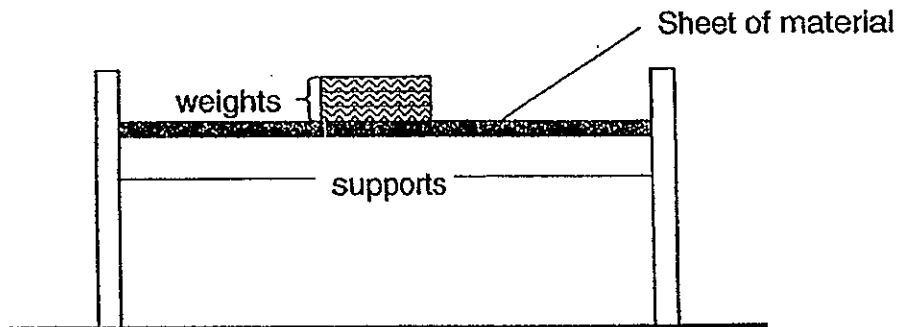

Which of the following must he follow to make sure that his experiment is a fair one?

- A: He must use weights of different sizes.
- B: He must use weights of different materials.
- C: He must keep the heights of the supports the same.
- D: He must use the supports that are made from the same material.

- (1) A only
- (2) A and B only
- (3) C and D only
- (4) B, C and D only.

(     )

**SECTION B: Structured Questions ( 2X2= 4 marks )**

For each question from 6 to 7, write the answers in the spaces provided.

6. The flow chart below shows the characteristics of materials S, T, U and V.

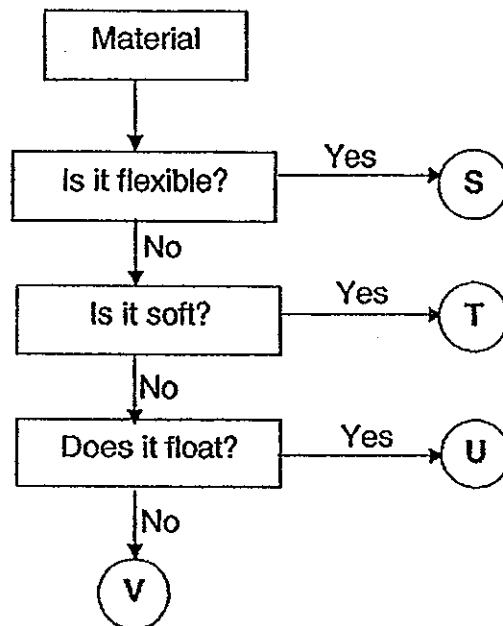

Dylan wants to make a toy boat for his brother to play in the pond.

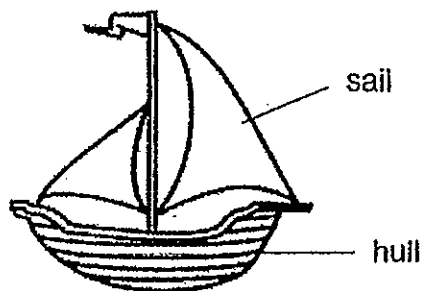

Based on the flow chart above, which material S, T, U or V should the following parts be made of? (2m)

(a) Sail : \_\_\_\_\_

(b) Hull : \_\_\_\_\_

7. Leo had 3 materials, **A**, **B** and **C**, of the same size and thickness. He wanted to find out which material is the hardest. He used 3 different types of nails, **Nail 1**, **2** and **3** to scratch the 3 different materials.

His experimental set-up is shown in the diagrams below.

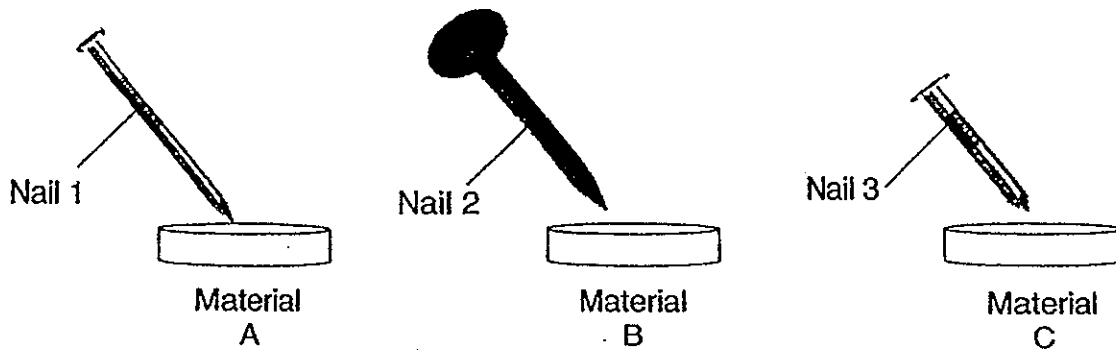

His teacher commented that his experiment was **unfair**.

Which of the statements in the table below explains why his teacher is right?  
Put a (✓) tick against the correct statement. (2m)

|     | Statement  | Tick (✓) |
|-----|--|----------|
| (a) | Leo used 3 different nails to scratch the 3 different materials.     |          |
| (b) | Leo used 3 different materials to find out which one is the hardest. |          |
| (c) | Leo should use only one nail to scratch all the 3 materials.         |          |
| (d) | Leo should use the 3 materials to scratch the 3 nails.               |          |

**SECTION C: Open- Ended Questions (6 marks)**

8. Ivy conducted several tests on materials **K, L, M** and **N** and recorded the results as shown in the table below.

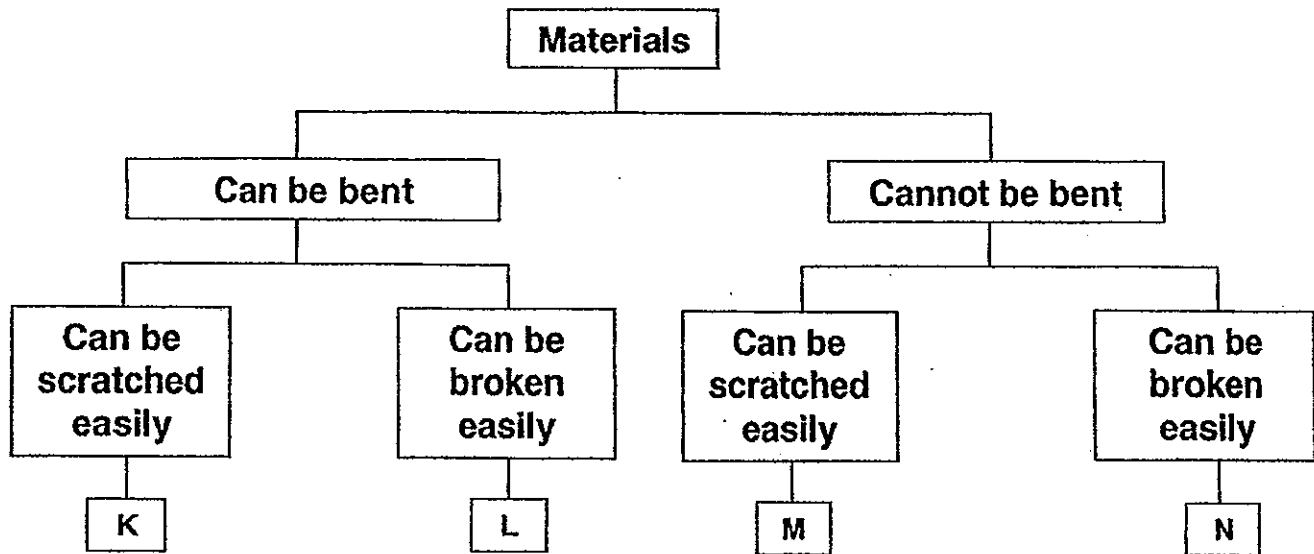

(a) Which material, **K, L, M** or **N** represents the materials below? (1m)

Rubber : Material \_\_\_\_\_

Glass : Material \_\_\_\_\_

(b) Based on the information given in the above table, state one similarity and difference between **Material L** and **Material N**. (2m)

Similarity: \_\_\_\_\_  
\_\_\_\_\_

Difference: \_\_\_\_\_  
\_\_\_\_\_

9. Joel set up the experiment below to find out whether the objects made of 4 different materials will float or sink in water.

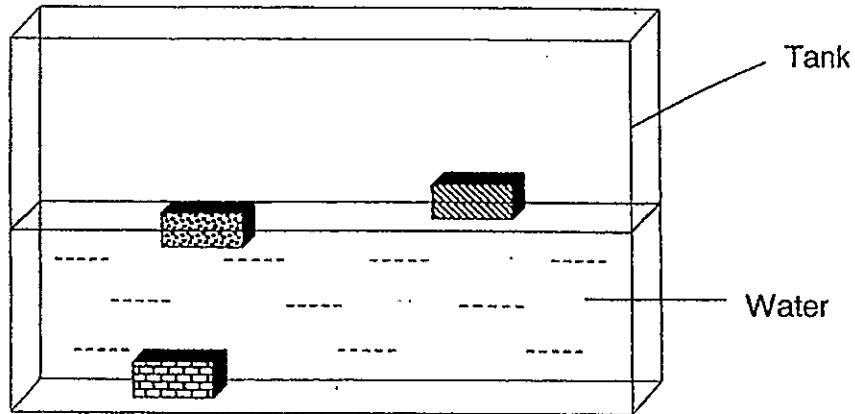

- (a) Joel needs a 4th object to compare with the other three. Which one of the 3 objects below should he choose for the experiment? (1m)



Object F



Object G



Object H

Joel should choose Object \_\_\_\_\_

- (b) Explain your answer in (a). (1m)

---



---

- (c) Which other variable he should **keep the same** to conduct a fair test? **CIRCLE** the correct variable from the box below. (1m)

|                     |                        |
|---------------------|------------------------|
| Material of objects | Weights of the objects |
|---------------------|------------------------|

END OF PAPER

Setters: Mdm Faaizah Parwin  
Mdm Fathlon Tawfik



# ANSWER SHEET

**EXAM PAPER 2013**

**SCHOOL : HENRY PARK PRIMARY SCHOOL**

**SUBJECT : PRIMARY 3 SCIENCE**

**TERM : CA1**

---

| Q1 | Q2 | Q3 | Q4 | Q5 |
|----|----|----|----|----|
| 4  | 4  | 2  | 3  | 3  |

Section B

Q6

a) Sail: S

b) Hull: U

Q7)

|     | Statement   | Tick |
|-----|---|------|
| (a) | Leo used 3 different nails to scratch 3 different materials         | √    |
| (b) | Leo used 3 different materials to find out which one is the hardest |      |
| (c) | Leo should use only one nail to scratch all the materials           | √    |
| (d) | Leo should use the 3 materials to scratch the 3 nails               |      |

Q8

a) Rubber: Material K

Glass: Material N

b) Similarity: Both materials L and N can be broken easily

Difference: Material L can be bent while material N cannot be bent

Q9

a) Object G

b) It is the same size

c) Weight of the objects



# METHODIST GIRLS' SCHOOL

Founded in 1887

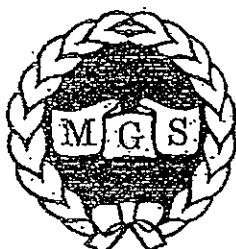

## CONTINUAL ASSESSMENT 2013 PRIMARY 3 SCIENCE

Total Time for Sections A and B: 1 hour

### INSTRUCTIONS TO CANDIDATES

Do not turn over this page until you are told to do so.

Follow all instructions carefully.

Answer all questions.

Write your answers in this booklet.

Name: \_\_\_\_\_ ( )

Class: Primary 3. \_\_\_\_\_

Date: 7 March 2013

|                  |             |
|------------------|-------------|
| <b>Section A</b> | <b>/ 30</b> |
| <b>Section B</b> | <b>/ 20</b> |
| <b>TOTAL</b>     | <b>/ 50</b> |

This booklet consists of 13 printed pages including this page.

## SECTION A : 30 marks

For each question from 1 to 15, four options are given, one of them is the correct answer. Make your choice (1, 2, 3 or 4). Shade the correct oval (1, 2, 3 or 4) on the Optical Answer Sheet.

1. Joseph grouped some things according to the classification chart shown below.

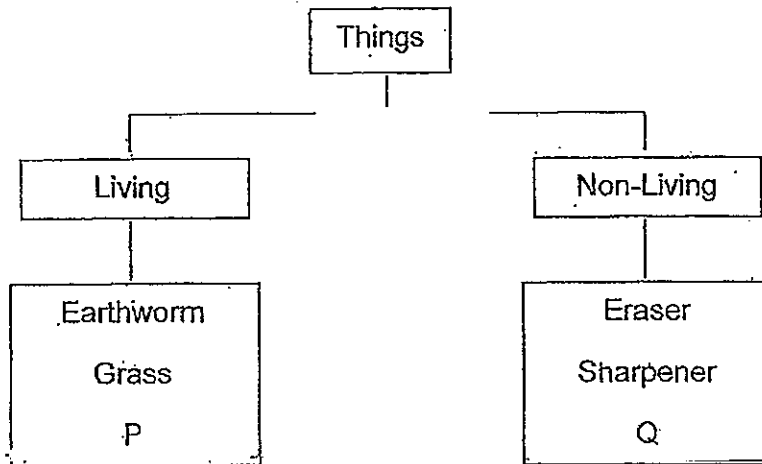

What could P and Q be?

|     | P    | Q     |
|-----|------|-------|
| (1) | Soil | Stone |
| (2) | Fly  | Coral |
| (3) | Seed | Plate |
| (4) | Bag  | Ant   |

2. Which animal is wrongly matched to its group?

|     | Animal Group | Animal     |
|-----|--------------|------------|
| (1) | Bird         | Kingfisher |
| (2) | Insect       | Ladybird   |
| (3) | Fish         | Mudskipper |
| (4) | Mammal       | Shark      |

(Go on to the next page)

3. Compare the two organisms below.



Mushroom



Fern

Which of the following statements is **incorrect**?

- (1) Both reproduce by spores
  - (2) Both do not produce flowers
  - (3) Both cannot make their own food.
  - (4) Both cannot move from one place to another on their own.
4. Which of the following are **incorrectly** paired?

|     | Item       | Living thing from which it comes |
|-----|------------|----------------------------------|
| (1) | Silk       | Silkworm                         |
| (2) | Tyre       | Rubber tree                      |
| (3) | Charcoal   | Tree                             |
| (4) | Candle wax | Plant                            |

5. Sarah planted some sunflower seeds for her Science project. After a month, she observed healthy young sunflower plants growing but she did not see any sunflower. Why?

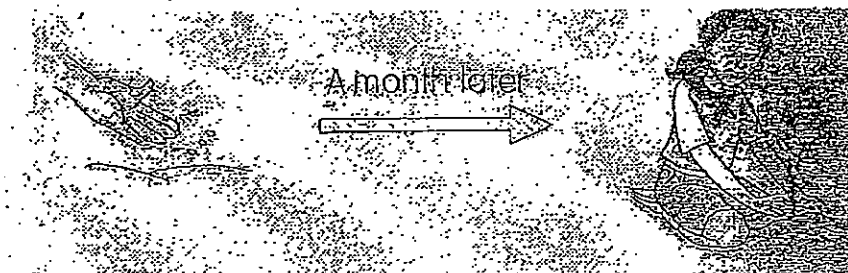

- (1) The plant only bears flowers after it matures.
- (2) Sarah used the wrong type of sunflower seeds.
- (3) The soil used was not suitable for sunflower plants.
- (4) It is a male plant, so it will not produce any flowers.

(Go on to the next page)

6. Which of these birds cannot fly?

A.



B.



C.



D.



- (1) B only
- (2) A and C only
- (3) B and D only
- (4) A, B and D only

7. What do these items have in common?



disposable chopsticks

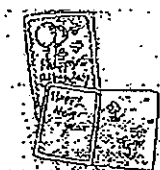

greeting cards



wooden door



mahogany table



shoebox



textbook

- A: They come from trees.
- B: They need air to survive
- C: They are non-living things.
- D: They are made of things that were never alive

- (1) A and B
- (2) A and C
- (3) C and D
- (4) A, B and D

(Go on to the next page)

8. Plants are important to us because different plants can provide us with \_\_\_\_\_.

- A: Food
- B: Shade
- C: Medicine
- D: Materials

- (1) A and B
- (2) B and C
- (3) A, B and D
- (4) A, B, C and D

Study the flow chart below and answer questions 9 and 10.

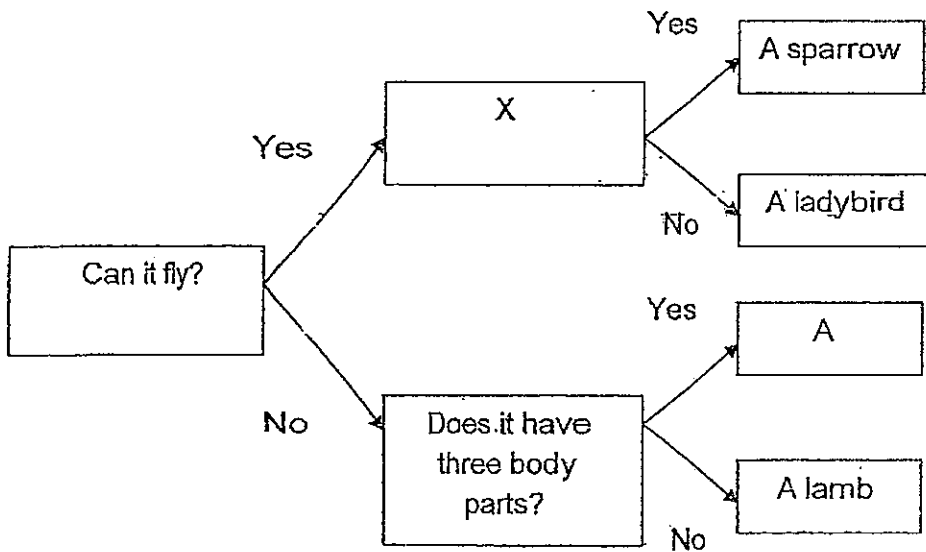

9. Which of the following questions does X represent?

- (1) Does it eat plants?
- (2) Does it have feathers?
- (3) Does it have two legs?
- (4) Does it have two wings?

10. Animal A is a \_\_\_\_\_.

- (1) Spider
- (2) Butterfly
- (3) Scorpion
- (4) Silverfish

(Go on to the next page)

11. Divers carry a tank of oxygen when they go underwater. This is because \_\_\_\_\_



- (1) the water is too cold.
- (2) there is no oxygen in water.
- (3) humans cannot breathe in water.
- (4) there is too much salt in the water.

2. A teacher placed a stick in the middle of a field. Four students were asked to observe the shadow of the stick and to state their observation. Which student is correct?

Steven: A shadow is a living thing as it can move and grow in length.

Grace: A shadow is a non-living thing as it cannot reproduce.

David: A shadow is a living thing as it responds to the positions of the Sun in the sky.

Tim: A shadow is a non-living thing as its position and length depend on the Sun's position.

- (1) Tim only
- (2) Steven only
- (3) Grace and Tim
- (4) Steven and David



13. Chloe caught two different organisms which can fly. One of them is an insect. Which of the following characteristics are important in identifying that it is an insect?

- A: A head
- B: Two eyes.
- C: Two wings.
- D: Two antennae.
- E: Three body parts

- (1) A and B only
- (2) D and E only
- (3) A, B and C only
- (4) C, D and E only

14. Study the table below

| P        | Q     |
|----------|-------|
| Hibiscus | Moss  |
| Balsam   | Algae |
| A        | B     |

What could A and B be?

|     | A           | B                   |
|-----|-------------|---------------------|
| (1) | Tree Fern   | Morning Glory       |
| (2) | Rose        | Dragon's Scales     |
| (3) | Banana Tree | Durian Tree         |
| (4) | Allamanda   | Flame of the forest |

15. Study the classification below.

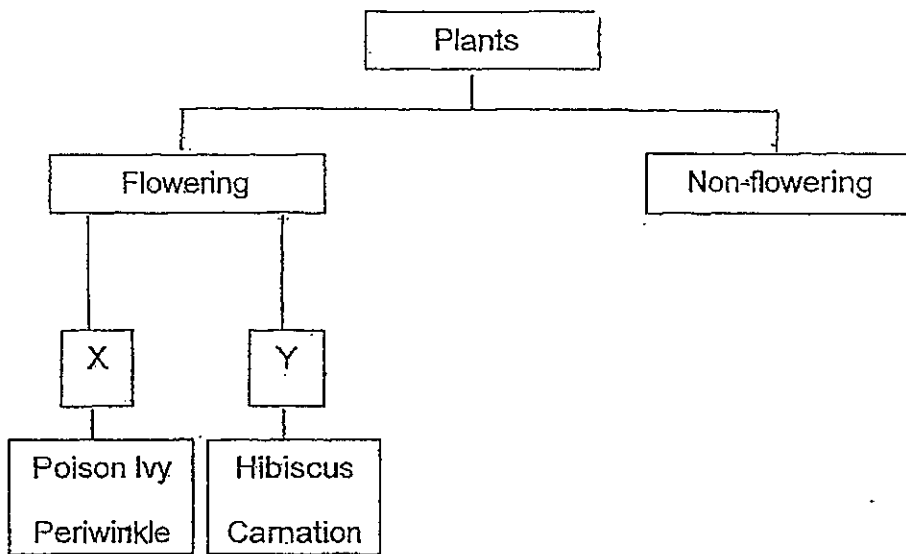

What is the most suitable heading for Y?

- (1) Edible
- (2) Grow singly
- (3) Grow on land
- (4) Non-poisonous

## SECTION B : 20 marks

For questions 16 to 23, write your answers in the spaces provided.

The number of marks available is shown in brackets [ ] at the end of each question, or part question.

16. Six animals are classified into two groups as shown in the table below.

| Group 1 | Group 2 |
|---------|---------|
| Horse   | Eagle   |
| Cow     | Seagull |
| Rabbit  | Tiger   |

a) Suggest a suitable heading for the two groups.

(i) Group 1: \_\_\_\_\_ [1]

(ii) Group 2: \_\_\_\_\_ [1]

b) Which group does a crocodile belong to? [1]

17. Jill placed a plate of sugar on the kitchen floor. After some time, ants were seen surrounding the sugar on the plate.

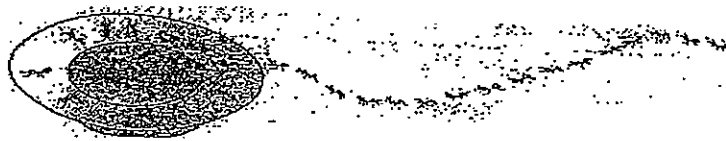

Write down the two characteristics of living things that can be observed from the above picture.

a) \_\_\_\_\_ [1]

b) \_\_\_\_\_ [1]

(Go on to the next page)

18. Study the data below. It shows the mass of a baby rabbit over a period of time.

| Age in weeks | Mass in grams |
|--------------|---------------|
| 2            | 200           |
| 3            | 300           |
| 4            | 450           |
| 5            | ?             |
| 6            | 650           |

- a) Predict the mass of the baby rabbit in week 5 from the data given in the table above.

[1]

---

- b) What is the relationship between the age of the rabbit and its mass?

[1]

---

19. A bat and an owl cannot be classified under the same group. Write down two characteristics to differentiate a bat and an owl.



Mammal



Bird

a)

---



---

b)

---



---

[1]

(Go on to the next page)

20. After an excursion to the Botanic Gardens, Davi wrote a short journal entry on the plants he saw there. Read his account and answer the questions below.

Some plants were growing on trees. These plants had large green leaves. I touched one of the leaves and some tiny brown particles stuck to my hand. These particles were very light. I found more of these particles on the underside of the leaves.

- (a) What kind of plants did Davi write about? [1]

---

- (b) What are the brown particles called? [1]

---

- (c) What is the function of the brown particles?

---

- (d) What features make them suitable for their function? [1]

---

21. Study the classification below.

| P         | Q             |
|-----------|---------------|
| Rose      | Frangipani    |
| Tulip     | Ixora         |
| Sunflower | Bougainvillea |

What headings would you give to P and Q?

P: \_\_\_\_\_ [1]

Q: \_\_\_\_\_ [1]

22. Study the flow chart below.

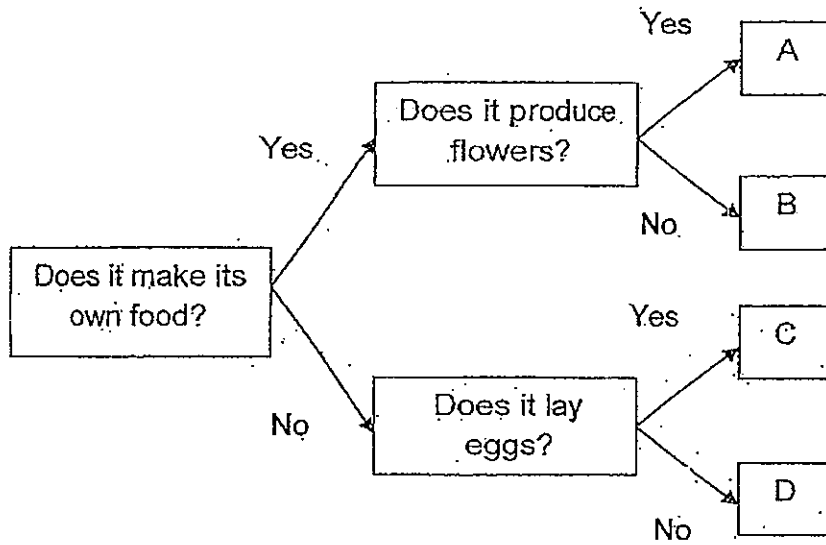

Write down the letters A, B, C and D correctly in the blanks provided. [2]

- a) Turtle \_\_\_\_\_  
 b) Heliconia \_\_\_\_\_  
 c) Rhinoceros \_\_\_\_\_  
 d) Staghorn Fern \_\_\_\_\_

23. The diagram below represents the structure of an animal (the positions of the legs are not shown).

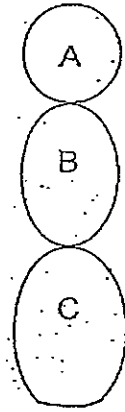

a) State the group that the animal belongs to. [1]

---

b) To which part of the body would its legs be attached? Write down the letter (A, B or C). [1]

---

c) Name the part that the legs would be attached to. [1]

---

END OF PAPER





# ANSWER SHEET

**EXAM PAPER 2013**

**SCHOOL : METHODIST GIRLS' SCHOOL**

**SUBJECT : PRIMARY 3 SCIENCE**

**TERM : CA1**

---

| Q1 | Q2 | Q3 | Q4 | Q5 | Q6 | Q7 | Q8 | Q9 | Q10 | Q11 | Q12 | Q13 | Q14 | Q15 |
|----|----|----|----|----|----|----|----|----|-----|-----|-----|-----|-----|-----|
| 3  | 4  | 3  | 4  | 1  | 3  | 2  | 4  | 2  | 4   | 3   | 3   | 2   | 2   | 4   |

Section B

Q16

- a) i) herbivore
- ii) carnivore
- b) Group 2

Q17

- a) Living things need food to survive
- b) Living things respond to changes in their surroundings

Q18

- a) 550g
- b) As it grows older, its mass increases.

Q19

- a) The bat gives birth to its young alive, while the owl lays eggs
- b) The owl has a beak while the bat does not have a beak.

Q20

- a) Ferns
- b) Spores
- c) To spread and grow into ferns

d) They are light and can be easily carried by wind

Q21

P: Grows singly/singularly

Q: Grows in clusters/bunches

Q22

a) C

b) A

c) D

d) B

Q23

a)insects

b) B

c) thorax



Rosyth School  
Topical Test for 2013  
SCIENCE  
Primary 3

Name: \_\_\_\_\_

Total  
Marks:

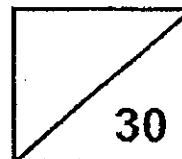

Class: Pr 3 \_\_\_\_\_

Register No. \_\_\_\_\_

Duration: 50min

Date: 4<sup>th</sup> March 2013

Parent's Signature: \_\_\_\_\_

Instructions to Pupils:

1. Do not open the booklet until you are told to do so.
2. Follow all instructions carefully.
3. This paper consists of 2 sections, Part I and Part II.
4. For questions 1 to 7, write the correct answer in the brackets provided.
5. For questions 8 to 12, give your answers in the spaces provided in Part II.

|         | Maximum  | Marks Obtained |
|---------|----------|----------------|
| Part I  | 14 marks |                |
| Part II | 16 marks |                |
| Total   | 30 marks |                |

\* This booklet consists of 8 pages. (pg. 1 to 8)

This paper is not to be reproduced in part or whole without the permission of the Principal.

**Part 1 (14 marks)**

For each question from 1 to 7, four options are given. One of them is the correct answer. Make your choice (1, 2, 3 or 4). Write the correct answer in the brackets provided.

1. Which of the following is/are true of a non-living thing?

- A: It can reproduce
- B: It can move by itself
- C: It does not need air, water and food

- (1) A only
  - (2) C only
  - (3) A and C only
  - (4) B and C only
- (      )

2. Ali was able to classify flowers into two groups. The first group of flowers has smell and the second group has no smell. Which one of the sense organs did he use?

- (1) Ears
  - (2) Eyes
  - (3) Nose
  - (4) Tongue
- (      )

3. Which of the following are groups of living things?

- A: Plants
- B: Animals
- C: Fungi
- D: Bacteria

- (1) A and B only
  - (2) B and D only
  - (3) A, B and C only
  - (4) A, B, C and D
- (      )

4. Refer to the flowchart below.

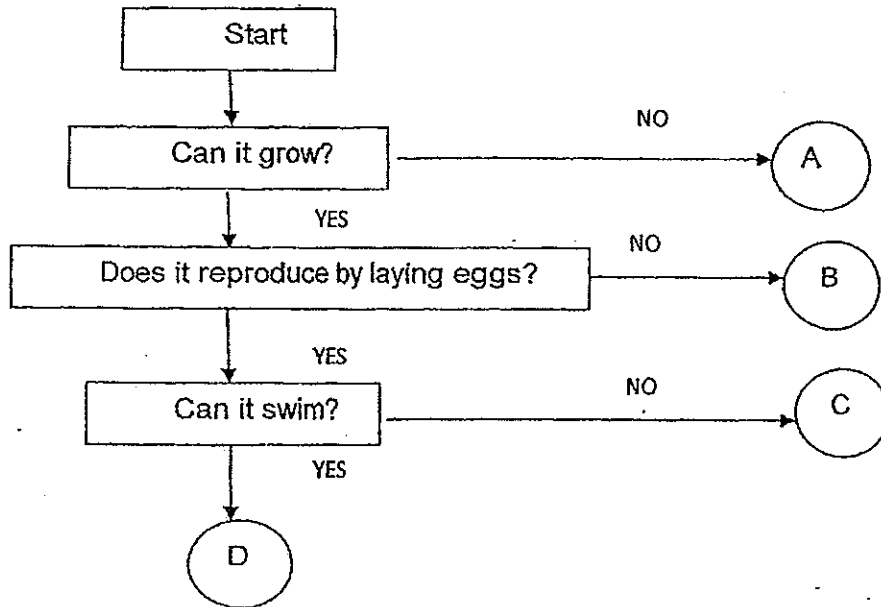

Which of the above is most likely to be a mammal?

- (1) A
  - (2) B
  - (3) C
  - (4) D
- ( )

5. Which of the followings are common characteristics of fish?

- A: All have gills
- B: All lay eggs
- C: All have fins
- D: All live in water

- (1) A and C only
  - (2) B and D only
  - (3) A, C and D only
  - (4) A, B, C and D
- ( )

6. Study the classification chart below.

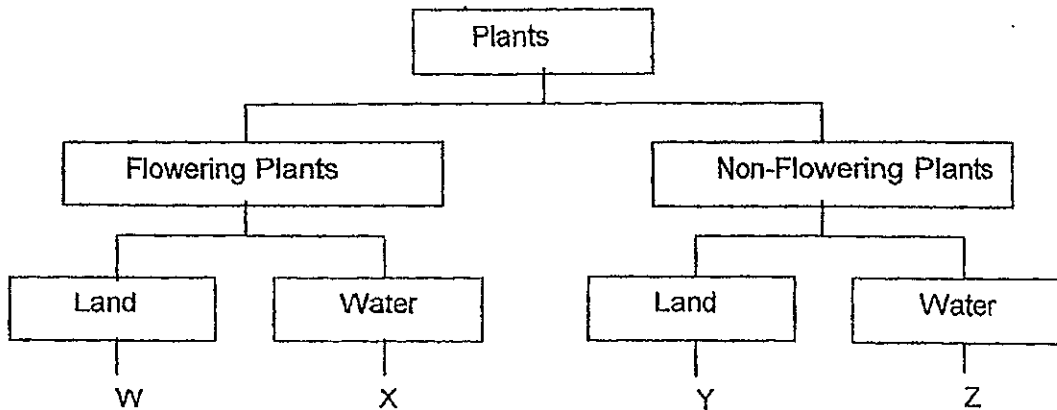

Read about the plant that Florence has found.  
 She found a plant in a pond. It was floating on the water. She turned the underside of the leaves and found neatly arranged spore bags.

In which group can the plant be placed?

- (1) W (2) X  
 (3) Y (4) Z ( )

7. Study the headings of two groups, R and S as shown in the table below.

|     | Group R                                | Group S                             |
|-----|--|-------------------------------------|
| (1) | Does not make its own food             | Makes its own food                  |
| (2) | Can be seen without using a microscope | Can only be seen using a microscope |
| (3) | Reproduce by splitting into two        | Reproduce by spores                 |
| (4) | Can move by itself                     | Cannot move by itself               |

Which headings can help to put bacteria in Group R and Fungi in Group S?

( )

End of Part 1

**Part II (16 marks)**

For questions 8 to 12, write your answers in the blanks provided.

8. Tom kept a mouse in a plastic container as shown below.

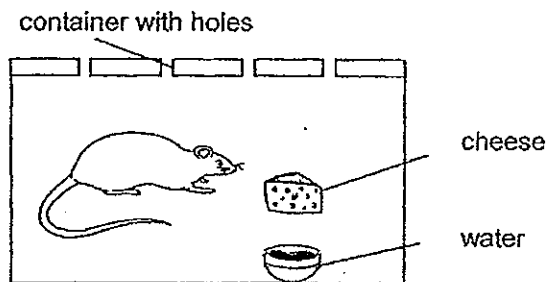

(a) After a month, the mouse was still alive. Explain why. (1m)

---

---

Tom also had a pot of plant with soil as shown below. He watered it every day. He observed that the pot of plant grew better when placed near a window than further away from the window.

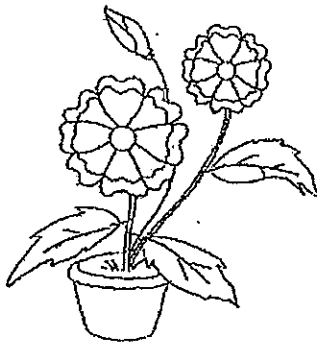

(b) Why does the plant grow better when placed near a window? (1m)

---

(c) Name two characteristics of living things not observed above. (1m)

---

---

9. Ariel found an organism P as shown below.

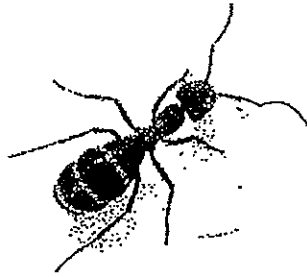

Organism P

(a) How many legs and body parts does the organism P have? (1m)

Legs: \_\_\_\_\_

Body parts: \_\_\_\_\_

(b) In which group of animals will you put organism P? (1m)

\_\_\_\_\_

After some time, the organism P started moving towards a sugar cube although it cannot see very well.

(c) Which sense has organism P used instead of sight? (1m)

\_\_\_\_\_

She saw another organism Q which belongs to the same group of animals.

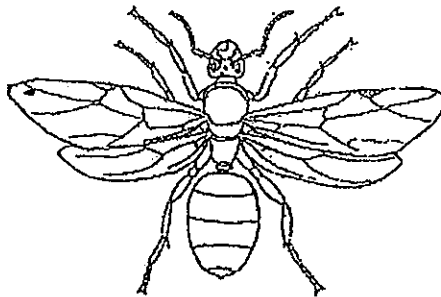

Organism Q

(d) State a difference between the two organisms, P and Q. (1m)

\_\_\_\_\_

\_\_\_\_\_



10. Mei saw an animal as shown below.

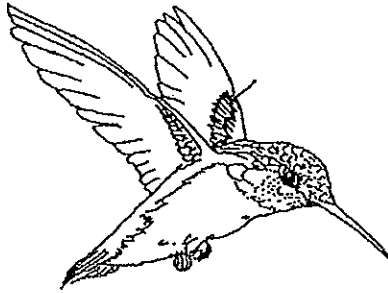

(a) Label the parts, **Beak** and **Feathers**, in the picture above. (1m)

(b) Which group of animals does the above animal belong to?  
Support your choice. (1m)

---

---

Mei wanted to classify the two groups, **Insects** and **Fish**, based on the number of legs.

(c) Complete the chart below to classify the two groups of animals. (2m)

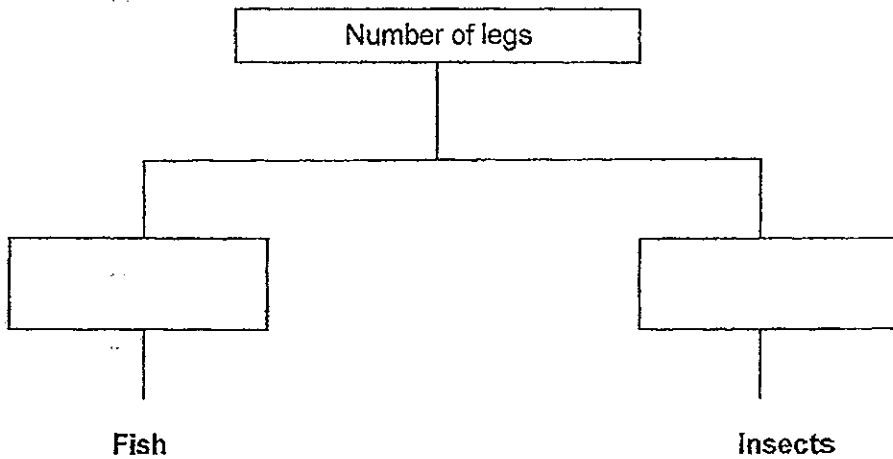

11. There were three groups of cows in a farm. Each group was fed with different types of food, A, B or C. The weights of the cows were recorded as shown in the table below.

| Time / Type of food | Food A                  | Food B | Food C |
|---------------------|-------------------------|--------|--------|
|                     | Weight of the cows (kg) |        |        |
| At Birth            | 20                      | 18     | 22     |
| 12 months           | 120                     | 130    | 110    |
| 24 months           | 180                     | 190    | 160    |
| 36 months           | 220                     | 240    | 200    |

- (a) Which type of food (A, B or C) caused the cows to grow the most?  
Support your choice. (1m)

---



---

The farmer observed that number of cows fed by food A has increased after 36 months.

- (b) Why was there an increase in the number of cows fed by food A? (1m)

---

12. Mr Tan carried out an experiment to find out if garlic juice is good at killing bacteria. He prepared three petri dishes, A, B and C, as shown in the table below.

| Petri dish | Things in the petri dish                                     |
|------------|--|
| A          | 10 ml of milk only   |
| B          | 10 ml of milk and a small amount of Bacteria E               |
| C          | 10 ml of milk ,a small amount of Bacteria E and garlic juice |

He recorded the size of the bacteria colony in the table below.

| Petri Dish | Size of bacteria colony (mm) |       |       |       |
|------------|------------------------------|-------|-------|-------|
|            | Day 1                        | Day 2 | Day 3 | Day 5 |
| A          | 0                            | 2     | 3     | 7     |
| B          | 0                            | 4     | 8     | 37    |
| C          | 0                            | 0     | 0     | 0     |

- (a) In which petri dishes are the bacteria growing? (1m)

---

- (b) Where do you think the bacteria came from in petri dish A? (1m)

---

- (c) Do you think garlic juice is good at killing bacteria?  
Support your choice. (1m)

---



---

End of Paper



# ANSWER SHEET

**EXAM PAPER 2013**

**SCHOOL : ROSYTH PRIMARY SCHOOL**

**SUBJECT : PRIMARY 3 SCIENCE**

**TERM : CA1 (TROPICAL TEST)**

---

| Q1 | Q2 | Q3 | Q4 | Q5 | Q6 | Q7 |
|----|----|----|----|----|----|----|
| 2  | 3  | 4  | 3  | 3  | 4  | 3  |

Section B

Q8

- a) It has air, food and water
- b) It has more sunlight to make food.
- c) Living things reproduce and respond to changes

Q9

- a) Legs: It has six legs  
Body parts: It has three body part
- b) Insects
- c) Touch, Taste, Smell and Hearing
- d) Organism Q has wings but organism P does not have wings.

Q10a)

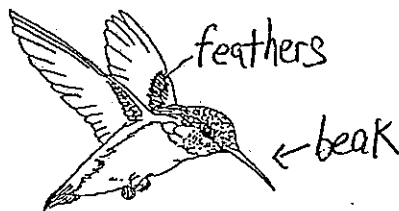

b) This animal belongs to birds, as it has feathers and a beak.

c)

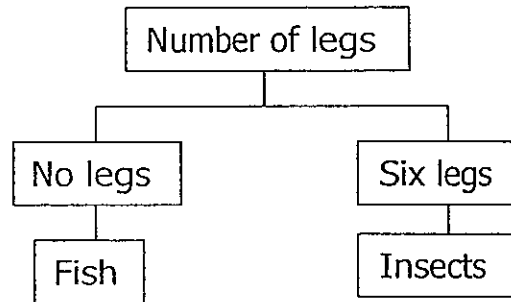

Q11

a) Food B, it has the highest kg.

b) The cows had reproduced.

Q12

a) A and B

b) The bacteria came from the milk

c) Yes, there is no bacteria in C because the garlic has killed the bacteria.

ANGLO-CHINESE SCHOOL  
(JUNIOR)



CONTINUAL ASSESSMENT 2 (2013)  
PRIMARY 3

SCIENCE

BOOKLET A

Monday

26 August 2013

50 minutes

Name : \_\_\_\_\_ ( )

Class : P3 \_\_\_

**INSTRUCTIONS TO PUPILS**

**DO NOT TURN OVER THE PAGES UNTIL YOU ARE TOLD TO DO SO**

Follow all instructions carefully.

There are 12 questions in this booklet.

Answer **ALL** questions.

**INFORMATION FOR PUPILS**

The total marks for this booklet is 24.

The total time for Booklets A and B is 50 minutes.

**This question paper consists of 6 printed pages. (Inclusive of cover page)**

**Section A (24 marks)**

For each question from 1 to 12, four options are given. One of them is the correct answer. Make your choice (1, 2, 3 or 4). Shade your answer on the Optical Answer Sheet.

- 1 The classification chart below shows how some things were classified according to certain characteristics.

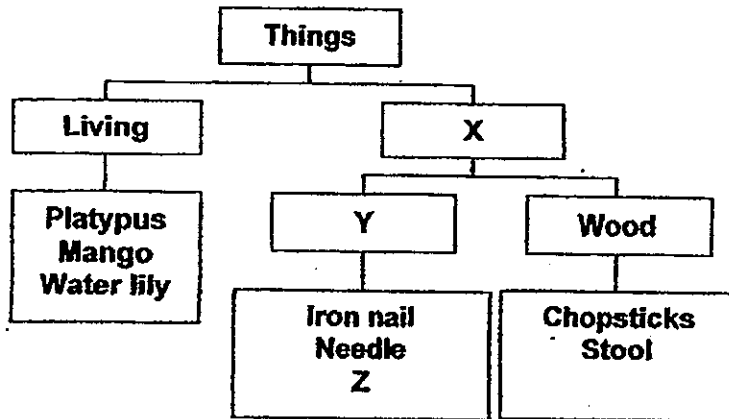

Which of the following clearly represents letters X, Y and Z?

|     | X          | Y       | Z          |
|-----|------------|---------|------------|
| (1) | Ceramic    | Metal   | Paper bag  |
| (2) | Non-living | Metal   | Paper clip |
| (3) | Non-living | Plastic | T-shirt    |
| (4) | Rubber     | Fabric  | Coin       |

- 2 Jensen observed two animals, P and Q, and recorded his observations in the table below.

| Characteristics                | Animal P | Animal Q |
|--------------------------------|----------|----------|
| Has gills                      | No       | Yes      |
| Has legs                       | Yes      | No       |
| Has wings                      | Yes      | No       |
| Gives birth to its young alive | No       | No       |

Which of the following could be animals P and Q?

|     | Animal P | Animal Q |
|-----|----------|----------|
| (1) | Mammal   | Fish     |
| (2) | Insect   | Bird     |
| (3) | Bird     | Fish     |
| (4) | Mammal   | Insect   |



3 The classification chart below shows how some things can be classified.

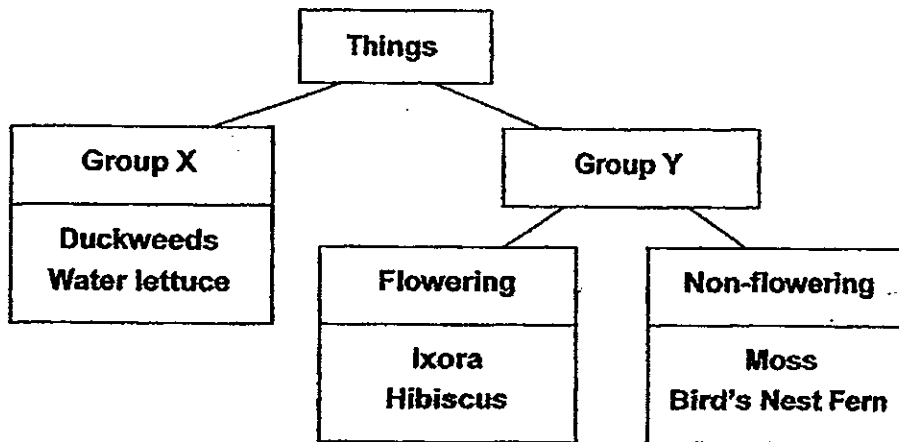

Which of the following sub-headings are most suitable for Groups X and Y?

|     | X                        | Y                             |
|-----|--------------------------|-------------------------------|
| (1) | Flowers that grow singly | Flowers that grow in clusters |
| (2) | Water plants             | Land plants                   |
| (3) | Has strong stem          | Has weak stem                 |
| (4) | Has large leaves         | Has small leaves              |

4 Which of the following is a living thing?

- (1) Cave
- (2) Fern
- (3) Stone
- (4) Ocean

5 How is the dragon scale fern different from a fungus?

- P It does not have flowers.
- Q It can make its own food.
- R It reproduces from spores.

- (1) P only
- (2) Q only
- (3) P and R only
- (4) Q and R only

6 The diagrams below show two fruits.

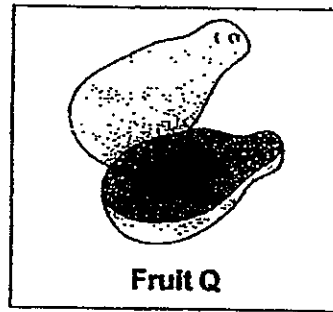
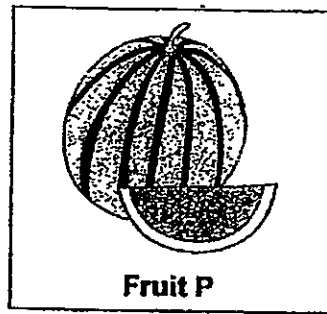

Based only on your observation of the above fruits, how are they similar?

- (1) They have rough skin.
- (2) They have many seeds.
- (3) They have similar shapes.
- (4) They have a similar pattern.

7 Joy read about some animals in an encyclopaedia and grouped them as shown below.

| Group A                   | Group B                    |
|---------------------------|----------------------------|
| Molly<br>Guppy<br>Dolphin | Cat<br>Giraffe<br>Elephant |

She grouped the animals according to \_\_\_\_\_.

- W where they live  
X how they move  
Y their outer coverings  
Z the way they reproduce
- (1) W and X only
  - (2) W and Z only
  - (3) X and Y only
  - (4) Y and Z only

8 Candy has written a riddle that describes an animal. Read the riddle below carefully.

"I live in a tree.  
I can fly and walk.  
My babies hatch from the eggs I lay.  
What am I?"

The riddle best describes a \_\_\_\_\_.

- (1) bat
- (2) lizard
- (3) mynah
- (4) platypus

9 Yvonne wanted to find out if the presence of light would affect the growth of fungi. She prepared two set-ups for the experiment.

She listed some variables which may affect the results of her experiment.

- A the amount of air present in the surroundings
- B the amount of light present in the surroundings
- C the amount of moisture present in the surroundings

Which of the above variable(s) must Yvonne keep the same for the two set-ups to ensure a fair test?

- (1) B only
- (2) A and C only
- (3) B and C only
- (4) A, B and C

10 Joan has classified some objects as shown below.

| Group X | Group Y |
|---------|---------|
| Plate   | Cushion |
| Fork    | Pillow  |
| Cup     | Bed     |

Which of the following are the correct headings for Group X and Group Y?

|     | Group X           | Group Y              |
|-----|-------------------|----------------------|
| (1) | Found in kitchen  | Found in bedroom     |
| (2) | Made of plastic   | Made of wood         |
| (3) | Found in bathroom | Found in living room |
| (4) | Made of fabric    | Made of ceramic      |

- 11 A car manufacturer has to decide on the best material to make the windscreen of a car. Some information on the four available materials is shown in the table below.

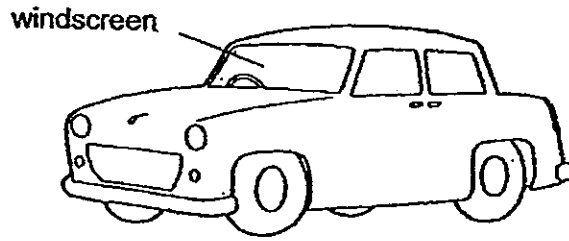

| Material | Properties                                    |
|----------|---|
| P        | Soft, waterproof and transparent              |
| Q        | Hard; waterproof and transparent              |
| R        | Soft, able to float on water and long-lasting |
| S        | Hard, able to float on water and long-lasting |

Which material is most suitable for making the windscreen?

- (1) P
- (2) Q
- (3) R
- (4) S

- 12 Study the flow chart below.

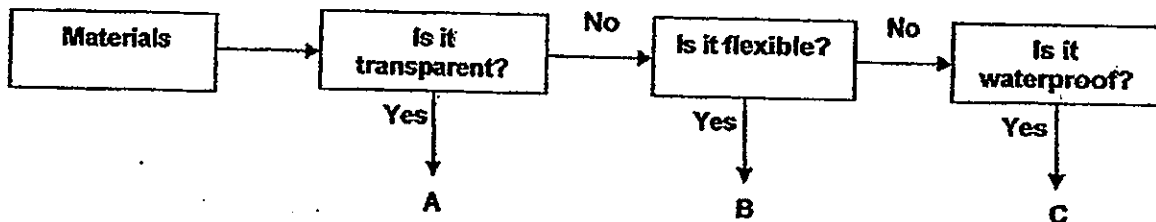

Which materials could A, B and C be?

|     | A     | B       | C       |
|-----|-------|---------|---------|
| (1) | glass | cloth   | plastic |
| (2) | wood  | rubber  | metal   |
| (3) | glass | metal   | rubber  |
| (4) | cloth | plastic | wood    |

ANGLO-CHINESE SCHOOL  
(JUNIOR)



CONTINUAL ASSESSMENT 2 (2013)  
PRIMARY 3

SCIENCE

BOOKLET B

Monday

26 August 2013

50 minutes

Name : \_\_\_\_\_ ( )

Class : P3 \_\_\_\_\_

**INSTRUCTIONS TO PUPILS**

DO NOT TURN OVER THE PAGES UNTIL YOU ARE TOLD TO DO SO

Follow all instructions carefully.

There are 6 questions in this booklet.

Answer ALL questions.

**INFORMATION FOR PUPILS**

The number of marks is given in brackets [ ] at the end of each question or part question.

The total marks for this booklet is 16.

The total time for Booklets A and B is 50 minutes.

This question paper consists of 7 printed pages. (Inclusive of cover page)

|                           |      |
|---------------------------|------|
| PRACTICAL                 | / 10 |
| BOOKLET A                 | / 24 |
| BOOKLET B                 | / 16 |
| TOTAL                     | / 50 |
| Parent's signature/ Date: |      |

**Section B (16 marks)**

For each question from 13 to 18, write your answer in the spaces provided

13 Kelly was given six figures, A, B, C, D, E and F, as shown below.

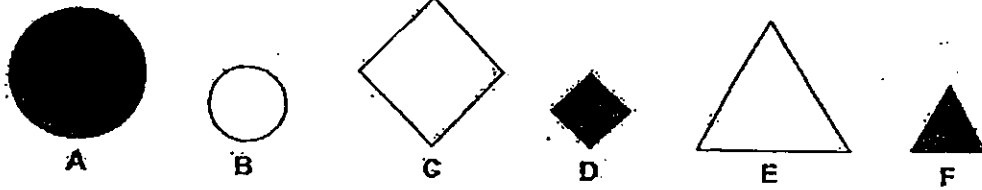

(a) State one characteristic which Kelly could use to classify the six figures into two groups so that there is an equal number of figures in each group. [1]

---

---

(b) Use another characteristic to regroup the six figures. Write the letters (A, B, C) D, E, F) in the two new groups. [1]

| Group 1: | Group 2: |
|----------|----------|
|          |          |

- 14 The table below gives information about four things based on some characteristics. A tick (✓) shows that the thing has the characteristic and a cross (x) shows that the thing does not have that characteristic.

| Characteristic                         | Thing |   |   |   |
|--|-------|---|---|---|
|  | W     | X | Y | Z |
| Can breathe through gills and can swim | ✓     | x | x | x |
| Can reproduce and can grow             | ✓     | ✓ | x | ✓ |
| Needs air, water and food              | ✓     | ✓ | x | ✓ |
| Can make its own food                  | x     | ✓ | x | x |

- (a) Fill in the boxes with the letter, W, X, Y or Z in the classification table below. [2]

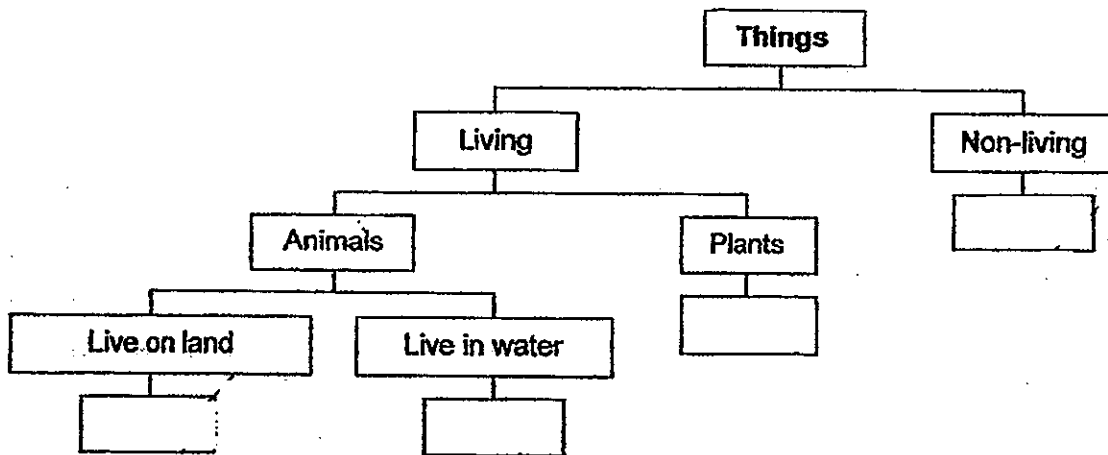

- (b) Based on the information from the table and chart, name a living thing that has the same characteristics as W. [1]

- 15 Rachel used three similar plants, A, B and C, to conduct an experiment to find out how the number of leaves the plant has would affect the amount of water taken in by the plant. She removed all the leaves from Plant A, and some leaves from Plant C. She then placed each plant in a container filled with 550 ml of water shown in the diagram below.

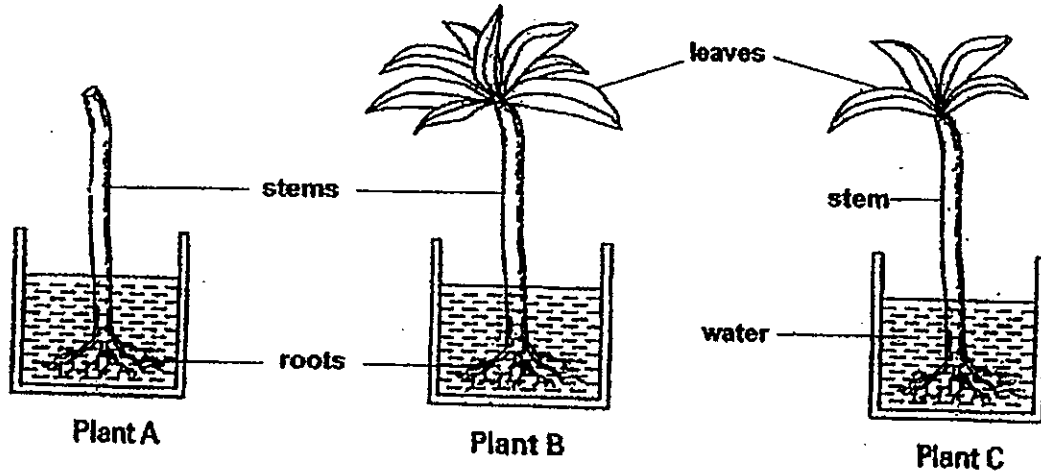

After 2 days, Rachel measured the amount of the water in each container. The table below shows the amount of water left in each container.

| Plant | Amount of water at first (ml) | Amount of water left after 2 days (ml) |
|-------|-------------------------------|--|
| A     | 550                           | 530                                    |
| B     | 550                           | 410                                    |
| C     | 550                           | 470                                    |

- (a) Based on the results in the table, state if each of the following statement is 'True', 'False' or 'Not possible to tell' by putting a tick (✓) in the correct box. [2]

|      | Statement                                  | True | False | Not possible to tell |
|------|--|------|-------|----------------------|
| (i)  | Plant A took in the least amount of water. |      |       |                      |
| (ii) | Plant C took in more water than plant B.   |      |       |                      |

- (b) Based on the results of the experiment, what can Rachel conclude? [1]

---



---

|  |
|--|
|  |
|--|



16 Study the flowchart carefully.

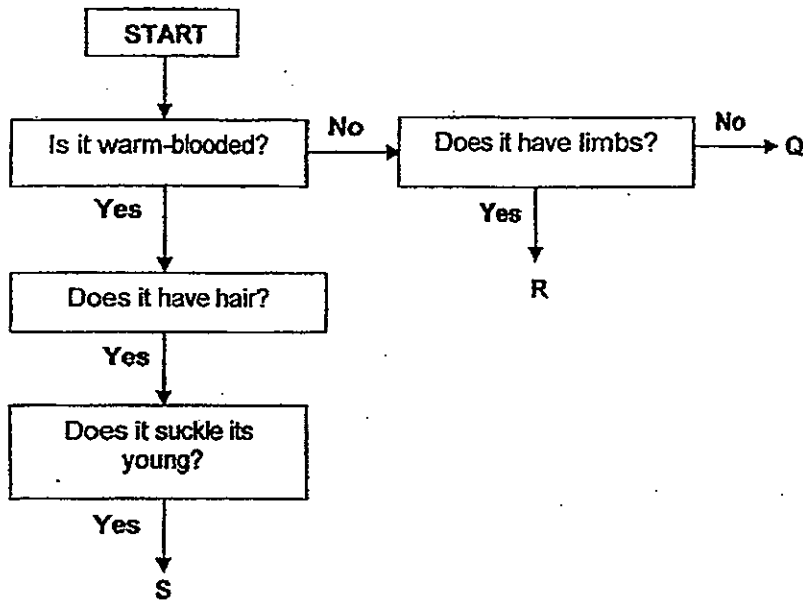

(a) Based on the flowchart, how is Q similar to R? [1]

---

---

(b) What type of animal could S be? [1]

---

- 17 Derek left a piece of bread in a plastic bag in the kitchen before he went on a tour for 2 weeks. When he reached home after 2 weeks, he found some black patches on the bread.

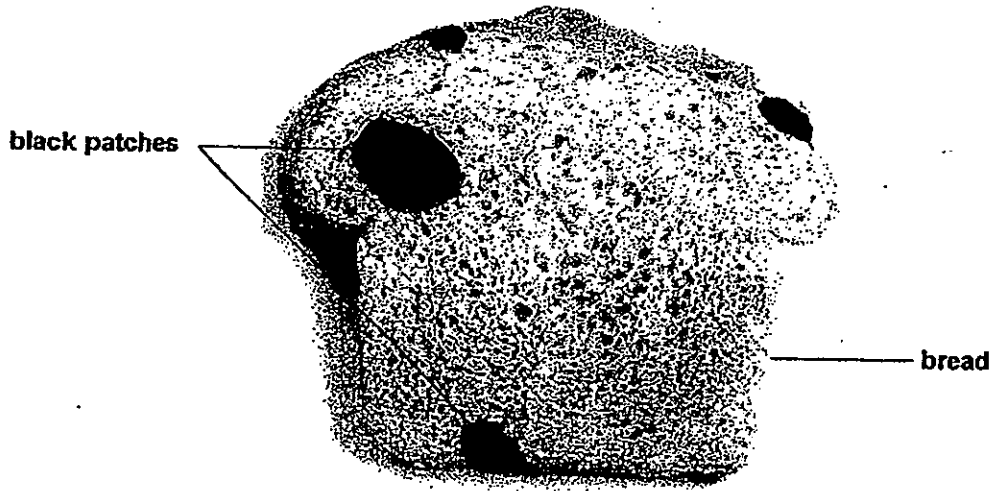

- (a) Derek's mother told him that the black patches are a type of micro-organisms. What type of micro-organisms are the black patches on the bread? [1]

---

- (b) List all the conditions needed for the micro-organisms to grow on the bread. [1]

---

- (c) What could Derek do to the piece of bread to prevent the micro-organism from growing on the bread? Why does this method work? [1]

---

---

|  |
|--|
|  |
|--|

- 18 Luke had four rods made of materials P, Q, R and S. He used every one of the four rods to scratch the other rods and wrote his observation below. A material is considered to be hard if it can scratch another material.

| Observation                                 |
|---|
| S scratched Q only.                         |
| R did not scratch P only.                   |
| P scratched all the other three rods.       |
| Q did not scratch all the other three rods. |

- (a) Based on Luke's observation, which material is the hardest and which material is the softest? [2]

Hardest: \_\_\_\_\_ Softest: \_\_\_\_\_

- (b) Luke then placed some weights on each of the four rods as shown below. He measured the mass of the weights added before the rod broke. He recorded his observation in the table below. A material is considered to be stronger if it can hold more weights than another material.

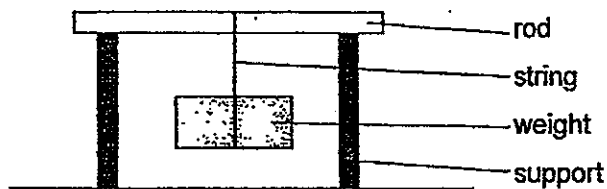

| Rod | Mass of weight added before the rod broke |
|-----|---|
| P   | 1050 g                                    |
| Q   | 270 g                                     |
| R   | 630 g                                     |
| S   | 790 g                                     |

- Based on Luke's observation, which material is most suitable for making a bag that can carry 1 kg of apples? [1]

\_\_\_\_\_

|  |
|--|
|  |
|--|



# ANSWER SHEET

## EXAM PAPER 2013

SCHOOL : ANGLO-CHINESE SCHOOL (JUNIOR)

LEVEL : PRIMARY 3

SUBJECT : SCIENCE

TERM : CA2

### BOOKLET A

|    |    |    |    |    |    |    |    |    |     |     |     |
|----|----|----|----|----|----|----|----|----|-----|-----|-----|
| Q1 | Q2 | Q3 | Q4 | Q5 | Q6 | Q7 | Q8 | Q9 | Q10 | Q11 | Q12 |
| 2  | 3  | 2  | 2  | 2  | 2  | 1  | 3  | 2  | 1   | 2   | 1   |

### BOOKLET B

Q13

(a) The characteristic is size.

(b)

|         |         |
|---------|---------|
| Group 1 | Group 2 |
| F D A   | C B E   |

Q14

(a)

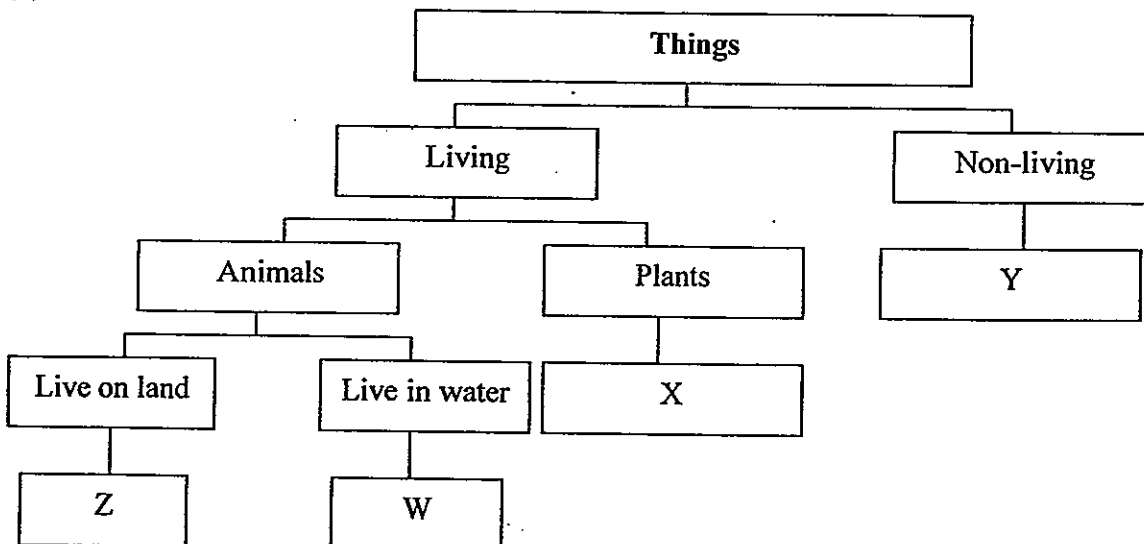

(b) A goldfish.

Q15

(a)

|      | Statement                                  | True | False | Not possible to tell. |
|------|--|------|-------|-----------------------|
| (i)  | Plant A took in the least amount of water. | √    |       |                       |
| (ii) | Plant C took in more water than plant B.   |      | √     |                       |

(b)

Plants with more leaves take in more water.

Q16

(a) Both Q and R are not warm-blooded.

(b) A tiger.

Q17

(a) The micro-organism is mould.

(b) It needs air, food and water/moisture.

(c) He could toast the bread to remove moisture and make it dry.

Q18

(a) Hardest: P Softest: Q

(b) Rod P.



HENRY PARK PRIMARY SCHOOL  
PRIMARY 3 SCIENCE 2013  
TEST 3

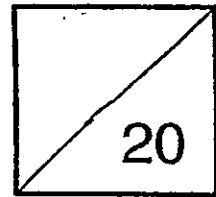

Duration of Paper: 45 min

Name: \_\_\_\_\_

Parent's Signature \_\_\_\_\_

Class: Primary 3 \_\_\_\_\_

**Section A: Multiple-Choice Questions (5 x 2 marks = 10 marks)**

For each question from 1 to 5, four options are given. One of them is the correct answer. Make your choice (1, 2, 3 or 4). Write your answer in the brackets provided.

1. The table below shows how some materials are classified.

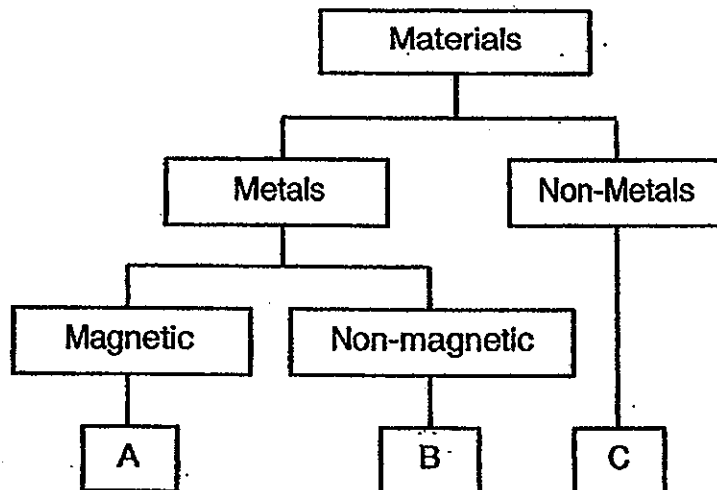

Which one of the following best represents material A, B and C?

|     | A      | B         | C      |
|-----|--------|-----------|--------|
| (1) | Copper | Fabric    | Gold   |
| (2) | Steel  | Aluminium | Glass  |
| (3) | Iron   | Nickel    | Wood   |
| (4) | Copper | Cobalt    | Rubber |

( )

2. Danny wanted to find out which parts of a horse-shoe magnet are the strongest. He labelled the magnet with different parts A, B, C and D as shown below and recorded the number of paperclips attracted to each part.

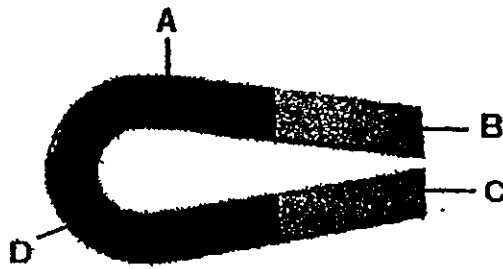

Which one of the following most likely shows the number of paper clips attracted by each part of the horse-shoe magnet?

|     | A | B | C | D |
|-----|---|---|---|---|
| (1) | 0 | 1 | 3 | 4 |
| (2) | 4 | 0 | 1 | 3 |
| (3) | 3 | 4 | 0 | 1 |
| (4) | 1 | 3 | 4 | 0 |

( )



3. The diagram below shows a toy car with iron wheels placed on a track made from different materials.

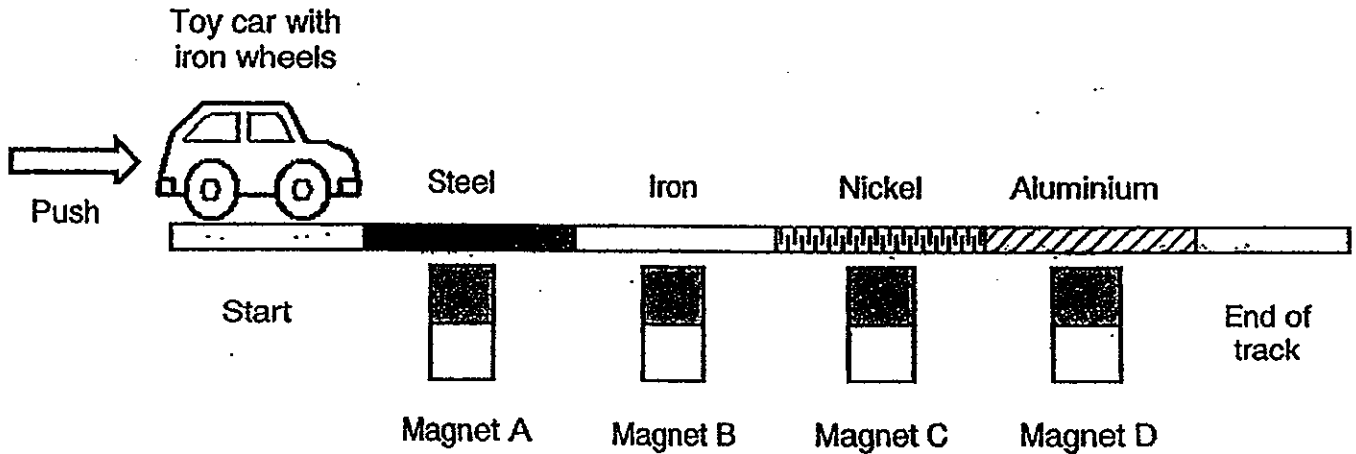

Which of the following best describes what happens to the car as it is pushed along the track as shown above?

- (1) All the magnets will attract the iron wheels of the car.
- (2) None of the magnets will attract the iron wheels of the car.
- (3) Magnet A will stop the car because magnetism passes through steel.
- (4) Magnet D will stop the car because magnetism passes through aluminium.

( )

4. Ali wanted to find out how the number of strokes affects the strength of a magnet:

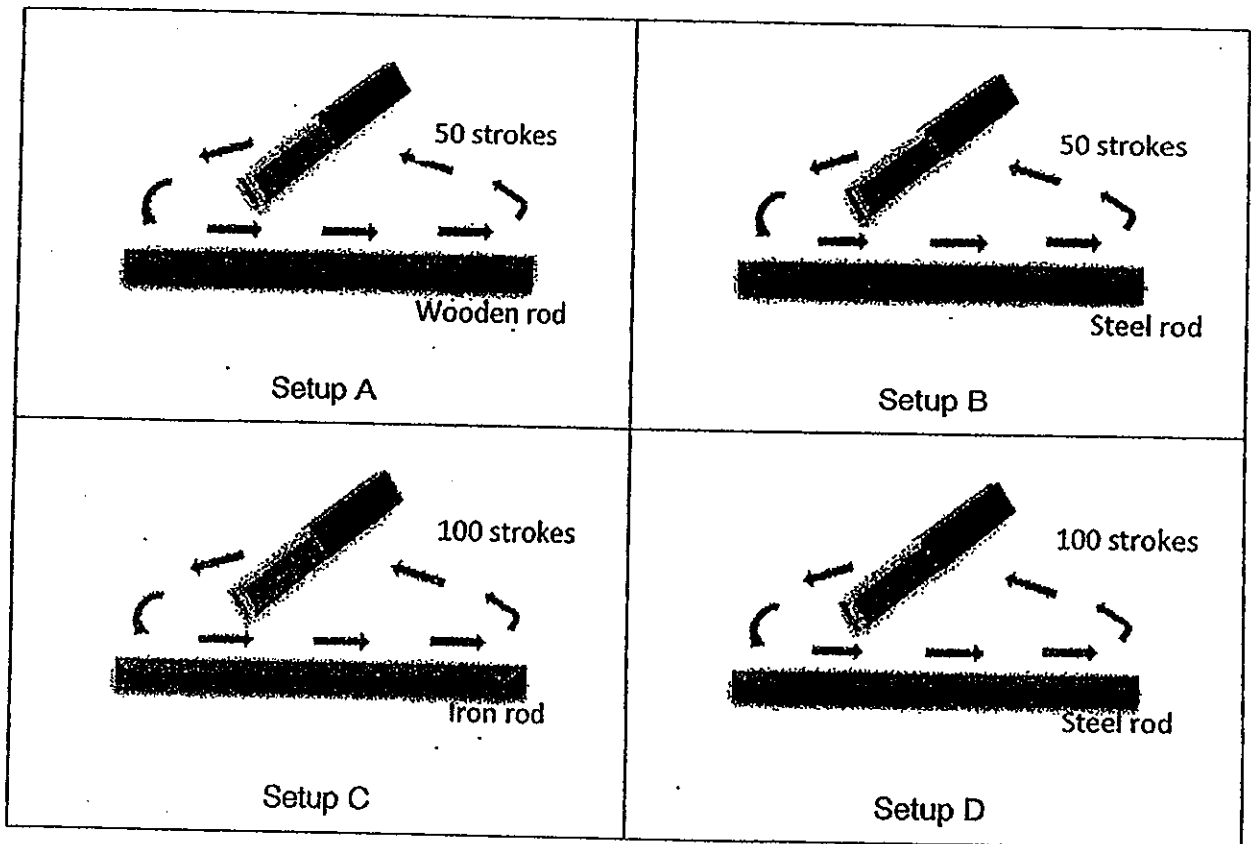

Which two setups should he use for a fair experiment?

- (1) Setup A and Setup B
- (2) Setup A and Setup C
- (3) Setup B and Setup D
- (4) Setup C and Setup D

( )

5. John compared three rulers made of three different materials.

Ruler A: Made of metal

Ruler B: Made of plastic

Ruler C: Made of wood

John then made some observations of the rulers in the table below.

|   |
|---|
| Ruler A is harder to bend than Ruler C. |
| Ruler B bends easier than Ruler A.      |
| Ruler C breaks when bent.               |

Which property of materials is John comparing?

- (1) Hardness
- (2) Flexibility
- (3) Strength
- (4) Able to float on water

**Section B: Structured Questions (2 x 2 marks = 4 marks)**

For questions 6 and 7, write your answers in the spaces provided.

6. In the diagram below, P, Q, R and S are metal rings stacked on a wooden base with a wooden bar. They are either magnets or made of magnetic materials.

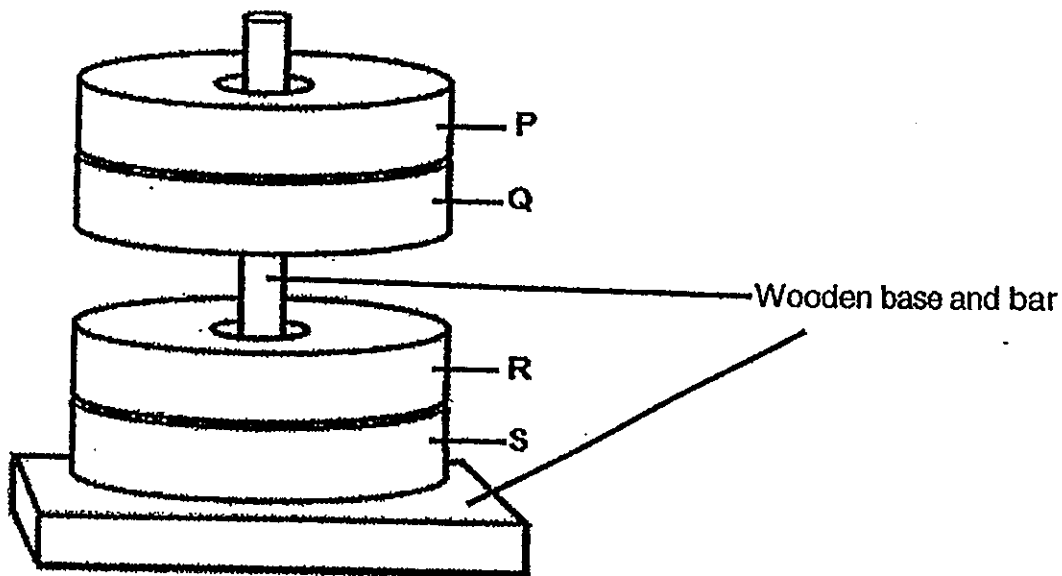

Based on the diagram above, put a tick (✓) in the column that best describes metal ring P, Q, R and S. [2m]

| Metal Ring | Definitely a magnet | Can be a magnet or magnetic metal |
|------------|---------------------|-----------------------------------|
| P          |                     |                                   |
| Q          |                     |                                   |
| R          |                     |                                   |
| S          |                     |                                   |

7. Match the following descriptions to the correct characteristics of living things.

Descriptions

A frog lays eggs in the water.

The mimosa plant closes its leaves when touched.

Mary's feet cannot fit into her old shoes anymore.

Ben walks to school every morning.

Characteristics of Living Things

Living things grow.

Living things reproduce.

Living things move by themselves.

Living things respond to changes around them.

**Section C: Open-Ended Questions (6 marks)**

For questions 8 and 9, write your answers clearly in the spaces provided.

8. Lena dropped 6 iron thumbtacks onto the floor and they rolled under a heavy cupboard. She retrieved 3 of the thumbtacks by holding a small magnet on the floor by the cupboard.

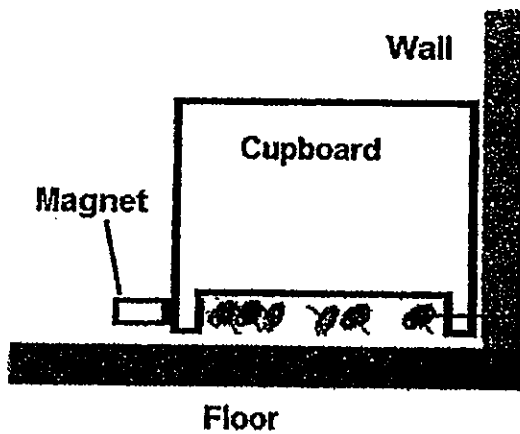

Picture 1 – Using small magnet

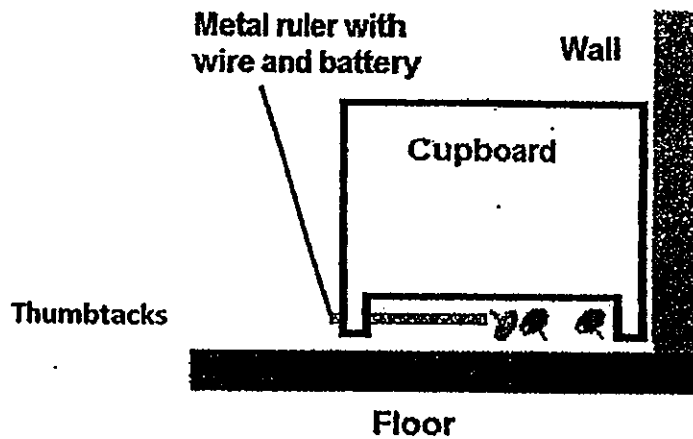

Picture 2 – Using metal ruler, wire and battery

Lena tried sliding her metal ruler under the cupboard but it was too short to reach the thumbtacks. So she coiled some wire around her long metal ruler, connected the ends of the wire to a battery and pushed the ruler under the cupboard. This time she retrieved 2 thumbtacks.

- (a) Lena retrieved 3 thumbtacks with her small magnet.

Give a reason why the other thumbtacks were not attracted to her small magnet. [1m]

---

---

- (b) Explain how Lena retrieved 2 more thumbtacks using a ruler, wire and battery. [1m]

---

---

- (c) State one change Lena could make to her setup in Picture 2 to retrieve the last thumbtack **without changing the ruler**. [1m]

---

---

9. Janet wanted to find out if the material of an object will affect whether it floats or sinks in water. She conducted her experiment by dropping 4 objects, A, B, C and D made of different materials into the water tank as shown below.

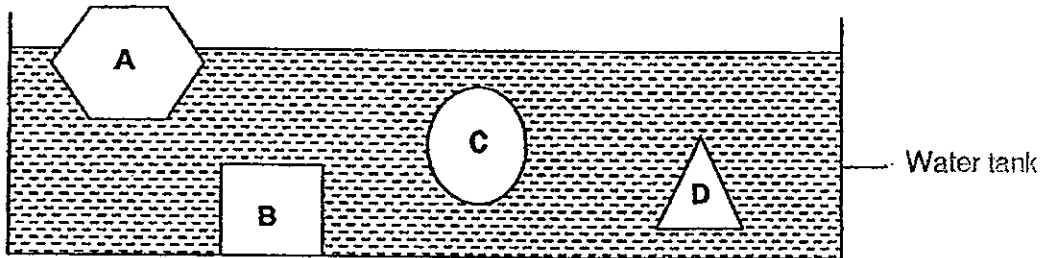

- (a) Based on the diagram above, is the experiment a fair test?

Explain your answer. [2m]

---

---

---

---

Fishermen release a sea anchor into the sea to stop their boat from moving. The anchor drops to the bottom of the sea bed and allows them to fish at the same spot without the boat moving.

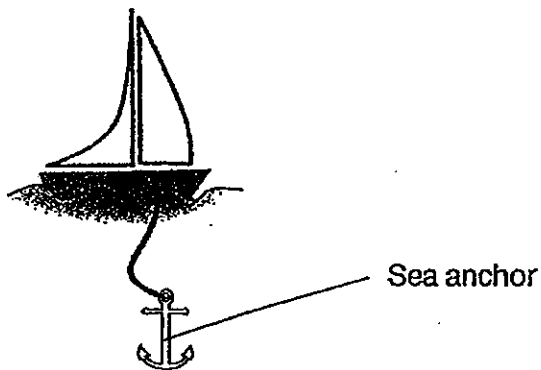

- (b) Based on Janet's experiment results above, which material, A, B, C or D would be most suitable for a sea anchor? [1m]

--- END OF PAPER ---





# ANSWER SHEET

**EXAM PAPER 2013**

**SCHOOL : HENRY PARK PRIMARY SCHOOL**

**SUBJECT : PRIMARY 3 SCIENCE**

**TERM : CA2**

|    |    |    |    |    |
|----|----|----|----|----|
| Q1 | Q2 | Q3 | Q4 | Q5 |
| 2  | 4  | 4  | 3  | 2  |

Section B

Q6)

| Metal Ring | Definitely a magnet | Can be magnet or magnetic material |
|------------|---------------------|------------------------------------|
| P          |                     | ✓                                  |
| Q          | ✓                   |                                    |
| R          | ✓                   |                                    |
| S          |                     | ✓                                  |

Q7)

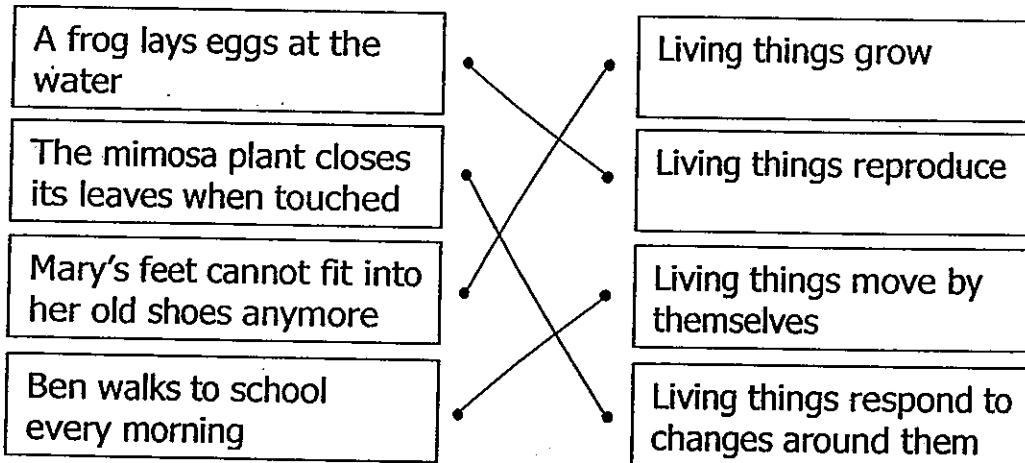

Q8

- a) The magnetic strength is not strong enough to attract the thumbtacks
- b) The metal ruler became an electromagnet
- c) Out more batteries and turn more coils

Q9

- a) No. They are not the same shape or size
- b) Material B

**Pei Chun Public School**  
**Continual Assessment – 2013**  
**Science**  
**Primary 3**

Name : \_\_\_\_\_ (     ) Date : 30 August 2013





Class : Pr. 3

Science Teacher \_\_\_\_\_ Time : 1h 30 min

**Section A (25 × 2 marks)**

For questions 1 to 25, choose the most suitable answer and shade its number (1, 2, 3 or 4) on the Optical Answer Sheet (OAS) provided.

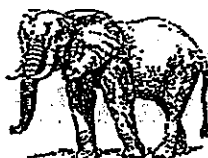
1. Study the classification table below.

| <b>Animals</b>  |  |
|---|--|
| <b>Group A</b>  | <b>Group B</b>   |
| <br><br> | <br><br> |

Which of the following correctly shows how the above animals are classified?

|     |                                  |                                |         |
|-----|----------------------------------|--------------------------------|---------|
|     | <b>Group A</b>                   | <b>Group B</b>                 |         |
| (1) | have no legs                     | have legs                      |         |
| (2) | animal-eaters                    | plant-eaters                   |         |
| (3) | move by crawling                 | move by flying                 |         |
| (4) | have an outer covering of scales | have an outer covering of hair | (     ) |

2. The table below shows the characteristics of A, B, C and D.

| Characteristics                         | A | B | C | D |
|---|---|---|---|---|
| Has four legs                           | ✓ |   |   |   |
| Can make its own food                   |   | ✓ |   |   |
| Needs air, food and water               |   | ✓ | ✓ |   |
| Can move from place to place on its own | ✓ |   | ✓ | ✓ |

Which of the following, A, B, C or D, is a living thing?

- (1) A and D only
- (2) B and C only
- (3) A, C and D only
- (4) All of the above

( )

3. The diagrams below show Organisms X and Y.

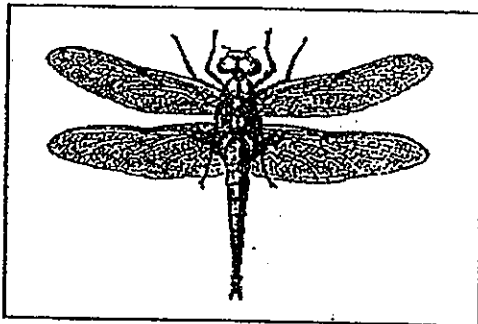

Organism X

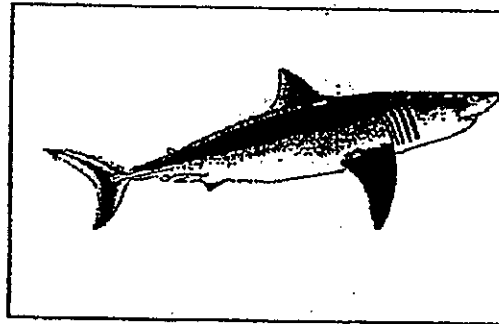

Organism Y

In what ways are Organisms X and Y similar?

- A Both live in water.
- B Both reproduce by laying eggs.
- C Both move around to look for food.
- D Both have the same outer covering.

- (1) A and B only
- (2) A and C only
- (3) B and C only
- (4) C and D only

( )

4. Elise conducted several tests on three materials, S, T and U. She recorded her observations in the table below.

|                     | S   | T   | U   |
|---------------------|-----|-----|-----|
| bends easily        | yes | no  | yes |
| absorbs water       | yes | no  | no  |
| breaks when dropped | no  | yes | no  |

Which of the following shows what materials S, T and U are likely to be?

|     | S       | T       | U       |
|-----|---------|---------|---------|
| (1) | rubber  | glass   | metal   |
| (2) | metal   | rubber  | ceramic |
| (3) | ceramic | metal   | fabric  |
| (4) | fabric  | ceramic | rubber  |

( )

5. Study the classification diagram.

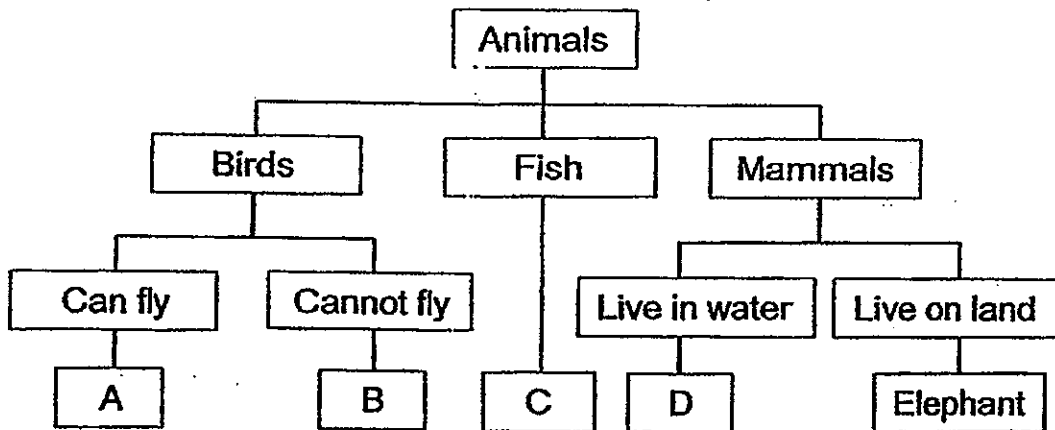

Which of the following letters, A, B, C or D, represents a whale in the classification diagram?

- (1) A  
 (2) B  
 (3) C  
 (4) D
- ( )

6. Ali grouped the following animals together according to how they reproduce. Based on the grouping, which one of the animals does not fit into the group?



(1) Platypus



(2) Ostrich



(3) Porcupine



(4) Butterfly

( )

7. Hashim is learning about living things. He makes the following observations.

- A boy shivers when he feels cold.
- A mouse runs away when chased by a cat.
- A dog pants and hangs its tongue out after running in the sun.

His observations show that living things \_\_\_\_\_.

- (1) need warmth to survive
- (2) respond to changes around them
- (3) change in their behaviour as they grow
- (4) can move from place to place on their own

( )

8. Linda saw a strange creature with its young clinging to it in the jungle. Both their bodies were covered with soft brown hair. The young was feeding on its mother's milk.

Which group of animals does the creature belong to?

- (1) fish
- (2) birds
- (3) insects
- (4) mammals

( )

9. Ann, Belle, Carl and Dan compared the characteristics of bread mould and bird's nest fern as shown below.

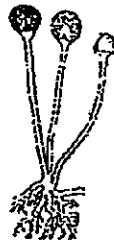

bread mould  
seen under a microscope



bird's nest fern  
seen with the naked eye

They made the following statements.

- Ann : Both are plants.
- Belle : Both reproduce from spores.
- Carl : Bread mould cannot make its own food but bird's nest fern can.
- Dan : Both need air, food and water to survive.

Whose statements are correct?

- (1) Ann and Belle only
- (2) Belle and Carl only
- (3) Ann, Belle and Carl only
- (4) Belle, Carl and Dan only

( )

10. Dinesh set up an experiment to find out the best conditions to grow bread mould as shown below. The slices of bread were placed in sealed bags in all four set ups.



Set-up A  
toasted bread  
kept in a warm place

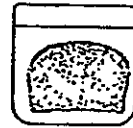

Set-up B  
toasted bread  
kept in a refrigerator

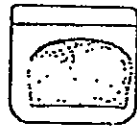

Set-up C  
bread not toasted  
kept in a warm place



Set-up D  
bread not toasted  
kept in a refrigerator

He observed that bread mould started appearing on the bread at different times. In which of the above set-ups, A, B, C or D, will bread mould most likely appear first?

- (1) A
- (2) B
- (3) C
- (4) D

( )



11. Study the classification table below.

| Fruits               |                          |                         |                           |
|----------------------|--------------------------|-------------------------|---------------------------|
| Smooth skin          |                          | Rough skin              |                           |
| One seed             | Many seeds               | One seed                | Many seeds                |
| mango<br>cherry<br>P | apple<br>watermelon<br>Q | lychee<br>rambutan<br>R | durian<br>rock melon<br>S |

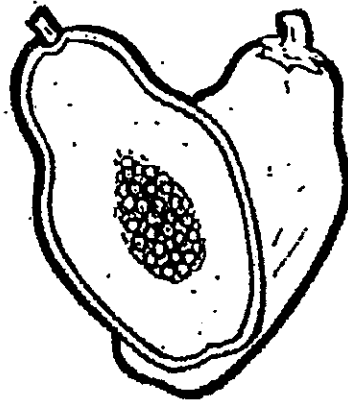

Papaya

Which fruit, P, Q, R or S, can be represented by the above fruit, Papaya?

- (1) P
- (2) Q
- (3) R
- (4) S

( )

12. Study the flow chart and diagrams of the plants below.

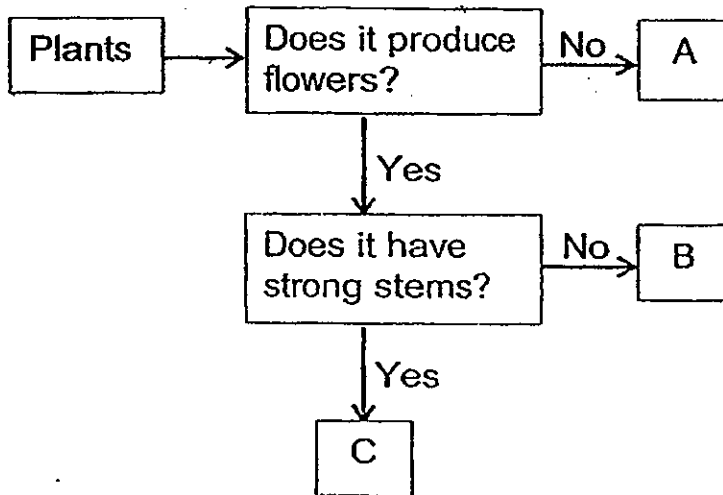

Balsam

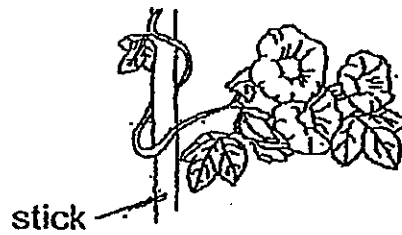

Morning glory



Bird's nest fern

Which of the following matches the above plants to the letters A, B and C?

|     | A                | B                | C                |
|-----|------------------|------------------|------------------|
| (1) | Balsam           | Morning glory    | Bird's Nest Fern |
| (2) | Bird's Nest Fern | Balsam           | Morning glory    |
| (3) | Morning glory    | Bird's Nest Fern | Balsam           |
| (4) | Bird's Nest Fern | Morning glory    | Balsam           |

13. Which of the following statements is true about bacteria?

- (1) All bacteria are harmful.
- (2) Bacteria are not living things.
- (3) Bacteria reproduce by spores.
- (4) Bacteria can respond to changes. ( )

14. Li Ming used an iron nail to make scratches on Material A and Material B as shown below.

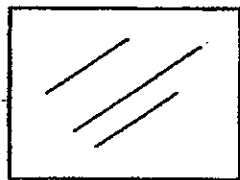

Material A

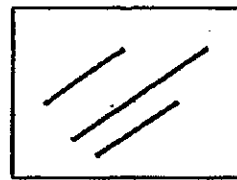

Material B

Based on the information provided, which of the following is true about materials A and B?

- (1) Material A is harder than Material B.
- (2) Material A is stronger than Material B.
- (3) Material B is stronger than Material A.
- (4) Material B is more flexible than Material A. ( )

15. The diagram below shows an iron.

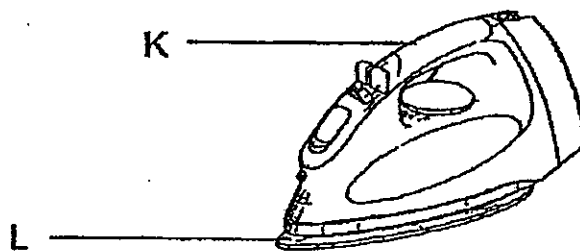

Which materials are used to make parts K and L?

|     | K       | L       |
|-----|---------|---------|
| (1) | plastic | metal   |
| (2) | glass   | plastic |
| (3) | plastic | glass   |
| (4) | metal   | glass   |

( )

16. Jenny placed a bar magnet on a piece of styrofoam. The magnet was left to turn freely in a basin of water while floating on the styrofoam as shown below.

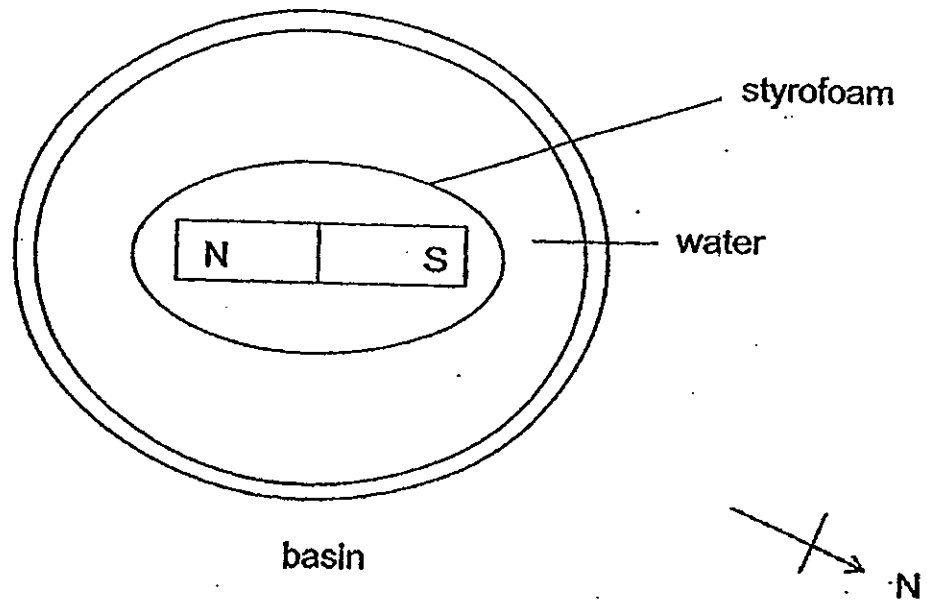

Which of the following shows the correct position of the magnet after some time?

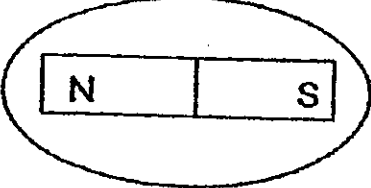
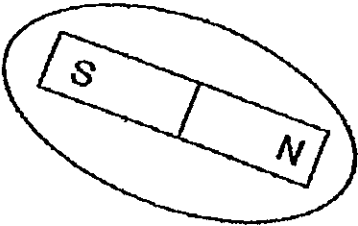
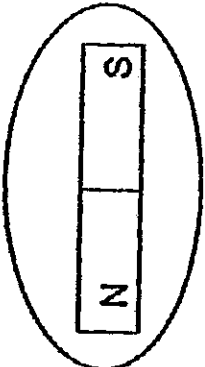
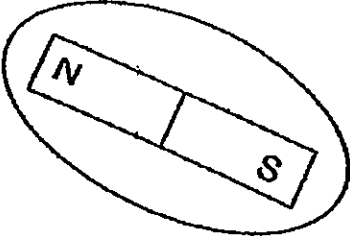
- (1) 
- (2) 
- (3) 
- (4) 

( )

17. Study the classification table below.

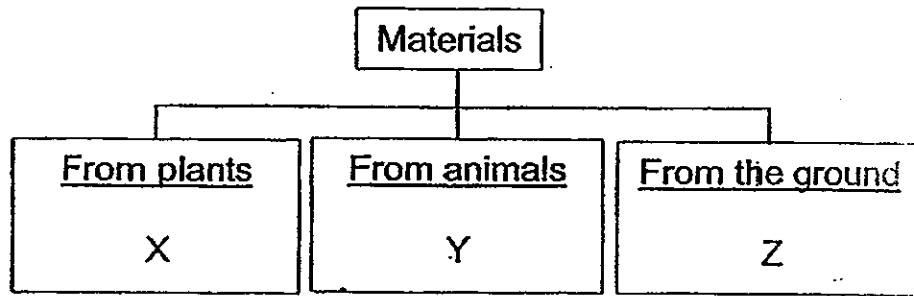

Which of the following represents X, Y and Z?

|     | X       | Y       | Z      |
|-----|---------|---------|--------|
| (1) | rubber  | silk    | iron   |
| (2) | plastic | rubber  | silver |
| (3) | silk    | wood    | rubber |
| (4) | wood    | plastic | silk   |

18. Which one of the objects is wrongly classified?

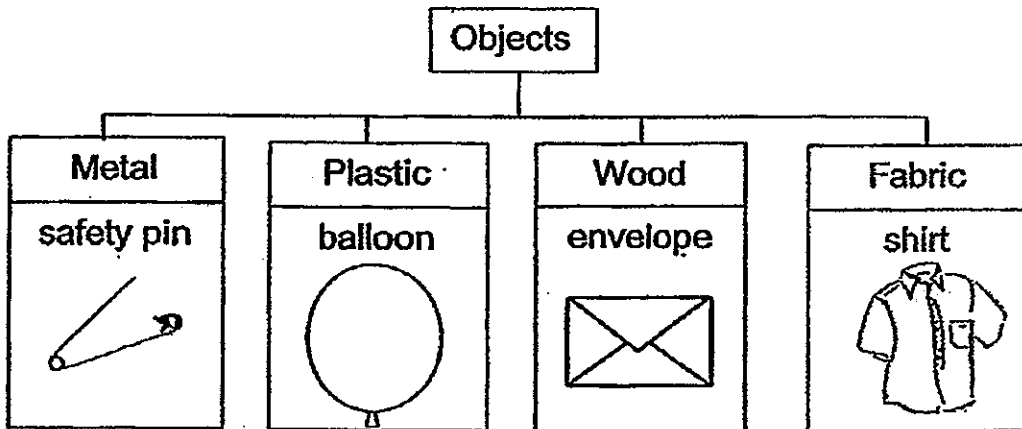

- (1) shirt
- (2) balloon
- (3) envelope
- (4) safety pin

19. The diagram below shows a pair of swimming goggles. Parts X and Y are made of different materials.

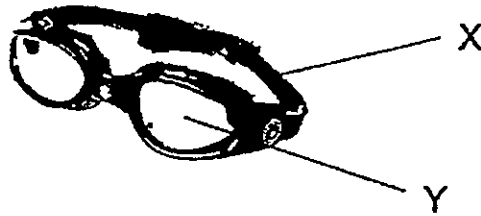

The materials used to make parts X and Y are both waterproof. Which of the following shows another property that X and Y each must have?

|     | X                            | Y                            |
|-----|------------------------------|------------------------------|
| (1) | allows light to pass through | hard                         |
| (2) | be able to float             | be able to float             |
| (3) | flexible                     | allows light to pass through |
| (4) | hard                         | flexible                     |

( )

20. Miki wanted to find out which parts of the U-shape magnet attracted the most paper clips.

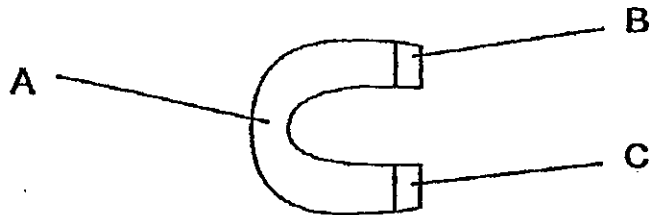

Which of the following shows the most likely number of paper clips attracted to Parts A, B and C?

|     | Number of paper clips attracted |   |   |
|-----|---------------------------------|---|---|
|     | A                               | B | C |
| (1) | 0                               | 5 | 5 |
| (2) | 5                               | 0 | 0 |
| (3) | 5                               | 5 | 5 |
| (4) | 10                              | 5 | 5 |

( )

21. Mei Mei brought one end of a bar magnet near objects X, Y and Z one at a time.

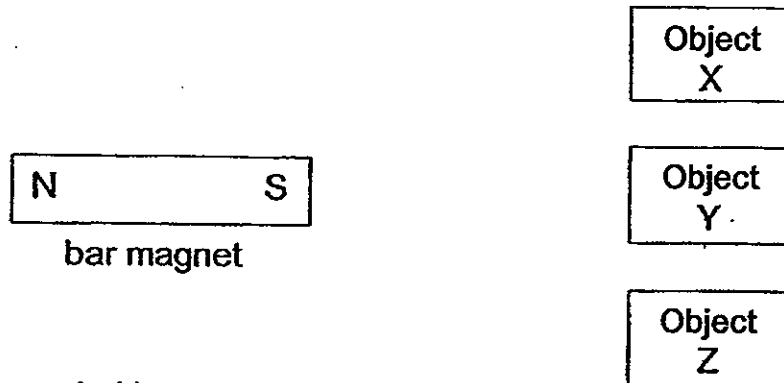

She recorded her observations below.

- Object X is repelled.
- Object Y is attracted.
- Object Z does not move.

Based on her observations, which of the following is/are definitely a magnet/ magnets?

- (1) Object X only
- (2) Object Z only
- (3) Object X and Y only
- (4) Object Y and Z only

( )

22. Study the table of things below.

| Group R  | Group S |
|----------|---------|
| bacteria | water   |
| seed     | kite    |

Which of the following can be added to Group R and Group S?

|     | Group R | Group S |
|-----|---------|---------|
| (1) | table   | snake   |
| (2) | ant     | wind    |
| (3) | fan     | algae   |
| (4) | fire    | candle  |

( )

23. Aisha made electromagnets using Set-ups A, B and C. The batteries, iron rods and wires used were identical.

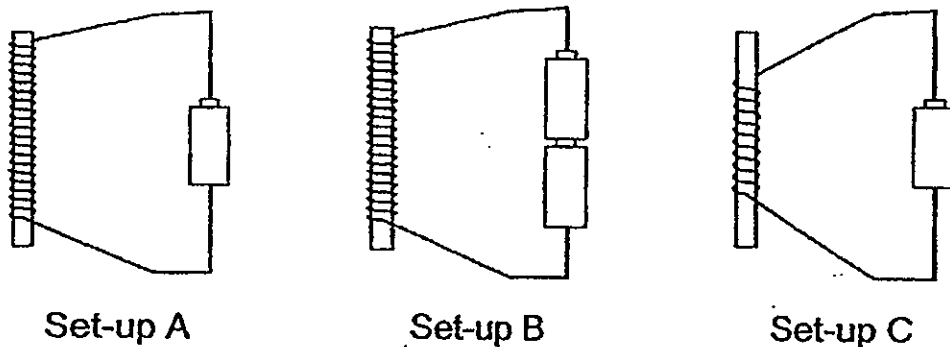

She then arranged the Set-ups A, B and C from the one that attracts the least number of paper clips to the one that attracts the most. Which of the following shows the correct order?

least                      →                      most

- |     |    |    |   |         |
|-----|----|----|---|---------|
| (1) | A, | B, | C | (     ) |
| (2) | B, | A, | C |         |
| (3) | C, | A, | B |         |
| (4) | C, | B, | A |         |

24. Study the classification diagram below.

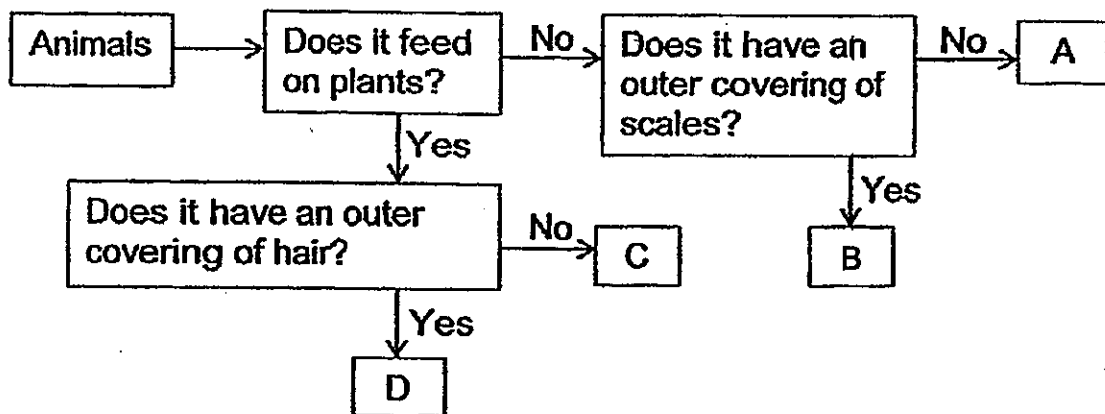

Lucy was given a pet animal with hair on its body. It feeds on plants. Based on the classification diagram, which of the following, A, B, C or D, represents Lucy's pet animal?

- |     |   |         |
|-----|---|---------|
| (1) | A | (     ) |
| (2) | B |         |
| (3) | C |         |
| (4) | D |         |



25. Raja has four magnets, A, B, C and D. He carried out an experiment to find out which magnet was the strongest. The diagram below shows the number of paper clips attracted by each magnet.

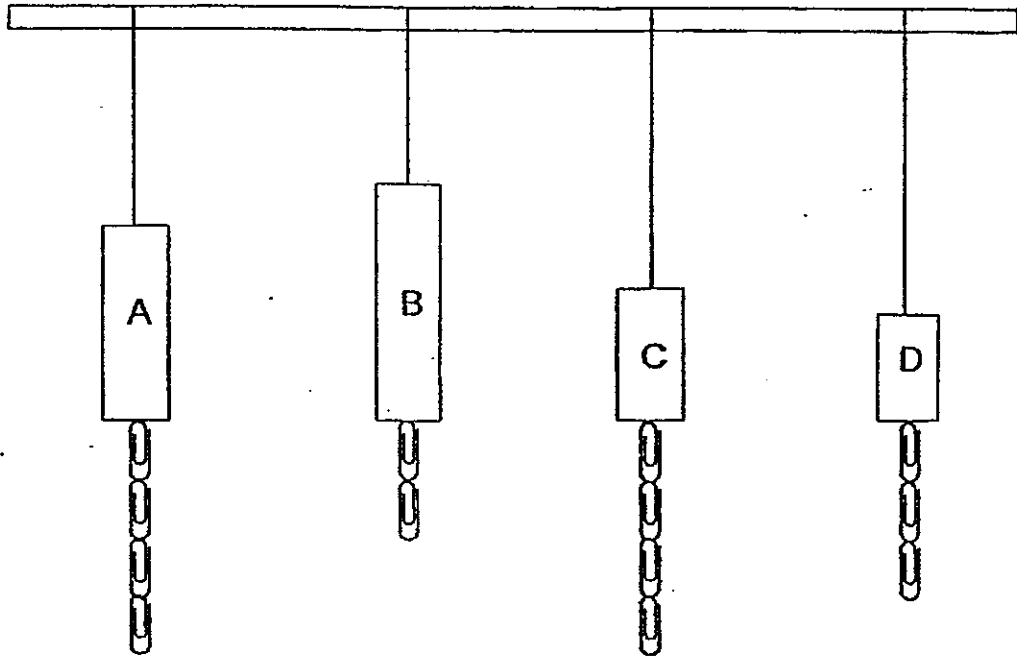

Based on the diagram, which of the following statements is true?

- (1) Magnet A is stronger than Magnet C.
- (2) Magnet B is weaker than Magnet D.
- (3) Magnet B is the strongest.
- (4) Magnet D is the weakest.

(     )

**For Questions 26 to 30, please refer to Booklet K.**

**End of Section A**

**Pei Chun Public School**  
**Continual Assessment – 2013**  
**Science**  
**Primary 3**

Name: \_\_\_\_\_ ( )

Class: Pr. 3 \_\_\_\_\_

Date: 30 August 2013

Time: 1 h 30 min

Science Teacher: \_\_\_\_\_

Parent's signature \_\_\_\_\_

|   |     |
|---|-----|
| Section A<br>(includes<br>Booklet K MCQs) | 60  |
| Section B                                 | 30  |
| Booklet K<br>(excludes MCQs)              | 10  |
| Total                                     | 100 |

**Section B (30 marks)**

For questions 31 to 40, write your answers in the spaces provided.

31. Study the classification diagram below.

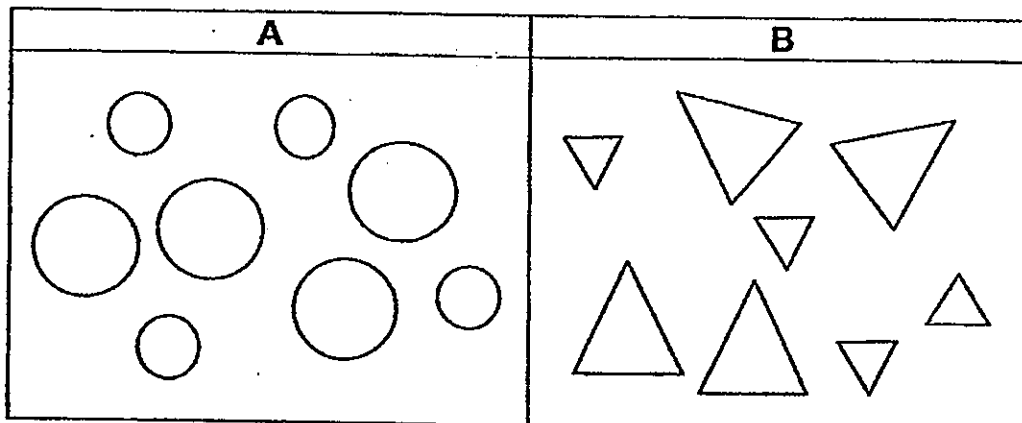

a) What characteristic is used to group the objects? (1 m)

\_\_\_\_\_

b) What characteristic can you use to group the objects in another way? (1 m)

\_\_\_\_\_

32. Mindy learnt about the following animals on a television programme.



dolphin



ant

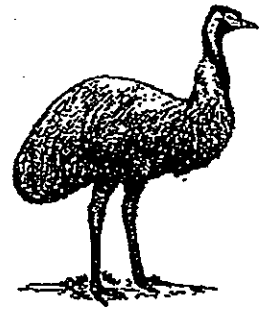

emu



grasshopper



chicken

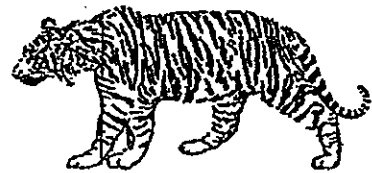

tiger

Classify the above animals into three equal groups, P Q and R, in the table below. (3 m)

| Animals |   |   |
|---------|---|---|
| P       | Q | R |
|         |   |   |
|         |   |   |

33. Alice and Ahmad observed the height of A and B over a period of four weeks. They recorded their observations in the table below.

|        | Height of A (cm) | Height of B (cm) |
|--------|------------------|------------------|
| Week 1 | 1                | 5                |
| Week 2 | 3                | 5                |
| Week 3 | 5                | 5                |
| Week 4 | 7                | 5                |

- (a) One of them is a living thing while the other is a non-living thing. Which is most likely a living thing, A or B? (1 m)

\_\_\_\_\_

- (b) From their observations in the table, state a characteristic of a living thing. (1 m)

\_\_\_\_\_

34. The diagram below shows an adult balsam plant. Write the correct names of the plant parts in the boxes, (i), (ii), (iii) and (iv). (2 m)

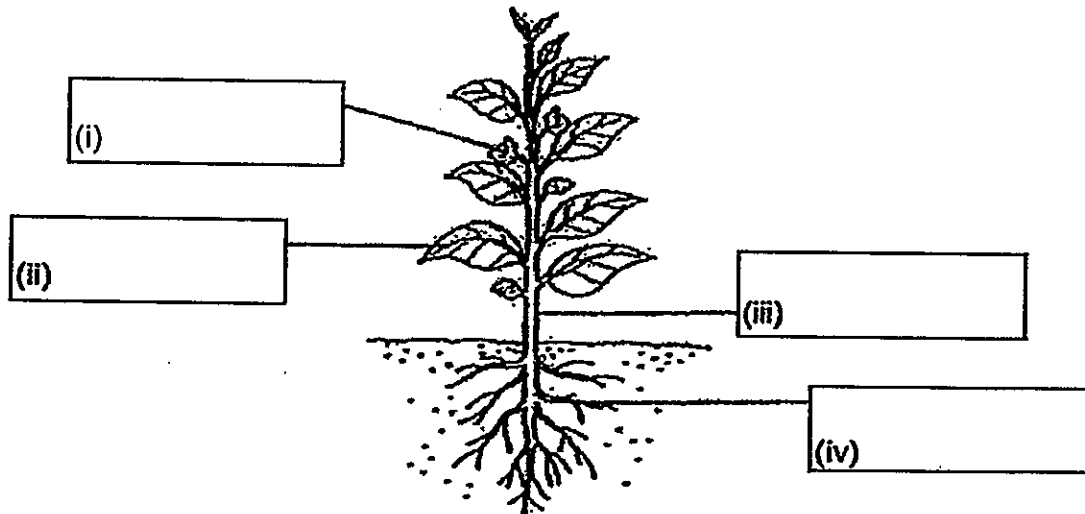

35. Janet placed two identical ring magnets through a wooden rod as shown in the diagram below.

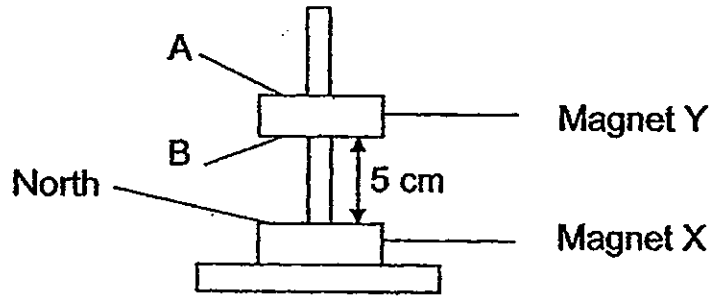

- (a) What magnetic poles are A and B? (1 m)

(i) A: \_\_\_\_\_

(ii) B: \_\_\_\_\_

- (b) She observed that Magnet Y was floating above Magnet X. Explain why Magnet Y was floating above Magnet X. (1 m)

---



---



---



---

- (c) Janet removed Magnet Y from the wooden rod and dropped it on the floor several times. When she placed Magnet Y back through the wooden rod, she observed that the distance between the two magnets decreased.

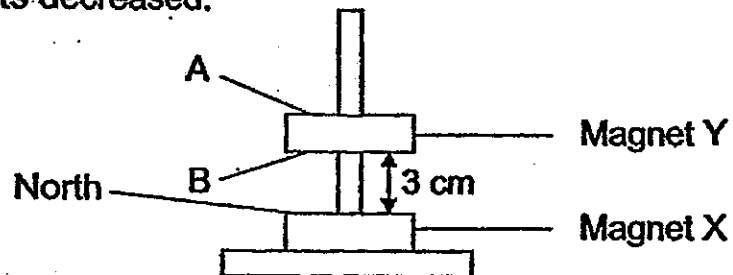

- State how dropping the magnet affects the strength of its magnetism. (1 m)

---



---

36. Tom carried out an experiment. He placed ten worms in the middle of a dish. Then he covered half the dish with dark paper and shone a bright light on the dish.

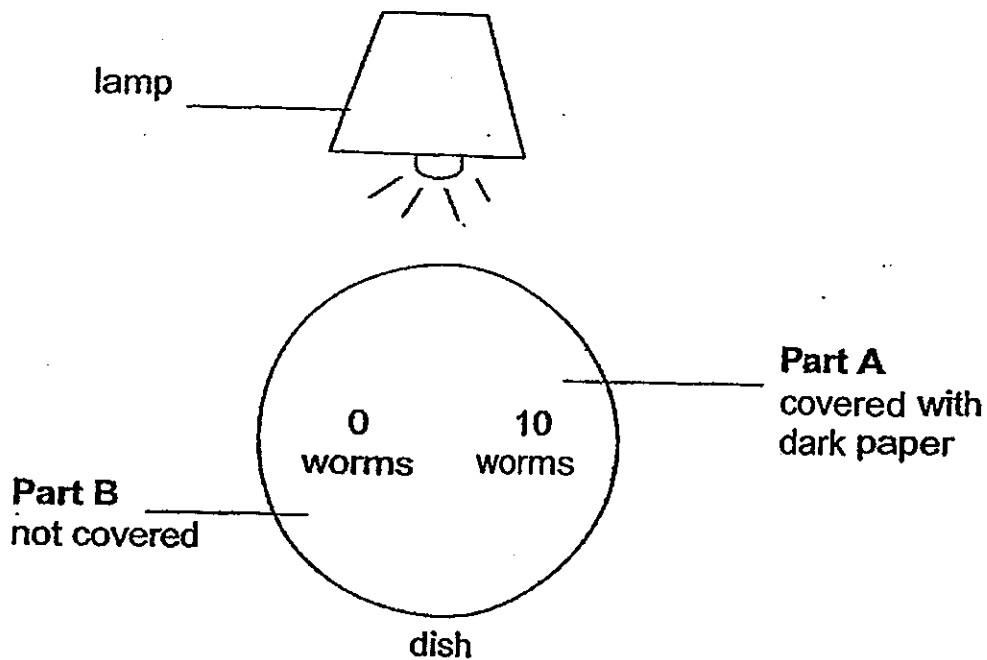

Twenty minutes later, Tom observed that all the worms were found in Part A of the dish.

- (a) Based on Tom's observations, state two characteristics of living things. (2 m)

- (i) \_\_\_\_\_  
(ii) \_\_\_\_\_

Tom covered the dish with a clear plastic wrap with holes in it. He observed that the worms died after a few days.

- (b) Give two reasons why the worms died. (2 m)

(i) Reason 1: \_\_\_\_\_

\_\_\_\_\_

(ii) Reason 2: \_\_\_\_\_

\_\_\_\_\_



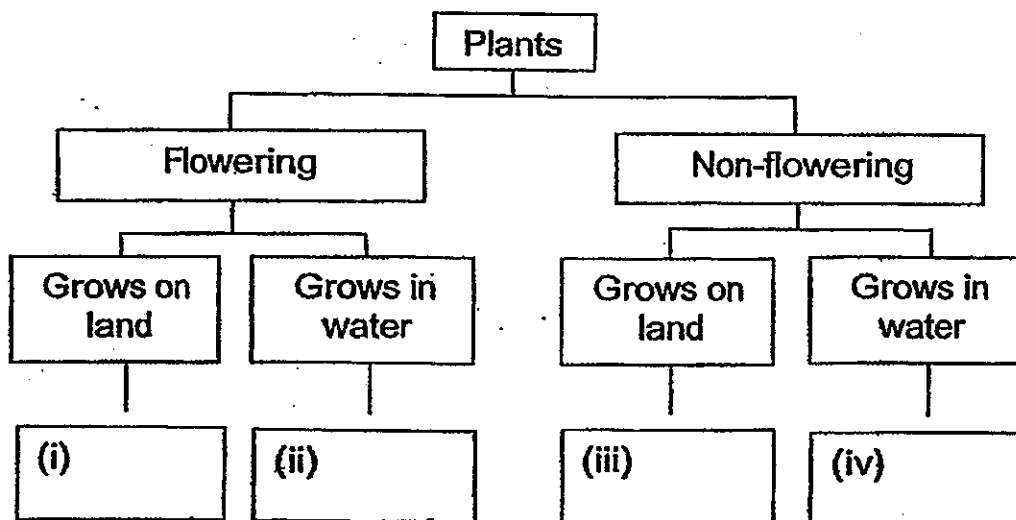

37. The table below shows the characteristics of four plants, P, Q, R and S.

| Characteristics | P | Q | R | S |
|-----------------|---|---|---|---|
| Bears fruit     |   | ✓ |   | ✓ |
| Grows on land   |   |   | ✓ | ✓ |
| Grows in water  | ✓ | ✓ |   |   |

(a) Classify the four plants in the chart below by writing P, Q, R and S in the correct boxes, (i), (ii), (iii) and (iv). (2 m)

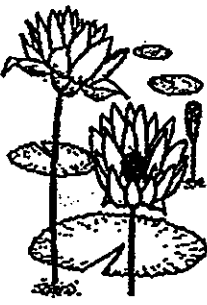

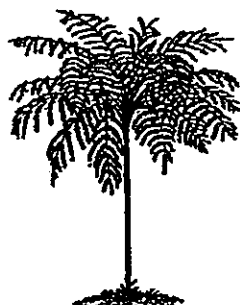
(b) Match the four plants below to Plants P, Q, R and S by writing P, Q, R and S in the correct boxes. (2 m)

| Water Lily  | Milkweed  | Tree Fern  | Floating Moss Fern  |
|---|---|--|---|
|  |  |  |  |
| (i)   | (ii)  | (iii)  | (iv)  |

38. Study the list of objects below.

|              |                |             |
|--------------|----------------|-------------|
| shoe lace    | telephone wire | rubber hose |
| leather belt | wooden pencil  | flag pole   |

(a) Group the objects under the correct headings in the table below. (3 m)

| Objects  |       |
|----------|-------|
| Flexible | Stiff |
|          |       |
|          |       |
|          |       |
|          |       |
|          |       |
|          |       |

(b) Study the graph below. It shows the number of bricks that bags A, B, C and D can hold before breaking.

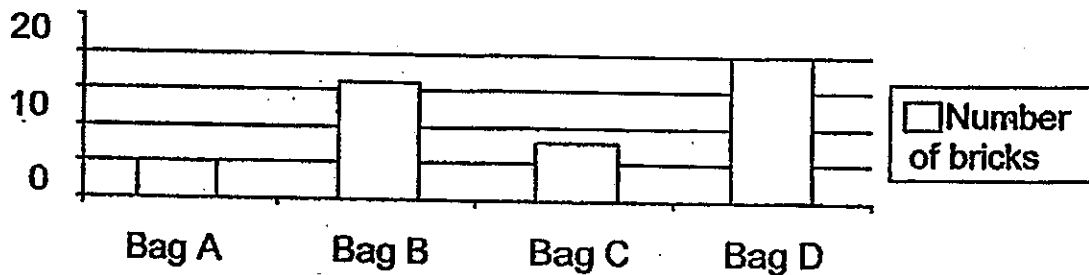

Arrange the bags according to their strength, starting from the strongest to the weakest. (1 m)

\_\_\_\_\_

strongest weakest



39. Study the flow chart below.

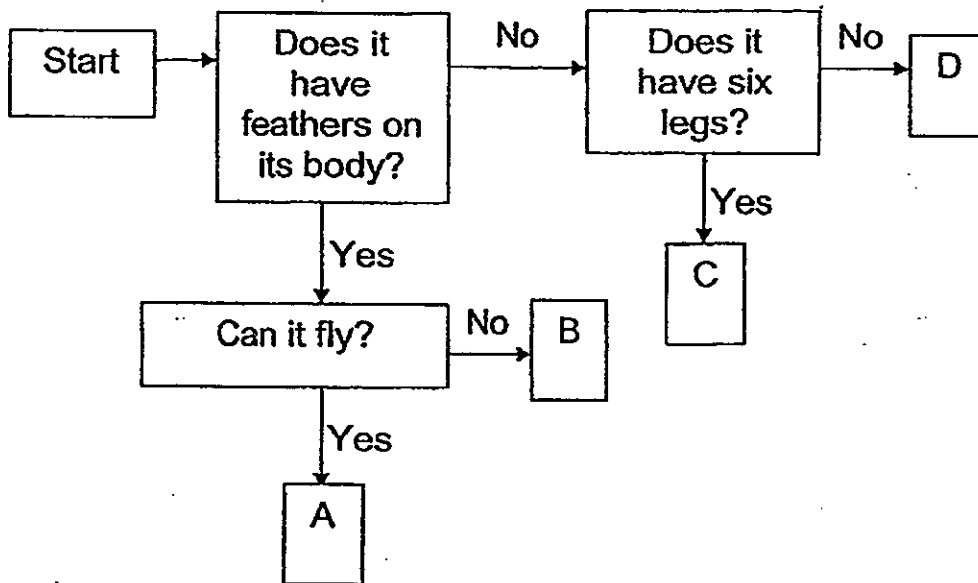

(a) Based on the chart, describe one similarity and one difference between Animal A and Animal B. (2 m)

(i) Similarity:

---



---

(ii) Difference:

---



---

b) Write the letters, A, B, C and D that represent the animals in the boxes below. (2 m)

|       |           |  |
|-------|-----------|--|
| (i)   | cockroach |  |
| (ii)  | hamster   |  |
| (iii) | penguin   |  |
| (iv)  | parrot    |  |

40. Jessie found Animal X in her garden. She made the following observations.

- It lays eggs near water plants!
- It has gills to help it breathe.
- It is a plant-eater.

(a) Based on the information above, what is the most likely body covering this animal has? (1 m)

---

(b) Which is the most likely group of animals that X belongs to? (1 m)

---

**For Questions 41—44, please refer to Booklet K.**

**End of Section B**

# ANSWER SHEET

**EXAM PAPER 2013**

**SCHOOL : PEI CHUN PUBLIC SCHOOL**

**SUBJECT : PRIMARY 3 SCIENCE**

**TERM : CA2**

---

|    |    |    |    |    |    |    |    |    |     |     |     |     |     |     |     |     |
|----|----|----|----|----|----|----|----|----|-----|-----|-----|-----|-----|-----|-----|-----|
| Q1 | Q2 | Q3 | Q4 | Q5 | Q6 | Q7 | Q8 | Q9 | Q10 | Q11 | Q12 | Q13 | Q14 | Q15 | Q16 | Q17 |
| 4  | 2  | 3  | 4  | 4  | 3  | 2  | 4  | 4  | 3   | 2   | 4   | 4   | 1   | 1   | 2   | 1   |

|     |     |     |     |     |     |     |     |     |     |     |     |     |
|-----|-----|-----|-----|-----|-----|-----|-----|-----|-----|-----|-----|-----|
| Q18 | Q19 | Q20 | Q21 | Q22 | Q23 | Q24 | Q25 | Q26 | Q27 | Q28 | Q29 | Q30 |
| 2   | 3   | 1   | 1   | 2   | 3   | 4   | 2   | NA  | NA  | NA  | NA  | NA  |

Section B

- Q31) a) Shape  
b) Size

NO ANSWER

Q32)

| Animals |             |         |
|---------|-------------|---------|
| P       | Q           | R       |
| Dolphin | Ant         | Emu     |
| Tiger   | Grasshopper | Chicken |

Q33) a) A

- b) Living things grow but non-living things do not grow

Q34) i) Flowers

- ii) leaves  
iii) stem  
iv) roots

- Q35) a) i) A: South  
 ii) B: North  
 b) Their like poles are facing each other thus they repel  
 c) Propping the magnet decreases its magnetism

- Q36) a) i) Living things move by themselves  
 ii) Living things respond to changes around them  
 b) i) Reason 1: The worms did not have food  
 ii) Reason 2: The worms did not have water

- Q37) a) i) S  
 ii) Q  
 iii) R  
 iv) P  
 b) i) Q  
 ii) S  
 iii) R  
 iv) P

Q38) a)

| Objects        |               |
|----------------|---------------|
| Flexible       | Stiff         |
| Shoe lace      | Wooden pencil |
| Telephone wire | Flag pole     |
| Rubber hose    |               |
| Leather belt   |               |

b) D, B, C, A

- Q39) a) i) A and B have feather on their body  
 ii) B cannot fly but A can fly  
 b) i) C  
 ii) D  
 iii) B  
 iv) A

- Q40) a) Scales  
 b) Fish

**Part I (10 MARKS)**

For each question from 1 to 10, four options are given. One of them is the correct answer. Make your choice (1, 2, 3 or 4) and write the correct answer in the brackets provided. Each correct answer will score one mark.

1. Which one of the following systems enables the human body to transport oxygen, digested food and water to all parts of the body?

(1)

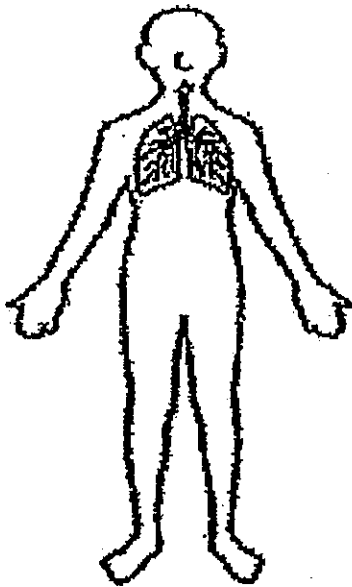

(2)

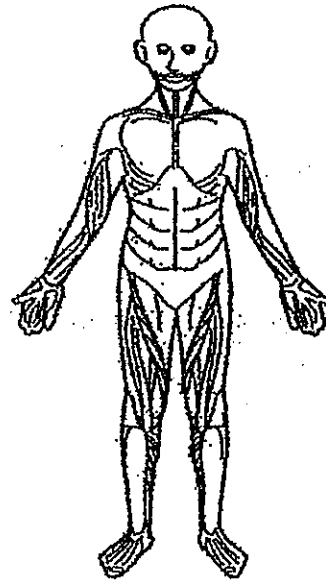

(3)

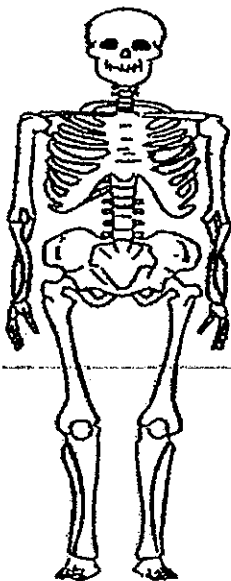

(4)

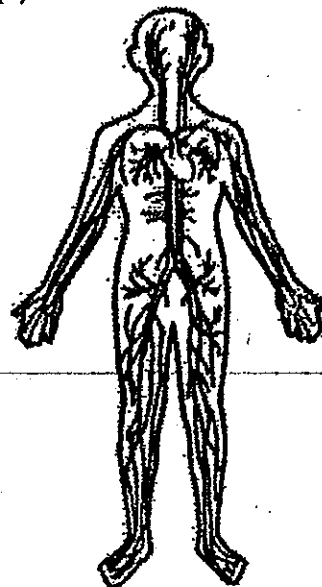

( )

2. Which one of the following organs is not part of the human skeletal system?
- (1) ribs (2) skull  
 (3) muscles (4) backbone ( )

3. The flowchart below shows the characteristics of some body systems.

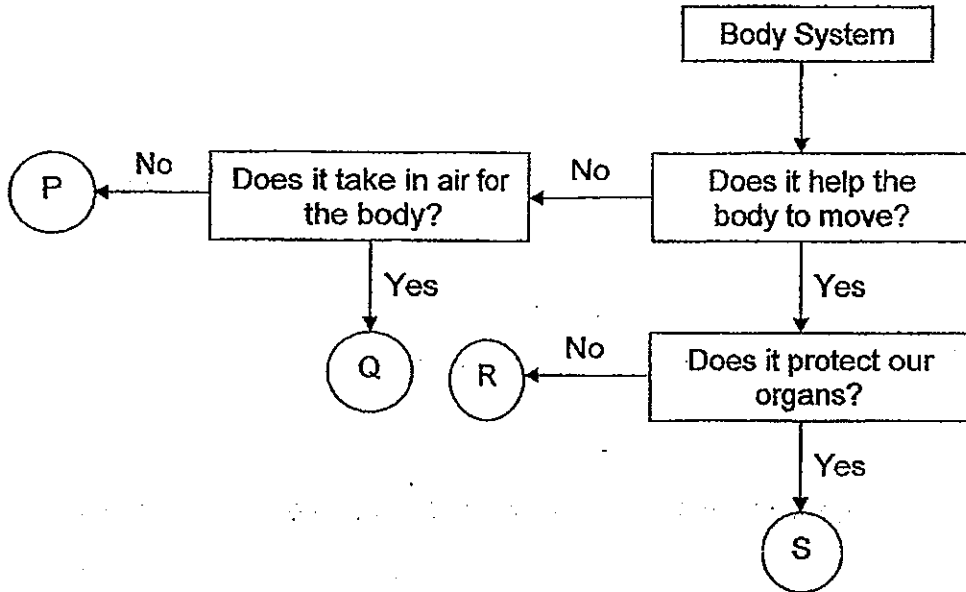

Which one of the following is likely to be the respiratory system?

- (1) P (2) Q  
 (3) R (4) S ( )

4. Which of the following statements about digestion are true?

- A : Digestion ends at the anus.  
 B : Digestion begins in the mouth.  
 C : Digestive juices in the large intestine help to break down the food.  
 D : Completely digested food passes through the walls of the small intestine and enters the bloodstream.

- (1) A and C only (2) A and D only  
 (3) B and C only (4) B and D only ( )

5. The diagram below shows a human digestive system.

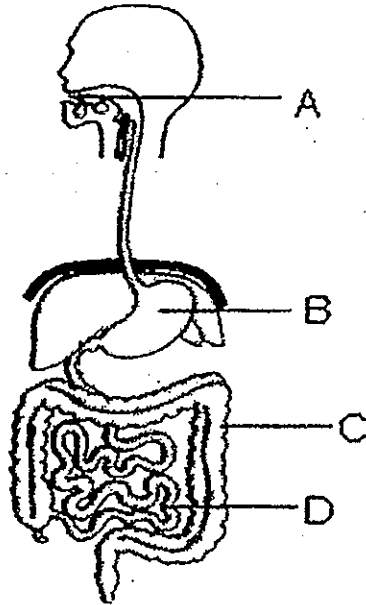

At which part of the human digestive system is water mostly absorbed from the undigested food?

- (1) A (2) B  
 (3) C (4) D ( )

6. Study the diagram below which shows a part of a digestive system.

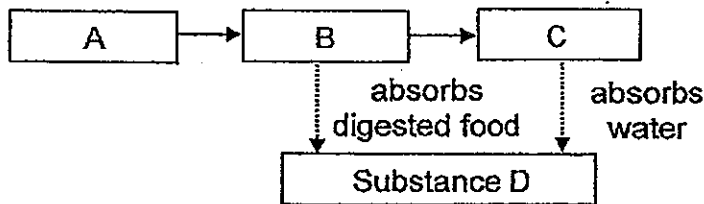

Which of the following represents A, B, C and D?

|     | A       | B               | C               | D               |
|-----|---------|-----------------|-----------------|-----------------|
| (1) | gullet  | stomach         | small intestine | blood           |
| (2) | gullet  | small intestine | blood           | small intestine |
| (3) | stomach | small intestine | large intestine | blood           |
| (4) | stomach | small intestine | blood           | large intestine |

( )

7. Study the pictures as shown below.

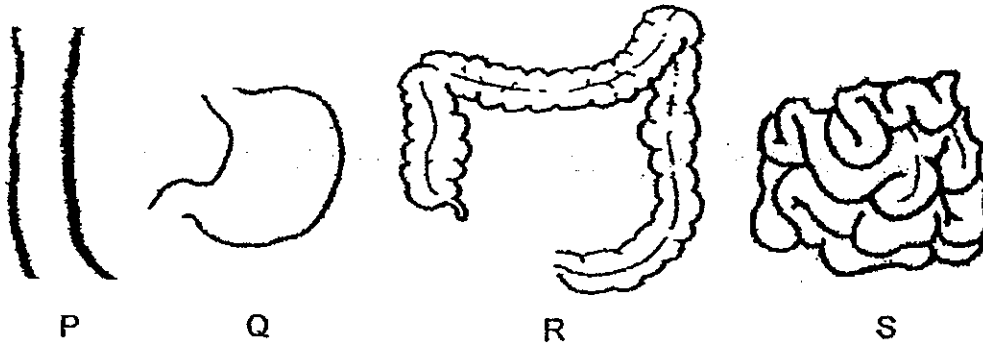

Which organ (P, Q, R or S) is not doing its function well, when someone is having constipation?

- (1) P (2) Q  
(3) R (4) S ( )

8. A magnet is placed in a basin of water. It is allowed to come to rest freely.

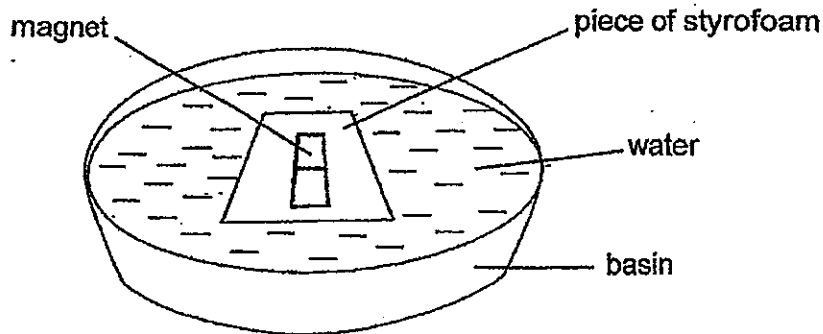

In which direction will the magnet come to a rest?

- (1) North - South (2) North - East  
(3) East - West (4) South - West ( )



9. Issac magnetised four iron nails (P, Q, R and S) using the 'stroking' method. Then he placed the iron nails in a box filled with paper clips to test the strength of the magnetised iron nails. The results are as shown below.

| Iron Nail | Number of strokes applied | Number of paper clips attracted |
|-----------|---------------------------|---------------------------------|
| P         | 4                         | 1                               |
| Q         | 8                         | 2                               |
| R         | 16                        | 4                               |
| S         | 28                        | 8                               |

What can Issac infer from the experiment?

- (1) The strength of the four iron nails are the same.
- (2) The more strokes applied to the iron nail, the weaker the iron nail.
- (3) The more strokes applied to the iron nail, the stronger the iron nail.
- (4) The direction of strokes applied affects the strength of the iron nail.

( )

10. Joyce conducted an experiment as shown below to test the strength of four magnets (W, X, Y and Z).

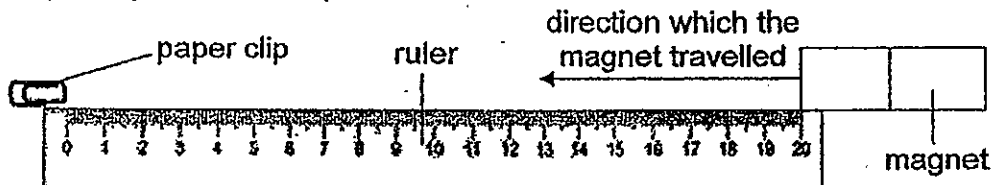

She recorded the results in a table as shown below.

| Magnet  | W    | X     | Y    | Z     |
|---|------|-------|------|-------|
| Furthest distance between the magnet and the paper clip when it attracts the paper clip | 5 cm | 14 cm | 8 cm | 10 cm |

Which one of the magnets is the strongest?

- (1) W
- (2) X
- (3) Y
- (4) Z

( )

**End of Part I**

**Part II (5 MARKS)**

For questions 11 and 12, write your answers in the blanks provided.

11. Joey classified the body parts of the human digestive system as shown below

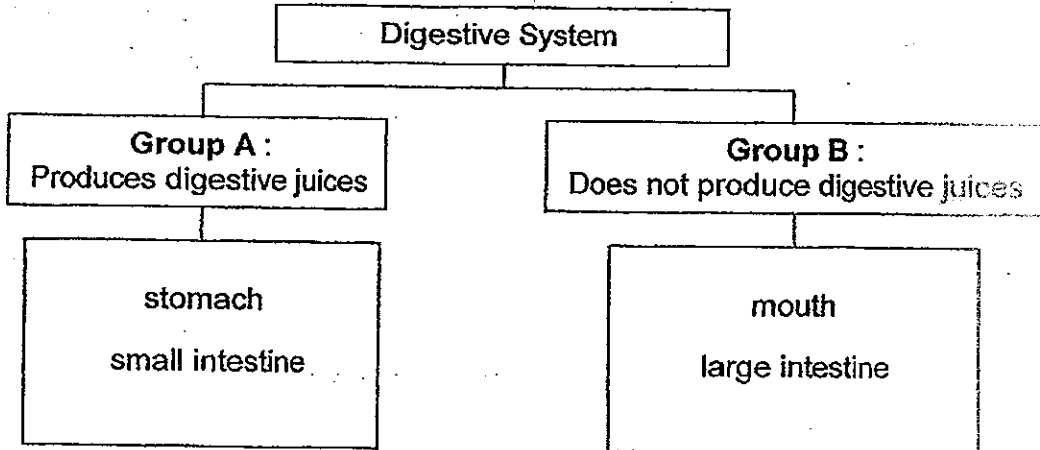

(a) Name the body part that has been classified wrongly. Explain why. (1m)

---



---

(b) Joey wanted to include 'gullet' into the chart above. Which group should 'gullet' be classified? Explain why. (1m)

---



---

(c) Joey wanted to include the body part 'windpipe' under Group A. Do you agree with him? Explain why. (1m)

---



---

12. Kelly arranged four ring magnets (A, B, C and D) in a set-up as shown below.

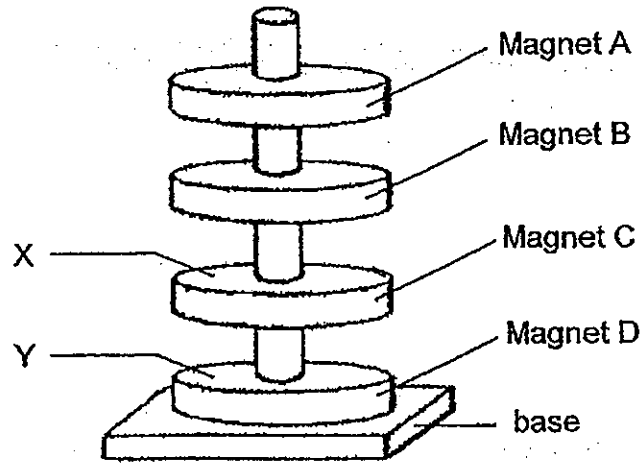

- (a) If X is the North Pole of Magnet C, what is the unknown pole Y of Magnet D? (1m)

Y : \_\_\_\_\_

- (b) The Magnet A is turned over in the above set-up. What would you observe? (1m)

---

---

**End of Part II**

# ANSWER SHEET

**EXAM PAPER 2013**

**SCHOOL : ROSYTH PRIMARY SCHOOL**

**SUBJECT : PRIMARY 3 SCIENCE**

**TERM : CA2 (Topical Test)**

---

| Q1 | Q2 | Q3 | Q4 | Q5 | Q6 | Q7 | Q8 | Q9 | Q10 |
|----|----|----|----|----|----|----|----|----|-----|
| 4  | 3  | 2  | 3  | 3  | 3  | 3  | 1  | 3  | 2   |

Part II

Q11

- a) The mouth. It produces digestive juices and therefore should not be in Group A.
- b) Group B. It does not produce digestive juices.
- c) No. Windpipe is part of the respiratory system and not the digestive system

Q12

- a) Y: South
- b) Magnet B will be attracted to Magnet A and the rest will stay the same

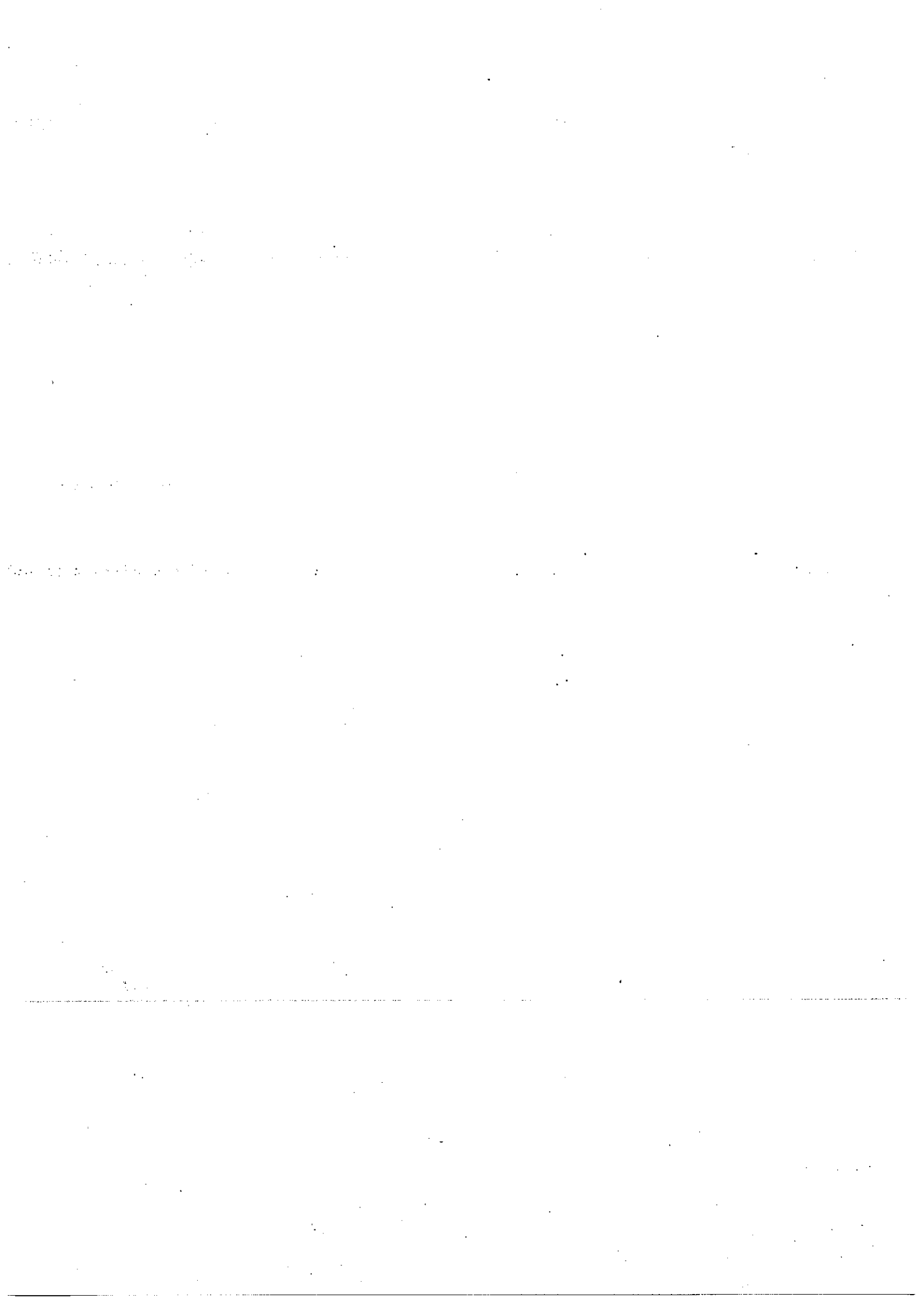

ANGLO-CHINESE SCHOOL  
(JUNIOR)



SEMESTRAL ASSESSMENT 1 (2013)  
PRIMARY 3

SCIENCE

BOOKLET A

Friday

10 May 2013

1 hour 30 minutes

Name : \_\_\_\_\_ ( )

Class : P3 \_\_\_\_\_

**INSTRUCTIONS TO PUPILS**

**DO NOT TURN OVER THE PAGES UNTIL YOU ARE TOLD TO DO SO**

Follow all instructions carefully.

There are 25 questions in this booklet.

Answer **ALL** questions.

**INFORMATION FOR PUPILS**

The total marks for this booklet is 50.

The total time for Booklets A and B is 1 hour 30 minutes.

**This question paper consists of 13 printed pages. (Inclusive of cover page)**

**Section A (50 marks)**

For each question from 1 to 25, four options are given. One of them is the correct answer. Choose the correct option (1, 2, 3 or 4) and shade the correct oval on the Optical Answer Sheet (OAS).

1 Study the classification chart below.

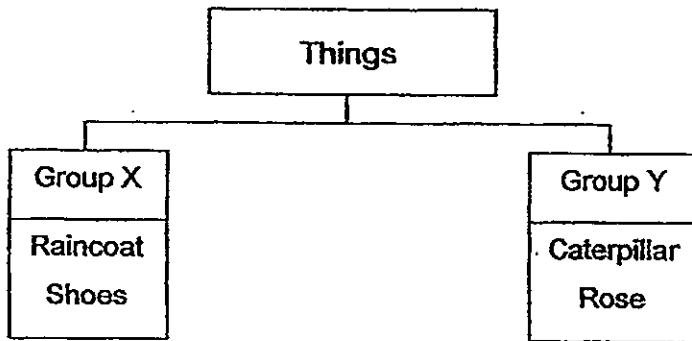

Which of the following things are best classified under Groups X and Y respectively?

|     | Group X  | Group Y    |
|-----|----------|------------|
| (1) | Fern     | Pencil     |
| (2) | Mushroom | Cat        |
| (3) | Sofa     | Crocodile  |
| (4) | Car      | Teddy Bear |

2 Which of the following set of shapes is not grouped by the number of corners?

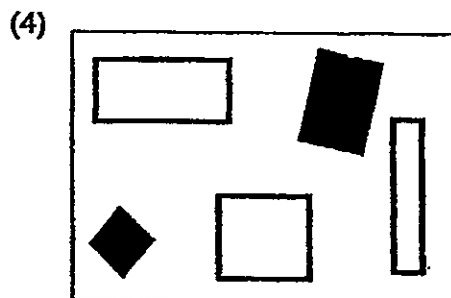
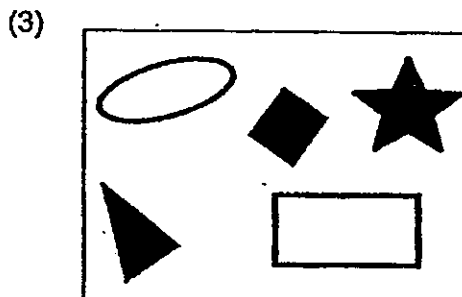
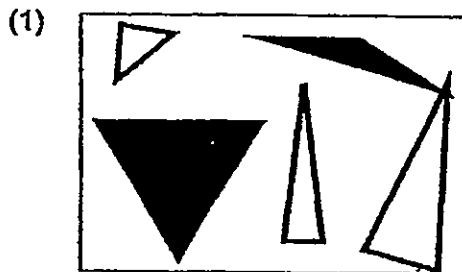

3 Study the classification table below.

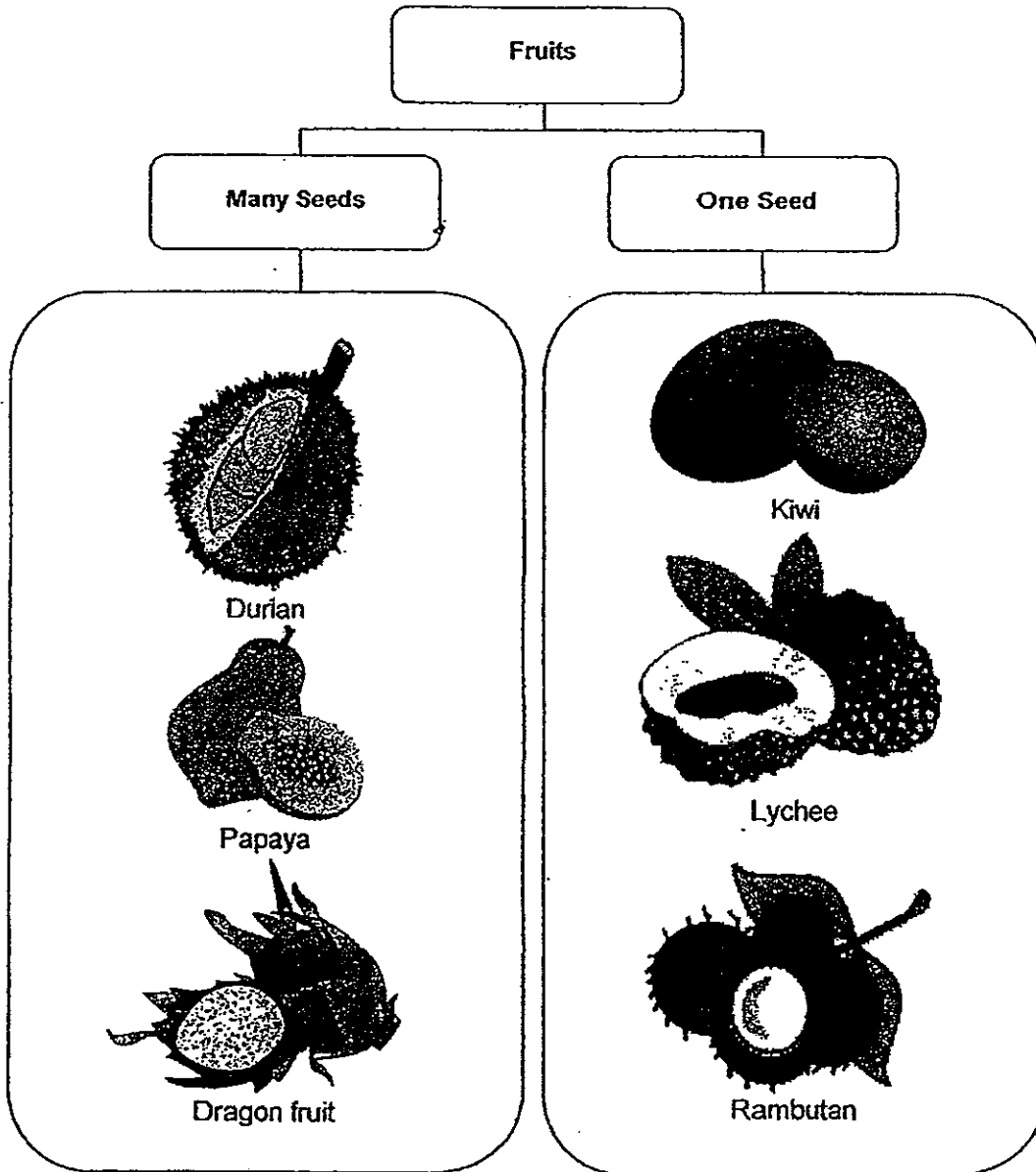

Which fruit has been classified wrongly?

- (1) Kiwi
- (2) Durian
- (3) Papaya
- (4) Rambutan



4 Other than air, all living things need \_\_\_\_\_ to survive.

- A food
- B water
- C sunlight

- (1) A and B only
- (2) A and C only
- (3) B and C only
- (4) A, B and C

5 The diagram below shows that the adult frog can \_\_\_\_\_.

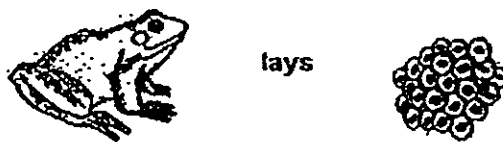

- (1) grow
- (2) reproduce
- (3) respond to changes
- (4) move by themselves

6 Aston classified the leaves into 2 groups as shown below.

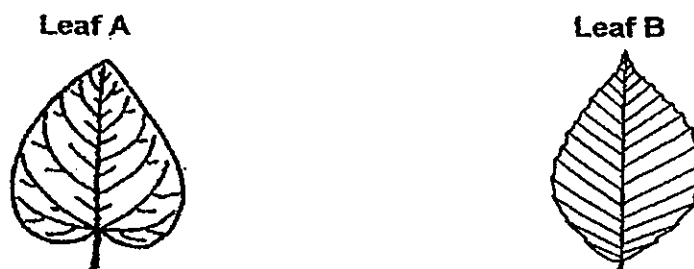

Which of the following best describes the shape of each leaf?

|     | Leaf A | Leaf B |
|-----|--------|--------|
| (1) | oval   | round  |
| (2) | palm   | heart  |
| (3) | heart  | oval   |
| (4) | round  | heart  |

7 Study the objects below.



A: Seedling



B. Aeroplane

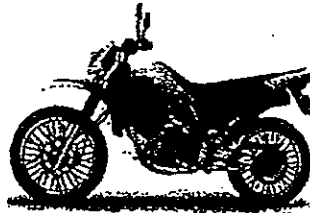

C. Motorcycle



D: Centipede

Which of these objects can move by itself / themselves?

- (1) D only
- (2) A and D only
- (3) B and C only
- (4) A, B, C and D

8 Three boys, James, Ken and Lance, studied the classification table below.

| Have wings | Have fins | Have 6 legs | Have hair on their body |
|------------|-----------|-------------|-------------------------|
| Ostrich    | Goldfish  | Damselfly   | Bat                     |
| Sparrow    | Shark     | Mosquito    | Human                   |







They then made the following statements:

- James: The table shows that an ostrich and sparrow can fly.  
Ken: The table shows that animals are grouped according to their common characteristics.  
Lance: The table shows that animals are grouped according to the way they move.

Who made the correct statement(s)?

- (1) Ken only
- (2) Lance only
- (3) James and Ken only
- (4) James and Lance only

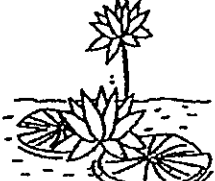
9 A florist classified some flowers into two groups as shown below.

| Group 1   | Group 2   |
|---|---|
|  <p data-bbox="231 645 343 676">Flower Q</p>  <p data-bbox="510 645 630 676">Flower R</p>  <p data-bbox="399 907 510 938">Flower S</p> |  <p data-bbox="821 660 933 692">Flower T</p>  <p data-bbox="1069 660 1189 692">Flower U</p>  <p data-bbox="933 907 1045 938">Flower V</p> |

Which flower has been put into the wrong group?

- (1) Flower R
- (2) Flower S
- (3) Flower T
- (4) Flower U

10 The diagrams below show different types of trees. Which tree is able to provide the least shade?

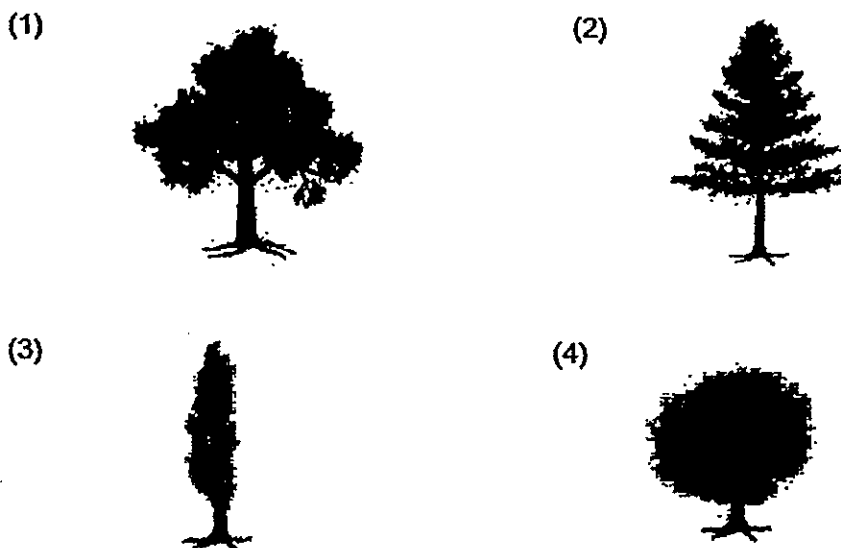

11 The diagram shows a plant.

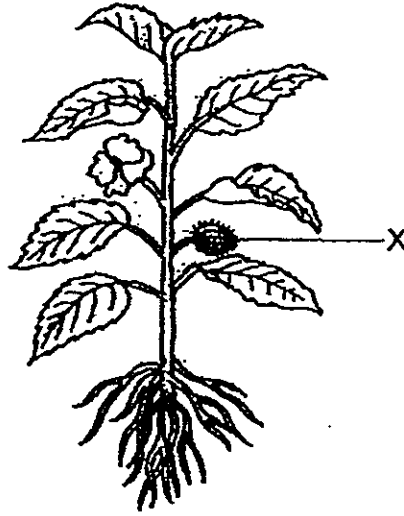

Identify the plant part X.

- (1) root
- (2) fruit
- (3) leaf
- (4) stem

12 The diagrams below show some leaves.

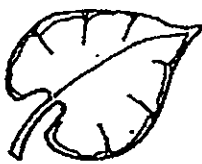

A



B



C

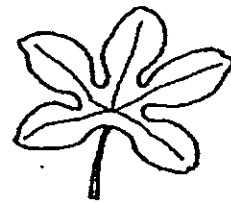

D

Which of these leaves has jagged edges?

- (1) A
- (2) B
- (3) C
- (4) D

- 13 The diagram below shows a plant grown in a garden.

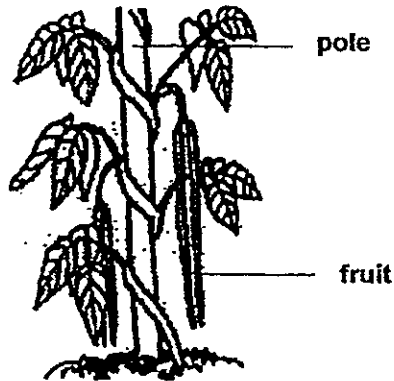

Which of the following is/are true about the plant shown?

- A It has no roots.
- B It has a weak stem.
- C It is a flowering plant.

- (1) B only
- (2) A and B only
- (3) B and C only
- (4) A, B and C

- 14 Which of the following plants give off a sweet smell?

- A Rose
- B Jasmine
- C Rafflesia

- (1) A only
- (2) A and B only
- (3) B and C only
- (4) A, B and C

- 15 Mr Ali bought 2 pots of plants of the same type and size. He removed all the leaves on Plant B. He watered both plants with the same amount of water daily and left them in the garden.

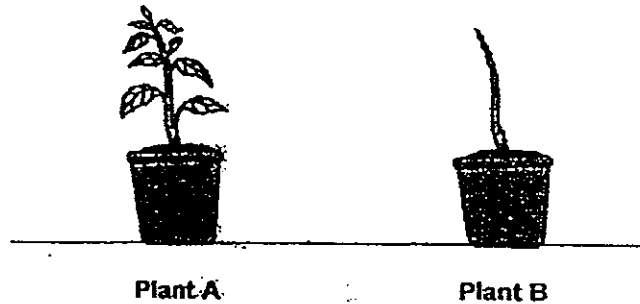

A week later, Mr Ali noticed that plant B had dried up while plant A was growing well. This shows that plants need \_\_\_\_\_.

- (1) air to live
  - (2) sunlight to grow
  - (3) water to survive
  - (4) leaves to make food
- 16 Which of the following plants can be used to make food for Man?
- A jasmine
  - B allamanda
  - C chrysanthemum
- (1) A and B
  - (2) A and C
  - (3) B and C
  - (4) A, B and C

17 Observe the animal in the picture below.



Which part of its body does it use to eat?

- (1) legs
- (2) beak
- (3) wings
- (4) feathers

18 Isaac found some animals in the eco-garden. His brother told him that they were fish. To find out if his brother was right, Isaac decided to observe:

- A what they eat
- B type of outer coverings they have
- C the parts of the body that help them move

Which of the above will help him decide if the animals are really fish?

- (1) A and B only
- (2) A and C only
- (3) B and C only
- (4) A, B and C

19 Study the flow chart below carefully.

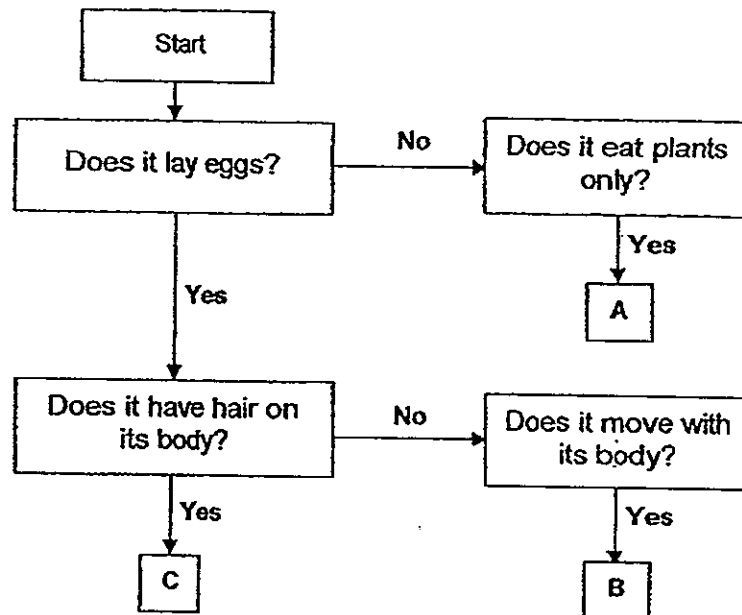

Which of the following best represent A, B and C respectively?

|     | A        | B        | C        |
|-----|----------|----------|----------|
| (1) | Mouse    | Dolphin  | Cat      |
| (2) | Zebra    | Snake    | Platypus |
| (3) | Cat      | Platypus | Mouse    |
| (4) | Platypus | Snake    | Dolphin  |

20 Which of the following statements is true about living things responding to changes in their surrounding?

- (1) A hen laying eggs.
- (2) A tadpole growing into a frog.
- (3) A horse giving birth to its young.
- (4) A millipede coiling itself when someone touches it.



21 Some animals are classified into two groups as shown below.

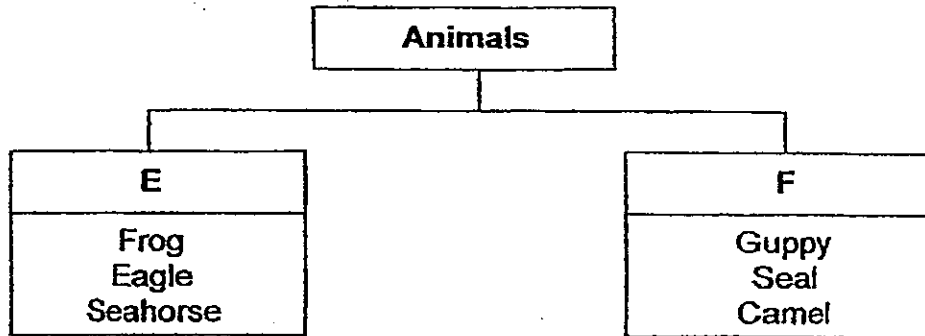

Which of the following sets of sub-heading is correct?

|     | E                              | F                                     |
|-----|--------------------------------|---------------------------------------|
| (1) | Fish                           | Mammals                               |
| (2) | Plant-eaters                   | Animal-eaters                         |
| (3) | Animals that live in the water | Animals that live on land             |
| (4) | Animals that lay eggs          | Animals that give birth to live young |

22 Arjun conducted the following experiment.

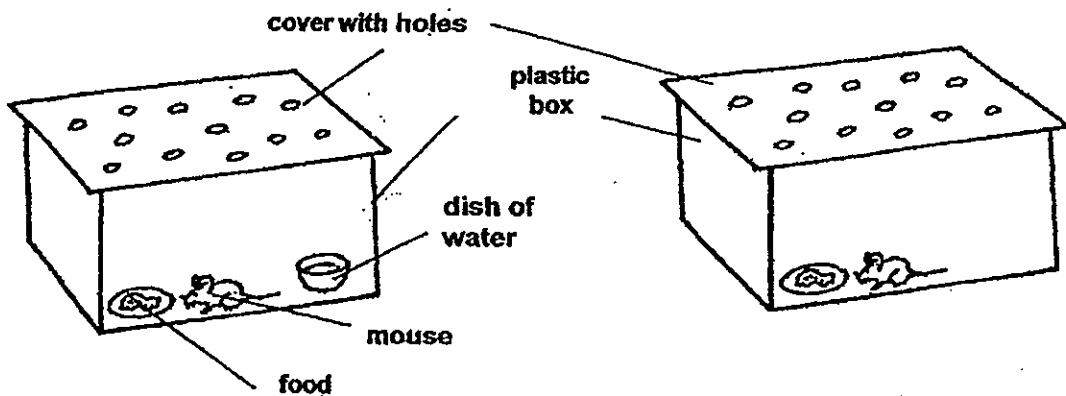

Based on the above experiment, Arjun wanted to find out if the mouse needs \_\_\_\_\_ to survive.

- (1) air
- (2) food
- (3) water
- (4) a box

23 Which of these is not an insect?

(1)

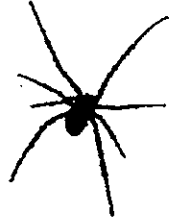

(2)



(3)

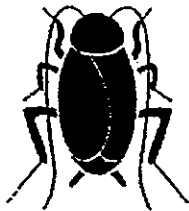

(4)



24 The diagram below shows a seagull.



The main reason why the seagull is a bird is because it \_\_\_\_\_.

- (1) can fly
- (2) lays eggs
- (3) has wings
- (4) has feathers

25 A fish and a house lizard may be put in the same group because they \_\_\_\_\_.

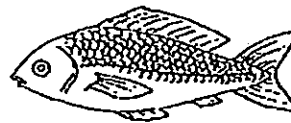

- (1) have a slimy body
- (2) live in the same place
- (3) move in the same way
- (4) have similar outer coverings

ANGLO-CHINESE SCHOOL  
(JUNIOR)



SEMESTRAL ASSESSMENT 1 (2013)  
PRIMARY 3

SCIENCE

BOOKLET B

Friday

10 May 2013

1 hour 30 minutes

Name : \_\_\_\_\_ ( )

Class : P3\_\_

**INSTRUCTIONS TO PUPILS**

**DO NOT TURN OVER THE PAGES UNTIL YOU ARE TOLD TO DO SO**

Follow all instructions carefully.

There are 14 questions in this booklet.

Answer **ALL** questions.

**INFORMATION FOR PUPILS**

The number of marks is given in brackets [ ] at the end of each question or part question.

The total marks for this booklet is 40.

The total time for Booklets A and B is 1 hour 30 minutes.

**This question paper consists of 13 printed pages. (Inclusive of cover page)**

|                           |     |
|---------------------------|-----|
| BOOKLET A                 | 150 |
| BOOKLET B                 | 140 |
| TOTAL                     | 90  |
| Parent's signature/ Date: |     |

**Section B (40 marks)**

For questions 26 to 39, write your answers in this booklet. The number of marks available is shown in the brackets [ ] at the end of each question or part question.

26 Observe the two things below.

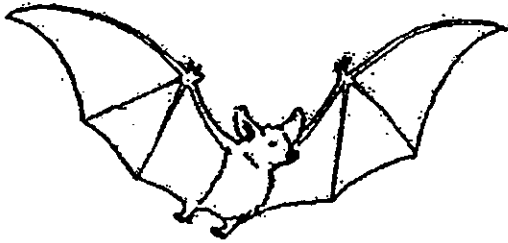

Thing Q

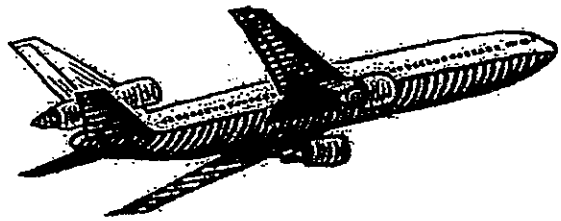

Thing R

(a) Based on what you can see, state one similarity between the two things. [1]

---

(b) State two differences between the two things. (Do not compare size) [2]

---

---

---

---

|  |
|--|
|  |
|--|

27 Study the classification chart below.

| Animals      |           |
|--------------|-----------|
| Group A      | Group B   |
| Blue whale   | Clownfish |
| Hippopotamus | Peacock   |

(a) State one way in which the above animals are grouped. [1]

---

---

(b) Some male animals, like the peacock, are more colourful than the female animal, the peahen.

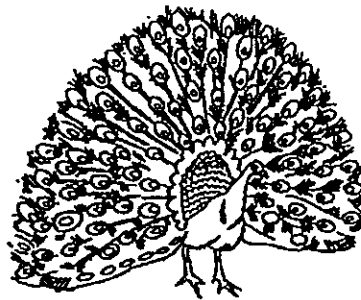

peacock

How is this useful to the male peacock? [1]

---

---

(c) Compare the outer coverings of the clownfish and the peacock. Name one difference in their outer coverings. [1]

---

---

|  |
|--|
|  |
|--|

28 Study the classification chart below.

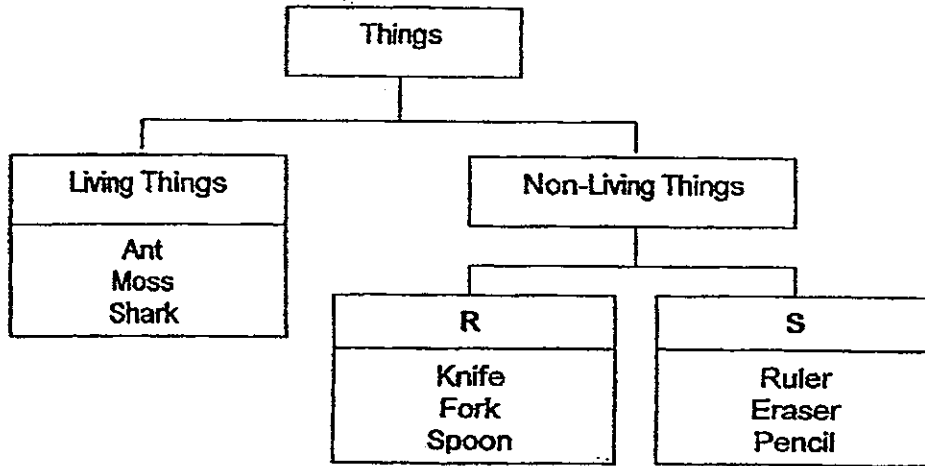

(a) Give appropriate sub-headings to the above classification chart. [1]

R: \_\_\_\_\_

S: \_\_\_\_\_

(b) In which group (R or S), would you classify a plate? [1]

\_\_\_\_\_

29 Alex has some guppies, water plants and tubifex worms in his fish tank. He observed them for four weeks and recorded his observation as shown in the table below.

| Type of living thing | Number of living things at the end of |        |        |        |
|----------------------|---------------------------------------|--------|--------|--------|
|                      | Week 1                                | Week 2 | Week 3 | Week 4 |
| Guppies              | 4                                     | 4      | 5      | 7      |
| Worms                | 80                                    | 55     | 30     | 5      |
| Water plant          | 6                                     | 6      | 6      | 6      |

(a) Based on the results of Alex's experiment, what could he infer about the diet of the guppies? Circle the correct answer. [1]

plant eater

meat eater

plant and meat-eater

(b) Based on the results of Alex's experiment, state one characteristic of living things shown by the guppies. [1]

\_\_\_\_\_

|  |
|--|
|  |
|--|

30 The classification chart below shows how some fruits are grouped.

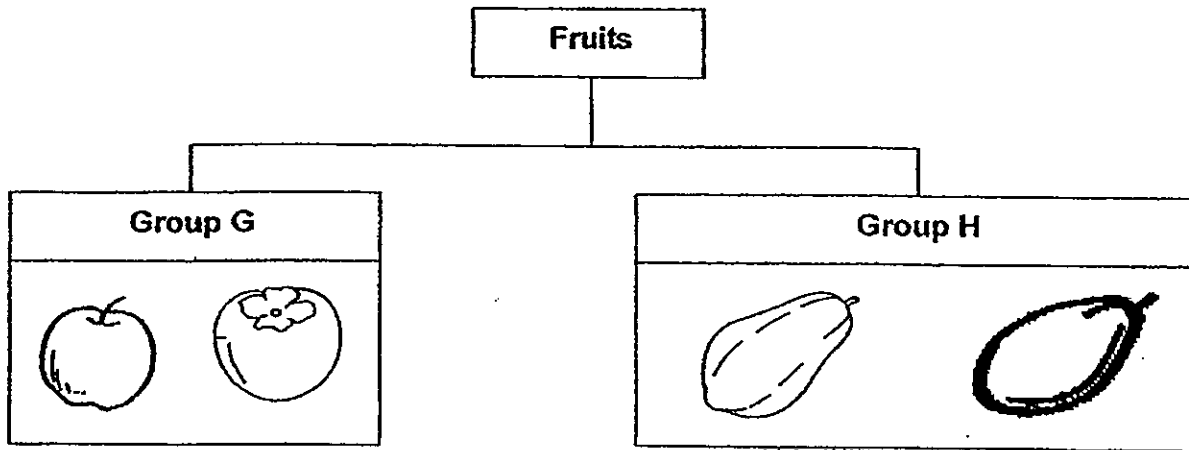

(a) How are the fruits in Group H similar in terms of shape? [1]

---

(b) In which group would you put an orange? [1]



---

(c) Explain your choice in (b) [1]

---

|  |
|--|
|  |
|--|

31 Study the flow chart about animals below.

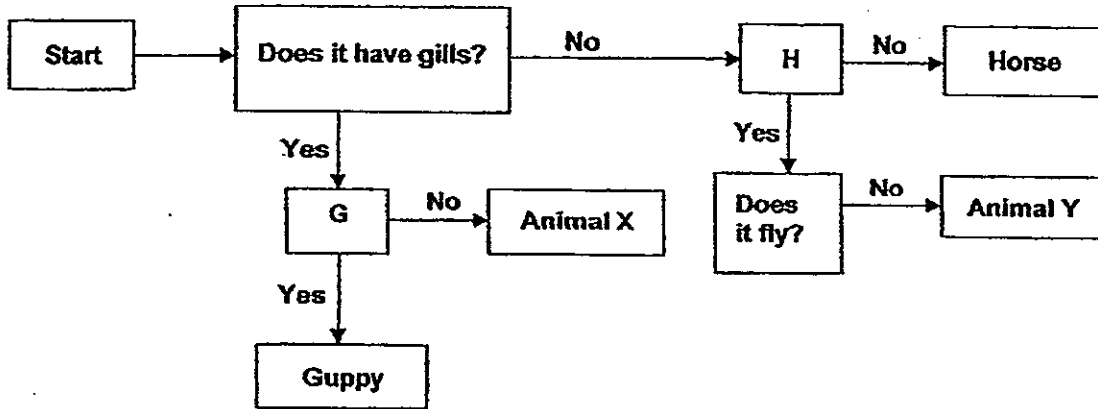

The letters, G and H, in the chart represent questions that help to classify the animals. Write the letters, G and H, in the correct boxes below to indicate the question they represent. Each letter can only be used once. [1]

| Question                               | Letter |
|--|--------|
| Does it lay eggs?                      |        |
| Does it give birth to its young alive? |        |

(b) Based on the above information, state all the characteristics of Animal Y. [1]



---



---

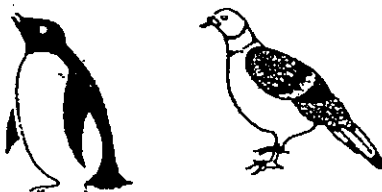

32 The pictures below show how Arthur classified some animals.

| Group J   | Group K  |
|---|--|
|  |  |

(a) Write suitable headings for Group J and Group K. [1]

Group J: \_\_\_\_\_  
 Group K: \_\_\_\_\_



(b) (i) What kind of outer covering do the animals in Group J have? [1]

\_\_\_\_\_

(ii) State one use of the outer covering of the animals in Group J. [1]

\_\_\_\_\_  
 \_\_\_\_\_

(c) Arthur reclassified the animals into 2 other groups as shown below.

| Group L   | Group M  |
|---|--|
|  |  |

State the characteristic which was used to regroup the animals. [1]

\_\_\_\_\_  
 \_\_\_\_\_

33 The diagram below shows the various plants with pink flowers that Ivy saw in the garden.

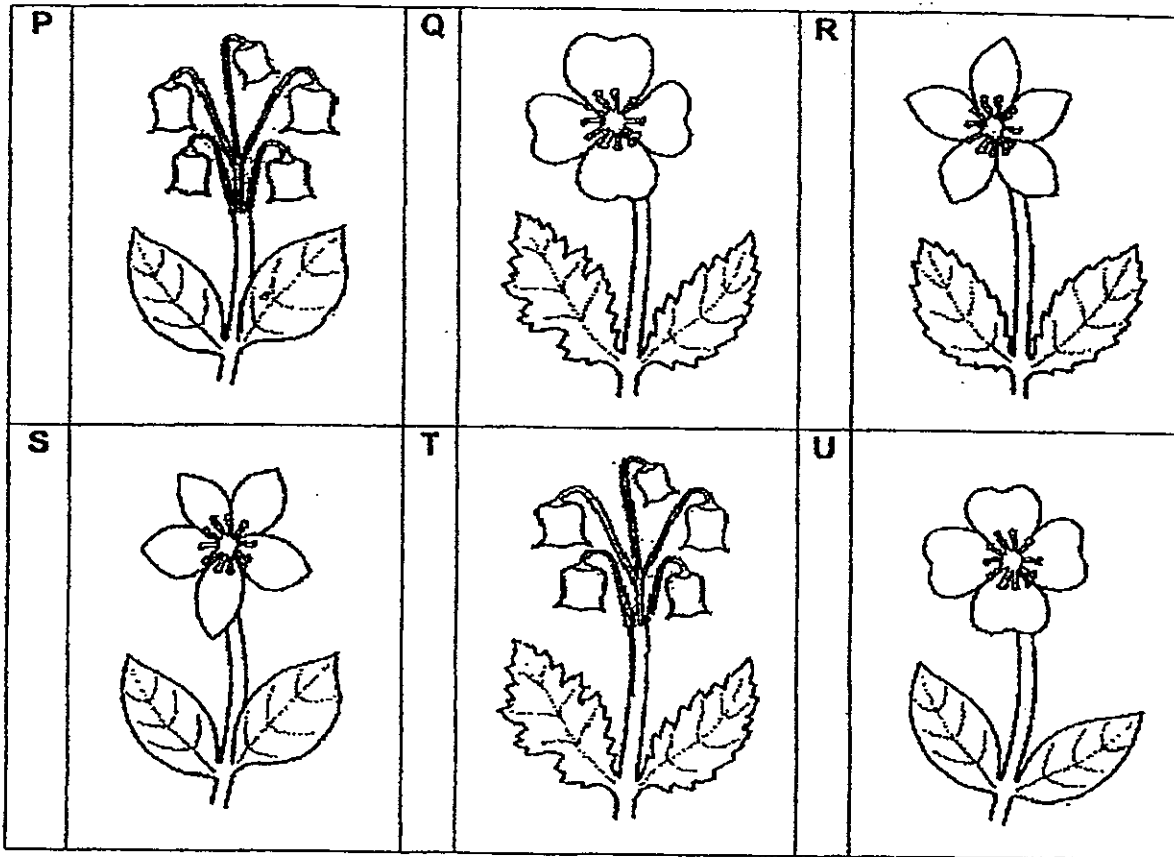

(a) Ivy wants to sort them into groups. Suggest two ways to sort these plants into two groups. [2]

Suggestion 1: \_\_\_\_\_  
 \_\_\_\_\_

Suggestion 2: \_\_\_\_\_  
 \_\_\_\_\_

(b) Mrs Ong's favourite plant has flowers in groups and leaves with jagged edges. Which plant (P, Q, R, S, T or U) is Mrs Ong's favourite plant? [1]

\_\_\_\_\_

(a) Complete the classification table below by placing the plants into the two groups. [2]

|      |        |       |      |               |
|------|--------|-------|------|---------------|
| Fern | Orchid | Ixora | Rose | Morning Glory |
|------|--------|-------|------|---------------|

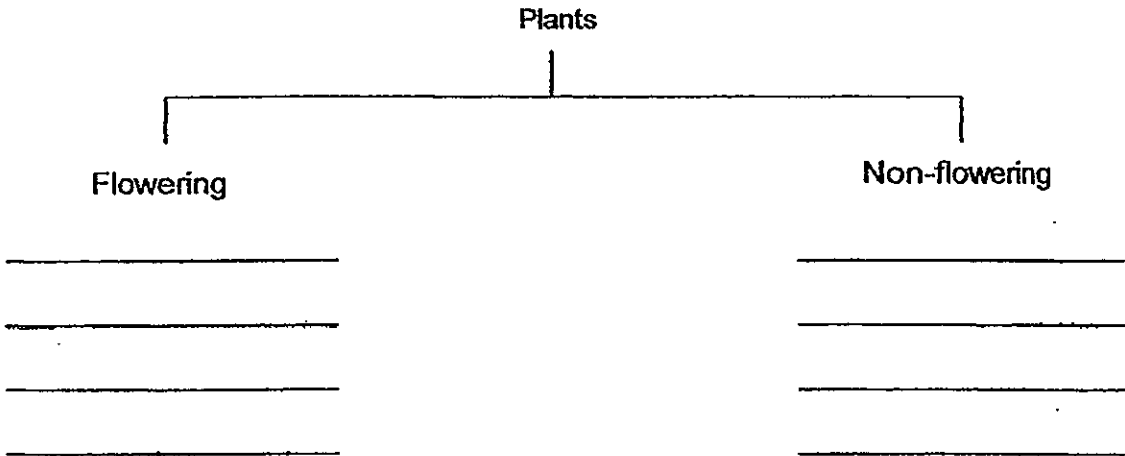

(b) Under which sub-heading should grass be categorised? [1]

\_\_\_\_\_

The diagram below shows different types of animals.

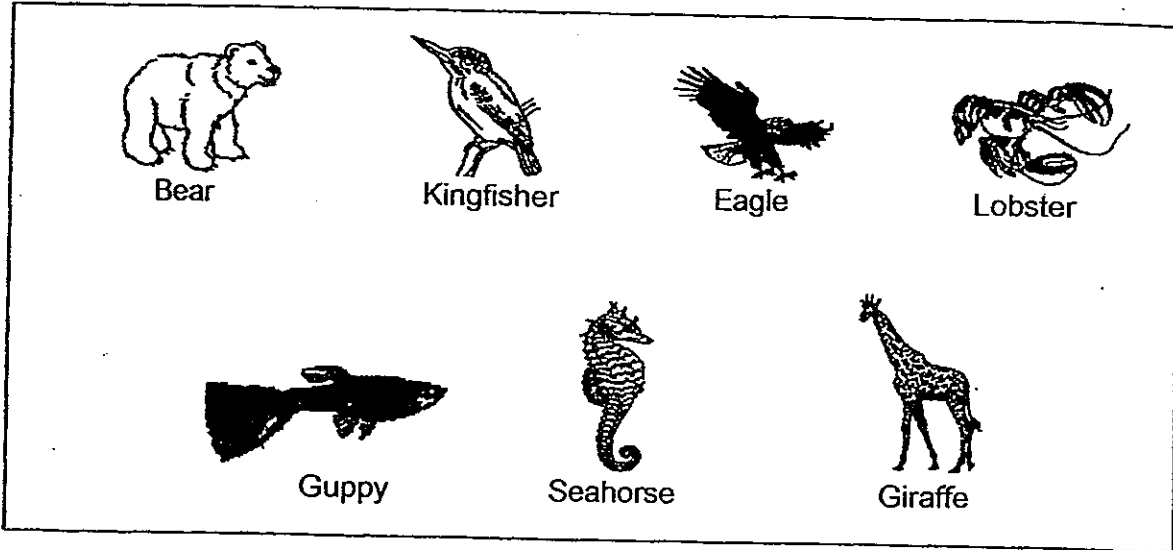

(a) Fill the classification table below with the animal names given above. [2]

| Outer coverings |          |      |       |
|-----------------|----------|------|-------|
| Scales          | Feathers | Y    | Shell |
|                 |          | Pony |       |
|                 |          |      |       |
|                 |          |      |       |

(b) Give a suitable heading for 'Y'. [1]

The flowchart below compares mammals and birds.

- (a) Fill in the boxes below with suitable words to show how mammals and birds are different. [2]

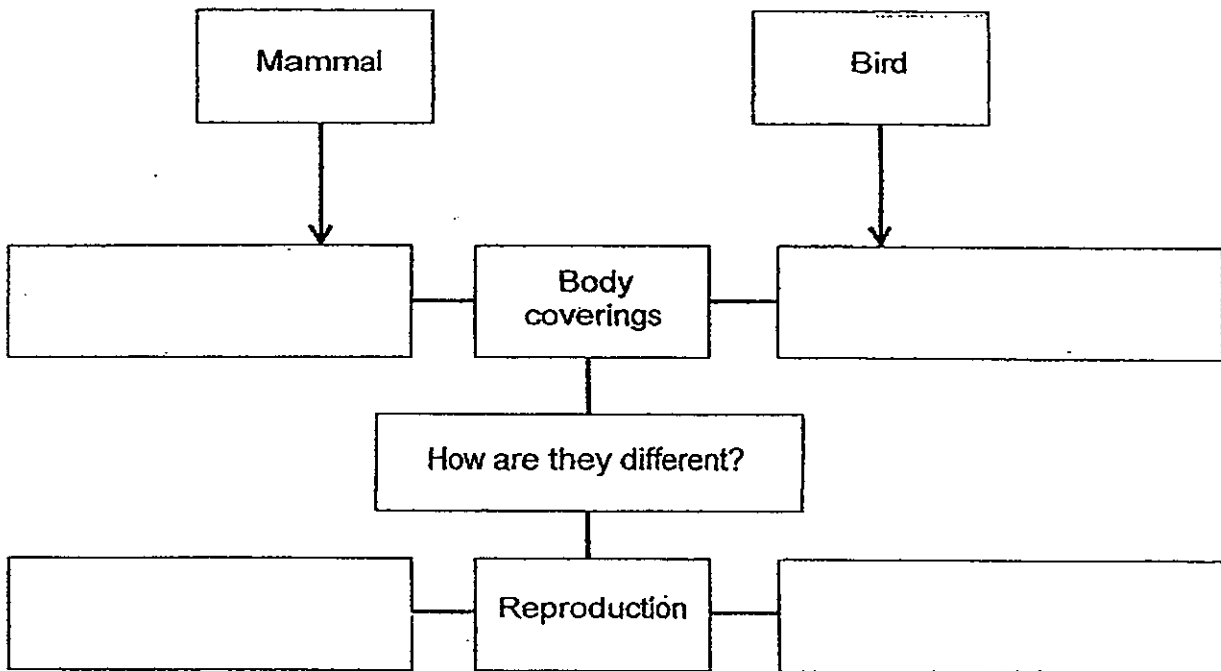

- (b) A bat can fly like a bird but it is not a bird. Which group of animal does the bat belong to? Give a reason for your answer. [1]

---



---

- 37 Matthew put a plant near his window and observed it. He measured and recorded the plant's height over six weeks.

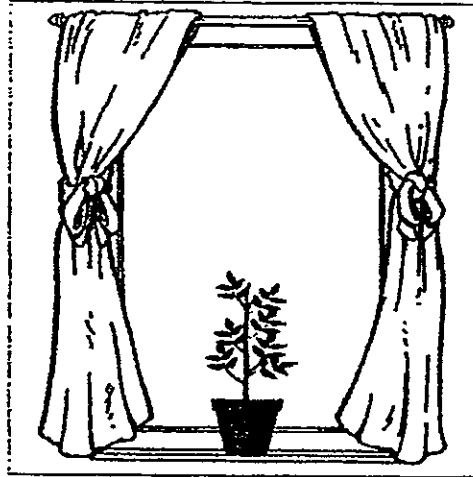

| Week | Height (cm) |
|------|-------------|
| 1    | 12          |
| 2    | 18          |
| 3    | 24          |
| 4    | 34          |
| 5    | ?           |
| 6    | 54          |

- (a) Which characteristic of living things does the plant show? [1]
- \_\_\_\_\_
- \_\_\_\_\_
- (b) What does the plant need to survive? [1]
- \_\_\_\_\_
- (c) Using the results of Matthew's experiment, what would be the height of the plant in Week 5? [1]
- The height of the plant in Week 5 would be \_\_\_\_\_ cm.

|  |
|--|
|  |
|--|

38 The table below shows the characteristics of four animals W, X, Y and Z.

| Animal | Number of legs |   |   |   | Wings | Feelers |
|--------|----------------|---|---|---|-------|---------|
|        | 0              | 2 | 4 | 6 |       |         |
| W      |                |   | ✓ |   |       |         |
| X      |                |   |   | ✓ |       | ✓       |
| Y      |                | ✓ |   |   | ✓     |         |
| Z      | ✓              |   |   |   |       |         |

Put a tick (✓) in the correct box for each of the following statements.

[2]

| Statements                          | True | False | Not possible to tell |
|-------------------------------------|------|-------|----------------------|
| Animal W is likely to be a mammal.  |      |       |                      |
| Animal X is likely to be an insect. |      |       |                      |
| Animal Y is likely to be a bird.    |      |       |                      |
| Animal Z is likely to be a fish.    |      |       |                      |

39 Study the classification table below.

| Animals           |                   |                          |
|-------------------|-------------------|--------------------------|
| W                 | X                 | Y                        |
| Shark<br>Seahorse | Squirrel<br>Panda | Dragonfly<br>Grasshopper |

(a) What are the most suitable headings for each group of animals?

[3]

| W | X | Y |
|---|---|---|
|   |   |   |

(b) In which group can a cow be categorised under?

[1]

|  |
|--|
|  |
|--|

# ANSWER SHEET

**EXAM PAPER 2013**

**SCHOOL : ANGLO-CHINESE SCHOOL (JUNIOR)**

**SUBJECT : PRIMARY 3 SCIENCE**

**TERM : SA1**

---

|    |    |    |    |    |    |    |    |    |     |     |     |     |     |     |     |     |
|----|----|----|----|----|----|----|----|----|-----|-----|-----|-----|-----|-----|-----|-----|
| Q1 | Q2 | Q3 | Q4 | Q5 | Q6 | Q7 | Q8 | Q9 | Q10 | Q11 | Q12 | Q13 | Q14 | Q15 | Q16 | Q17 |
| 3  | 3  | 1  | 4  | 2  | 3  | 2  | 1  | 4  | 3   | 2   | 3   | 2   | 2   | 4   | 2   | 2   |

|     |     |     |     |     |     |     |     |
|-----|-----|-----|-----|-----|-----|-----|-----|
| Q18 | Q19 | Q20 | Q21 | Q22 | Q23 | Q24 | Q25 |
| 3   | 2   | 4   | 4   | 3   | 1   | 4   | 4   |

Section B

Q26

- a) Both of them can fly
- b) Thing Q can move by itself, while thing R cannot move by itself.  
Thing Q can reproduce while thing R cannot reproduce

Q27

- a) Group A animals give birth to young alive, while Group B lays eggs
- b) The male peacock can attract the female peacock so that it can reproduce
- c) The clownfish has an outer covering of scales while the peacock has a outer covering of feathers

Q28

- a) R: Utensils  
S: Stationery
- b) Group R

Q29

- a) Meat eater



b) Living things need food

Q30

a) The fruits in Group H are oval shaped

b) Group G

c) The fruits have the same shape

Q31

a)

| Question                              | Letter |
|---------------------------------------|--------|
| Does it lay eggs?                     | H      |
| Does it give birth to its young plant | G      |

b) Animal Y does not have gills, lays eggs and does not fly

Q32

a) J: Birds

K: Insects

b) i) feathers

ii) To keep them warm

c) Can fly and cannot fly

Q33

a) Plants grow singly and in clusters

Jagged edged and smooth edged plants

b) Mrs Ong's favourite plant is T

Q34

a) Flowering : Rose, Ixora, Orchid, Morning glory

Non-flowering: Fern

b) Flowering plants

Q35

a)

| Outer coverings |            |         |         |
|-----------------|------------|---------|---------|
| Scales          | Feathers   | Y       | Shell   |
| Guppy           | Kingfisher | Pony    | Lobster |
| Seahorse        | Eagle      | Giraffe |         |
|                 |            | Bear    |         |

b) Hair

Q36)

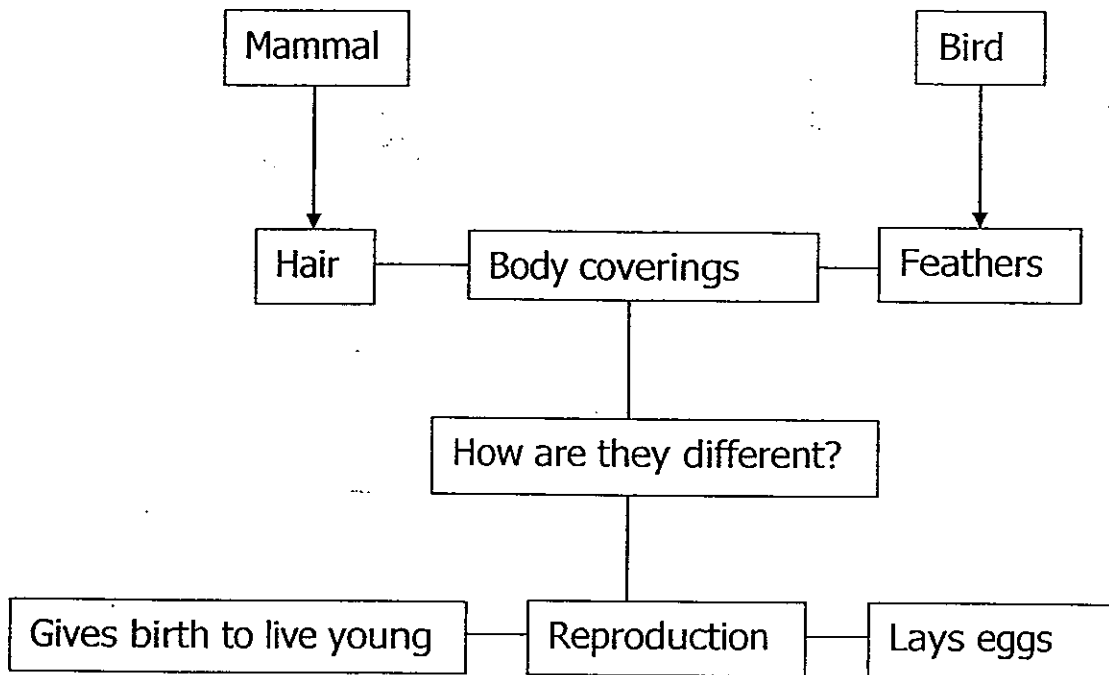

b) Mammal. As a bat gives birth to young alive

Q37

- a) Living things grow
- b) The plant needs air, food, water and sunlight to survive
- c) 44

Q38

| Statements                         | true | false | Not possible to tell |
|------------------------------------|------|-------|----------------------|
| Animal W is likely to be a mammal  | √    |       | √                    |
| Animal X is likely to be an insect | √    |       |                      |
| Animal Y is likely to be a bird    | √    |       | √                    |
| Animal Z is likely to be a fish    | √    |       | √                    |

Q39

- a) W: fishes  
X: Mammals  
Y: Insects
- b) Group X





**CATHOLIC HIGH SCHOOL  
SEMESTRAL ASSESSMENT 1  
2013  
PRIMARY THREE**

**SCIENCE**

**BOOKLET A**

Name: \_\_\_\_\_ ( )

Class: Primary 3 - \_\_\_\_\_

Date: 22 May 2013

30 questions

60 marks

Total Time for Booklets A & B: 1 hour 30 minutes

**Instructions to Candidates**

Do not turn over this page until you are told to do so.

Follow all instructions carefully.

Answer all questions.

Shade your answers in the Optical Answer Sheet (OAS) provided.

This booklet consists of 15 printed pages, excluding cover page.

**Booklet A (30 × 2 marks)**

For each question from 1 to 30, four options are given. One of them is the correct answer. Make your choice (1, 2, 3 or 4). Shade your answer on the Optical Answer Sheet. (60 marks)

---

1. Which one of the following groups consists of only non-living things?

- (1) Fan, plant, rain
- (2) Air, candle, girl
- (3) Ant, grass, water
- (4) Rain, cloud, smoke

2. Study the objects below carefully.

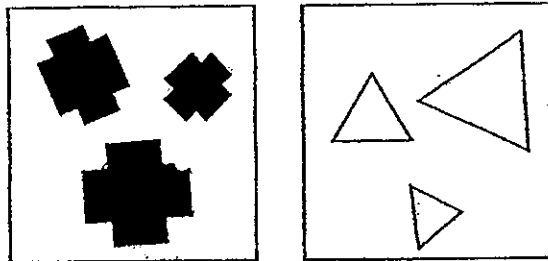

The objects above are grouped according to their \_\_\_\_\_.

- A : sizes
- B : shapes
- C : colours

- (1) A and B only
- (2) A and C only
- (3) B and C only
- (4) A, B and C

3. Look at the classification chart below.

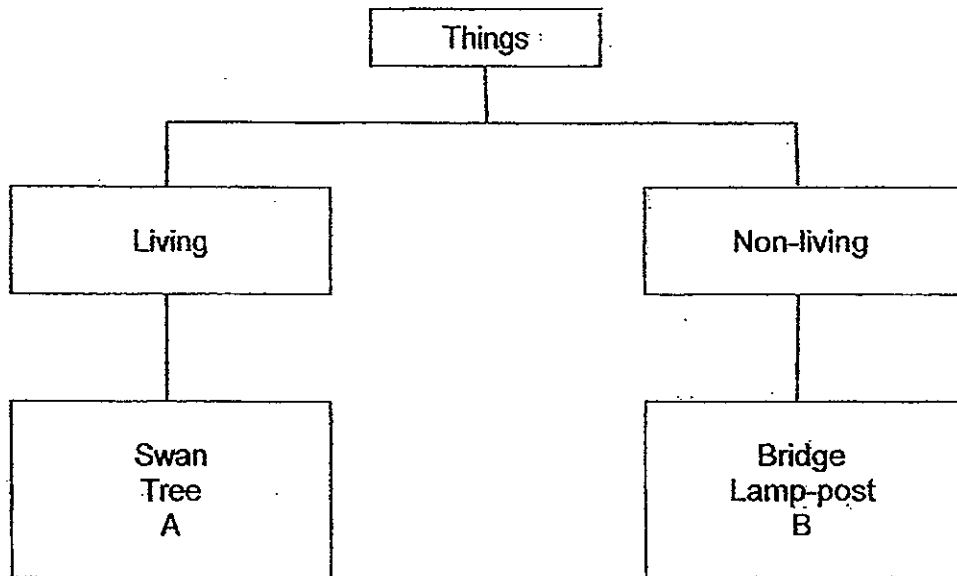

What do A and B best represent?

|     | A          | B     |
|-----|------------|-------|
| (1) | Stone      | Ant   |
| (2) | Squirrel   | Grass |
| (3) | Butterfly  | Chair |
| (4) | Dried leaf | Bench |

4. The table below shows some information about an organism.

| Week | Height cm |
|------|-----------|
| 1    | 10        |
| 2    | 20        |
| 3    | 30        |

Based on the table above, what can you say about the organism?

- (1) The organism is dead after 3 weeks.
- (2) The organism is growing as the weeks go by.
- (3) The organism is reproducing as the weeks go by.
- (4) The organism is moving over a distance as the weeks go by.

5. Study the four statements made by four children below.

- Aaron All living things need air.  
Benny All living things need food.  
Caleb All living things need water.  
Dann All living things need sunlight.

Who have made a correct statement?

- (1) Aaron and Benny only
  - (2) Caleb and Dann only
  - (3) Aaron, Benny and Caleb only
  - (4) Aaron, Benny and Dann only
6. A month ago, Nelson had only 7 guppies in his fish tank. Now, he has 15 guppies in his fish tank although he did not buy any new fish. Which one of the following statements best explains the increase of guppies in Nelson's fish tank?
- (1) Guppies reproduce to respond to changes in their surroundings.
  - (2) Guppies can move on their own to escape from danger and to look for food.
  - (3) Guppies reproduce by laying eggs to ensure that their kind will not become extinct.
  - (4) Guppies give birth to their young alive to ensure that their kind will not become extinct.
7. Read the 3 statements below carefully.
- The bird flew away when a gunshot was fired.
  - Henry laughed loudly when his friend tickled him.
  - The mimosa plant folded its leaves when someone touched it.

The above examples show that living things \_\_\_\_\_.

- (1) can grow
- (2) can move
- (3) need air, food and water
- (4) can respond to changes

8. Study the table below carefully.

Which one of the following is most likely a non-living thing?

|     | Can move from place to place | Needs air, food and water | Can reproduce |
|-----|------------------------------|---------------------------|---------------|
| (1) | ✓                            |                           |               |
| (2) | ✓                            | ✓                         | ✓             |
| (3) | ✓                            | ✓                         | ✓             |
| (4) |                              | ✓                         | ✓             |

9. Some animals are put into groups as shown below.

| J    | K       | L        | M           |
|------|---------|----------|-------------|
| lion | hen     | goldfish | fly         |
| dog  | parrot  | guppy    | grasshopper |
| bat  | sparrow | shark    | butterfly   |

Look at the animal shown below.

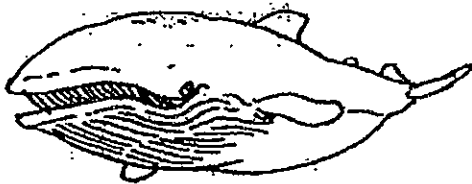

In which group would you put this animal?

- (1) J
- (2) K
- (3) L
- (4) M



10. Study the classification chart below.

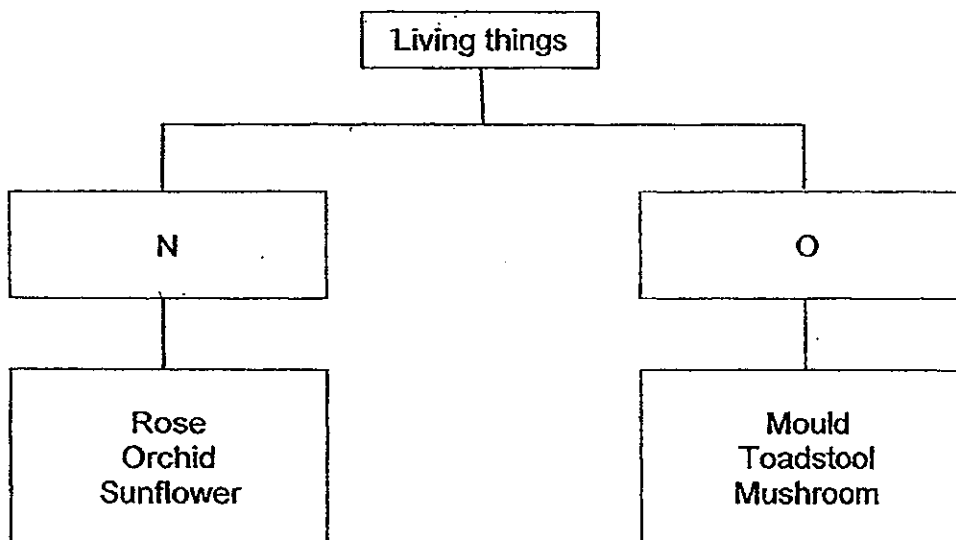

Which of the following gives the most suitable headings for both Groups N and O?

|     | N                    | O              |
|-----|----------------------|----------------|
| (1) | Flowering plants     | Fungi          |
| (2) | Flowering plants     | Micro-organism |
| (3) | Non-flowering plants | Yeast          |
| (4) | Non-flowering plants | Micro-organism |

11. Look at the classification chart below.

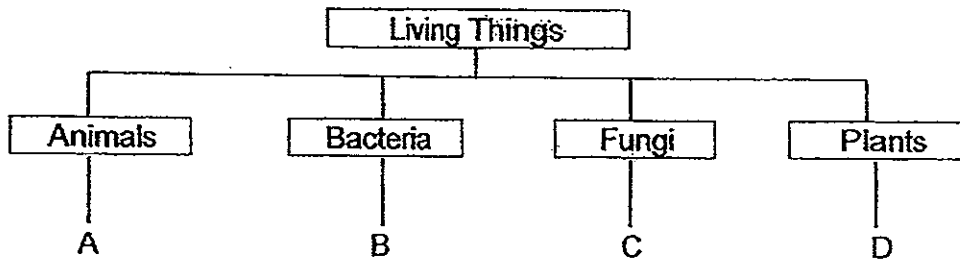

What do A, B, C and D best represent?

|     | A      | B         | C         | D         |
|-----|--------|-----------|-----------|-----------|
| (1) | monkey | earthworm | yeast     | rose      |
| (2) | horse  | germs     | fern      | orchid    |
| (3) | moss   | mould     | mushroom  | hibiscus  |
| (4) | duck   | germs     | toadstool | sunflower |

12. Which of the following living things are grouped correctly?

|     | Birds  | Mammals | Fish     | Plants   |
|-----|--------|---------|----------|----------|
| (1) | eagle  | deer    | shark    | papaya   |
| (2) | bat    | whale   | goldfish | orchid   |
| (3) | pigeon | cat     | dolphin  | mushroom |
| (4) | toucan | dog     | guppy    | mould    |

13. Study the flowchart below carefully.

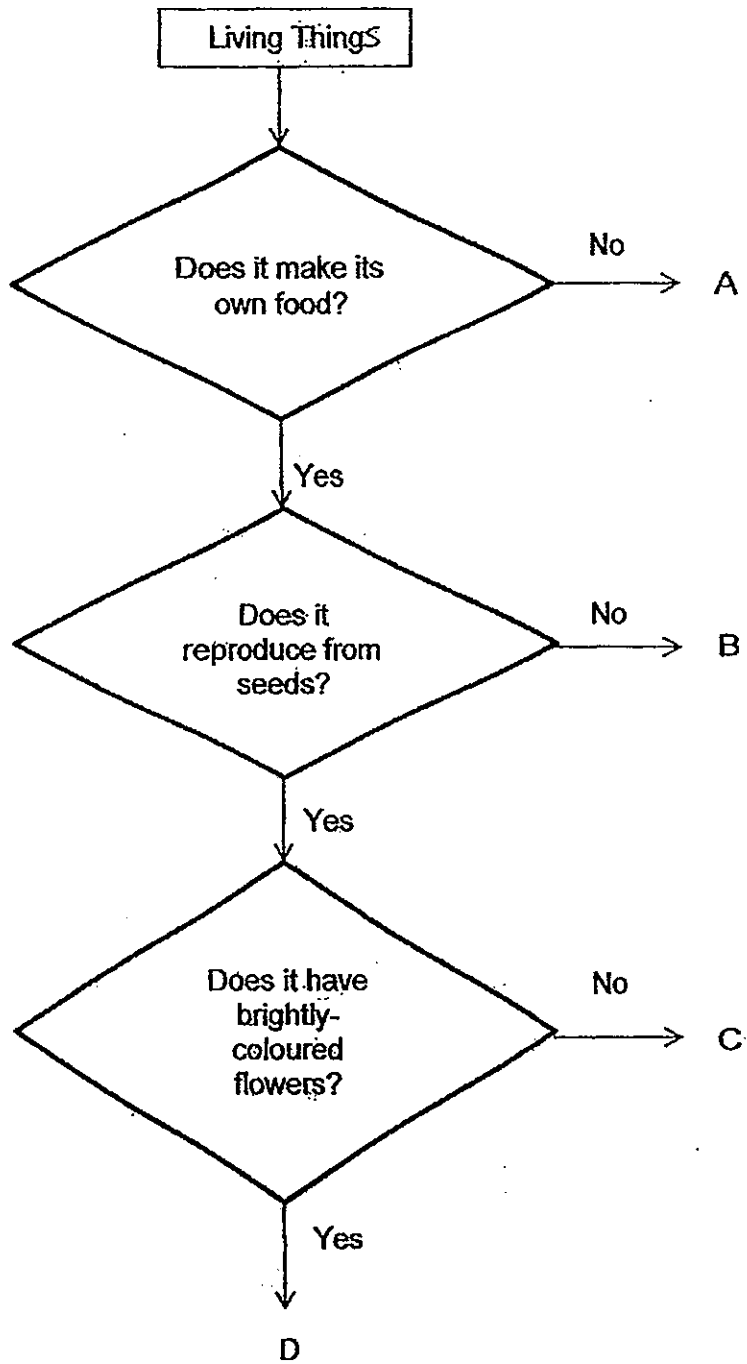

Which one of the following best represents the fern?

- (1) A
- (2) B
- (3) C
- (4) D

14. Which one of the following statements is true about all plants?

- (1) They are green,
- (2) They have flowers.
- (3) They can make food.
- (4) They reproduce from seeds.

15. The picture below shows a bird's nest fern.

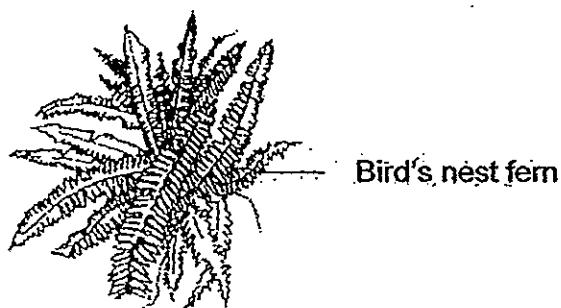

Which of the following statements below are true of the bird's nest fern?

- A : Bears flowers
- B : Makes its own food
- C : Reproduce from spores

- (1) A and B only
- (2) A and C only
- (3) B and C only
- (4) A, B and C

16. Which of the following is a difference between flowering plants and fungi?

|     | Flowering plants                       | Fungi                               |
|-----|--|-------------------------------------|
| (1) | Poisonous                              | Not poisonous                       |
| (2) | Bear flowers                           | Do not bear flowers                 |
| (3) | Can be seen with the naked eye         | Cannot be seen with the naked eye   |
| (4) | Cannot move freely from place to place | Can move freely from place to place |

17. The following four animals are grouped together.

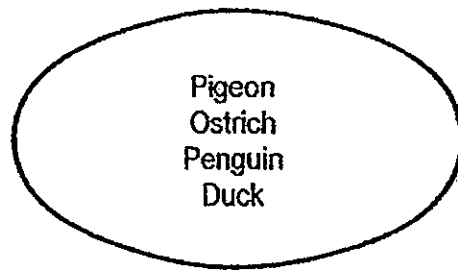

Which of the following characteristics show why they are grouped together?

- S : They can fly.
- T : They waddle and swim.
- U : They have wings and a beak.
- V : Their bodies are covered with feathers..

- (1) S only
- (2) U only
- (3) U and V only
- (4) S, T; U and V

18. Study the classification table below carefully.

| Group M     | Group N  | Group O  | Group P |
|-------------|----------|----------|---------|
| Ant         | Rabbit   | Dolphin  | Bat     |
| Caterpillar | Kangaroo | Goldfish | Eagle   |

How are the animals above grouped?

- (1) By their sizes.
- (2) By the way they move.
- (3) By the way they reproduce..
- (4) By their outer body coverings.

19. In which of the following are the animals grouped correctly?

|     | Hair    | Feathers | Scales |
|-----|---------|----------|--------|
| (1) | Penguin | Ostrich  | Guppy  |
| (2) | Dog     | Bat      | Guppy  |
| (3) | Penguin | Bat      | Molly  |
| (4) | Dog     | Ostrich  | Molly  |

20. Study the flow chart below carefully.

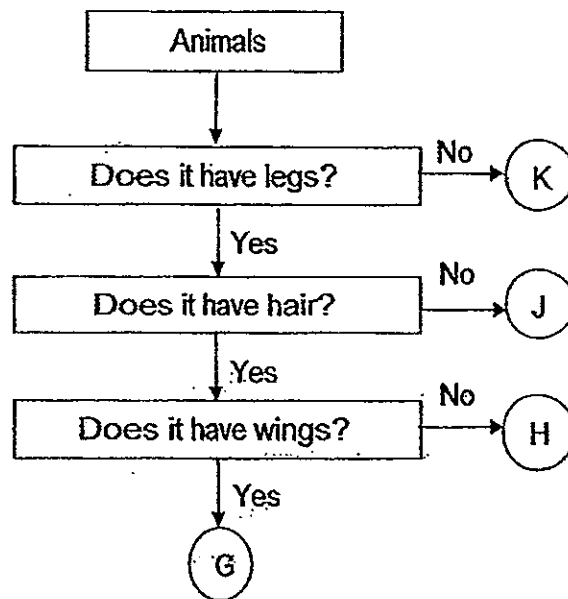

Which one of the following animals is best represented by H?

- (1) Bat
- (2) Whale
- (3) Penguin
- (4) Giraffe

21. Which one of the following is true about bacteria?

- (1) Bacteria reproduce by spores.
- (2) All bacteria are harmful to man.
- (3) Bacteria exist in different shapes.
- (4) Bacteria can only be found in very cold places.

22. Which of the following statements are true about bread mould?

- P : It reproduces by spores.
- Q : It needs water to grow.
- R : It can make its own food.

- (1) P and Q only
- (2) Q and R only
- (3) P and R only
- (4) P, Q and R

23. Look at the two organisms below.



Mushroom



Mould

How are the mushroom and mould similar?

- (1) They can move on their own.
- (2) They can make their own food.
- (3) They belong to the same group called fungi.
- (4) They do not need air, food and water to survive.

24. Some living things are classified into two groups as shown in the chart below.

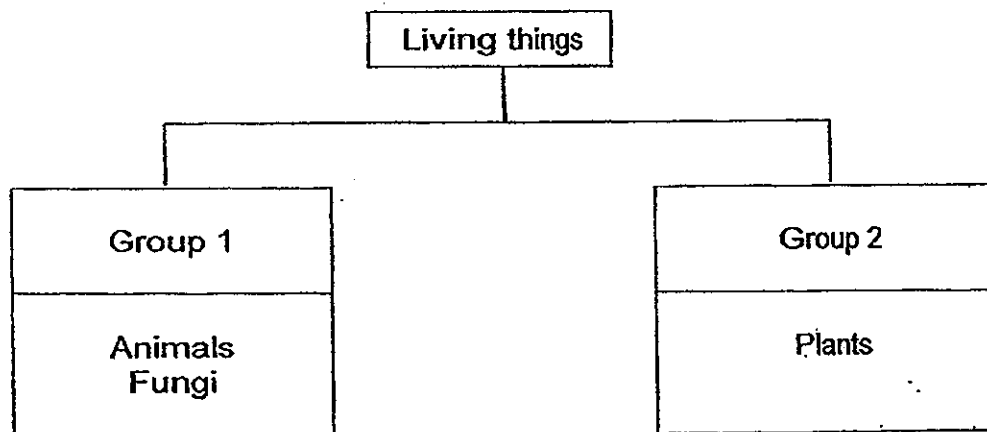

The living things are grouped according to whether they \_\_\_\_\_.

- (1) reproduce from spores or reproduce from seeds
- (2) need oxygen or do not need oxygen to stay alive
- (3) can make their own food or cannot make their own food
- (4) produce carbon dioxide or do not produce carbon dioxide

25. Object Z is used to open the lid of the tin shown below.

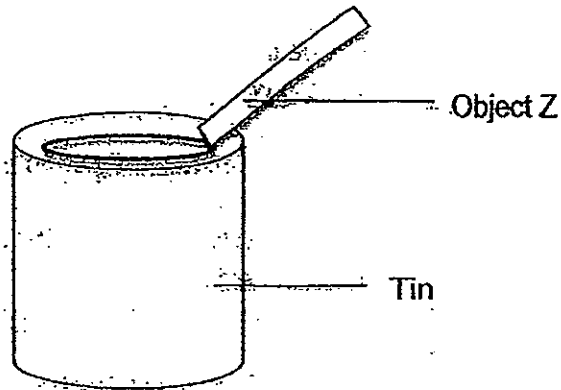

Which one of the following materials is most suitable to make Object Z?

- (1) Metal
- (2) Glass
- (3) Fabric
- (4) Rubber

26. Materials used to make raincoats, umbrellas and plastic bags should be \_\_\_\_\_.

- W : soft
- X : flexible
- Y : waterproof
- Z : transparent

- (1) Y only
- (2) X and Y only
- (3) W and X only
- (4) W, X, Y and Z



27. The table below shows the properties of some materials.

| Material | Properties   |
|----------|--|
| E        | <ul style="list-style-type: none"> <li>flexible</li> <li>allows light to pass through</li> </ul>             |
| F        | <ul style="list-style-type: none"> <li>flexible</li> <li>does not allow light to pass through</li> </ul>     |
| G        | <ul style="list-style-type: none"> <li>not flexible</li> <li>allows light to pass through</li> </ul>         |
| H        | <ul style="list-style-type: none"> <li>not flexible</li> <li>does not allow light to pass through</li> </ul> |

Which material is most suitable for making a fish tank?

- (1) E
- (2) F
- (3) G
- (4) H

28. The diagram below shows how some objects are classified according to the materials they are made of.

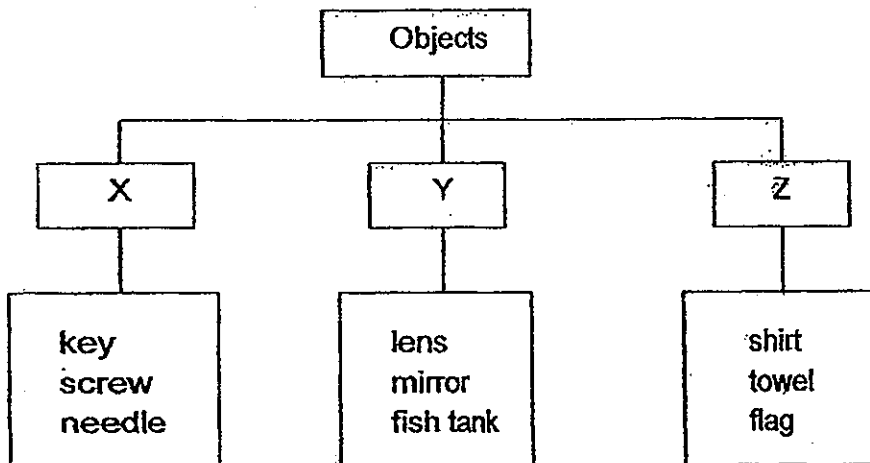

What materials do X, Y and Z represent?

|     | X       | Y       | Z      |
|-----|---------|---------|--------|
| (1) | Metal   | Glass   | Fabric |
| (2) | Metal   | Wood    | Fabric |
| (3) | Plastic | Glass   | Rubber |
| (4) | Rubber  | Plastic | Paper  |

29. Simon tested the strength of five different materials by dropping a 1-kg weight from a height of 1 metre. All five materials have the same shape and size. He noted the number of times the weight was dropped before the material broke into two pieces.

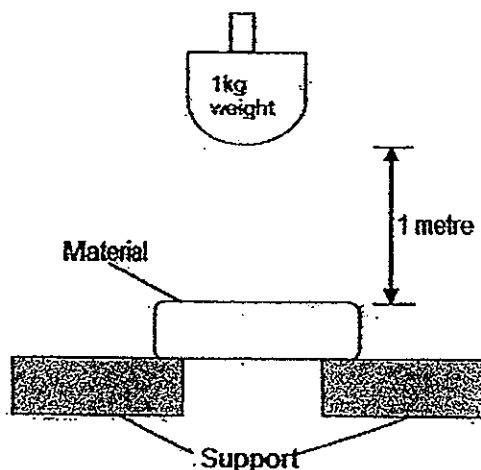

The results were shown in the table below.

| Material | Number of 'drops' |
|----------|-------------------|
| P        | 48                |
| Q        | 37                |
| R        | 64                |
| S        | 23                |
| T        | 51                |

Based on the results above, which one of the following statements best describes the materials correctly?

- (1) Material T is a metal.
- (2) Material P is stronger than Material R.
- (3) Material T is hard enough to scratch Material Q.
- (4) Material S will be the first to break if a 2kg weight is dropped on it.

30. Four types of materials underwent a scratch test. The results are shown in the diagram below.

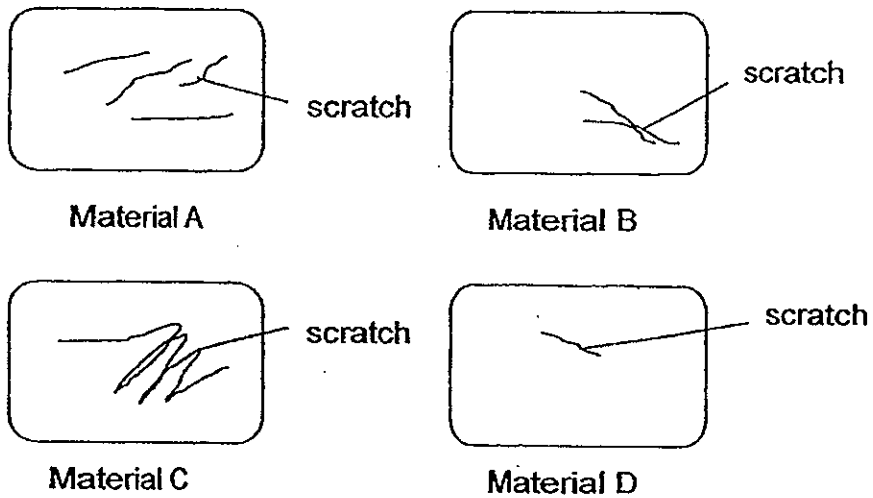

What can you conclude from the test results?

- (1) Material C is the hardest material.
- (2) Material D is the hardest material.
- (3) Material C is stronger than Material A.
- (4) Material D is stronger than Material B.

**End of Booklet A**



**CATHOLIC HIGH SCHOOL  
SEMESTRAL ASSESSMENT 1  
2013  
PRIMARY THREE**

**SCIENCE**

**BOOKLET B**

Name: \_\_\_\_\_ ( )

Class: Primary 3 - \_\_\_\_\_

Date: 22 May 2013

|           |     |
|-----------|-----|
| Booklet A | 60  |
| Booklet B | 40  |
| Total     | 100 |

14 questions

40 marks

Total Time for Booklets A & B: 1 hour 30 minutes

**Instructions to Candidates**

Do not turn over this page until you are told to do so.

Follow all instructions carefully.

Answer all questions.

Write your answers in this booklet.

This booklet consists of 13 printed pages, excluding cover page.

**Booklet B (40 marks)**

For questions 31 to 44, write your answers in this booklet.

The number of marks available is shown in brackets [ ] at the end of each question or part question. (40 marks)

31. Classify the following objects in the chart below. [2]

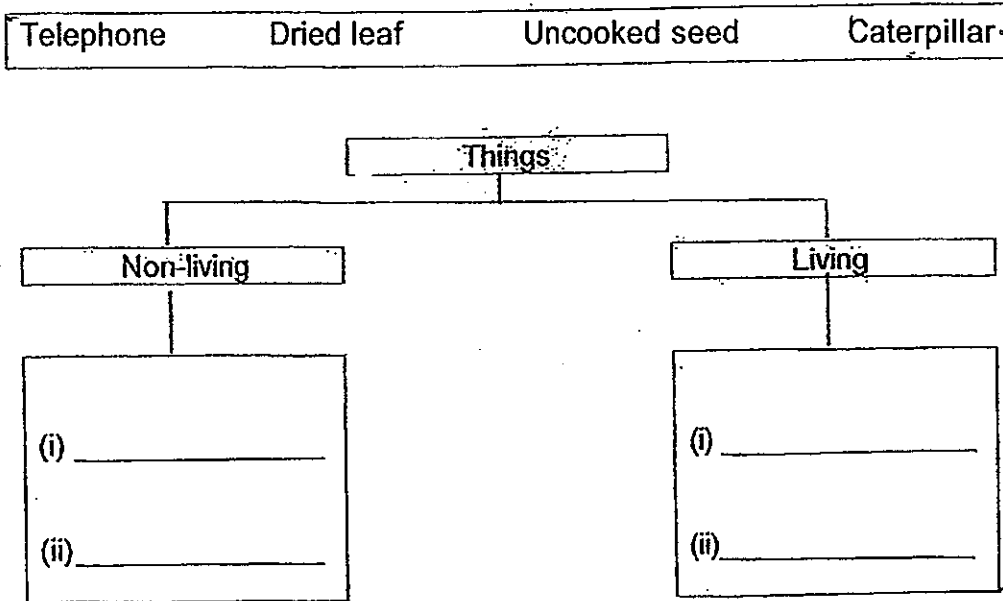

32. For each of the following statements, write "T" for true and "F" for false in the boxes provided. [2]

|   |  |
|---|--|
| (a) All insects have wings.   |  |
| (b) All birds have feathers on their bodies.                            |  |
| (c) All birds have wings and can fly.                                   |  |
| (d) Some mammals lay eggs instead of giving birth to their young alive. |  |

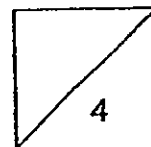

33. Asher bought a pet bird from a pet shop.

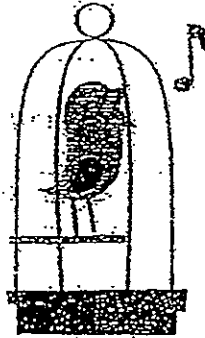

(a) What are the two things that Asher should put into the bird cage so that the bird can stay alive? [1]

---

---

(b) When Asher tried to catch the bird with his hands, the bird tried to fly away. Which two characteristics of living things did the bird show? [2]

(i) \_\_\_\_\_

(ii) \_\_\_\_\_

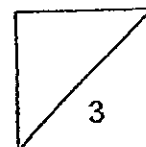

34. The graph below shows the changes in height of a living thing over a period of time.

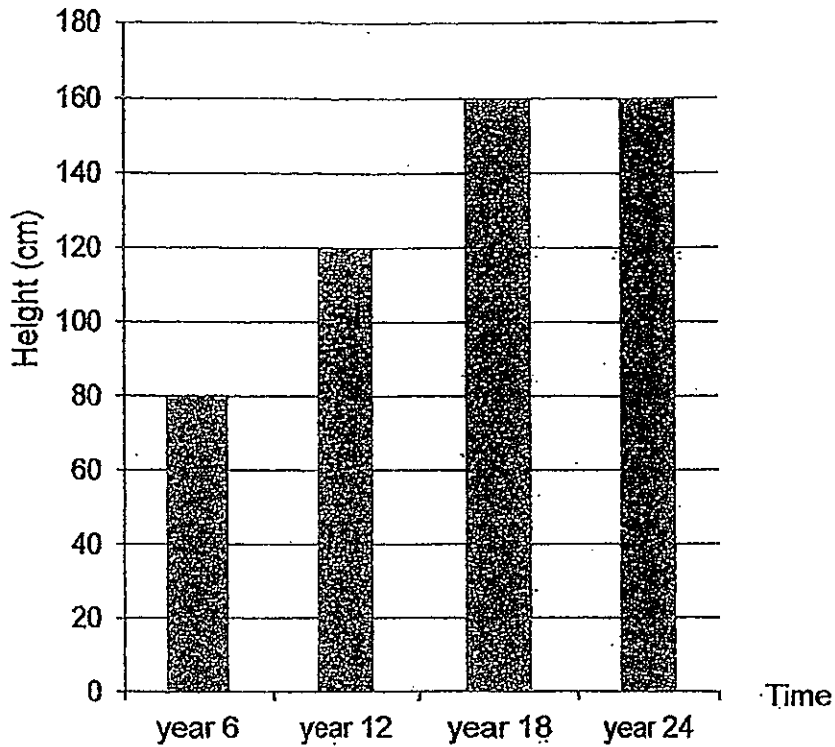

- (a) (i) What is the height of the living thing at year 6? [1]

---

- (ii) How old was the living thing when it was 120cm tall? [1]

---

- (b) What does this graph tell us about living things? [1]

---

---

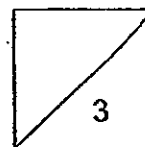

35. (a) Jason wants to find out if an animal is an insect. What are the possible actions he should take to confirm if it is an insect? Put a tick accordingly. [1]

| Actions                                 | Tick (✓) |
|---|----------|
| Measure its length                      |          |
| Check to see if it has wings            |          |
| Check to see if it has feelers          |          |
| Check to see if it has six legs         |          |
| Check to see if it has three body parts |          |

- (b) Jason found Animal X shown below.



Animal X

He concluded that Animal X is not an insect.  
Do you agree with him? Give a reason to support your answer. [1]

---



---

- (c) How do insects reproduce? [1]

---



---

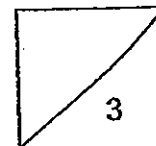



36. Study the two types of plants below carefully.



Hibiscus



Arrowhead

Based on the diagrams above, state one similarity and one difference between the two plants. (Do not compare shape and size.)

[2]

Similarity:

---

---

Difference:

---

---

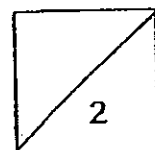

37. The table below shows the characteristics of four plants, A, B, C and D.

| Characteristics    | Plants |   |   |   |
|--------------------|--------|---|---|---|
|                    | A      | B | C | D |
| Has flowers        | ✓      |   |   | ✓ |
| Grows in the water |        | ✓ |   | ✓ |

(a) Based on the table above, classify the plants (A, B, C and D) in the classification chart below. [2]

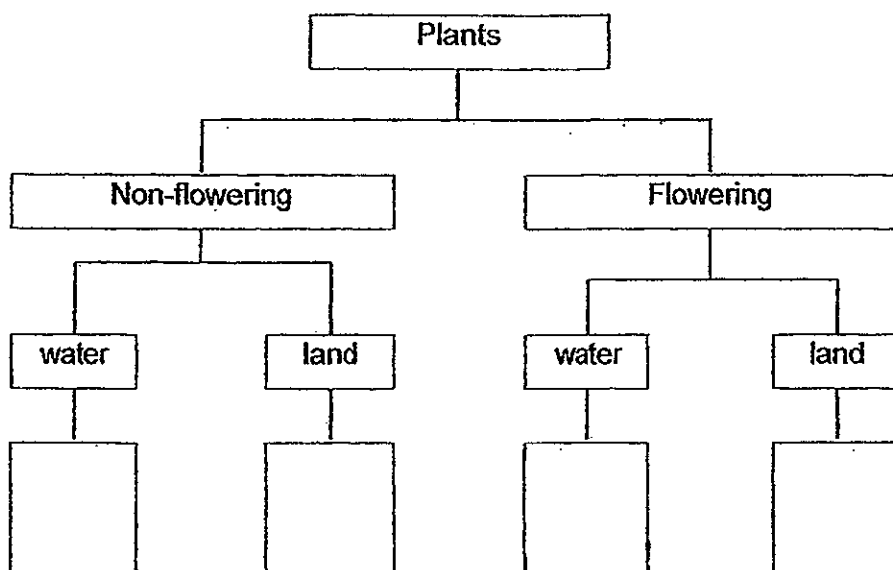

(b) Based on the information given, list two characteristics of Plant B. [2]

(i) \_\_\_\_\_

(ii) \_\_\_\_\_

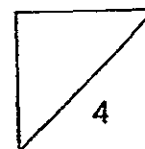

38. Four animals are shown in the diagram below.

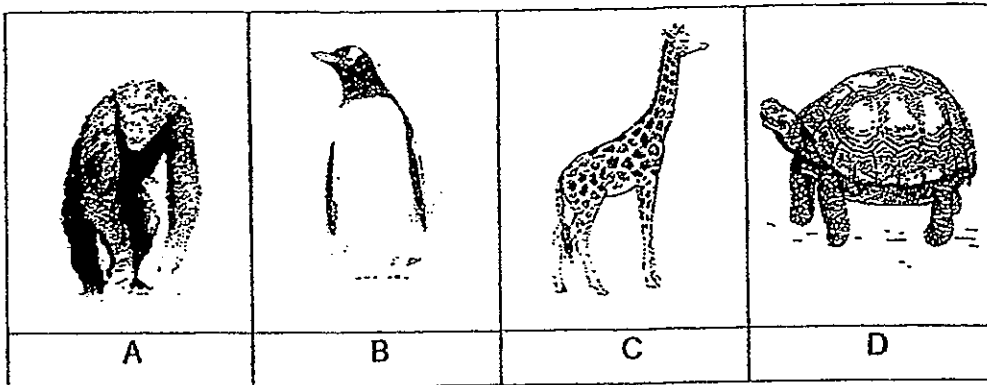

(a) Which two animals, A, B, C or D, can be put into the same group of animals? [1]

\_\_\_\_\_

(b) State two common characteristics between the two animals you have chosen in (a). [2]

(i) \_\_\_\_\_

(ii) \_\_\_\_\_

39. The pictures below show two animals.



Animal X



Animal Y

(a) How are Animal X and Animal Y ~~different~~ in their body covering? [1]

---

---

(b) List 2 functions of the body covering of Animal X. [2]

(i) \_\_\_\_\_

(ii) \_\_\_\_\_

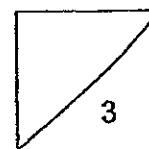

40. (a) Joseph conducted an experiment. He had two similar pieces of bread, A and B. He toasted Bread A and added water to Bread B. Finally, he put both pieces of bread inside a box.

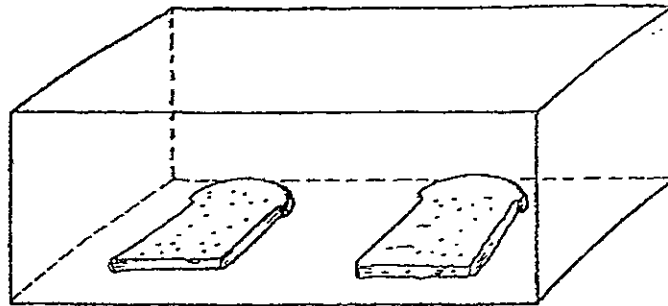

Bread A

Bread B

- (i) What is the aim of Joseph's experiment? [1]

---

---

- (ii) What would he notice about the two pieces of bread after a few days? [1]

---

---

- (b) Why are bacteria also called micro-organisms? [1]

---

---

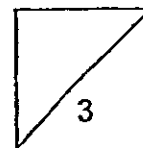

41. Zavier conducted an experiment to find out the amount of fungi growing on different brands of bread after 6 days. The results of the experiment are shown in the table below.

| Brand of Bread | Fungal Growth on Bread |
|----------------|------------------------|
| A              | +++                    |
| B              | +                      |
| C              | ++                     |
| D              | ++++                   |

Key  
+ amount of fungi

- (a) Based on the results above, which brand of bread will you buy if you want the bread to last the longest? [1]

---

- (b) Explain your answer in (a). [1]

---

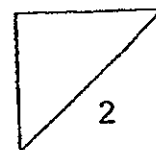

42. Annie's class is involved in a recycling project. The following are the objects Annie found in the recycling bin.

|                      |        |              |          |
|----------------------|--------|--------------|----------|
| Drinking straw       | Mirror | Canned drink | Magazine |
| Mineral water bottle |        | Milk carton  |          |

Based on the materials the objects are made of, classify the objects under the correct materials.

[3]

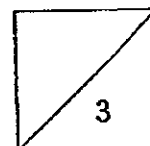
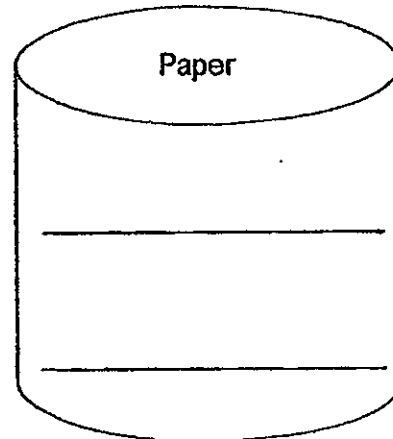
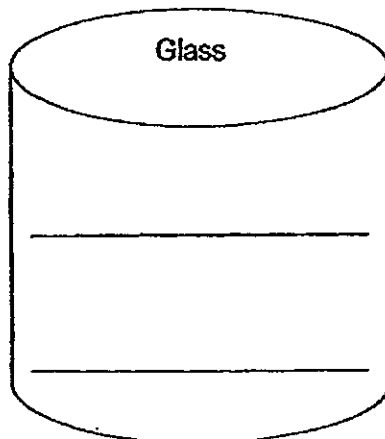
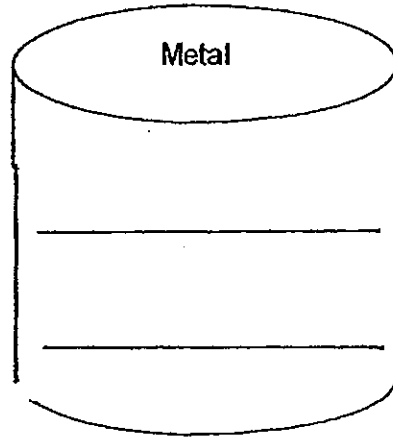
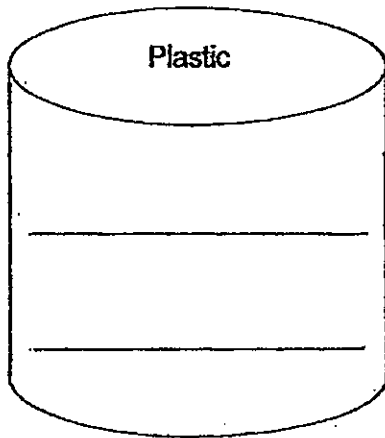

43. Benjamin wanted to buy a file to keep his test papers properly. He saw 2 types of files in the bookshop as shown in the pictures below.

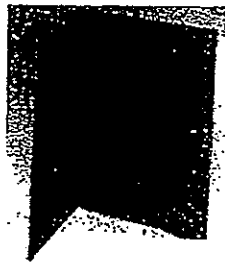

paper file



plastic file

- (a) Which file should he buy if he did not want his test papers to get wet? [1]

---

- (b) Give two reasons for your choice in (a). [2]

(i) \_\_\_\_\_

(ii) \_\_\_\_\_

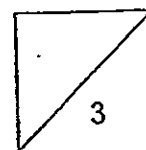



44. (a) Classify the following objects into two groups. [1]

|       |        |            |           |
|-------|--------|------------|-----------|
| scarf | magnet | blanket in | iron nail |
|-------|--------|------------|-----------|

| Group 1 | Group 2 |
|---------|---------|
|         |         |

(b) Give a suitable heading for each group. [1]

Group 1: \_\_\_\_\_

Group 2: \_\_\_\_\_

(c) State a property of the material that is suitable to make the objects in Group 1 and Group 2. [2]

Group 1: \_\_\_\_\_

Group 2: \_\_\_\_\_

**End of Booklet B**

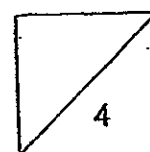

# ANSWER SHEET

**EXAM PAPER 2013**

**SCHOOL : CATHOLIC HIGH SCHOOL**

**SUBJECT : PRIMARY 3 SCIENCE**

**TERM : SA1**

|    |    |    |    |    |    |    |    |    |     |     |     |     |     |     |     |     |
|----|----|----|----|----|----|----|----|----|-----|-----|-----|-----|-----|-----|-----|-----|
| Q1 | Q2 | Q3 | Q4 | Q5 | Q6 | Q7 | Q8 | Q9 | Q10 | Q11 | Q12 | Q13 | Q14 | Q15 | Q16 | Q17 |
| 4  | 3  | 3  | 2  | 3  | 4  | 4  | 1  | 1  | 1   | 4   | 1   | 2   | 3   | 3   | 2   | 3   |

|     |     |     |     |     |     |     |     |     |     |     |     |     |
|-----|-----|-----|-----|-----|-----|-----|-----|-----|-----|-----|-----|-----|
| Q18 | Q19 | Q20 | Q21 | Q22 | Q23 | Q24 | Q25 | Q26 | Q27 | Q28 | Q29 | Q30 |
| 2   | 4   | 4   | 3   | 1   | 3   | 3   | 1   | 2   | 3   | 1   | 4   | 2   |

Section B

Q31)

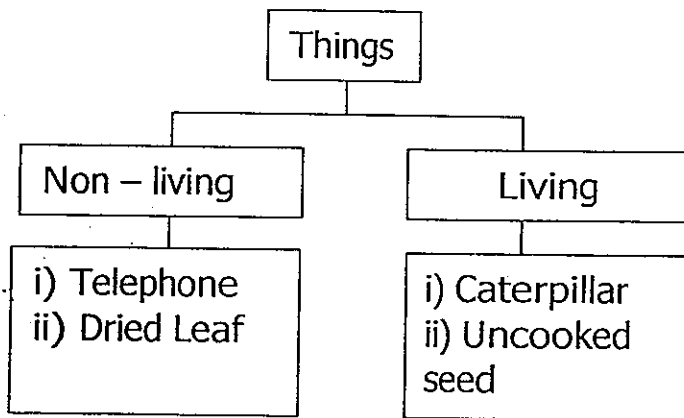

- Q32) a) F  
b) T  
c) F  
d) T

- Q33) a) He should put some water and food  
b) i) Living things respond to changes  
ii) Living things can move by themselves

- Q34) a) i) 80cm  
 ii) 12 years old  
 b) Living things grow

Q35) a)

| Actions                                    | Tick (✓) |
|--|----------|
| Measure its length                         |          |
| Check to see if it has wings               |          |
| Check to see if it is has feelers          | ✓        |
| Check to see if it is has six legs         | ✓        |
| Check to see if it is has three body parts | ✓        |

- b) Yes. It has 8 legs  
 c) Insects lay eggs

Q36) Similarity: They both have leaves

Difference: The arrowhead is an aquatic plant while the hibiscus is a land plant.

Q37) a)

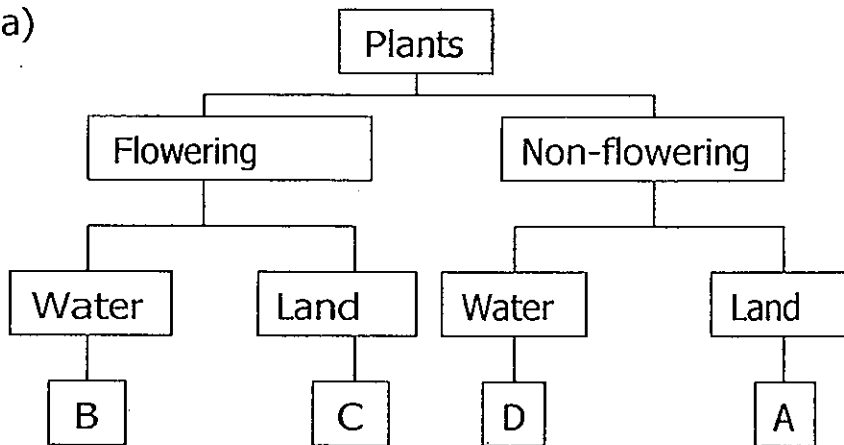

- b) i) Plant B does not have flowers  
 ii) Plant B grows in water

Q38) a) A and C

- b) i) They both have hair  
 ii) They both feed their young with milk

Q39) a) Animal X has feathers while Animal Y has hair

- b) i) The feathers help to keep Animal X warm  
 ii) The feathers help Animal X to fly

Q40) a) i) The aim is to find if mould grows better with or without water  
ii) There will be mould growing on Bread B, and no mould growing on Bread A  
b) They are very small living things that can only be seen using a microscope

Q41) a) Bread B  
b) Bread B has less fungal growth than other brands of bread

Q42) Plastic: Drinking straw, Mineral water bottle  
Metal: Canned Drink  
Glass: Mirror  
Paper: Milk carton, Magazine

Q43) a) Plastic file  
b) i) It is waterproof  
ii) It is strong

Q44) a) Group 1: Scarf, blanket  
Group 2: Magnet, Iron nail  
b) Group 1: Made of Fabric  
Group 2: Made of Metal  
c) Group 1: Soft  
Group 2: Hard



Name: \_\_\_\_\_ ( )

Class : Primary 3 \_\_\_\_\_

## CHIJ ST NICHOLAS GIRLS' SCHOOL



Primary 3

Semestral Assessment One

SCIENCE

BOOKLET A

15 May 2013

Total Time for Booklets A and B: 1 h 45 min

30 Questions

60 Marks

Do not open this booklet until you are told to do so.

Follow all instructions carefully.

Answer all questions.

This booklet consists of 17 printed pages.

**Section A : ( 30 x 2 MARKS )**

For each question from 1 to 30, 4 options are given. One of them is the correct answer. Make your choice (1, 2, 3 or 4). Shade your answer on the Optical Answer Sheet.

1. Which one of the following groups is classified correctly?

|     | Living Things | Non-living Things |
|-----|---------------|-------------------|
| (1) | cow           | balsam seed       |
| (2) | wooden table  | chair             |
| (3) | coconut tree  | flowerpot         |
| (4) | dried leaf    | vase              |

2. The table below shows the characteristics of plants A, B, C and D.

| Characteristic               | Plants |     |     |     |
|------------------------------|--------|-----|-----|-----|
|                              | A      | B   | C   | D   |
| Does the plant live on land? | Yes    | Yes | No  | Yes |
| Are the fruits poisonous?    | No     | No  | No  | Yes |
| Do the flowers grow singly?  | No     | Yes | Yes | No  |

Based on the information given in the table above, which one of the following statements about plants A, B, C and D is true?

- (1) Plant A bears poisonous fruits and the flowers grow singly.
- (2) Plant B bears poisonous fruits and the flowers grow singly.
- (3) Plant C is not a land plant and it bears non-poisonous fruits.
- (4) Plant D bears non-poisonous fruits and it does not grow on land.

3. The diagram below shows the leaves of a mimosa plant folding up after being touched.



This shows that living things \_\_\_\_\_.

- (1) can grow
  - (2) can reproduce
  - (3) need air, food and water
  - (4) can respond to changes around them
4. Mori removed 2 slices of bread, A and B from a single loaf. She sprinkled some water on A only and toasted B. She put them in Ziplock bags and left the 2 slices of bread in a dark corner of the kitchen.

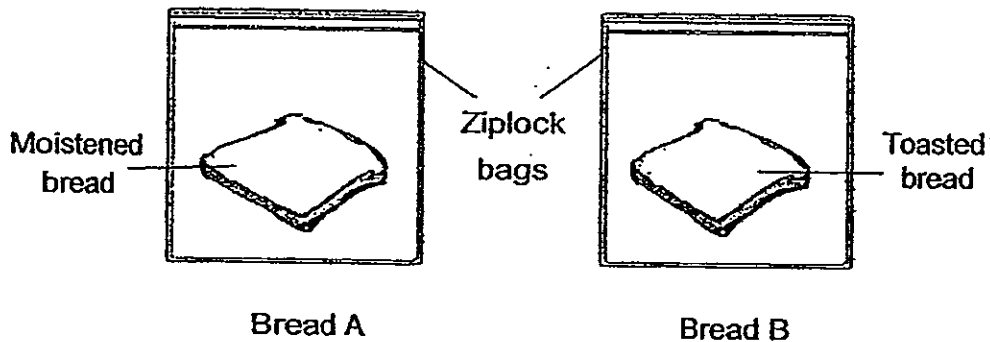

Which one of the following observations would Mori most probably make after 1 week?

- (1) Mould is growing on bread A and B.
- (2) Mould starts to grow on bread A only.
- (3) Mould starts to grow on bread B only.
- (4) No mould is growing on bread A and B.



Gary put 10 houseflies, some slices of banana and some water into an empty jam jar. He then screwed on the lid tightly. Which one of the following graphs best represents the number of live houseflies in the jar over the next four days?

(1)

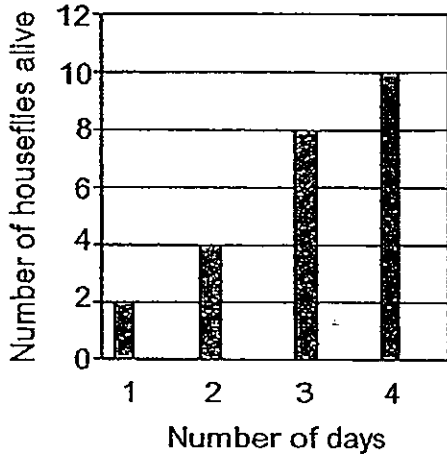

(2)

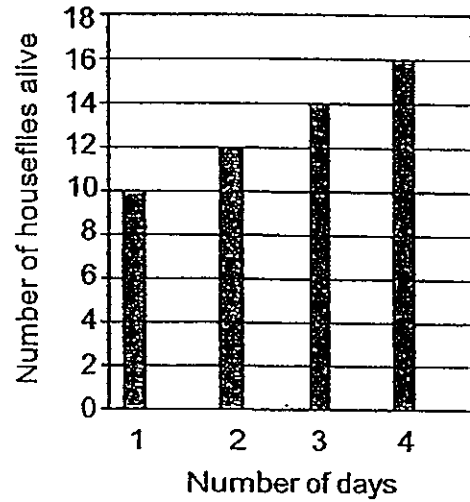

(3)

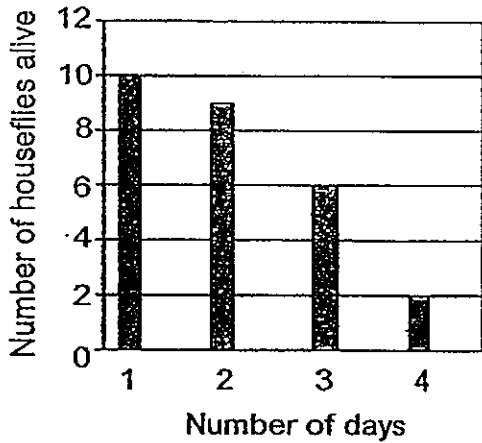

(4)

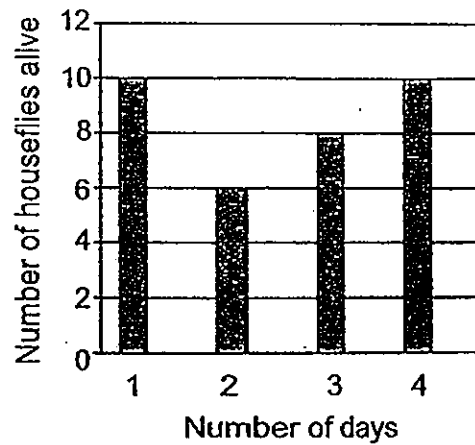

6. 4 similar plants, A, B, C and D, are given different conditions as shown in the diagram below.

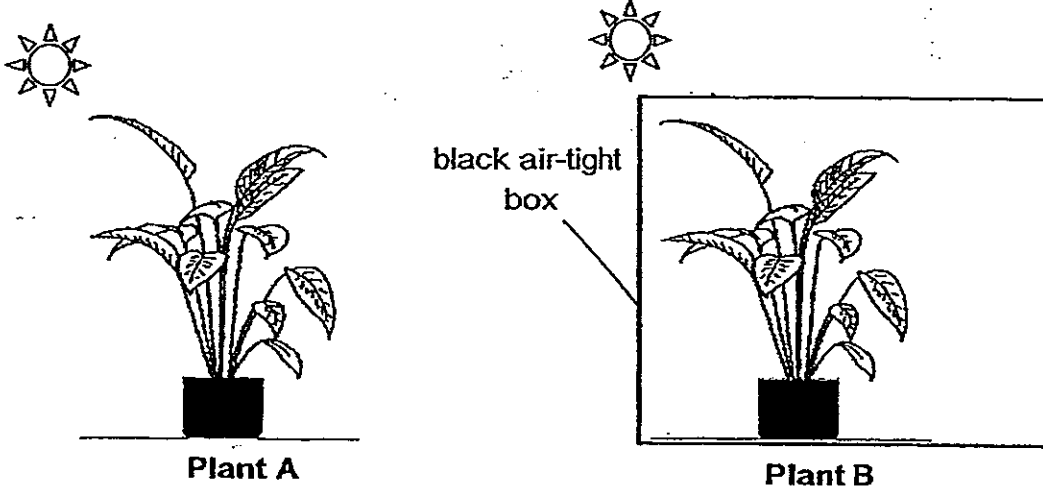

Amount of water given – 50ml  
Location plant is placed - garden

Amount of water given – 50ml  
Location plant is placed - garden

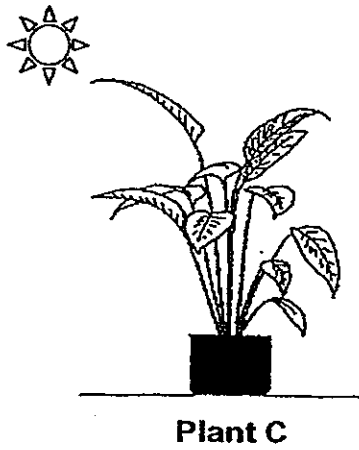

Amount of water given – 0ml  
Location plant is placed - garden



Amount of water given – 50ml  
Location plant is placed – dark room

In which of the above set-ups will the plant survive the best?

- (1) A
- (2) B
- (3) C
- (4) D

7. Which of the following statements are true about the staghorn fern?

- A It is a flowering plant.
- B It reproduces by spores.
- C It is an example of fungi.
- D It can make its own food.

- (1) A and C only
- (2) B and D only
- (3) A, B and D only
- (4) B, C and D only

8. Four pupils, Abi, Ben, Cleo and Dan, made the following statements about living things.

- Abi Living things do not increase in size as they grow.
- Ben Living things will respond to all changes around them.
- Cleo All living things need food, sunlight and water to survive.
- Dan All living things reproduce so that their kind will continue to exist.

Which of the above pupils has/have made the incorrect statements about living things?

- (1) Abi only
- (2) Abi and Cleo only
- (3) Cleo and Dan only
- (4) Abi, Ben and Cleo only

9. Which one of the following statements best describes the similarity between fungi and bacteria?

- (1) They can make their own food.
- (2) They need air, food and water to survive.
- (3) They can be seen only with the help of a microscope.
- (4) They are able to move from place to place by themselves.

10. Alice saw an organism. She wanted to find out whether it is an insect. Which of the following actions would enable her to do so?

- A Measure its length.
- B Find out whether it has wings.
- C Count the number of legs it has.
- D Find out whether it has three body parts.

- (1) A and B only
- (2) C and D only
- (3) B, C and D only
- (4) A, B, C and D

11. Which of the following statements are true of all mammals?

- A They have hair or fur.
- B The adult mammals give birth to live young.
- C The female mammals produce milk to feed their young.

- (1) A and B only
- (2) B and C only
- (3) A and C only
- (4) A, B and C

12. Which one of the following animals has the same kind of outer body covering as the peacock?

- (1) bear
- (2) seal
- (3) eagle
- (4) whale

13. Osman tested four different types of chemicals, L, M, N, P, on some insects including insect Q. The table below shows the effects of the different chemicals on the insects.

| Chemical | Effect on insect Q | Effect on other insects |
|----------|--------------------|-------------------------|
| L        | Attracts           | None                    |
| M        | Attracts           | Kills                   |
| N        | Kills              | Kills                   |
| P        | Kills              | None                    |

Which one of the above chemicals, L, M, N or P, should Osman use to reduce the number of insect Q only?

- (1) L
  - (2) M
  - (3) N
  - (4) P
14. Some animals are classified in a chart as shown below.

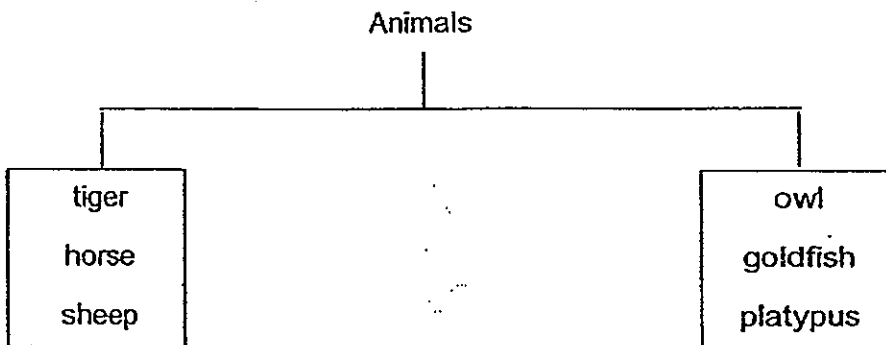

These animals are grouped according to \_\_\_\_\_.

- (1) the way they move
- (2) how they reproduce
- (3) their body coverings
- (4) whether they can respond to changes

15. Which of the following correctly explain the importance of the fins to a fish?

- A Fins help to protect the fish's body.
- B Fins enable a fish to swim in water.
- C Fins help a fish to keep its balance.
- D Fins enable a fish to breathe in water.

- (1) A and D only
- (2) B and C only
- (3) A, B and C only
- (4) A, B, C and D

16. Study the flowchart below.

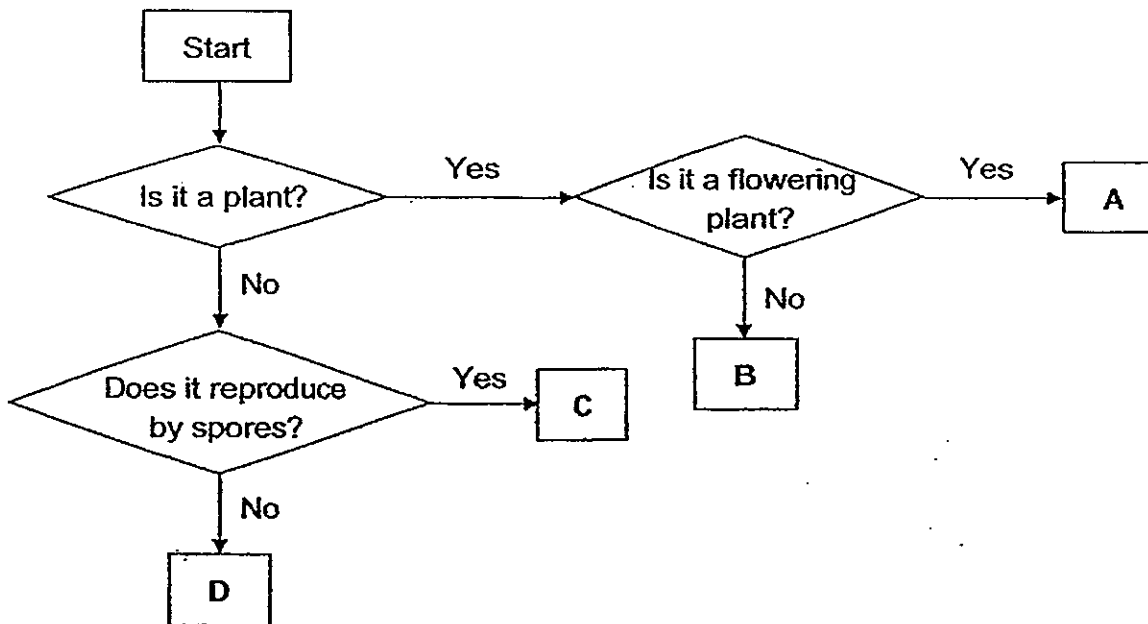

Based on the above flowchart, which one of the following best represents A, B, C and D?

|     | A        | B        | C              | D         |
|-----|----------|----------|----------------|-----------|
| (1) | Orchid   | Moss     | Fem            | Hibiscus  |
| (2) | Rose     | Mushroom | Bacteria       | Toadstool |
| (3) | Conifer  | Fem      | Bracket fungus | Bacteria  |
| (4) | Hibiscus | Conifer  | Toadstool      | Giraffe   |

17. Yati had to classify four animals shown below.

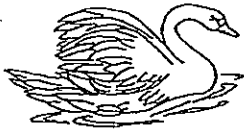

swan



bat



frog



dragonfly

She classified them with the help of the flowchart below.

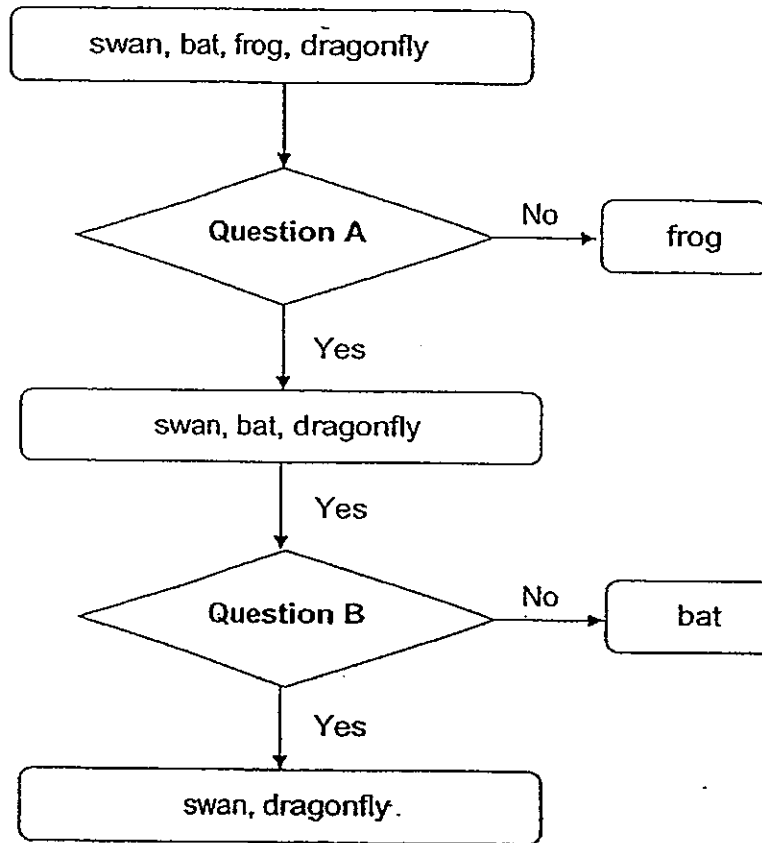

Which one of the following correctly represents question A and B in the above flowchart?

|     | Question A          | Question B                      |
|-----|---------------------|---------------------------------|
| (1) | Does it have wings? | Does it lay eggs?               |
| (2) | Does it reproduce?  | Does it have wings?             |
| (3) | Does it have wings? | Does it take care of its young? |
| (4) | Does it lay eggs?   | Does it take care of its young? |

18. The bar graph below shows the maximum weight four different types of bags, A, B, C and D, can hold before tearing.

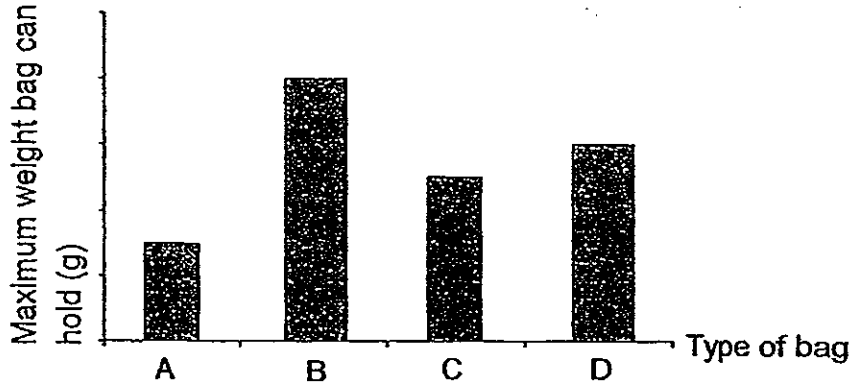

Based on the graph above, which one of the following statements about the bags is true?

- (1) Bag B is the hardest.
  - (2) Bag A is the least flexible.
  - (3) Bag C is harder than bag A.
  - (4) Bag D is stronger than bag C.
19. The table below shows the results of the scratch test for four different materials A, B, C and D.

| Results                   |
|---------------------------|
| A can scratch B, C and D. |
| B cannot scratch C.       |
| C can scratch D.          |

Based on the results given above, what materials are A, B, C and D most likely to be?

|     | Rubber | Wood | Metal | Plastic |
|-----|--------|------|-------|---------|
| (1) | C      | B    | A     | D       |
| (2) | B      | A    | D     | C       |
| (3) | D      | C    | A     | B       |
| (4) | D      | A    | B     | C       |



20. Which one of the following objects is made from only one material?



pencil



eraser

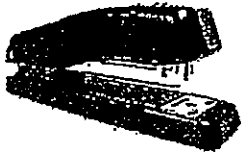

stapler



iron nail

- (1) pencil and stapler only
- (2) eraser and iron nail only
- (3) pencil, eraser and iron nail only
- (4) eraser, pencil, stapler and iron nail

21. Rubber bands are commonly used by teachers to tie stacks of worksheets together. Which one of the following properties of a rubber band best explains why it is used?

- (1) It is not hard.
- (2) It breaks easily.
- (3) It stretches easily.
- (4) It can float on water.

22. Study the table given below.

| Group A     | Group B                 |
|-------------|-------------------------|
| ceramic mug | disposable plastic fork |
| metal spoon | wooden toothpick        |
| canvas bag  | styrofoam cup           |

The things in group A and B are classified based on whether they are \_\_\_\_\_

- (1) strong
- (2) flexible
- (3) waterproof
- (4) transparent

23. Karen was blindfolded and asked to guess the object using her sense of touch. She described the object to be strong and flexible. What can the object be?

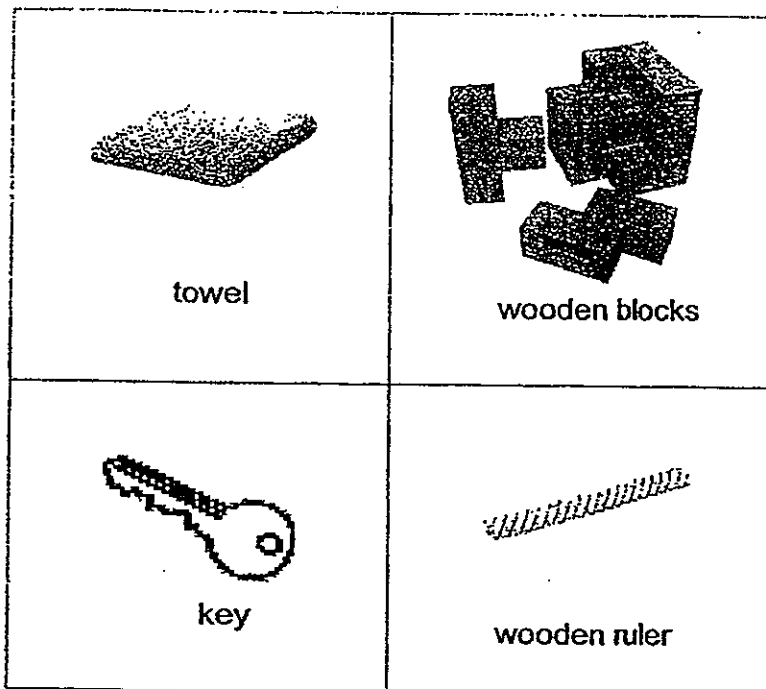

- (1) key
- (2) towel
- (3) wooden ruler
- (4) wooden blocks

24. Elite Company makes raincoats for sale.



raincoat

The table below shows the properties of 4 materials P, Q, R and S.

| Materials | Property   |             |          |       |
|-----------|------------|-------------|----------|-------|
|           | Waterproof | Transparent | Flexible | Light |
| P         |            | ✓           | ✓        |       |
| Q         | ✓          | ✓           |          |       |
| R         | ✓          |             | ✓        | ✓     |
| S         |            | ✓           | ✓        | ✓     |

Which one of the above materials, P, Q, R or S, should Elite Company choose to make their raincoats?

- (1) P
- (2) Q
- (3) R
- (4) S

25. Which one of the following materials is not suitable for making a pencil case?

- (1) glass
- (2) metal
- (3) fabric
- (4) plastic

26. The picture below shows a hammer.

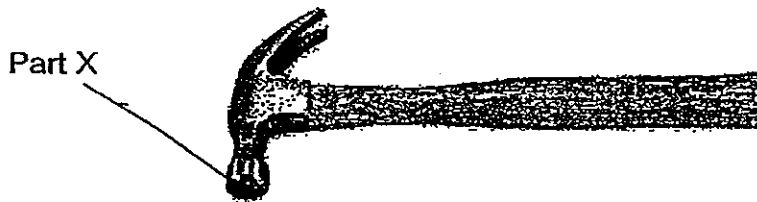

Part X of the hammer is usually made of metal. Which one of the following statements best explains why metal is used to make part X?

- (1) It is waterproof.
- (2) It does not rust easily.
- (3) It is strong and does not break easily.
- (4) It is hard and can be used to scratch other materials.

27. Which one of the following groups of materials is obtained from living things only?

- (1) wood, paper, silk, soil
- (2) glass, plastic, cotton, sand
- (3) silk, natural rubber, cotton, wool
- (4) plastic, wood, natural rubber, iron

28. The properties of 4 different bags, A, B, C and D, are shown in the table below.

| Property \ Bag | Bag A | Bag B | Bag C | Bag D |
|----------------|-------|-------|-------|-------|
| Strong         | X     | X     | √     | √     |
| Light          | √     | X     | X     | √     |
| Waterproof     | √     | √     | √     | X     |

Which one of the above bags, A, B, C or D, should Francis choose for a 5-day hike in a dense forest in Malaysia?

- (1) Bag A
- (2) Bag B
- (3) Bag C
- (4) Bag D

29. The diagram below shows a cooking pot.

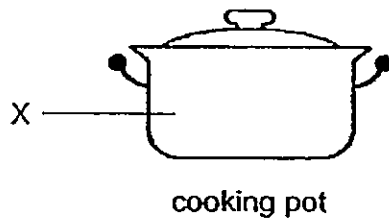

Which one of the following materials would not be suitable for making part X of the cooking pot shown above?

- (1) steel
- (2) glass
- (3) wood
- (4) ceramics

30. The diagram below shows a roll of paper towel. The paper towel is used in the kitchen to wipe spills.



Which of the following properties of paper is/are important for it to be used for making the paper towel?

- A Paper is flexible.
  - B Paper absorbs liquid.
  - C Paper can be dyed to other colours.
  - D Paper allows some light to pass through.
- (1) A only  
(2) A and B only  
(3) B and C only  
(4) C and D only

**End of booklet A**

Name: \_\_\_\_\_ ( )

Class: Primary 3 \_\_\_\_\_

## CHIJ ST NICHOLAS GIRLS' SCHOOL

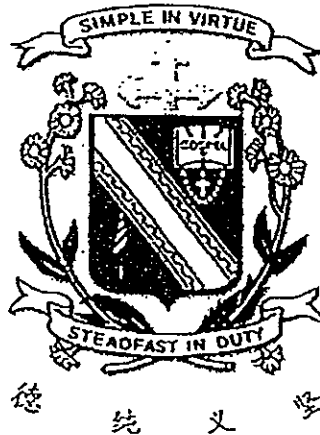

Primary 3

Semestral Assessment One

SCIENCE

BOOKLET B

15 May 2013

Total Time for Booklets A and B: 1 h 45 min

14 Questions  
40 Marks

Do not open this booklet until you are told to do so.  
Follow all instructions carefully.

This booklet consists of 11 printed pages.

|           |    |
|-----------|----|
| Booklet A | 60 |
| Booklet B | 40 |
| Total     |    |

\_\_\_\_\_  
Parent's Signature/Date

**Section B : (40 marks)**

For questions 31 to 44, write your answers in this booklet. The number of marks available is shown in the bracket [ ] at the end of each question or part question.

31. Look at the pictures given below carefully.

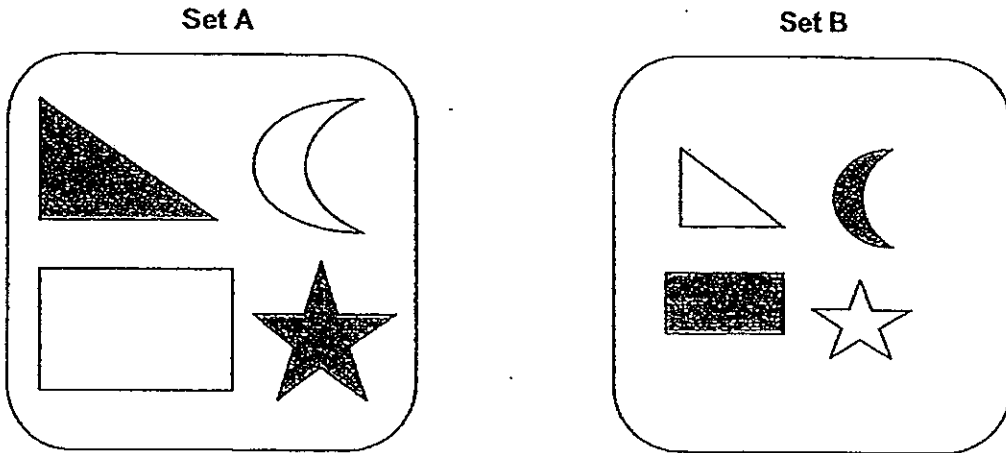

(a) The objects in sets A and B are grouped according to \_\_\_\_\_ [1]

(b) Using the same objects above, draw to show how you would group them in C and D, using another characteristic, such that there is an equal number of objects in each group. [2]

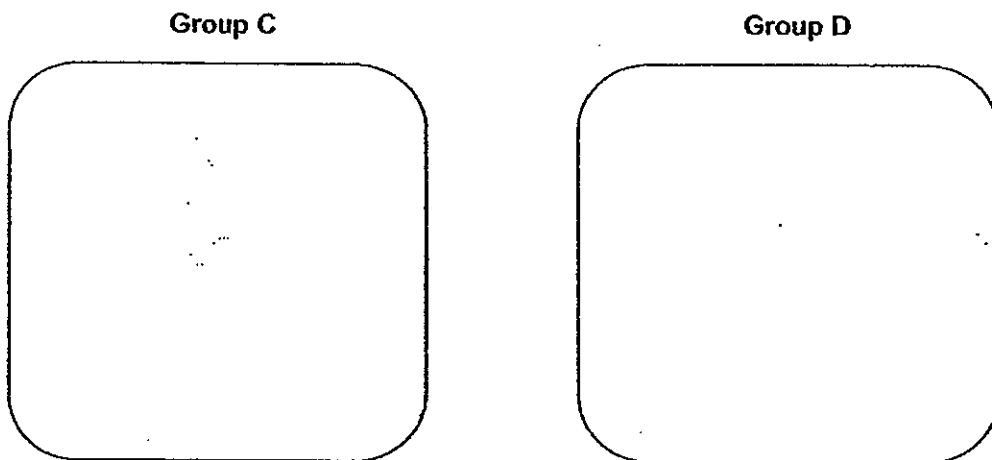

(c) Based on your answer in (b), write down the headings for groups C and D.

Group C: \_\_\_\_\_ [½]

Group D: \_\_\_\_\_ [½]





32. The flowchart below shows how four different animals, G, H, J and K, are classified.

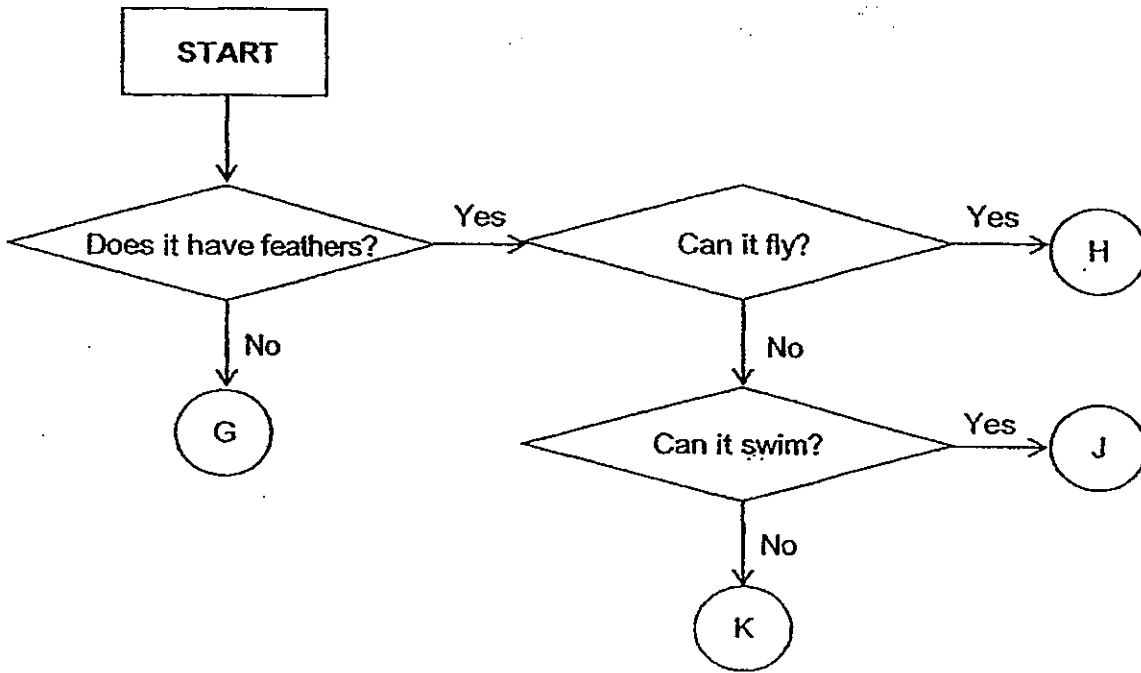

Based on the flowchart above, identify the four animals, G, H, J and K, using the names provided in the box below. [2]

|     |         |         |        |
|-----|---------|---------|--------|
| bee | ostrich | penguin | parrot |
|-----|---------|---------|--------|

- (a) Animal G: \_\_\_\_\_
- (b) Animal H: \_\_\_\_\_
- (c) Animal J: \_\_\_\_\_
- (d) Animal K: \_\_\_\_\_



33. Shuling planted an equal number of seeds in pots A, B and C as shown below.

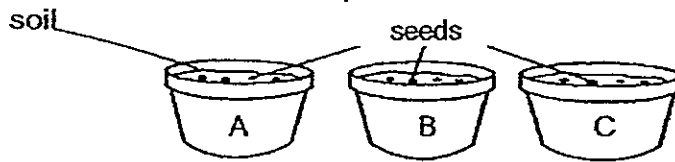

She had two boxes Y and Z as shown below.

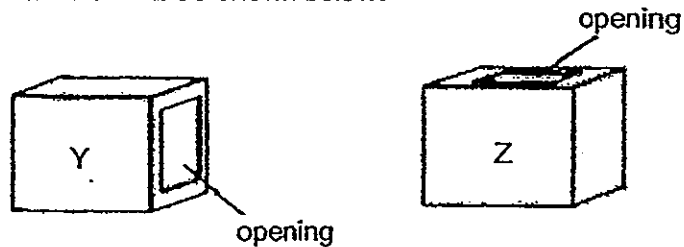

She placed pot A into box Y and pot B into box Z. She left pot C in the open and the plants in pot C grew as shown below.



Three days later, she took out pots A and B from the boxes and she observed the plants growing.

(a) Draw in the diagram below to show how the plants in pots A and B would have grown. [2]



(b) Based on your drawing in (a), explain why the plants in pot A were growing that way. [1]

---



---



34. Sarah wanted to find out the type of vegetables snails like to eat the most. She placed the same number of cabbage, lettuce, spinach and broccoli in each corner of a glass tank before placing 20 snails of the same species in the centre of the glass tank as shown below.

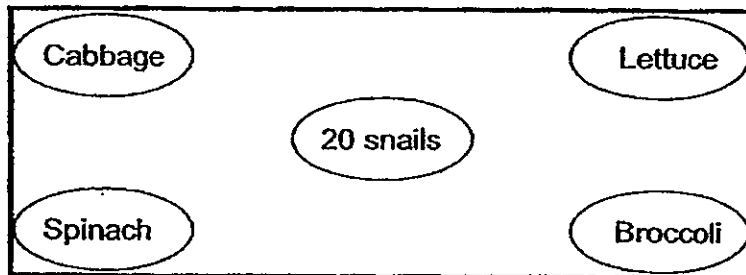

She checked all the plants daily over 4 days and recorded the number of snails she found on these plants in a table as shown below.

| Day   | Number of snails found |         |         |          |
|-------|------------------------|---------|---------|----------|
|       | Cabbage                | Lettuce | Spinach | Broccoli |
| Day 1 | 1                      | 1       | 2       | 3        |
| Day 2 | 3                      | 2       | 8       | 7        |
| Day 3 | 3                      | 2       | 8       | 7        |
| Day 4 | 3                      | 2       | 8       | 7        |

- (a) Based on the results in the above table, state 2 vegetables that the snails seem to like the most. [1]

---

- (b) If all the vegetables were removed from the glass tank except cabbage, how do you think the 20 snails will respond? Explain your answer. [2]

---

---



35. The picture below shows an ant. Write down the names of the parts labeled W, X, Y and Z. [2]

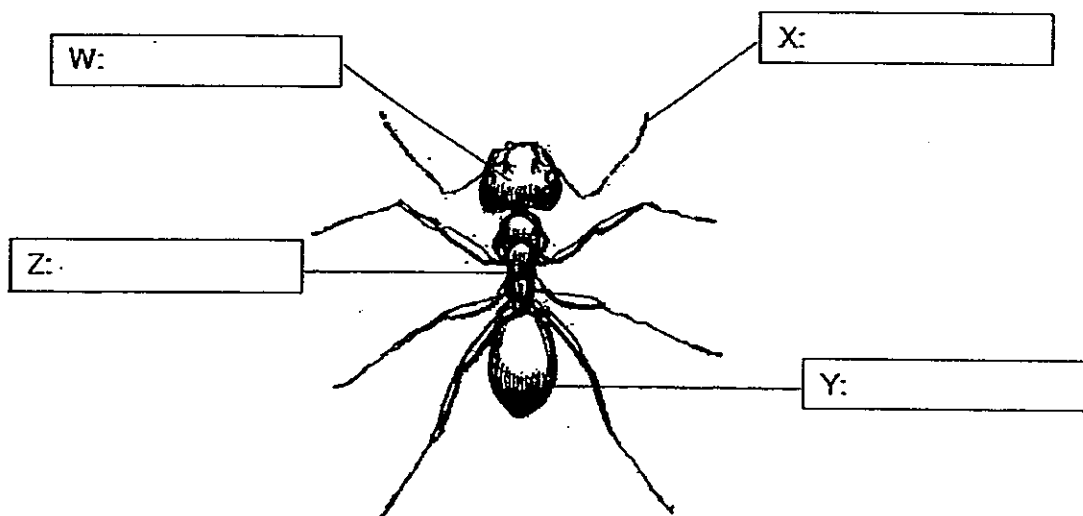

36. Michael observed the height of a bean plant over 5 weeks and he recorded his observations in the table below.

|                    |   |   |    |    |    |
|--------------------|---|---|----|----|----|
| <b>Week</b>        | 1 | 2 | 3  | 4  | 5  |
| <b>Height (cm)</b> | 2 | 5 | 8  | ?  | 14 |
| <b>Mass (g)</b>    | 3 | 7 | 12 | 17 | 23 |

- (a) Suggest what the height of the bean plant would be at the end of week 4? [1]
- \_\_\_\_\_
- (b) Michael's observation shows that living things can \_\_\_\_\_ [1]
- (c) Based on the above data, state how the mass of the plant changes over time. [1]
- \_\_\_\_\_



37. The diagram below shows two animals A and B.

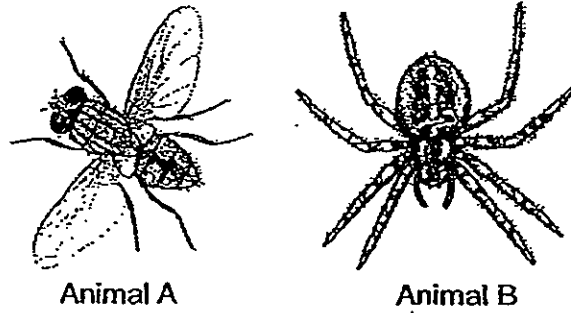

Based on what is observable in the diagram above, state two differences in physical characteristics between animal A and B. (Do not mention size, eyes and feelers.) [2]

- (a) \_\_\_\_\_  
 \_\_\_\_\_
- (b) \_\_\_\_\_  
 \_\_\_\_\_

38. Shuning kept three similar lizards in three separate jars P, Q and R as shown below.

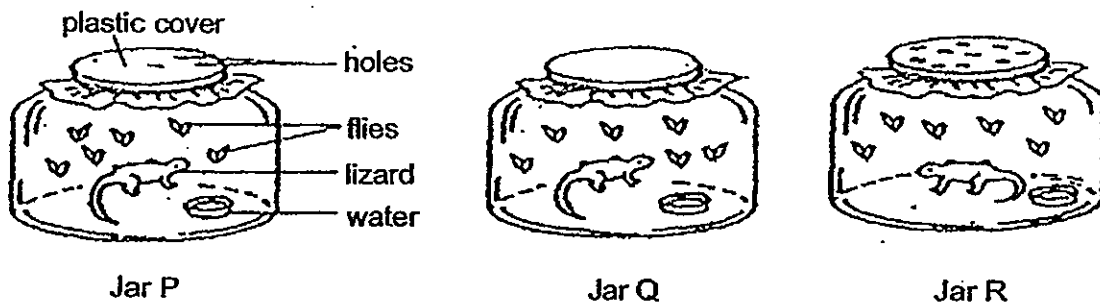

(a) Which is the most suitable way of keeping the lizard? [1]

\_\_\_\_\_

(b) Explain your answer in (a). [2]

\_\_\_\_\_  
 \_\_\_\_\_



39. The diagram below shows a bicycle.

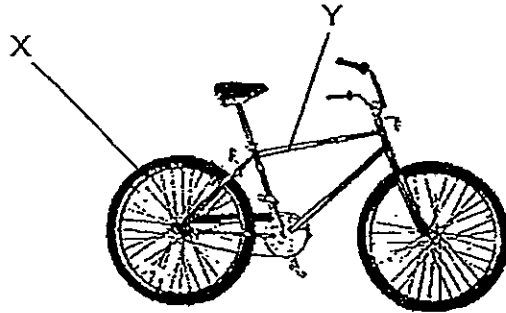

(a) Suggest what materials can be used to make part X and Y of the bicycle. [2]

Part X: \_\_\_\_\_ Part Y: \_\_\_\_\_

(b) State a property of the material that you have chosen to make part Y and explain why it is suitable. [2]

\_\_\_\_\_  
\_\_\_\_\_

40. The table below shows the properties of 4 different materials, W, X, Y and Z. A tick (✓) indicates the presence of the property.

| Properties                               | Material |   |   |   |
|--|----------|---|---|---|
|  | W        | X | Y | Z |
| It looks shiny when polished.            | ✓        |   |   |   |
| It breaks easily when hit with a hammer. |          | ✓ | ✓ |   |
| It is waterproof.                        | ✓        | ✓ |   |   |
| It can float on water.                   |          |   |   | ✓ |
| It is transparent.                       |          |   | ✓ | ✓ |

(a) Based on the table above, how is material W different from the other materials? [1]

\_\_\_\_\_

(b) Based on the table above, suggest which material, W, X, Y or Z, is most suitable for making a key. [1]

\_\_\_\_\_



41. Jaylit placed a piece of material A over two supports as shown in the diagram below. Weights of the same mass were then hung in the middle of the material until it broke. He then repeated the experiment using materials B, C and D.

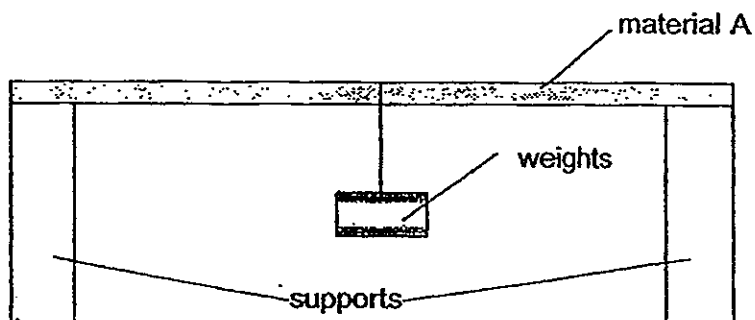

The bar graph below shows the number of weights it took to break each piece of material.

Number of weights

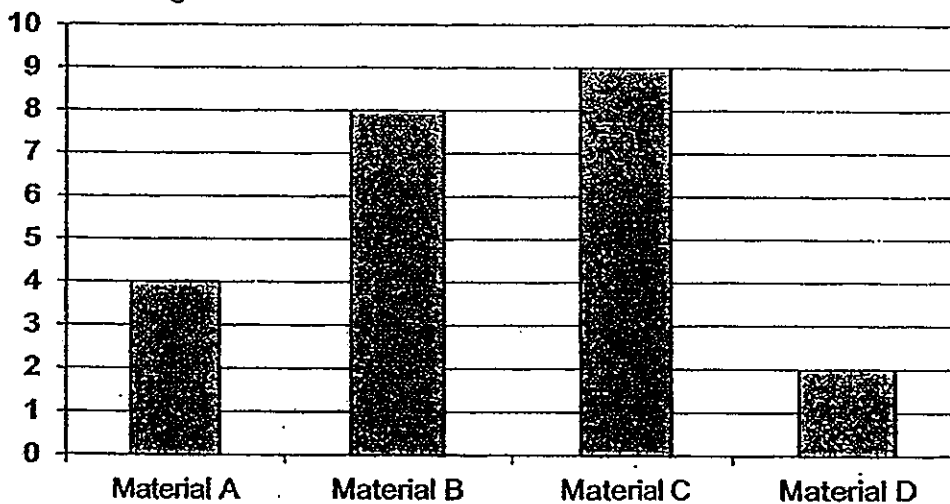

- (a) Which material, A, B, C or D, should Jaylit choose to make a table? [1]

---

- (b) Explain your answer in (a). [2]

---

---



42. The diagram below shows a pair of spectacles. The part marked X is made of glass.

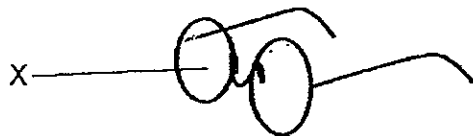

(a) Suggest another material suitable for making part X. [1]

---

(b) What is an important characteristic of the material suggested in (a) that makes it more suitable than glass for making part X? [1]

---

43. Ginny had just finished swimming and wanted a bag to contain her swimming costume. She was offered 2 bags of the same mass by her friend as shown below.



plastic bag



paper bag

(a) Which bag should Ginny choose? [1]

---

(b) State a property of the bag chosen in (a) and explain why it is better able to meet Ginny's needs. [2]

---

---





44. Study the flowchart given below.

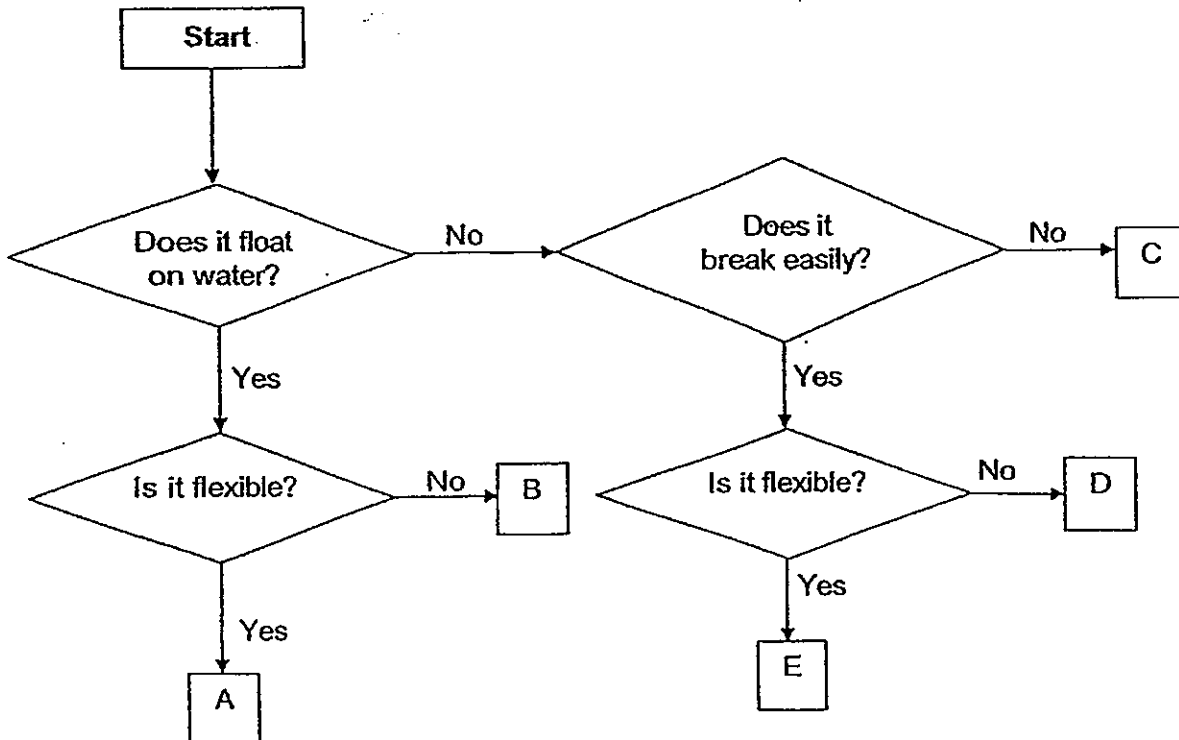

(a) Based on the above flowchart, state a similarity and a difference between objects A and E. [2]

Similarity: \_\_\_\_\_

Difference: \_\_\_\_\_

(b) Using information from the above flowchart, identify the letters, A, B, C, D or E, that best represents each of the following objects. Use each letter once only. [2]

| Object             | Letter |
|--------------------|--------|
| Screw              |        |
| Mirror             |        |
| Plastic straw      |        |
| Plastic bottle cap |        |

End of Paper  
11

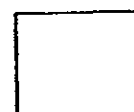

# ANSWER SHEET

**EXAM PAPER 2013**

**SCHOOL : CHIJ ST NICHOLAS GIRLS' SCHOOL**

**SUBJECT : PRIMARY 3 SCIENCE**

**TERM : SA1**

|    |    |    |    |    |    |    |    |    |     |     |     |     |     |     |     |     |
|----|----|----|----|----|----|----|----|----|-----|-----|-----|-----|-----|-----|-----|-----|
| Q1 | Q2 | Q3 | Q4 | Q5 | Q6 | Q7 | Q8 | Q9 | Q10 | Q11 | Q12 | Q13 | Q14 | Q15 | Q16 | Q17 |
| 3  | 3  | 4  | 2  | 3  | 1  | 2  | 4  | 2  | 2   | 3   | 3   | 4   | 2   | 2   | 4   | 1   |

|     |     |     |     |     |     |     |     |     |     |     |     |     |
|-----|-----|-----|-----|-----|-----|-----|-----|-----|-----|-----|-----|-----|
| Q18 | Q19 | Q20 | Q21 | Q22 | Q23 | Q24 | Q25 | Q26 | Q27 | Q28 | Q29 | Q30 |
| 4   | 3   | 2   | 3   | 1   | 2   | 3   | 1   | 3   | 3   | 3   | 3   | 2   |

Section B

Q31

a) size

b)

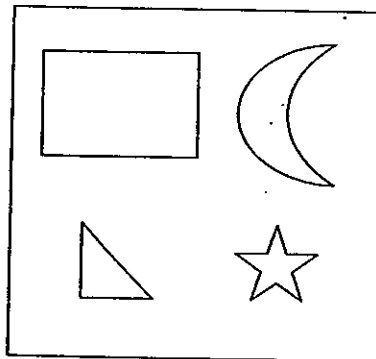
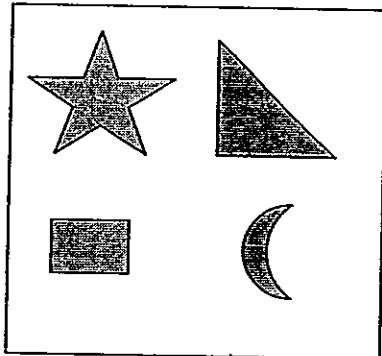

c) C: Shapes with colour

D: Shapes without any colour

Q32

a) G: Bee

b) H: Parrot

- c) J: Penguin
- d) K: Ostrich

Q33

a)



b) Plants need sunlight to grow, as Plant A is not getting enough sunlight, it will grow towards the sunlight

Q34

- a) Spinach and Broccoli
- b) All twenty snails will eat the cabbage, as snails need food to survive

Q35) W: Head

Z: Torso

X: Feelers

Y: Abdomen

Q36

- a) 11cm
- b) grow
- c) As the plant grows taller, more weight is added

Q37

- a) Animal A has six legs while Animal B has eight legs.
- b) Animal A has wings while Animal B has no wings

Q38

- a) Jar R is the most suitable
- b) There is more air coming in as there are more holes than Jar P and Q.

Q39

- a) X: Rubber, Y: metal
- b) Part Y need to be strong and durable to hold the weight of the cyclist. Metal is a strong material and thus it is suitable.

Q40

- a) Material W look shiny when polished while the other material don't look shiny when polished
- b) Material W

Q41

- a) Material C
- b) C holds the most number of weights, showing that C is the strongest.

Q42

- a) Clear Plastic
- b) Plastic cannot break as easily as glass, and thus is more suitable

Q43

- a) The plastic Bag
- b) The plastic bag is waterproof. Ginny's swimming clothes is wet and when she put it into the plastic bag, water will not drip out

Q44

- a) Similarity: Both A and E are flexible  
Difference: A floats in water while E does not
- b)

| Object             | Letter |
|--------------------|--------|
| Screw              | C      |
| Mirror             | D      |
| Plastic straw      | A      |
| Plastic bottle cap | B      |





HENRY PARK PRIMARY SCHOOL  
2013 SEMESTRAL EXAMINATION 1  
SCIENCE PRIMARY 3

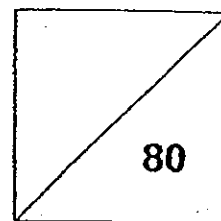

Duration of Paper: 1 h 30 min

Name: \_\_\_\_\_ ( )

Parent's Signature: \_\_\_\_\_

Class: Pr 3 \_\_\_\_\_

**Section A**

For each question from 1 to 20, four options are given. One of them is the correct answer. Make your choice (1, 2, 3 or 4). Shade the correct oval (1, 2, 3 or 4) on the Optical Answer Sheet (OAS).

1. Which of the following statements show that living things respond to changes around them?

- A: A cat ran away when it saw a dog nearby.
- B: Halim moved his hand away from a glass of hot milk.
- C: Sally shut her eyes when she heard loud thunder.

- (1) A only
- (2) A and B only
- (3) B and C only
- (4) A, B and C

( )

2. Which one of the following pictures shows the correct drawing of an insect?

(1)

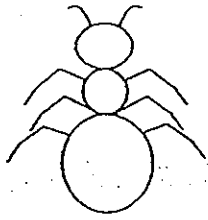

(3)

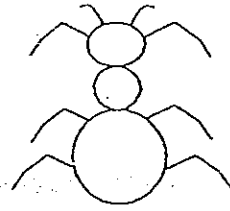

(2)

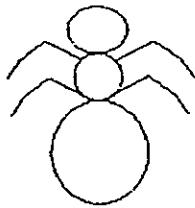

(4)

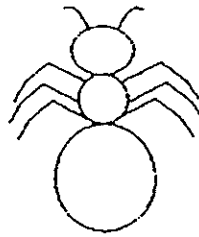

( )

3. Study the diagram below.

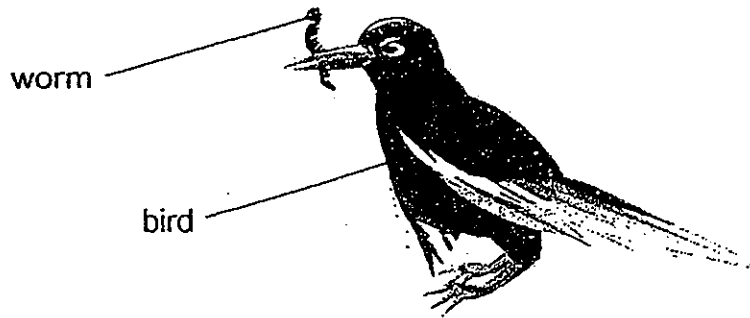

Which characteristic of living things does the bird show by feeding on the worm?

- (1) Living things grow.
- (2) Living things need air.
- (3) Living things need food.
- (4) Living things reproduce.

( )

4. Study the diagram below carefully.

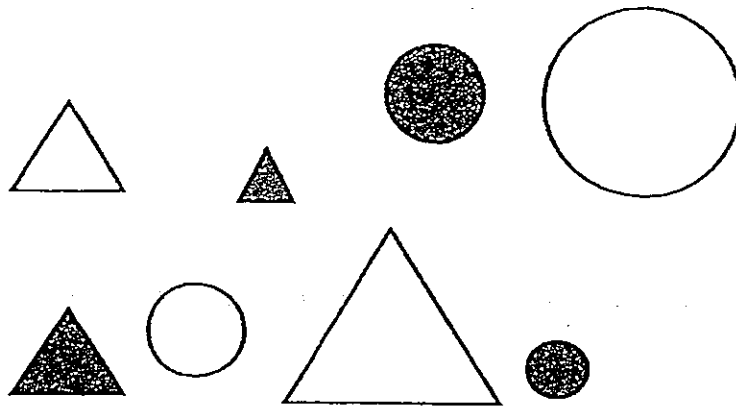

How can the objects in the diagram above be classified?

- (1) By size only
- (2) By colour only
- (3) By shape and size only
- (4) By shape, colour and size

5. Study the 3 organisms below carefully.



A: Fern



B: Flowering Plant



C: Fungi

Which statement below describes the organisms above correctly?

- (1) Organisms A, B and C make their own food.
- (2) Organisms A and B bear flowers but C does not.
- (3) Organisms A and C make their own food but B does not.
- (4) Organisms A and B make their own food but C does not.



6. Zahar conducted an experiment using 4 similar slices of bread to find out how quickly bread mould will grow in different conditions.

|   | Condition of place where bread is placed | Amount of moisture on bread |
|---|--|-----------------------------|
| A | Cold                                     | Low                         |
| B | Warm                                     | High                        |
| C | Warm                                     | Very Low                    |
| D | Very Cold                                | Very Low                    |

On which bread will he see the most amount of bread mould after 6 days?

- (1) A
- (2) B
- (3) C
- (4) D

( )

7. The diagram below shows parts of a toadstool.

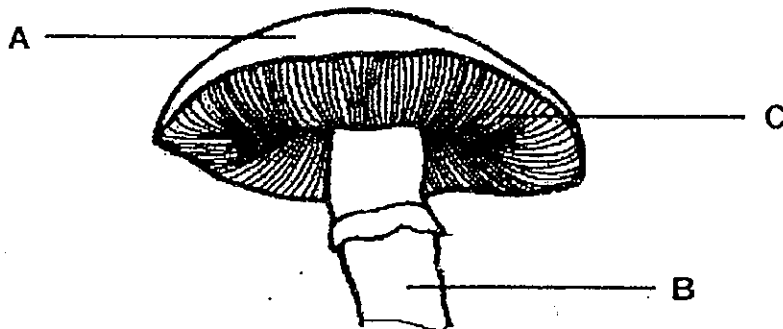

Which of the following identifies part A, B and C correctly?

|     | A     | B      | C     |
|-----|-------|--------|-------|
| (1) | Cap   | Stalk  | Gills |
| (2) | Gills | Cap    | Stalk |
| (3) | Cap   | Spores | Stalk |
| (4) | Cap   | Spores | Gills |

( )

8. Mina had 2 similar objects that were equally heavy. She put one object into Bag X and the other into Bag Y. Bags X and Y were made of different materials. After some time, Bag X broke from the weight of the object but Bag Y did not break.

What can Mina conclude about Bag X?

- (1) Bag X is not as hard as Bag Y
- (2) Bag X is not as light as Bag Y
- (3) Bag X is not as strong as Bag Y
- (4) Bag X is not as flexible as Bag Y ( )

9. Mrs Lee uses the water hose to water the plants in her garden.

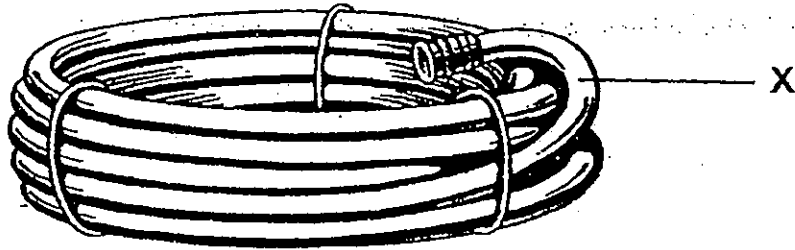

**Water hose**

Mrs Lee is able to roll up her water hose as shown above because the material used to make part X is \_\_\_\_\_.

- (1) hard
- (2) light
- (3) strong
- (4) flexible ( )

10. The table below shows how some animals are classified according to their characteristics.

| Lives on land   |            |                      |                 |
|-----------------|------------|----------------------|-----------------|
| Eats insects    |            | Does not eat insects |                 |
| Can fly         | Cannot fly | Can fly              | Cannot fly      |
| <b>Animal S</b> |            |                      | <b>Animal T</b> |

Based only on the classification table above, which of the following statements correctly describe the differences between Animals S and T?

- A: Animal S can fly while Animal T cannot fly.
- B: Animal S eats insects while Animal T does not eat insects.
- C: Animal T lives on land while Animal S does not live on land.

- (1) A only
- (2) A and B only
- (3) A and C only
- (4) B and ~~D~~ only

( )

11. Roy caught 2 different animals, X and Y, which can fly. He identifies correctly that only animal X is an insect.

Which of the following characteristics helped Roy identify animal X as an insect?

- A: Animal X has wings.
- B: Animal X has 6 legs.
- C: Animal X lays eggs.
- D: Animal X has 3 body parts.

- (1) A and D only
- (2) B and D only
- (3) A, B and C only
- (4) B, C and D only

( )

12. The table below shows the characteristics of 4 animals, S, T, U and V.

Which animal, S, T, U or V, is a bird?

|     | Animals | Lay eggs | Has feathers | Live in water | Has wings |
|-----|---------|----------|--------------|---------------|-----------|
| (1) | S       | X        | X            | ✓             | X         |
| (2) | T       | ✓        | X            | X             | ✓         |
| (3) | U       | ✓        | ✓            | X             | ✓         |
| (4) | V       | ✓        | X            | ✓             | X         |

( )

**A (✓) means it has the characteristics and a (X) means it does not.**

13. The flow chart below shows classification of animals into 4 groups, P, Q, R and S.

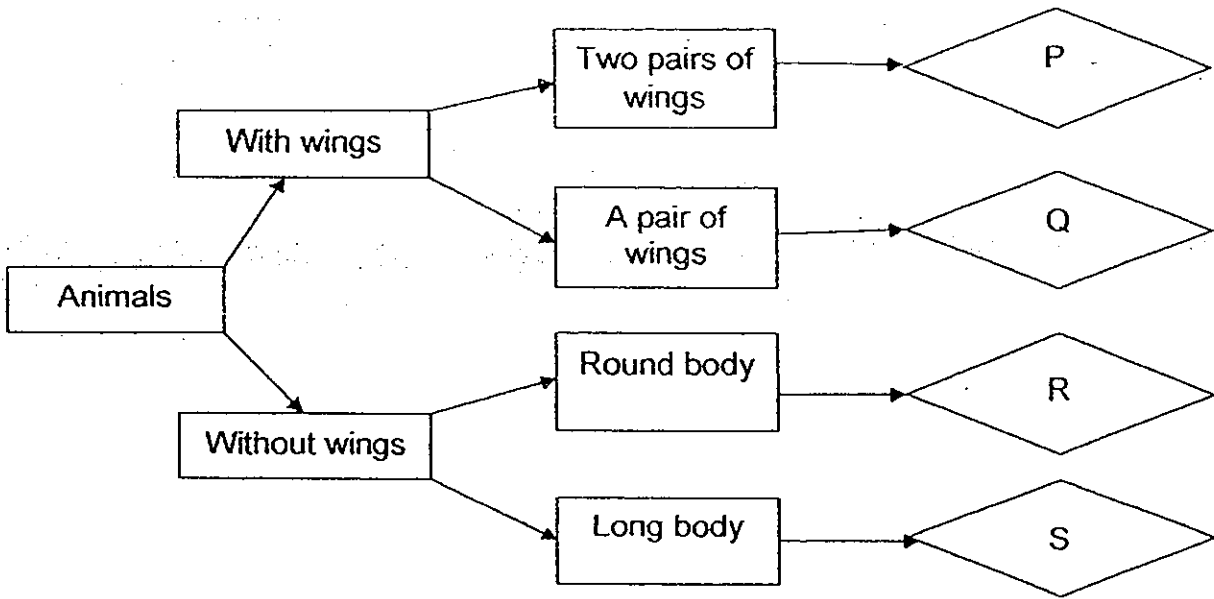

Using the information from the flow chart above, which of the following groups is Animal A likely to be in?

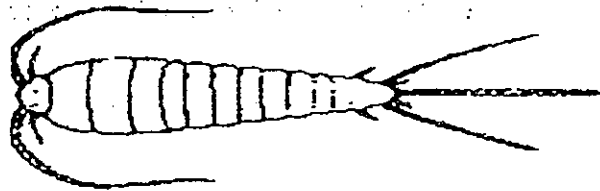

Animal A

- (1) Group P
- (2) Group Q
- (3) Group R
- (4) Group S

( )

14. Jenny compared the hardness of 3 containers, A, B and C shown below by scratching them with an iron nail.

She then recorded her observations in the table below, using a tick (✓) to show that there are scratch marks on the containers.

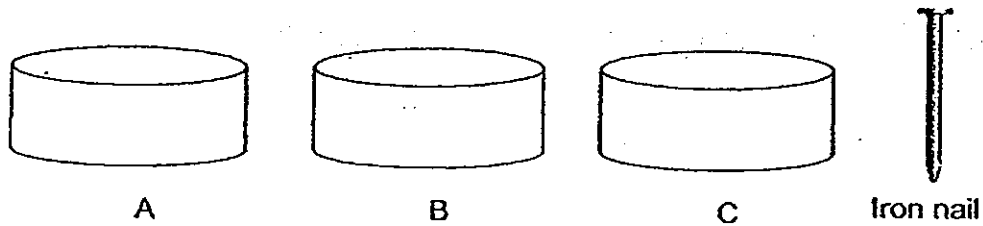

| Appearance of containers | Scratch marks found on each container |   |   |
|--------------------------|---------------------------------------|---|---|
|                          | A                                     | B | C |
| Deeply scratched         | X                                     | ✓ | X |
| Lightly scratched        | X                                     | X | ✓ |
| No scratches             | ✓                                     | X | X |

A (✓) means it has scratches and a (X) means it does not have scratches.

Based on the results above, arrange the containers from the softest to the hardest.

|     | Softest | → | Hardest |
|-----|---------|---|---------|
| (1) | A       |   | B C     |
| (2) | B       |   | C A     |
| (3) | C       |   | B A     |
| (4) | B       |   | A C     |

( )

15. Which one of the following objects is not made from parts of animals?

- (1) Leather bag
- (2) Silk scarf
- (3) Rubber ball
- (4) Woollen socks

( )

16. The diagram below shows 2 leaves that Ali picked up at the garden.

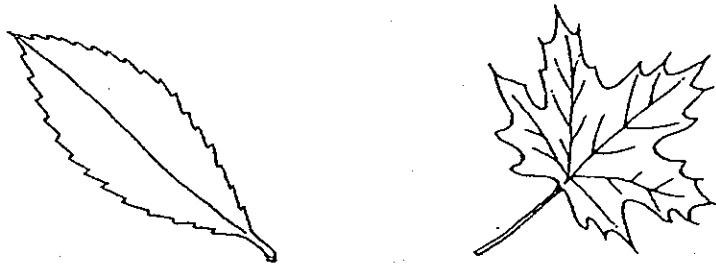

Ali classified both leaves shown above in the same group.

Look at the 3 leaves shown below.

Which of the following is/are more likely to be classified in the same group as the 2 leaves above?

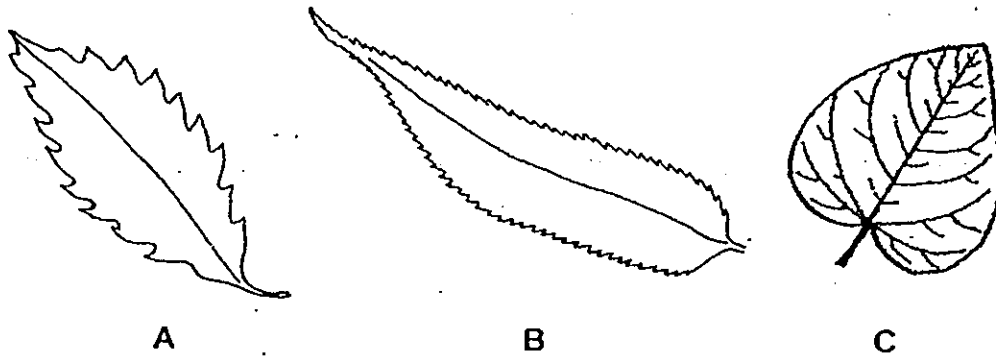

- (1) A only
- (2) C only
- (3) A and B only
- (4) B and C only

( )

17. The flow chart below shows 3 organisms, A, B and C.

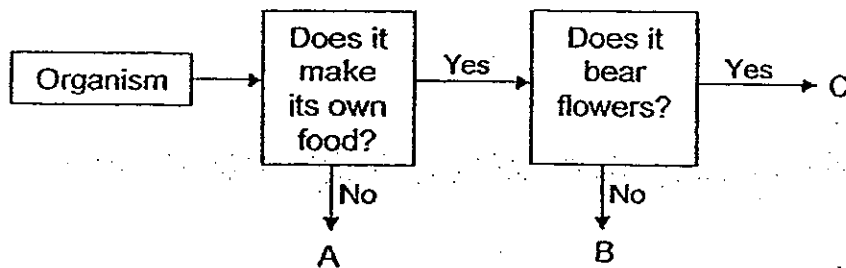

Based on the flow chart above, which of the following statements is correct?

- (1) Organism B is a flowering plant.
- (2) Organism C reproduces by spores.
- (3) Organism A is a non-flowering plant.
- (4) Both Organisms B and C are able to make their own food. ( )

18. The diagram below shows 2 flowering plants X and Y.



Plant X



Plant Y

Which of the following statements about plants X and Y is true?

- (1) Plant X needs support but plant Y does not.
- (2) Plant Y needs support but Plant X does not.
- (3) Plant X reproduces by spores but plant Y does not.
- (4) Plant X reproduces by seeds but plant Y does not. ( )



19. Nelson studied 4 plants, A, B, C and D, and recorded his observations in the table below.

| Plants | Characteristics |               |
|--------|-----------------|---------------|
|        | Bears fruit     | Grows on land |
| A      | ✓               | ✓             |
| B      | ✓               | X             |
| C      | X               | ✓             |
| D      | ✓               | ✓             |

A (✓) means it has the characteristics and a (X) means it does not.

Study the classification chart below.

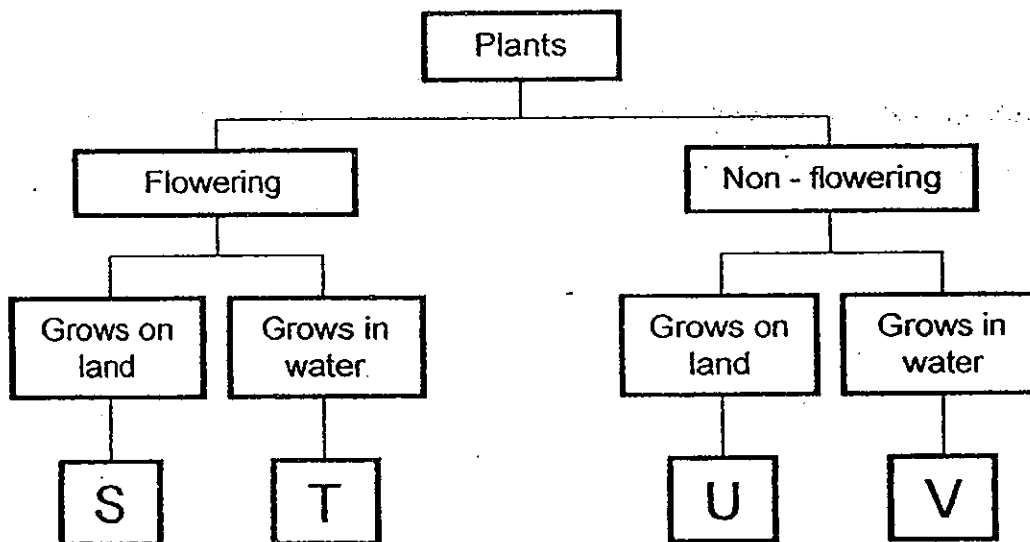

In which box, S, T, U or V, can Plant D be placed in?

- (1) S
- (2) T
- (3) U
- (4) V

( )

20. Tom found **Organism X** in his garden. He observed it for a week and wrote down his observations as shown below.

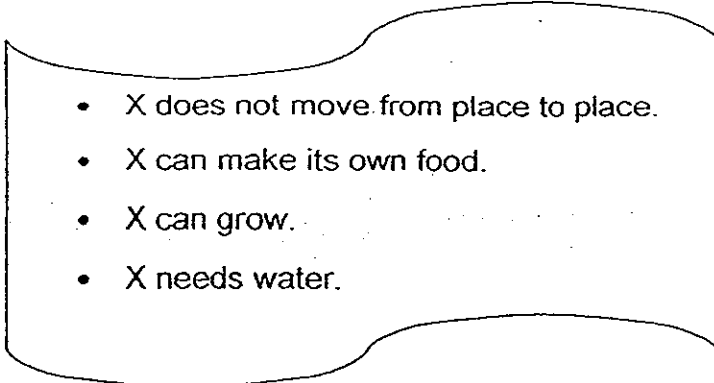
- 
- X does not move from place to place.
  - X can make its own food.
  - X can grow.
  - X needs water.

He showed Melissa his observations and she concluded immediately that **Organism X** is a plant.

Which of the following observations tells Melissa that **Organism X** is likely to be a plant?

- (1) It needs water.
- (2) It can reproduce.
- (3) It can make its own food.
- (4) It does not move from place to place.

( )

**End of Booklet A**

HENRY PARK PRIMARY SCHOOL  
2013 SEMESTRAL EXAMINATION I  
SCIENCE  
PRIMARY 3

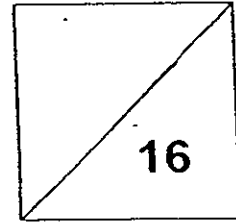

Name: \_\_\_\_\_ ( )

Class: Pr 3 \_\_\_\_\_

**Section B**

Write your answers to questions 21 to 26 in the spaces given. (16 marks)

---

21. Read the following statements carefully.

(3m)

In the spaces provided, write 'T' for sentences that are TRUE and 'F' for sentences that are FALSE.

1. All plants bear fruits.
2. Fungi reproduce by spores
3. All mammals are plant-eaters.

---

---

---

22. The diagram below shows a bicycle.

(2m)

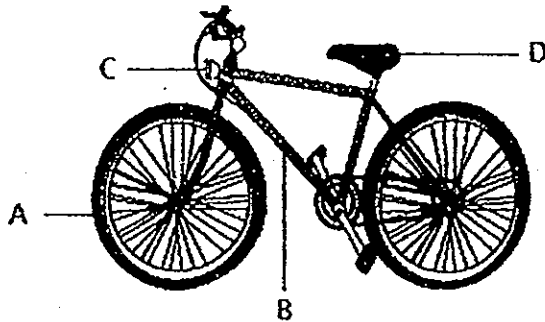

From the picture above, choose the correct parts that are made of the following materials and write the letters, A, B, C or D, in the boxes below.

|     | Material | Part of bicycle |
|-----|----------|-----------------|
| (a) | Metal    |                 |
| (b) | Rubber   |                 |

23. Study the fish tank diagram below.

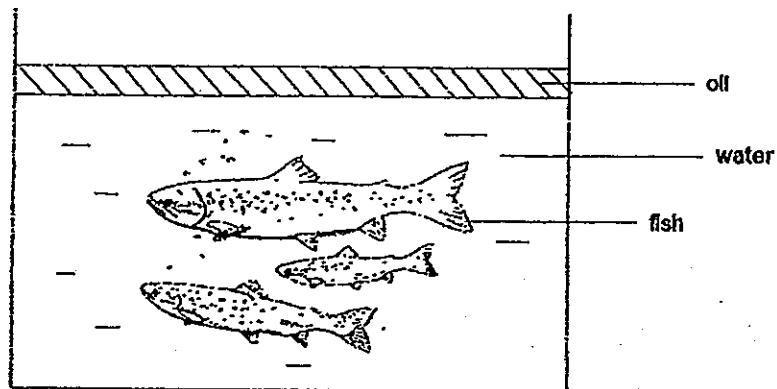

Fill in the blanks below with correct words based on the diagram above. (2m)

a) The fishes died after some time as they did not get enough \_\_\_\_\_.

b) The fishes also need \_\_\_\_\_ to survive.

24. The diagram below shows a flow chart which can be used to classify animals.

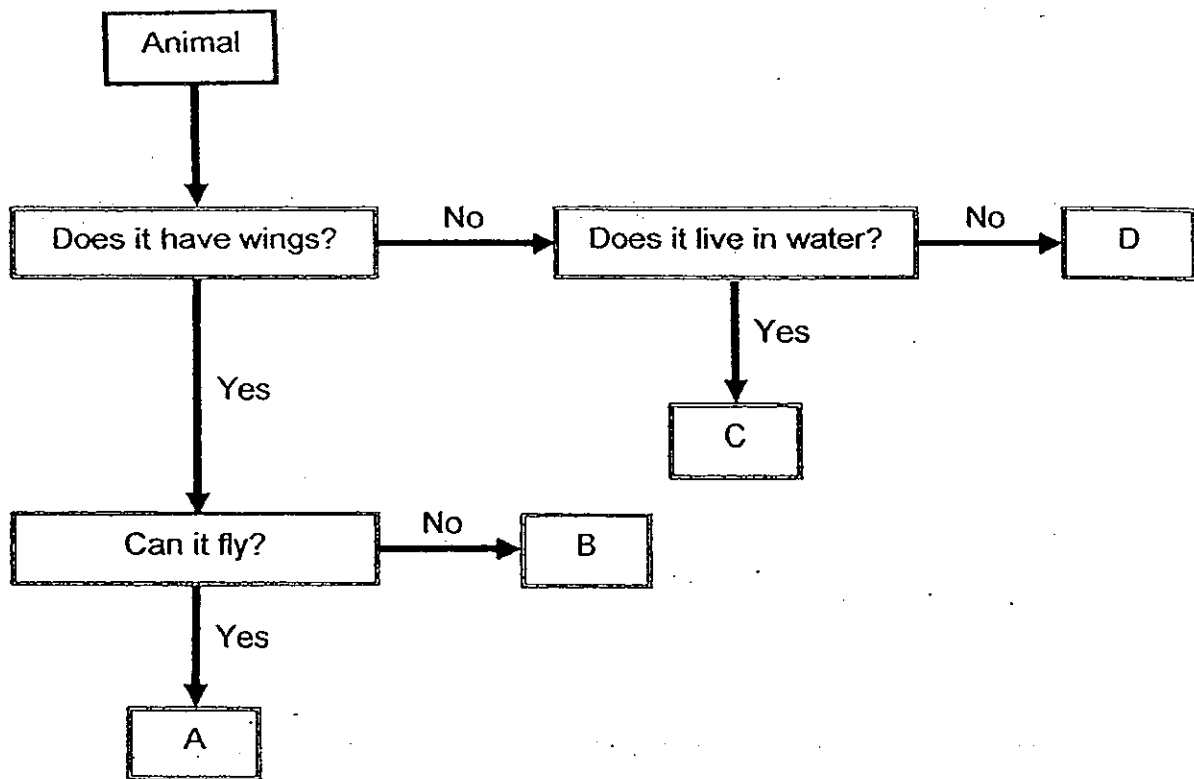

Based on the flow chart above, write the letters, A, B, C or D, that represents the following 3 animals in the correct boxes below. (3m)

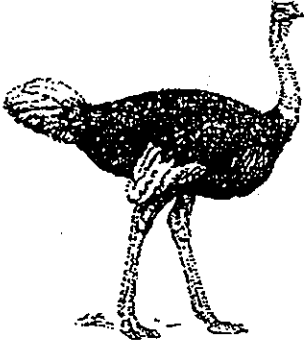
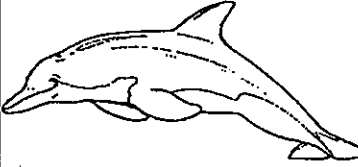
|   |   |  |
|---|---|--|
|  |  |  |
|   |   |  |

25. The flow chart below shows the characteristics of 5 different kinds of leaves.

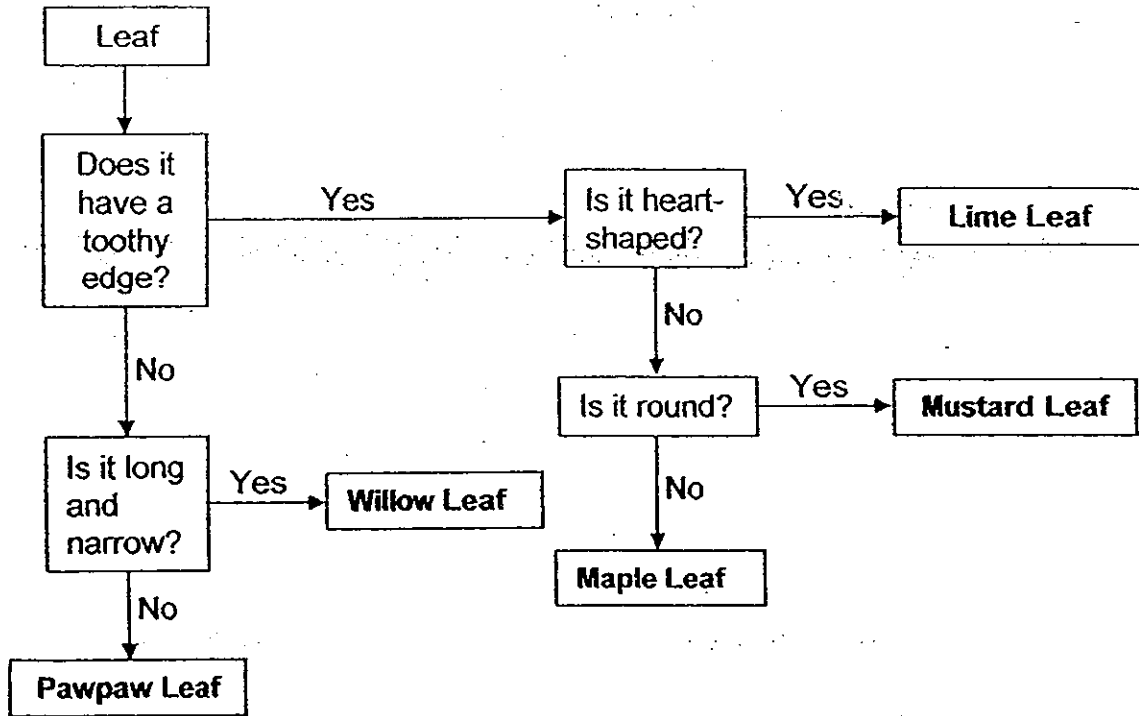

Use the flow chart to identify and write the names of the following 3 leaves A, B and C. (3m)

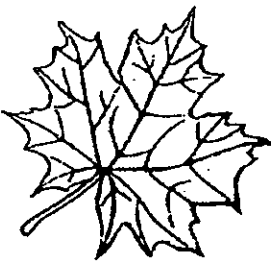
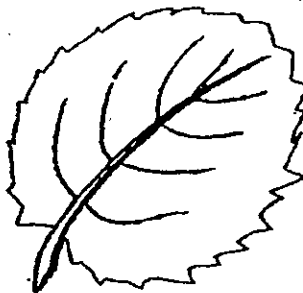
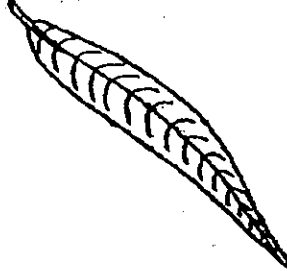
| Leaf A  | Leaf B  | Leaf C   |
|---|---|--|
|  |  |  |
|   |   |  |

26. Study the flow chart of animals P, Q, R and S below carefully.

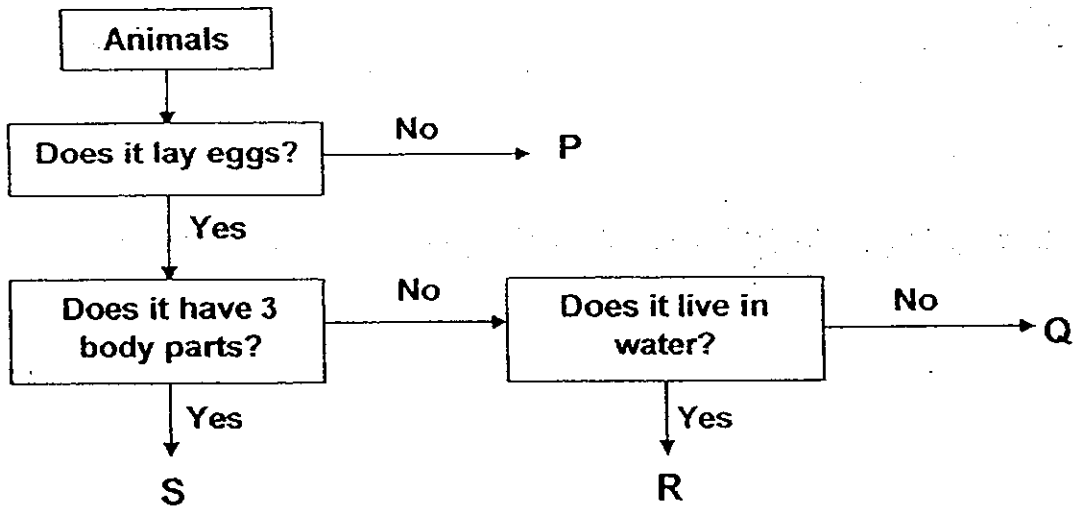

Based on the flowchart, complete the following statements by writing the correct letters P, Q, R or S in the blanks provided. (3m)

- Animal Q lays eggs but animal \_\_\_\_\_ does not lay eggs.
- Animal S has 3 body parts but animals R and \_\_\_\_\_ do not have 3 body parts.
- Animal \_\_\_\_\_ lives in the water but animal Q does not live in the water.

HENRY PARK PRIMARY SCHOOL  
2013 SEMESTRAL EXAMINATION I  
SCIENCE  
PRIMARY 3

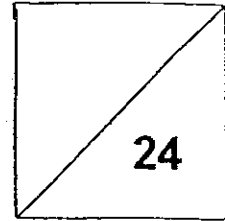

Name: \_\_\_\_\_ ( )

Class: Pr 3 \_\_\_\_\_

**Section C**

Write your answers to questions 27 to 34 in the spaces given. (24 marks)

---

27. Sean found animals A and B in his school garden. He then sketched pictures of them as shown in the diagram below.

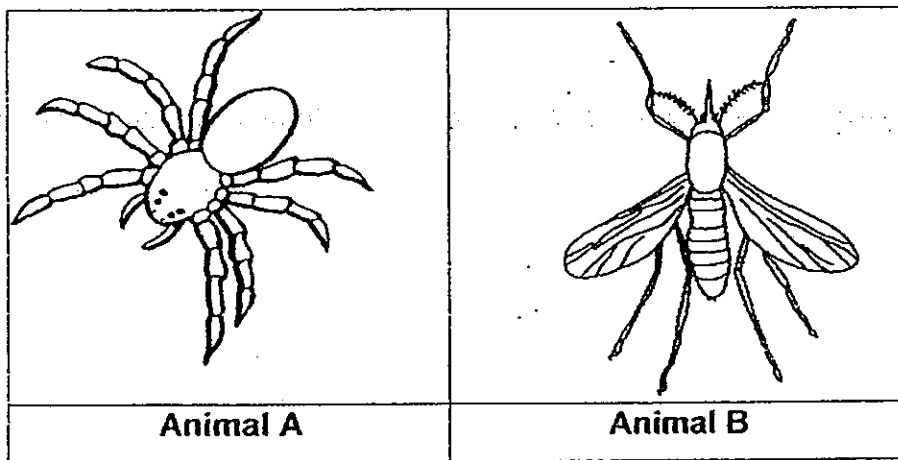

a) Which animal, A or B, is likely to be an insect? (1m)

\_\_\_\_\_

b) Explain your answer in (a). (2m)

\_\_\_\_\_

\_\_\_\_\_



28. The classification chart below shows how some animals are grouped according to their characteristics.

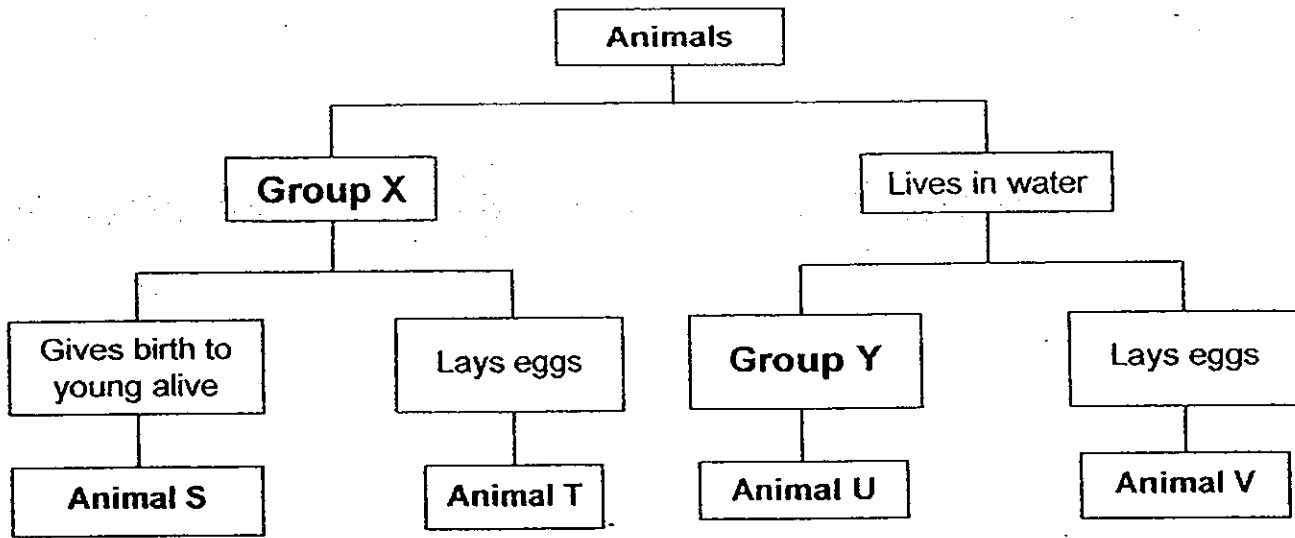

a) Based only on the classification chart above, state one similarity and one difference between animals T and V. (2m)

Similarity:

---



---

Difference:

---



---

b) Give a suitable heading for Groups X and Y. (2m)

Group X:

---

Group Y:

---

29. Mdm Lim set up the experiment shown below. She added similar iron balls into Bag A until the bag broke.

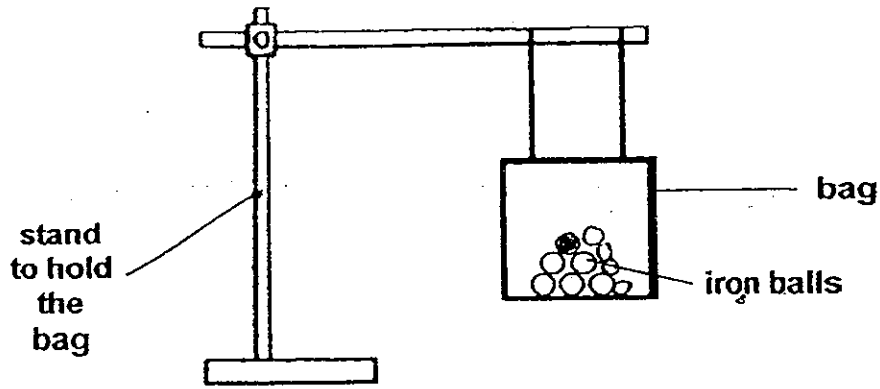

She repeated the experiment using Bag B and Bag C which were made of different materials. She recorded her observation in the table below.

|       | Number of iron balls added before the bag broke |
|-------|---|
| Bag A | 25  |
| Bag B | 13  |
| Bag C | 19  |

- a) Which bag, A, B or C is the strongest? (1m)

---

- b) Using the information from the table, explain your answer in (a). (1m)

---

---

- c) Which bag, B or C, is strong enough to hold 16 iron balls? (1m)

---

30. Tom wants to find out which material, A, B or C is the hardest. He used 3 similar sheets, made of different materials, A, B and C as shown below.

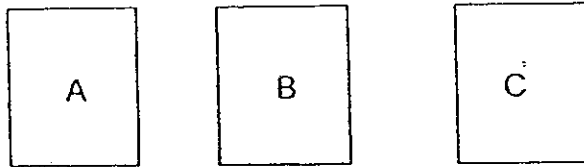

He used the same amount of strength to scratch each sheet 8 times with an iron nail and recorded the results in the table below.

| Material | Number of scratches on the material |
|----------|-------------------------------------|
| A        | 2                                   |
| B        | 6                                   |
| C        | 3                                   |

Use the results given in the table above to answer the following questions.

- a) Which material, A, B or C, is the hardest? Explain your answer. (2m)

---

---

- b) Tom scratched another similar sheet made of material D, with the iron nail 8 times. He observed 4 scratch marks on material D.

Which materials from table above are harder than Material D? (1m)

---

31. Study the flow chart which represents organisms A, B and C.

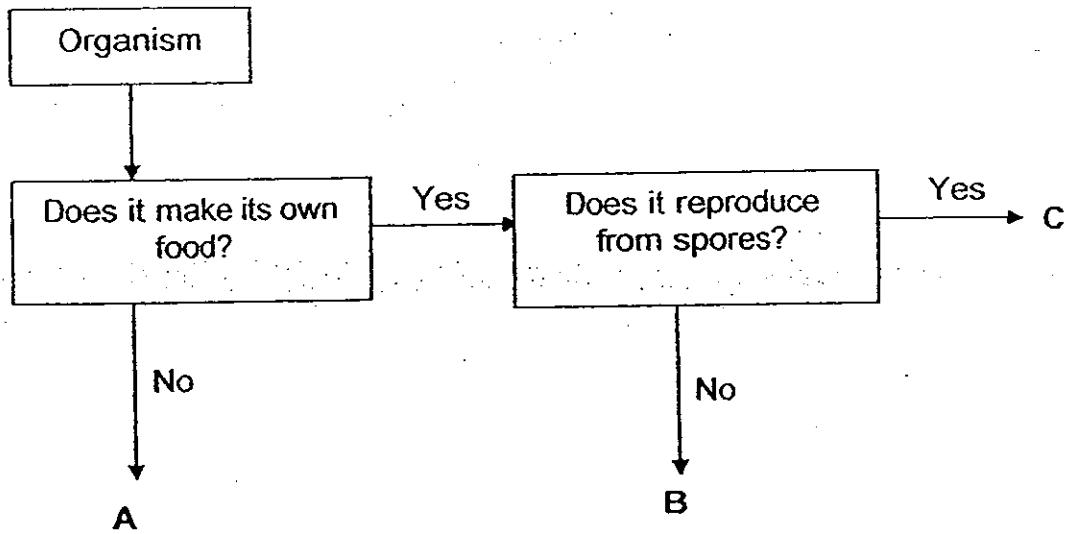

Use the information from the flow chart above to answer the following questions.

a) Describe 2 characteristics of organism C. (2m)

i)

---

ii)

---

b) Describe one difference between organisms B and C. (1m)

---

---

c) Which organism, A, B or C, is not a plant?

Explain why.

(1m)

---

---

32. Sally was taking a stroll at a park when she spotted a rotting log on the ground.

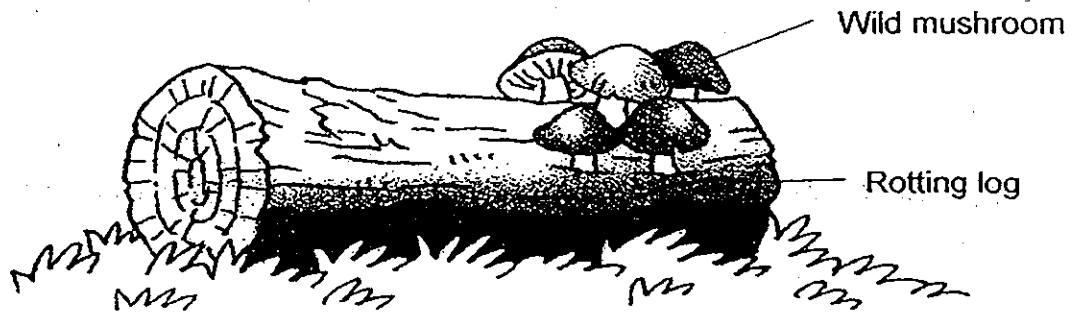

She noticed that there were wild mushrooms growing on the rotting log.

Explain clearly why wild mushrooms are usually found growing on rotting logs. (2m)

---

---

33. The diagram below shows some unknown organisms are classified in groups.

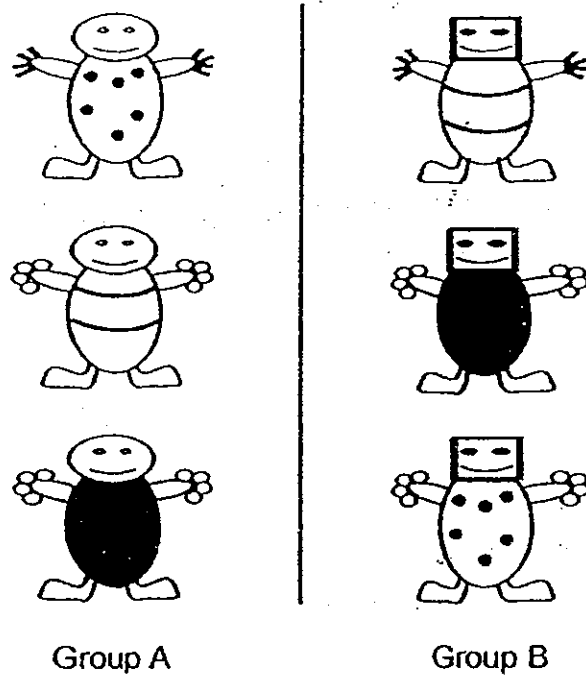

a) State 2 differences between organisms in Group A and Group B. (2m)

---

---

b) State another way these 6 organisms can be classified into 2 groups again. (1m)

---

---

34. The classification chart below shows plants P, Q, S and T.

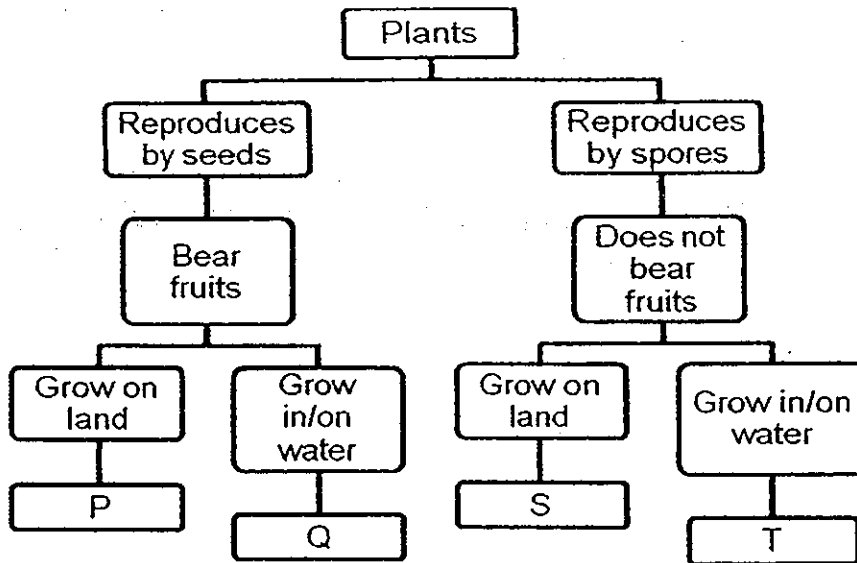

a) State 2 plants, P, Q, S and T, which bear flowers.

(1m)

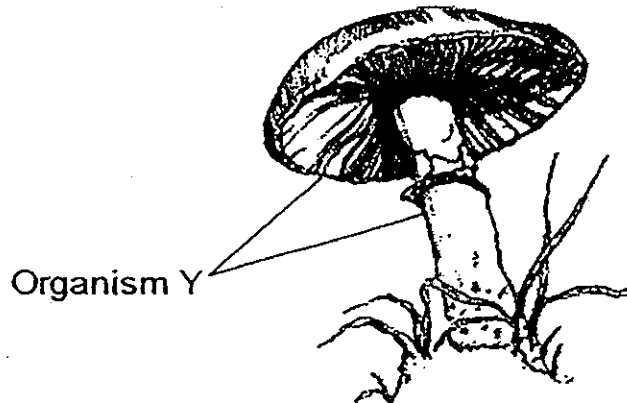

b) Look at organism Y shown above.

(1m)

Explain why organism Y cannot be placed in the classification chart above.

End of Booklet B

Setters: Mr Yuan KK and Miss Soh LH

# ANSWER SHEET

## EXAM PAPER 2013

SCHOOL : HENRY PARK PRIMARY SCHOOL

SUBJECT : PRIMARY 3 SCIENCE

TERM : SA1

---

|    |    |    |    |    |    |    |    |    |     |     |     |     |     |     |     |     |
|----|----|----|----|----|----|----|----|----|-----|-----|-----|-----|-----|-----|-----|-----|
| Q1 | Q2 | Q3 | Q4 | Q5 | Q6 | Q7 | Q8 | Q9 | Q10 | Q11 | Q12 | Q13 | Q14 | Q15 | Q16 | Q17 |
| 4  | 4  | 3  | 4  | 4  | 2  | 1  | 3  | 4  | 2   | 2   | 3   | 4   | 2   | 3   | 3   | 4   |

|     |     |     |
|-----|-----|-----|
| Q18 | Q19 | Q20 |
| 1   | 1   | 3   |

Section B

Q21) 1. F

2. T

3. F

Q22

a) B, C

b) A, D

Q23

a) Air

b) Food

Q24) D, B, C

Q25) Leaf A: Maple leaf

Leaf B: Lime leaf

Leaf C: Willow leaf



Q26

- a) P
- b) Q
- c) R

Q27

- a) Animal B is likely to be an insect
- b) It has three body parts and has six legs

Q28

- a) Similarity: Animal T and V lay eggs  
Difference: Animal V lives in water while Animal T does not live in water
- b) Group X: Lives on Land  
Group Y: Gives birth to live young

Q29

- a) Bag A is the strongest bag
- b) Bag A has the most number of iron balls before the bag broke
- c) Bag C is strong enough to hold 16 iron balls

Q30

- a) Material A. It has the least number of scratches
- b) Material C and A are stronger than Material D.

Q31

- a) i) It makes its own food  
ii) it reproduces through spores
- b) Organism B does not reproduce from spores while organism C does c) Organism A. It cannot make its own food

Q32) The log provides food for the wild mushrooms.

Q33

- a) Organisms in Group A have unshaded eyes while Group B have shaded eyes.  
Group A have round heads while organisms in Group B have square heads.
- b) Organisms with rounded fingers and organisms with rectangle fingers.

Q34

- a) Plant P and Q
- b) Organism Y is not a plant



MAHA BODHI SCHOOL  
2013 SEMESTRAL ASSESSMENT 1  
PRIMARY THREE SCIENCE

Name : \_\_\_\_\_ ( )

Date : 16 May 2013

Class : Primary 3( )

Duration : 1 h 15 min (Booklets A and B)

**BOOKLET A : [15 x 2 marks = 30 marks]**

For each question from 1 to 15, four options are given. One of them is the correct answer. Make your choice (1, 2, 3 or 4). **Shade your answer on the Optical Answer Sheet.**

1. Sam has some buttons as shown in the diagram below.

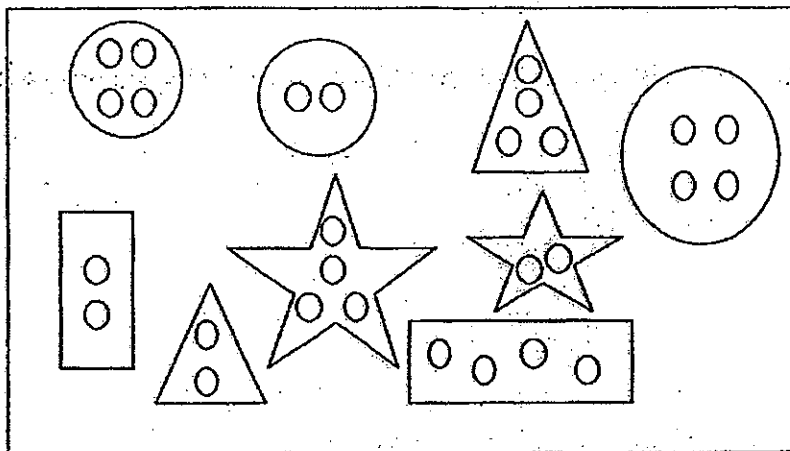

Based on the diagram, which of the following properties can be used to classify the buttons?

- A. size
- B. shape
- C. colour
- D. number of holes

- (1) A and B only
- (2) A and D only
- (3) A, B and D only
- (4) B, C and D only

2. Sam placed some pieces of paper into groups as shown below.

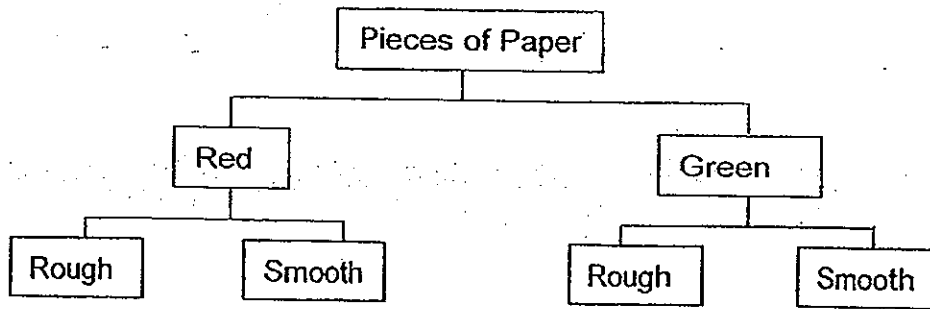

What are the properties that Sam used to classify the pieces of paper?

- (1) size and shape
- (2) texture and size
- (3) shape and colour
- (4) colour and texture

3. The diagram below shows a bird kept in a cage.



After three days, the bird died because it did not have \_\_\_\_\_.

- A. air
  - B. food
  - C. water
  - D. sunlight
- 
- (1) A and B
  - (2) A and D
  - (3) B and C
  - (4) C and D

The table below shows the characteristics of some things, W, X, Y and Z.

| Things | Moves from place to place | Needs air, water and food | Reproduces | Has legs |
|--------|---------------------------|---------------------------|------------|----------|
| W      |                           | ✓                         | ✓          |          |
| X      | ✓                         | ✓                         | ✓          | ✓        |
| Y      | ✓                         | ✓                         | ✓          |          |
| Z      | ✓                         |                           |            | ✓        |

Which of the following is most likely to be a non-living thing?

- (1) W
- (2) X
- (3) Y
- (4) Z

5. Five fruit flies are put into each of the four bottles (A, B, C and D) as shown below.

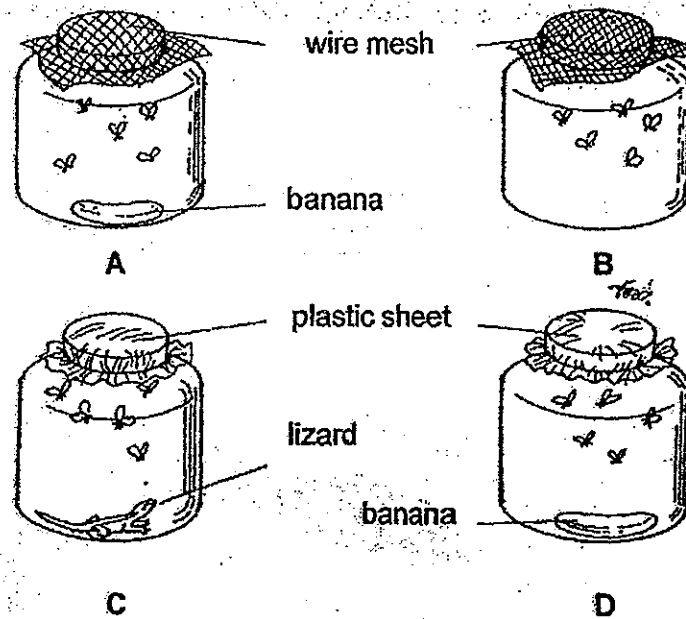

In which bottle will the fruit flies increase in number after a few weeks?

- (1) A
- (2) B
- (3) C
- (4) D

6. Andy, Ben and Cathy made a statement each.

Andy: The bird flies away when a dog runs towards it.

Ben: The mimosa plant closes its leaves slowly whenever I touch it.

Cathy: We should run to a shelter now, as it has started to rain!

What do the statements above show about living things?

- (1) They die.
- (2) They respond to changes around them.
- (3) They need air, water and food to survive.
- (4) They reproduce to ensure the survival of its own kind.

7. The chart below shows how fruits can be classified.

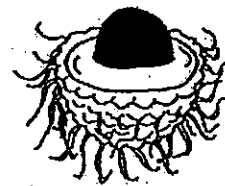
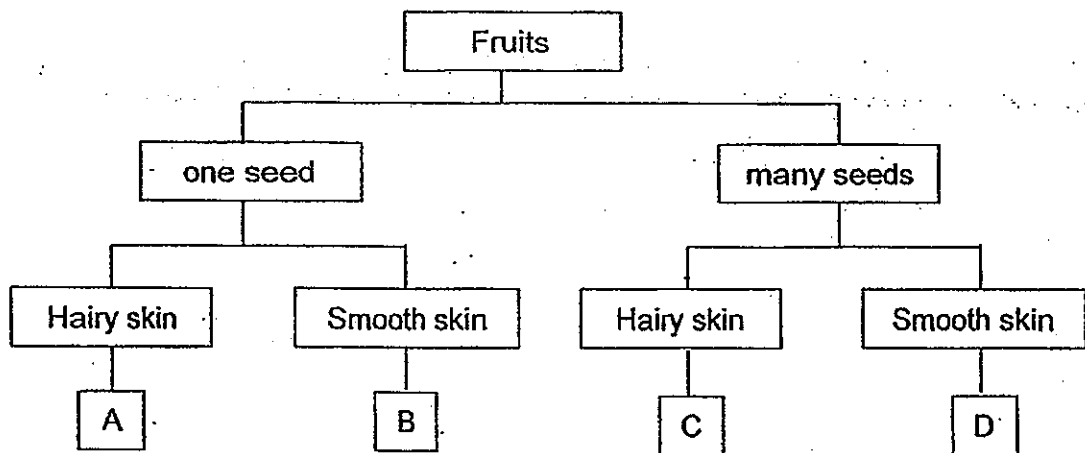

The fruits shown above can be represented by the letters \_\_\_\_\_.

- (1) A and C
- (2) A and D
- (3) B and C
- (4) B and D

Look at the diagram of the two leaves below.

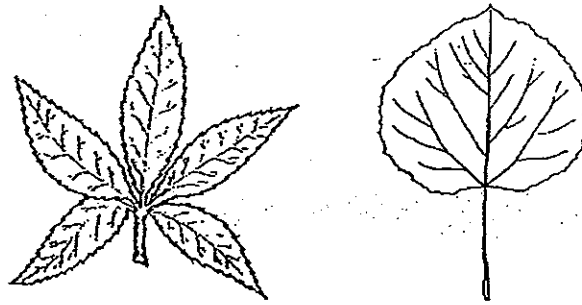

How are the leaves similar?

- (1) Both leaves have a toothed edge.
- (2) Both leaves have a smooth edge.
- (3) Both leaves are of the same size.
- (4) Both leaves are of the same shape.

9. The diagram below shows an animal.

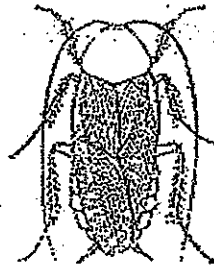

Based on this diagram, which of the following can you observe?

- A. It has six legs.
  - B. It lays eggs.
  - C. It lives in dark places.
  - D. It has a pair of long antennae.
- 
- (1) A and B only
  - (2) A and D only
  - (3) B, C and D only
  - (4) A, B, C and D

10. Study the diagram of the two birds below.

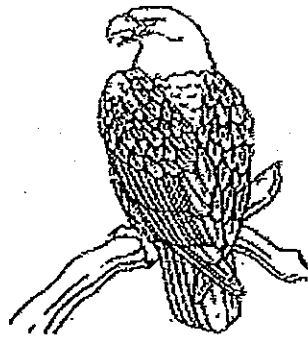

What are different between these two birds?

- A. The shape of their beaks.
- B. Their type of body covering.
- C. The way they reproduce.

- (1) A only
- (2) B only
- (3) A and B only
- (4) A and C only

11. John found an animal, as shown in the diagram below.

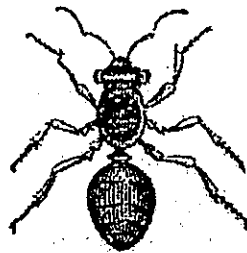

He observed the animal and recorded his findings below.

- A. It has six legs.
- B. It does not have wings.
- C. It has three body parts.

Which of the above statements will help him classify this animal under the group of insects?

- (1) A and B only
- (2) A and C only
- (3) B and C only
- (4) A, B and C

12. The diagram below shows some parts of the fish which are labelled A, B, C and D.

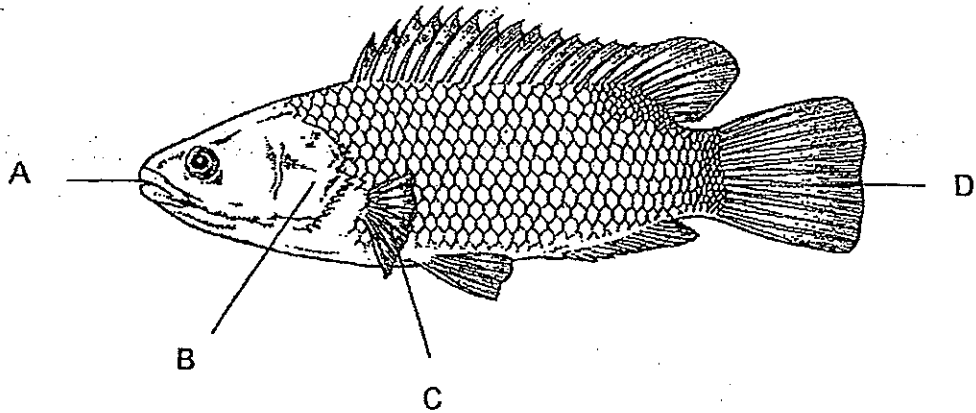

Which of the labelled parts help the fish to swim?

- (1) A and D only
  - (2) B and C only
  - (3) C and D only
  - (4) A, B and C only
13. The diagram below shows a type of fungi.



Which one of the following statements is incorrect about this type of fungi?

- (1) They make their own food.
- (2) They reproduce by spores.
- (3) They do not need light to grow.
- (4) They have a cap, a stalk and gills.



14. The picture below shows four slices of bread of the same loaf and of the same thickness.

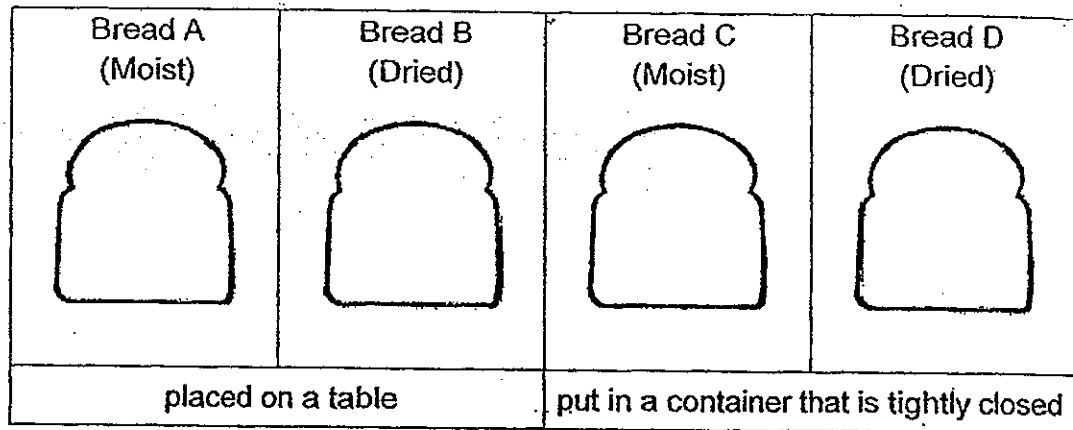

Which bread would have mould growing on it first?

- (1) Bread A
  - (2) Bread B
  - (3) Bread C
  - (4) Bread D
15. Jenny made the following statements about bacteria and fungi.

- A. All fungi are harmful.
- B. All bacteria need sunlight to make food.
- C. All bacteria are living things.
- D. All fungi need air, food and water to live.

Which of the statements above are correct?

- (1) A and B
- (2) A and D
- (3) B and C
- (4) C and D

**END OF BOOKLET A**

**GO ON TO BOOKLET B**



16. Beatrix was given some bags of beans as shown below.

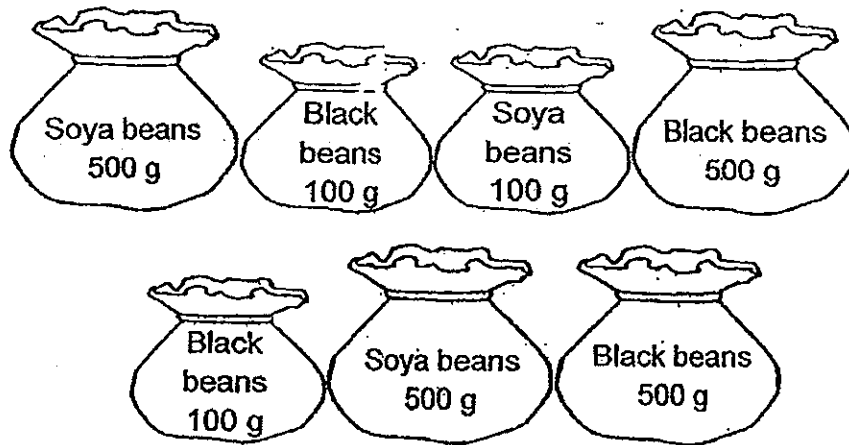

(a) Fill in each blank with the correct word.

She can put the bags of beans into groups based on their

\_\_\_\_\_ and their \_\_\_\_\_ [1]

(b) Complete the classification chart below to show how the bags of beans can be grouped. [2]

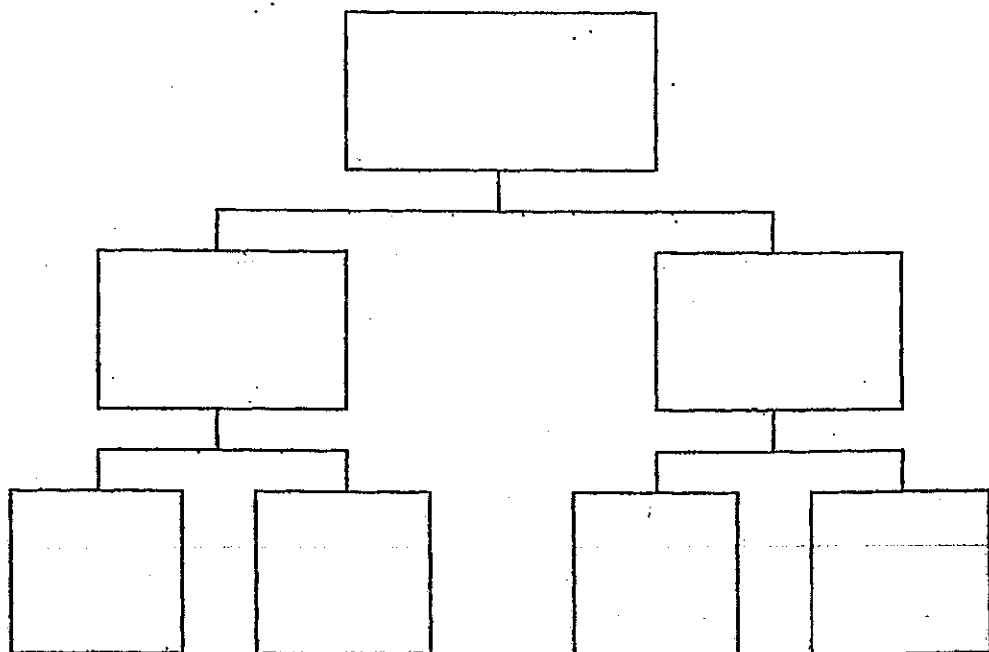

Marks :  / 3

17. Benjamin carries out an experiment on a plant near the window.

He places a cardboard box, with an opening on one side, over the plant and waters the plant daily. After one week, he observes the change in the plant as shown below.

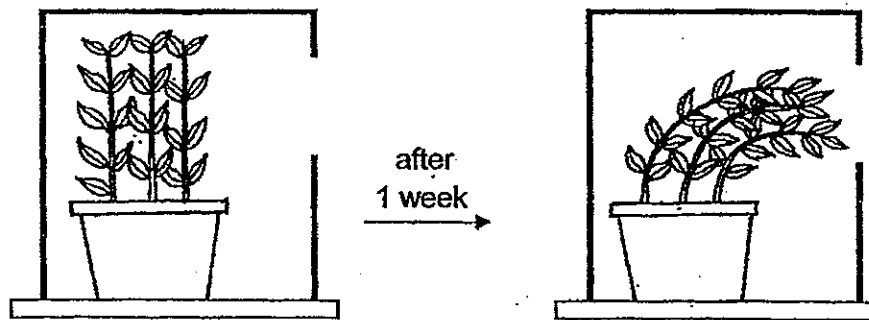

- (a) Benjamin observes that parts of the plant are growing towards the opening.

Besides movement and growth, what is another characteristic of living thing that this experiment shows? [1]

---

---

- (b) Besides water, name two other things that the plant needs in order to stay alive? [1]

---

---

- (c) Benjamin wants to make the plant grow upright again.

State one way he can make the plant do so. [1]

---

---

Marks : 

|     |
|-----|
| / 3 |
|-----|

18. The classification table below shows how some animals, P, Q, R and S, can be grouped.

| Animals              |             |                             |             |
|----------------------|-------------|-----------------------------|-------------|
| Feed young with milk |             | Do not feed young with milk |             |
| Can swim             | Cannot swim | Can swim                    | Cannot swim |
| P                    | Q           | R                           | S           |

- (a) State all the characteristics of Animal Q. [2]

---

---

- (b) From the table, in which main group of animals would animals P and Q be grouped under? [1]

---

- (c) From the table, state one similarity and one difference between Animals P and R. [2]

Similarity:

---

---

Difference:

---

---

---

Marks : 

|    |
|----|
| 15 |
|----|

19. The diagrams below show some animals.

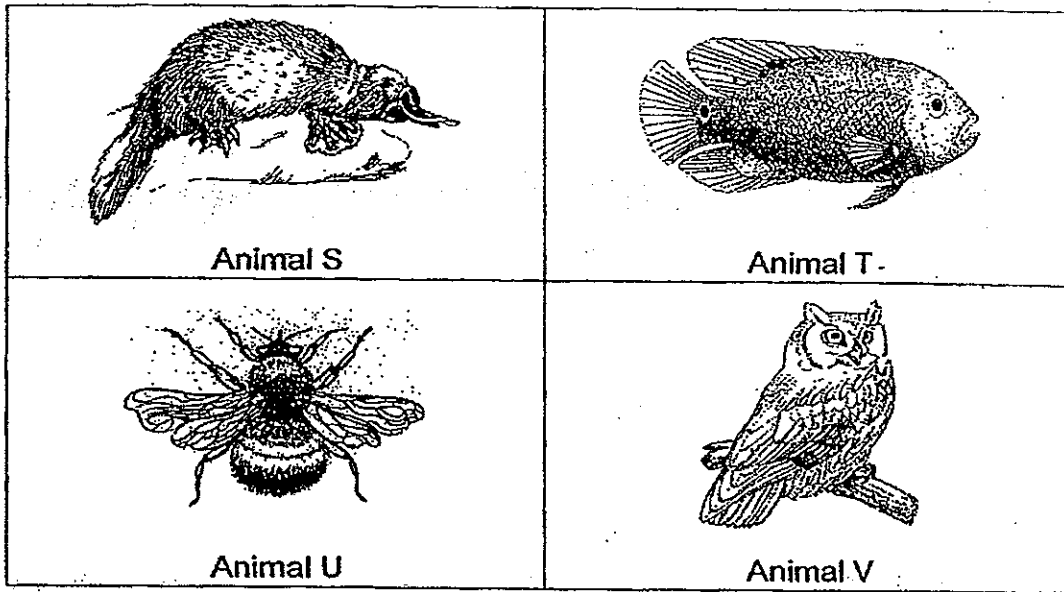

(a) Place these animals in their correct groups in the table below.

Write the letters S, T, U and V in the correct boxes.

[2]

| Main Groups of Animals | Animal |
|------------------------|--------|
| Birds                  |        |
| Fishes                 |        |
| Insects                |        |
| Mammals                |        |

Marks :

12

- (b) Based on your answer in (a), state one characteristic that you can **observe from the diagram** that each of the following animals has which is common to the animals in that particular group it belongs to. [4]

| Animal | Characteristic which can be observed and is common to the animals in the group it belongs to. |
|--------|---|
| S      |   |
| T      |   |
| U      |   |
| V      |   |

Marks : 

|     |
|-----|
| / 4 |
|-----|

- 20 (a) Jane needs to use a microscope to observe bacteria but she does not need to use a microscope to observe the bracket fungi.

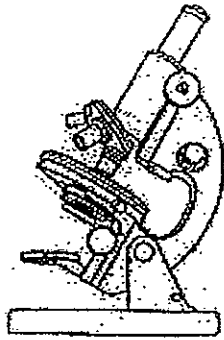

microscope

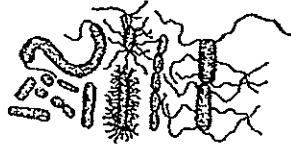

bacteria

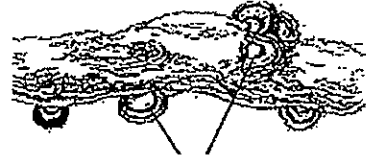

bracket fungi

Why does she need to use a microscope to observe the bacteria? [1]

---

---

- (b) The diagram below shows what Jane drew when she observed three bacteria under a microscope over a period of 10 minutes.

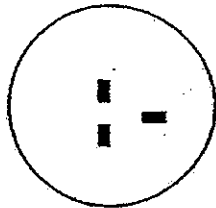

0 minute

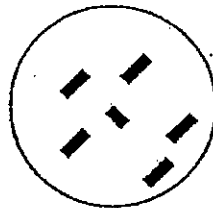

5 minutes

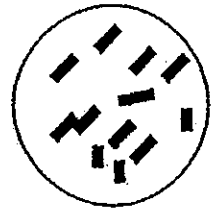

10 minutes

Based on Jane's observation, what characteristic of living things does this show? [1]

---

---

Marks :

12



- (c) Jane and Evan saw some bracket fungi on their way home from school. Jane told Evan that the bracket fungi are plants.

Is Jane correct? Explain your answer.

[1]

---

---

---

~ END OF PAPER ~

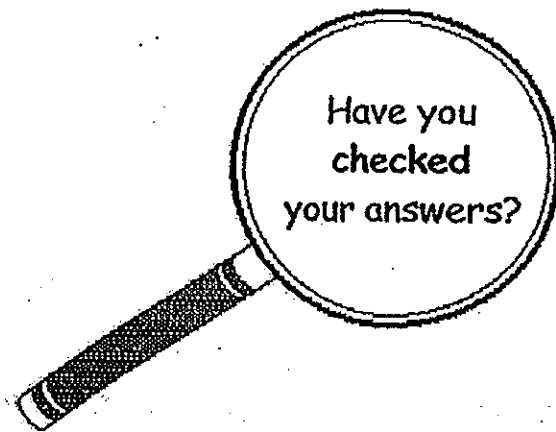

Marks :

1

# ANSWER SHEET

**EXAM PAPER 2013**

**SCHOOL : MAHA BOHDI SCHOOL**

**SUBJECT : PRIMARY 3 SCIENCE**

**TERM : SA1**

|    |    |    |    |    |    |    |    |    |     |     |     |     |     |     |
|----|----|----|----|----|----|----|----|----|-----|-----|-----|-----|-----|-----|
| Q1 | Q2 | Q3 | Q4 | Q5 | Q6 | Q7 | Q8 | Q9 | Q10 | Q11 | Q12 | Q13 | Q14 | Q15 |
| 3  | 4  | 3  | 4  | 1  | 2  | 2  | 1  | 2  | 1   | 2   | 3   | 1   | 1   | 4   |

Booklet B

Q16) a) weight and their type/kind of beans

b)

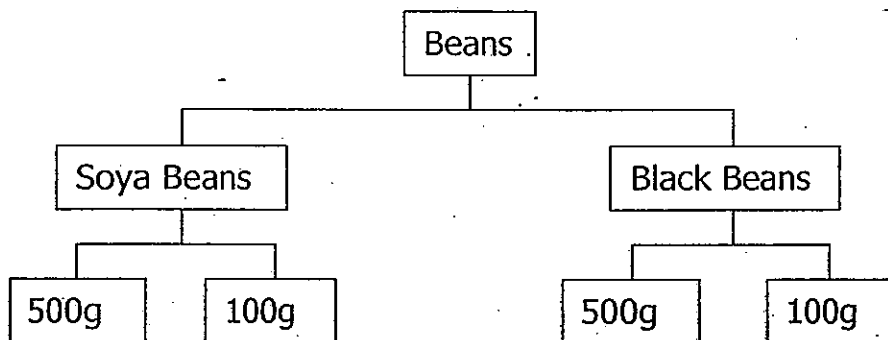

Q17) a) Living things respond to changes

b) The plant needs air and food in order to stay alive

c) Remove the box

Q18) a) Animal Q feeds its young with milk and cannot swim

b) Mammals

c) Similarity: They both can swim

Difference: Animal P feed its young with milk while Animal R does not feed its young with milk

Q19) a)

| Main Groups of Animals | Animal |
|------------------------|--------|
| Birds                  | V      |
| Fishes                 | T      |
| Insects                | U      |
| Mammals                | S      |

b)

| Animal | Characteristic which can be observed and is common to the animals in the group it belongs to |
|--------|--|
| S      | It has fur   |
| T      | It has scales / gills  |
| U      | It has six legs  |
| V      | It has a beak  |

Q20) a) Bacteria are micro-organisms

b) Living things reproduce

c) No, bracket fungi does not make its food

METHODIST GIRLS' SCHOOL  
Founded in 1887



MID-YEAR EXAMINATION 2013  
PRIMARY 3  
SCIENCE

BOOKLET A

Total Time for Booklets A and B: 1 hour 45 minutes

INSTRUCTIONS TO CANDIDATES

Do not turn over this page until you are told to do so.

Follow all instructions carefully.

Answer all questions.

Shade your answers in the Optical Answer Sheet (OAS) provided.

Name: \_\_\_\_\_ ( )

Class: Primary 3. \_\_\_\_\_

Date: 16 May 2013

This booklet consists of 15 printed pages including this page.

For each question from 1 to 30; four options are given. One of them is the correct answer. Make your choice and shade the oval (1, 2, 3 or 4) on the Optical Answer Sheet.

(60 marks)

- 1 The table below shows the characteristics of 3 things, P, Q and R

| Thing | Will grow | Respond to changes | Will move |
|-------|-----------|--------------------|-----------|
| P     | √         | X                  | X         |
| Q     | √         | √                  | √         |
| R     | X         | √                  | √         |

Which of the above could be a living thing?

- (1) P only
  - (2) Q only
  - (3) P and R only
  - (4) Q and R only
- 2 Mary observed her kitten for one hour. Which of her observations does not show that her kitten is a living thing?
- (1) It drinks water.
  - (2) It has four legs.
  - (3) It purrs when cuddled.
  - (4) It runs and hides under a chair when it heard a loud thunder.

(Go on to the next page)

3 Jane saw a lizard on the table. She threw a book at it and observed that the lizard dropped its tail immediately. What does this show about living things?

- (1) Living things die.
- (2) Living things grow.
- (3) Living things reproduce.
- (4) Living things respond to changes.

4 Study the table below carefully.

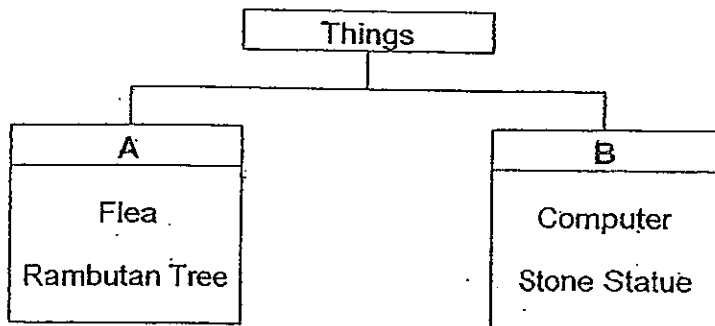

Which of the following headings best represent headings A and B?

|     | A                                   | B                                      |
|-----|-------------------------------------|--|
| (1) | Can produce sounds                  | Cannot produce sounds                  |
| (2) | Can respond to changes              | Cannot respond to changes              |
| (3) | Can make their own food             | Cannot make their own food             |
| (4) | Can move freely from place to place | Cannot move freely from place to place |

(Go on to the next page)

5 Why do animals move from place to place?

D: To escape from dangers.

E: To become food for others.

F: To look for food, water and shelter.

(1) D and E only

(2) D and F only

(3) E and F only

(4) D, E and F

6 The diagram below shows how plants can be classified.

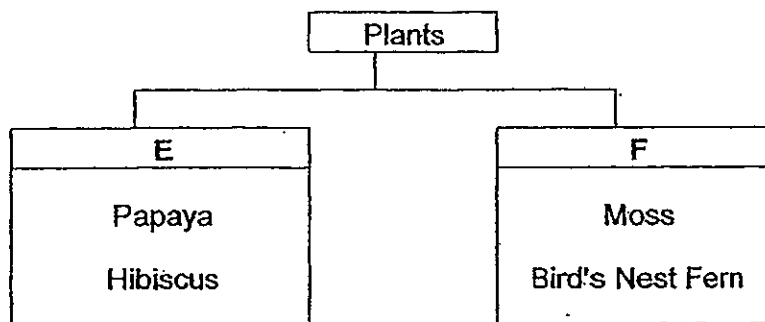

Which one of the following is the most suitable heading for E and F?

|     | E                    | F                     |
|-----|----------------------|-----------------------|
| (1) | Non-poisonous        | Poisonous             |
| (2) | Bears flowers        | Does not bear flowers |
| (3) | Can make food        | Cannot make food      |
| (4) | Reproduces by spores | Reproduces by seeds   |

(Go on to the next page)

7 Mrs Tan has some flowering plants in her garden. She is able to tell that they are flowering plants because the plants have \_\_\_\_\_.

- (1) fruits
- (2) woody stems
- (3) spores on their leaves
- (4) the leaves have different shapes and edges

8 The picture shown below is a cactus plant that can be found in a desert.



Which of the following statement(s) is/ are true about the cactus?

- A: It is a type of fern.
- B: It can make its own food.
- C: It does not need water to stay alive.

- (1) B only
- (2) C only
- (3) A and B only
- (4) A and C only

(Go on to the next page)



- 9 Below are two green plants, X and Y, found growing in a garden.

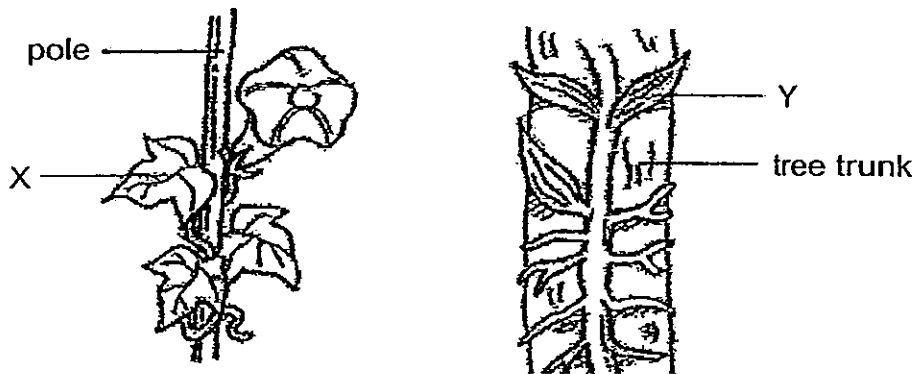

Which one of the following statements about plants, X and Y, is correct?

- (1) Both X and Y cannot use their leaves make their own food.
  - (2) Both X and Y uses their stems to climb up supports to get sunlight.
  - (3) X uses its flowers while Y uses its leaves to make food.
  - (4) X uses its stem while Y uses its roots to climb up supports.
- 10 Three girls made the following statements about the roots of plants:

Anne : Some roots can be eaten.

Belle : All roots grow underground.

Cindy : Some roots grow above the ground and some roots grow underground

Whose statement(s) is/are correct?

- (1) Anne only
- (2) Belle only
- (3) Anne and Cindy only
- (4) Belle and Cindy only

(Go on to the next page)

- 11 Amy kept an equal number of caterpillars in each of the 4 containers. The conditions in each container are shown below.

| Container | Has air? | Has food? | Has water? | Has sunlight? |
|-----------|----------|-----------|------------|---------------|
| W         | Yes      | Yes       | Yes        | No            |
| X         | Yes      | No        | Yes        | Yes           |
| Y         | Yes      | Yes       | No         | Yes           |
| Z         | No       | Yes       | Yes        | Yes           |

After 1 week, the caterpillars in 3 of the containers were all dead. In which container are the caterpillars most likely to survive?

- (1) Container W
  - (2) Container X
  - (3) Container Y
  - (4) Container Z
- 12 Which of the following characteristics describe the duck-billed platypus as a mammal?
- A: It has hair.
  - B: It lays eggs.
  - C: It lives on land.
  - D: It feeds its young with milk.
- (1) A and B only
  - (2) C and D only
  - (3) A and D only
  - (4) B and C only

(Go on to the next page)

- 13 Look at the classification diagram shown below:

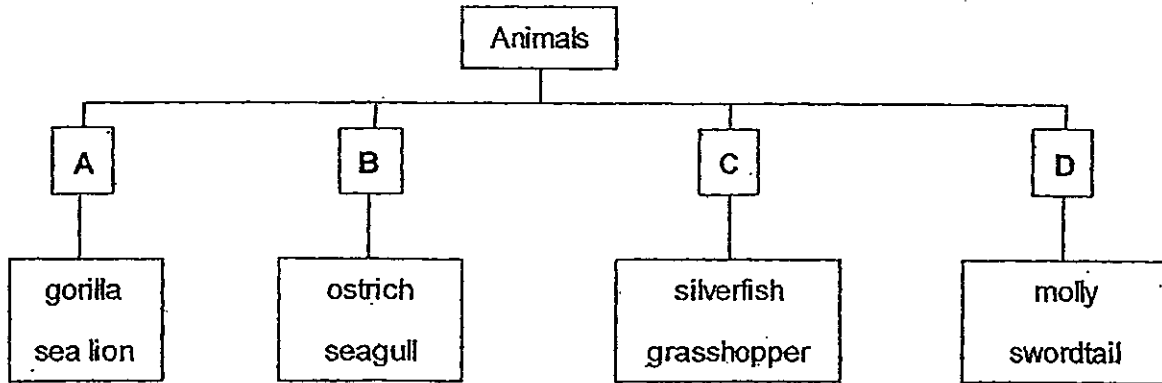

In which group will you place a spiny anteater?

- (1) A
  - (2) B
  - (3) C
  - (4) D
- 14 Which of the following is not true of all mammals?

M: They live on land

N: They suckle their young

O: They have hairs on their bodies

P: They give birth to their young alive

- (1) M only
- (2) M and N only
- (3) N and O only
- (4) M and P only

(Go on to the next page)

- 15 Sally recorded her observations of two animals, Animal S and Animal T, in the table below:

| Observations       | Animal S | Animal T |
|--------------------|----------|----------|
| Breathe with gills | Yes      | No       |
| Has 2 antennae     | No       | Yes      |
| Has 3 body parts   | No       | Yes      |

What could Animal S and Animal T be?

|     | Animal S   | Animal T  |
|-----|------------|-----------|
| (1) | Shark      | Bee       |
| (2) | Clownfish  | Spider    |
| (3) | Pelican    | Housefly  |
| (4) | Kingfisher | Dragonfly |

- 16 Which of the following objects are placed in the correct heading?

|     | Living things | Non-living things |               |
|-----|---------------|-------------------|---------------|
|     |               | Never alive       | Once alive    |
| (1) | Mushroom      | Wooden table      | Silk scarf    |
| (2) | Silk scarf    | Mushroom          | Aluminium pot |
| (3) | Aluminium pot | Silk scarf        | Mushroom      |
| (4) | Mushroom      | Aluminium pot     | Silk scarf    |

(Go on to the next page)

- 17 Study the flow chart carefully and identify A, B, C and D correctly.

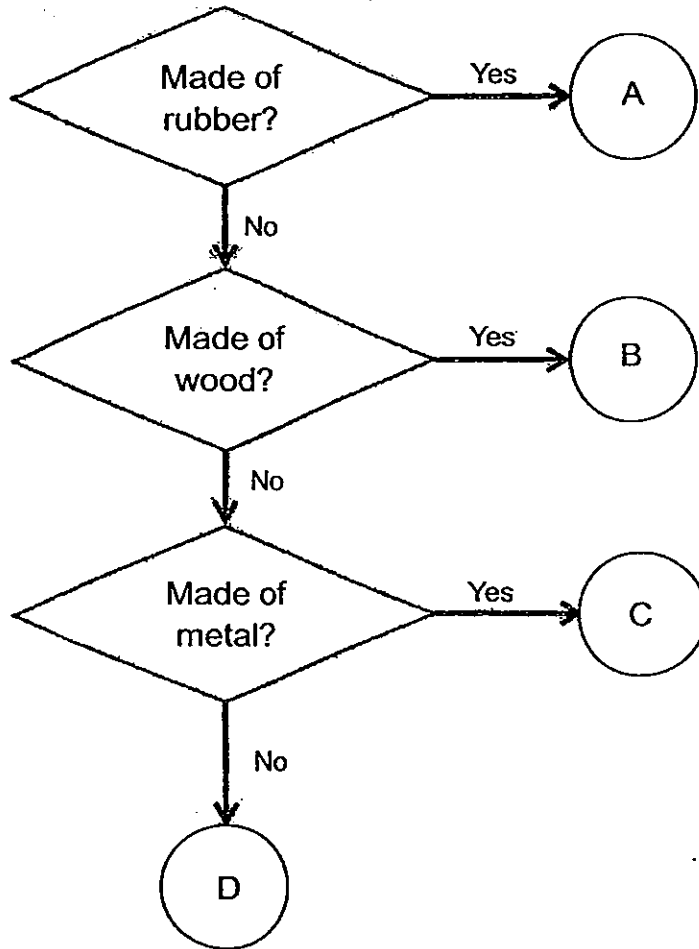

|     | A         | B         | C         | D         |
|-----|-----------|-----------|-----------|-----------|
| (1) | Nail      | Eraser    | Tyre      | Toothpick |
| (2) | Toothpick | Nail      | Eraser    | Tyre      |
| (3) | Tyre      | Toothpick | Nail      | Blouse    |
| (4) | Eraser    | Tyre      | Toothpick | Nail      |

(Go on to the next page)

- 18 Marie found two objects. She did some tests and she recorded her observations in the checklist below.

|                      | S | T |
|----------------------|---|---|
| Waterproof           | ✓ | × |
| Soft                 | ✓ | ✓ |
| Does not tear easily | ✓ | ✓ |
| Absorbent            | × | ✓ |

Which of the following correctly shows what S and T are made of?

|     | S        | T        |
|-----|----------|----------|
| (1) | T-shirt  | Raincoat |
| (2) | T-shirt  | Sponge   |
| (3) | Sponge   | T-shirt  |
| (4) | Raincoat | T-shirt  |

- 19 Which of the following is grouped correctly?

|     | Animal    | Plant | Fungi    | Micro-organism |
|-----|-----------|-------|----------|----------------|
| (1) | Earthworm | Fern  | Bacteria | Mould          |
| (2) | Earthworm | Mould | Fern     | Bacteria       |
| (3) | Earthworm | Fern  | Mould    | Bacteria       |
| (4) | Bacteria  | Fern  | Mould    | Earthworm      |

(Go on to the next page)

- 20 Sue tried to classify some objects into two groups as shown below. Why did she place the leather jacket and woollen socks in **Group S**?

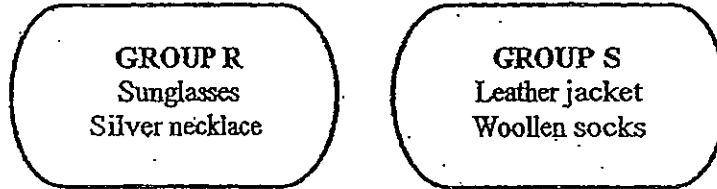

- A: They are flexible.  
B: They are waterproof.  
C: They are mainly made from animals.  
D: They are made from plants and animals:

- (1) A and B only  
(2) A and C only  
(3) A and D only  
(4) A, B and C only

21. David did an experiment with the eraser and the pencil as shown below. He used a pencil to poke holes in an eraser.



What can you conclude about the objects in David's experiment?

- (1) The pencil is lighter than the eraser.
  - (2) The pencil is harder than the eraser.
  - (3) The pencil is heavier than the eraser.
  - (4) The eraser is more flexible than the pencil.
22. Which of the statement(s) is/are true about fungi?
- A All fungi are micro-organisms.
  - B Fungi cannot make their own food.
  - C Fungi need air, food and water to survive.
  - D All fungi are harmful as they cause diseases to plants and animals.
- (1) B and C only
  - (2) C and D only
  - (3) A, B and C only
  - (4) A, C and D only

(Go on to the next page)



Study the diagram carefully and answer questions 23, 24 and 25.

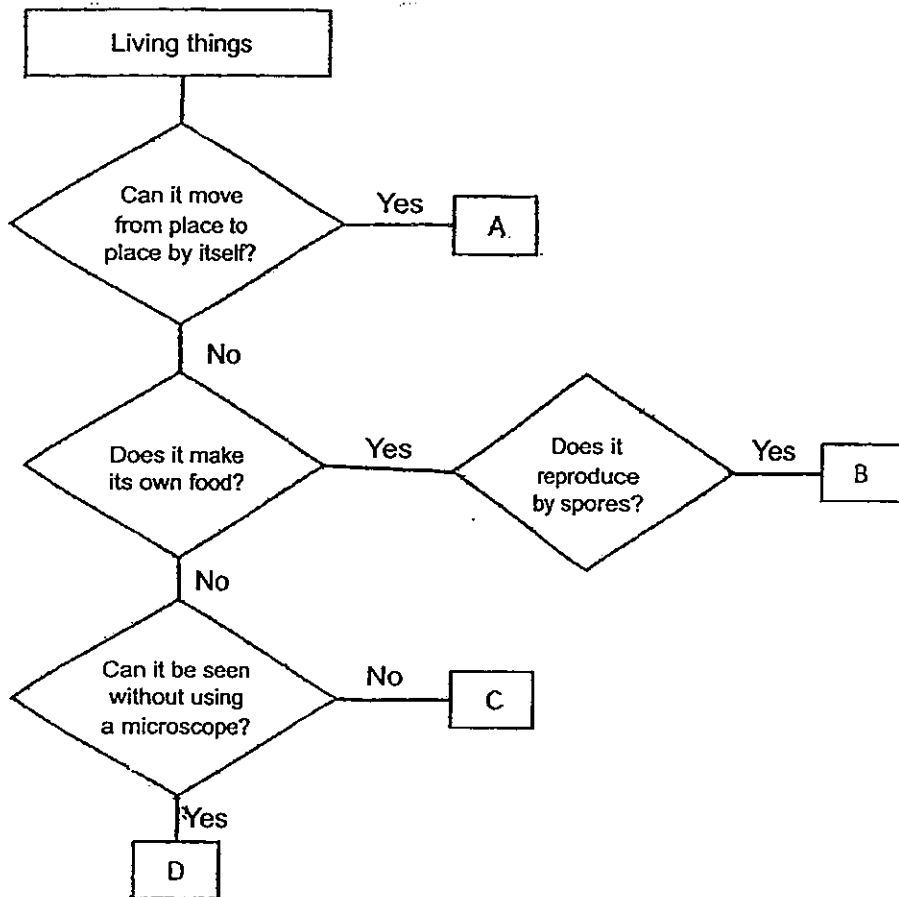

23 Which of the following represents non-flowering plants?

- (1) A
- (2) B
- (3) C
- (4) D

(Go on to the next page)

24 Which of the following represents the organism found in yogurt?

- (1) A
- (2) B
- (3) C
- (4) D

25 Which of the following letters represents the mushroom?

- (1) A
- (2) B
- (3) C
- (4) D

METHODIST GIRLS' SCHOOL  
Founded in 1887



MID-YEAR EXAMINATION 2013  
PRIMARY 3  
SCIENCE

BOOKLET B

Total Time for Booklets A and B: 1 hour 45 minutes.

INSTRUCTIONS TO CANDIDATES

Do not turn over this page until you are told to do so.

Follow all instructions carefully.

Answer all questions.

Write your answers in this booklet.

Name: \_\_\_\_\_ ( )

Class: Primary 3. \_\_\_\_\_

Date: 16 May 2013

|                  |             |
|------------------|-------------|
| <b>Booklet A</b> | <b>/ 50</b> |
| <b>Booklet B</b> | <b>/ 40</b> |
| <b>TOTAL</b>     | <b>/ 90</b> |

This booklet consists of 12 printed pages including this page

For questions 26 to 37, write your answers in the space provided.

(40 marks)

- 26 Betty placed 150 g of food and 150 ml of water in three containers E, F and G. She recorded the amount of food and water left at the end of the week:

| Container | Amount of food (g) | Amount of water (ml) |
|-----------|--------------------|----------------------|
| E         | 150                | 150                  |
| F         | 58                 | 38                   |
| G         | 53                 | 42                   |

- (a) Based on the above information, which container(s) contain(s) living things? (1m)
- \_\_\_\_\_
- (b) What does this experiment tell you about living things? (1m)
- \_\_\_\_\_
- \_\_\_\_\_
- (c) If Betty continues the experiment for another 3 days, what will be the final amount of food and water left in Container E if the rate of evaporation of water is not considered in this experiment? (1m)
- \_\_\_\_\_
- \_\_\_\_\_

(Go on to the next page)

- 27 Ben has a pet dog, Lucky and a robotic dog, Robo. He says that Lucky is a living thing but Robo is a non-living thing.

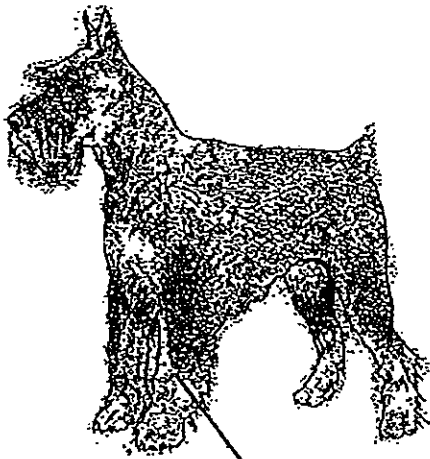

Lucky

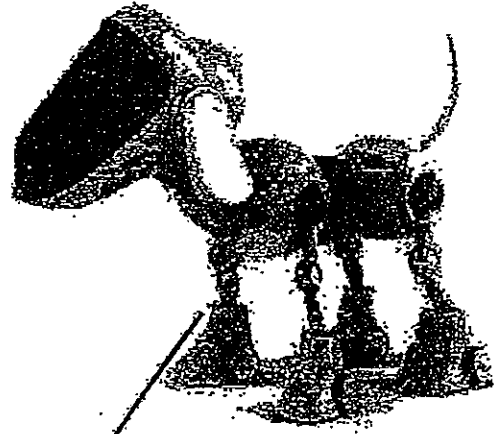

Robo

- (a) How did he make this conclusion? List two characteristics of living things that Lucky has but Robo does not have. (2m)

(i) \_\_\_\_\_

(ii) \_\_\_\_\_

- (b) Robo displays some characteristics of living things. Name one of the characteristics. (1m)

\_\_\_\_\_  
\_\_\_\_\_

(Go on to the next page)

28 Refer to the pictures of the two fruits shown below:

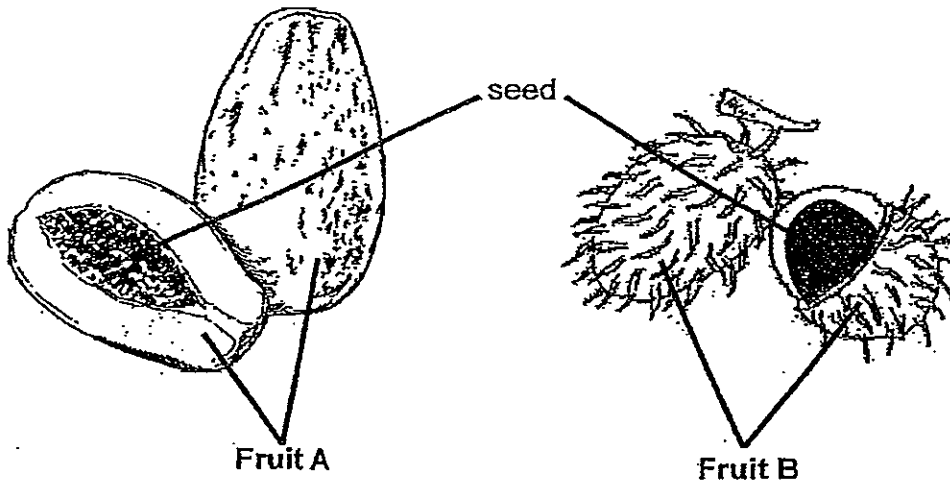

- (a) Based only on your observation of the fruits in the picture shown above, write down one similarity and one difference between the two fruits. (Do not compare shapes, size or colours). (2m)

Similarity: \_\_\_\_\_

\_\_\_\_\_

Difference: \_\_\_\_\_

\_\_\_\_\_

- (b) What do you think the seed is used for? (1m)

\_\_\_\_\_

\_\_\_\_\_

(Go on to the next page)

30 Look at the animals shown below. They are not drawn to scale.

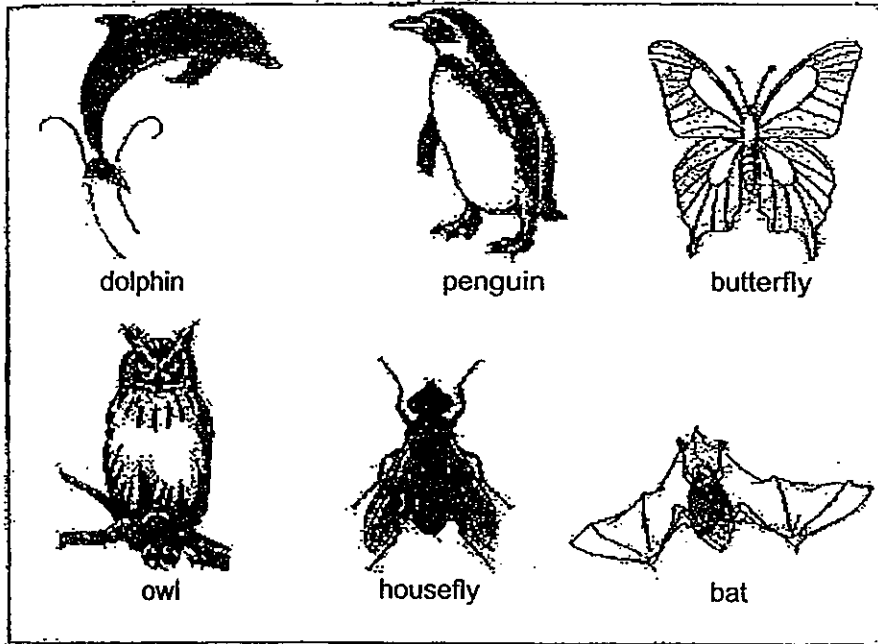

Complete the classification table shown below:

- (a) Put in appropriate headings for X and Y. (1m)
- (b) Classify the animals shown above under the 3 headings. (3m)

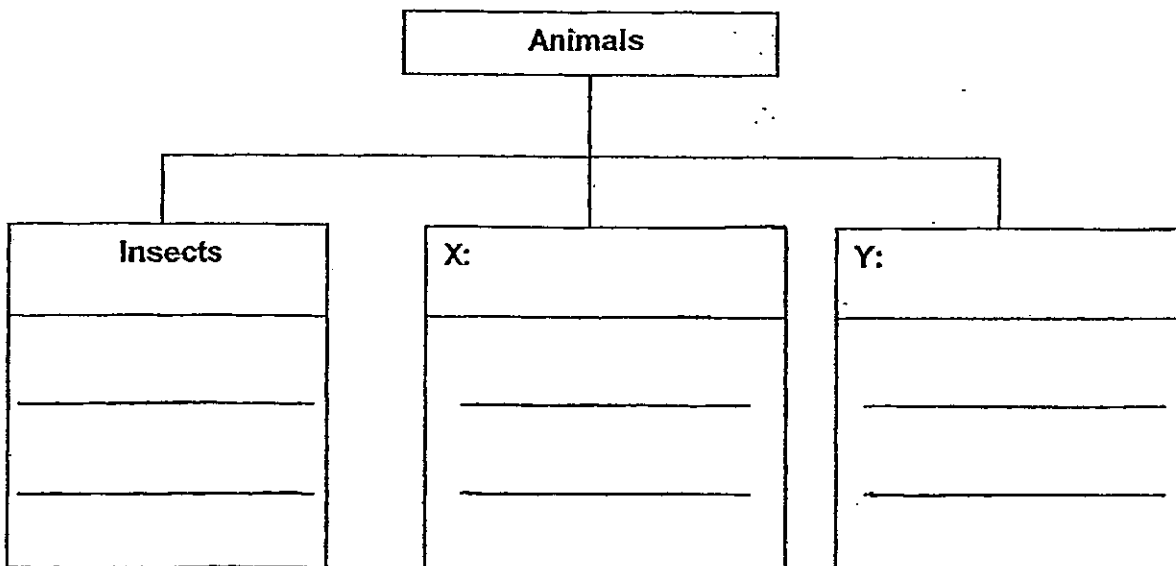

(Go on to the next page)

29 Study the classification chart shown below:

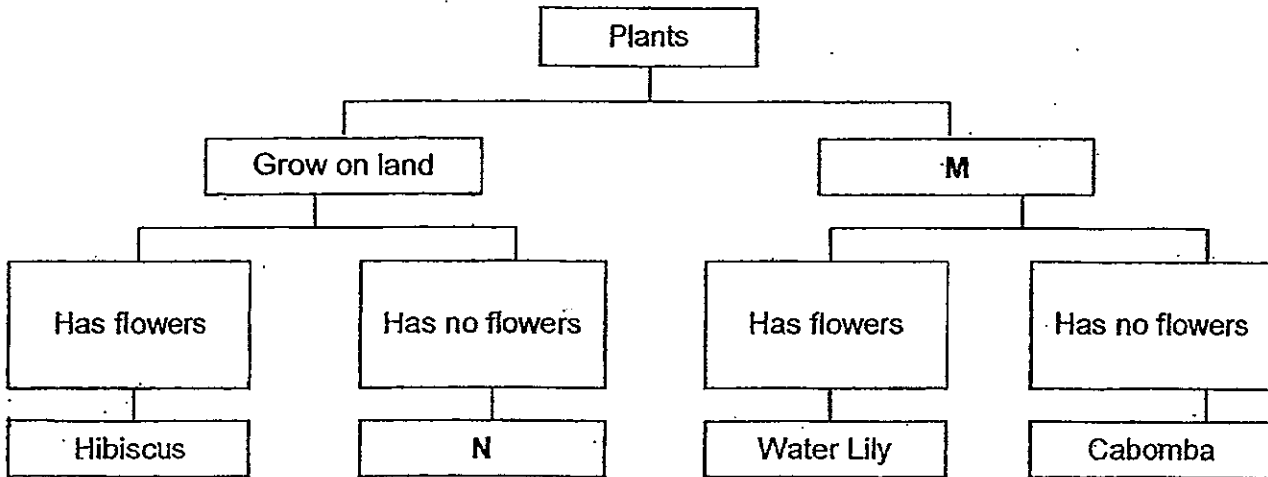

(a) Suggest a suitable heading for **M**. (1m)

---

(b) Based on the classification chart above, describe **N**. (1m)

---

(c) What could **N** possibly be? Give one possibility. (1m)

---

(Go on to the next page)



31 Below is a flowchart showing the characteristics of some animals:

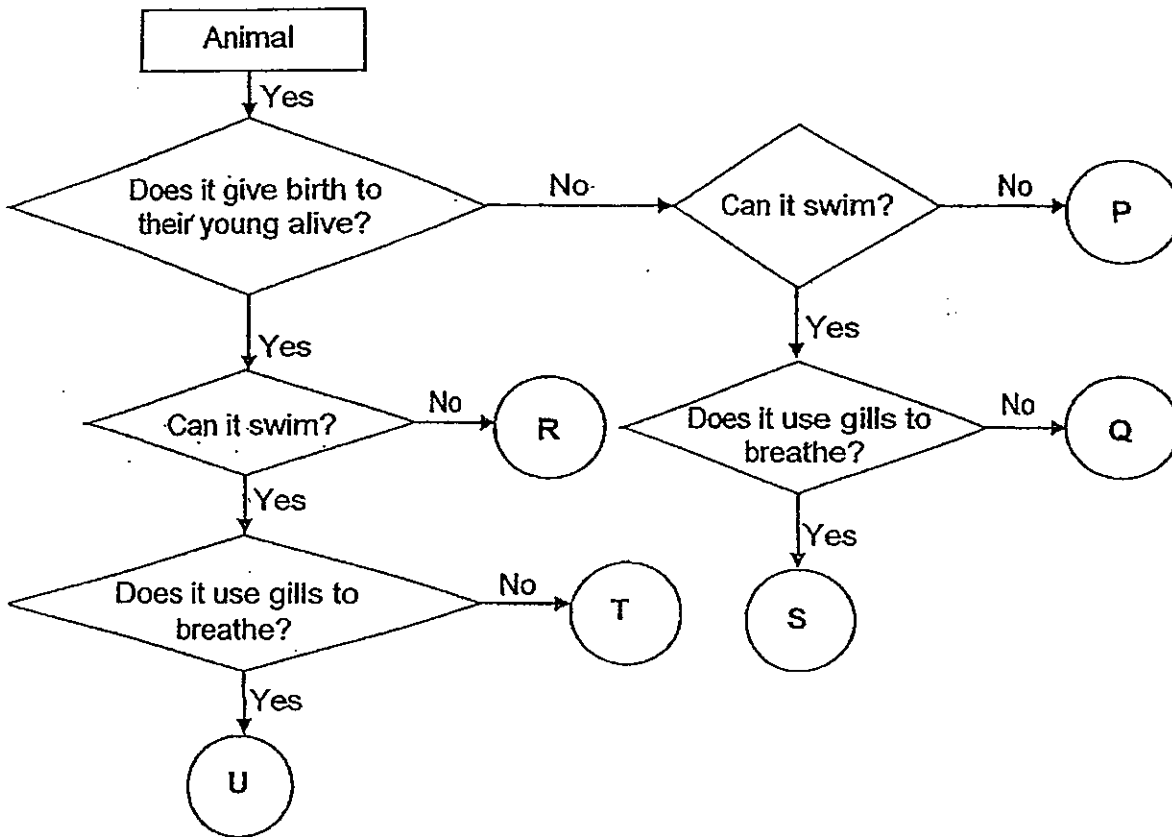

- (a) From the flowchart, state two similarities between Animal U and Animal S. (1m)
- \_\_\_\_\_
- \_\_\_\_\_
- (b) From the flowchart, state one difference between Animal T and Animal Q. (1m)
- \_\_\_\_\_
- (c) Give one example of Animal R and one example of Animal U. (2m)
- \_\_\_\_\_

(Go on to the next page)

- 32 Chloe opened a packet of cookies and she found a packet of desiccant (drying agent) among the cookies. The desiccant is shown in the picture below.

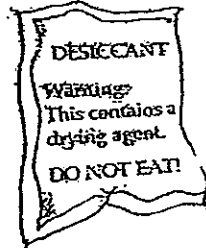

How can the packet of drying agent prevent the cookies from going bad?

(2m)

---



---

- 33 Study the list of objects below.

|                |                   |
|----------------|-------------------|
| Aluminium foil | Brick             |
| Spectacle lens | Tracing paper     |
| Frosted glass  | Plastic food wrap |

Classify the objects into the table below.

| Transparent | Translucent | Opaque |
|-------------|-------------|--------|
|             |             |        |

(Go on to the next page)

34 Mrs Li prepared a sandwich for Raine to bring to school. However, Raine had forgotten to eat the sandwich at recess and it was left in her bag. A few days later, Mrs Li took out the sandwich from Raine's bag and it had a foul smell.

- (a) Draw in the diagram below what Mrs Li would see on the sandwich after a few days. (1m)

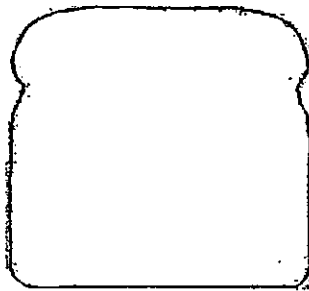

- (b) What is the organism that you drew in (a) called? (1m)
- 

(Go on to the next page)

35 Study the pictures below carefully.

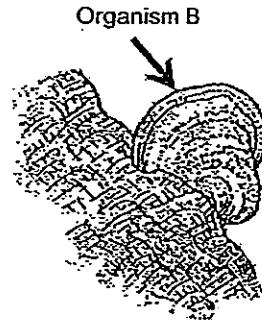
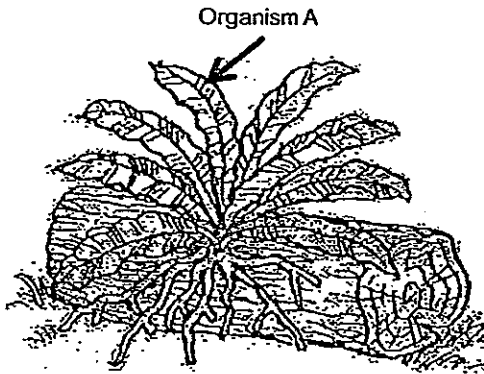

(a) Identify the organisms shown.

Organism A - \_\_\_\_\_ (1m)

Organism B - \_\_\_\_\_ (1m)

(b) State one similarity between the two organisms. (1m)

\_\_\_\_\_

(c) State one difference between the two organisms. (1m)

\_\_\_\_\_

\_\_\_\_\_

(Go on to the next page)

- 36 Tasha set up an experiment as shown below.

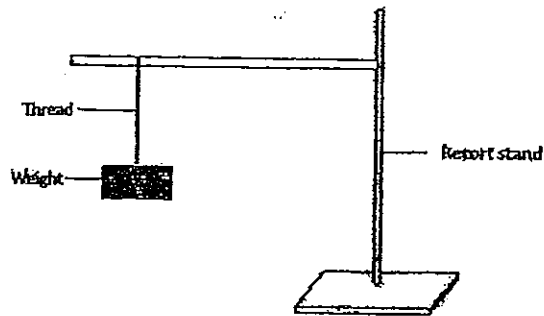

She increased the number of weights to the thread just before it broke.

- (a) What property of the thread was Tasha trying to find out? (1m)

---

- (b) Tasha decided to test the threads of different materials that are of similar length and thickness. Afterwards, she also tested if the threads were also waterproof. Her observations were recorded in the table below.

|   | Thread P | Thread Q | Thread R | Thread S |
|---|----------|----------|----------|----------|
| Number of weights before the thread broke | 11       | 27       | 25       | 5        |
| Waterproof                                | Yes      | No       | Yes      | No       |

From the observations, which thread would you use as a fishing line?

(1m)

---

- (c) Explain your answer for part (b). (2m)

---



---

(Go on to the next page)

37 Marlin had the following clothing in his cupboard.



Singlet



Raincoat

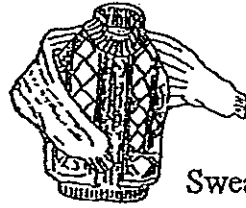

Sweater

(a) Complete the table below with the material used to make each clothing.

Do not use fabric as your answer and no answer should be repeated.

(2m)

| Top      | Singlet | Raincoat | Sweater |
|----------|---------|----------|---------|
| Material |         |          |         |

(b) Which of the object (s) shown does not come from plants? (1m)

---

(c) Give two reasons to explain why the singlet is suitable to wear on a hot and sunny day? (2m)

---



---



Methodist Girls' School Mid-Year Examination 2013 P3 Science

Booklet A

|    |    |    |    |    |    |    |    |    |    |    |    |    |    |    |
|----|----|----|----|----|----|----|----|----|----|----|----|----|----|----|
| 1  | 2  | 3  | 4  | 5  | 6  | 7  | 8  | 9  | 10 | 11 | 12 | 13 | 14 | 15 |
| 2  | 2  | 4  | 2  | 2  | 2  | 1  | 1  | 4  | 3  | 1  | 3  | 1  | 4  | 1  |
| 16 | 17 | 18 | 19 | 20 | 21 | 22 | 23 | 24 | 25 |    |    |    |    |    |
| 4  | 3  | 4  | 3  | 2  | 2  | 1  | 2  | 3  | 4  |    |    |    |    |    |

Booklet B

- 26 a F and G  
 b Living things need food and water to survive.  
 c The amount of food and water would remained unchanged.
- 27 a (i) Lucky has fur while robo is made up of man-made material.  
 (ii) Lucky need food and water to survive while robo does not need food and water.  
 (Or Lucky need to breathe and take in oxygen while robo does not breathe.)  
 b Robo is able to move on its own, like living things, when powered.
- 28 a Similarity: Both Fruit A and B contain one seed.  
 Difference: Fruit A has a smooth outer covering while Fruit B has hair-like hooks on its outer covering.  
 b The seed is used to reproduce into young plants by the parent plant.
- 29 a Grow in water b N grows on land and has no flowers.  
 c Fern / mosses (accept any one)

- 30 a Birds / Mammals  
 b

|           |         |         |
|-----------|---------|---------|
| Insects   | Mammals | Birds   |
| Housefly  | Bat     | Penguin |
| Butterfly | Dolphin | Owl     |

(Note: the animals must be arranged correctly under each of the above headings.)

- 31 a Both animal U and S can swim.  
 b T gives birth to young alive while Q does not give birth to its young alive.  
 c R: rabbits U: guppy (accept any reasonable answers for R and U)
- 32 Desiccant removes the moisture found in the sealed packet of cookies hence preventing the growth of living things like bacteria and moulds that required moisture to survive and grow, to make the cookies go bad.

33

|                                     |                                |                         |
|-------------------------------------|--------------------------------|-------------------------|
| Transparent                         | Translucent                    | Opaque                  |
| Spectacle lens<br>Plastic food wrap | Frosted glass<br>Tracing paper | Aluminium foil<br>Brick |



- 34 a  b Mould (mold)
- 35 a Organism A – Fern Organism B – Fungus  
 b Both organisms reproduce by spores.  
 c Organism A contains chlorophyll and can make its own food via photosynthesis while organism B does not contain chlorophyll and cannot make its own food.

- 36 a Strength of the thread. b Thread R  
 c Thread R is the strongest waterproof thread that can be used as a fishing line.

37

|          |         |          |         |
|----------|---------|----------|---------|
| Top      | Singlet | Raincoat | Sweater |
| Material | Cotton  | Plastic  | Wool    |

- b Raincoat c The singlet is made of a thin material and does not trap excessive heat.





**NANYANG PRIMARY SCHOOL**

**PRIMARY THREE SCIENCE**

**SEMESTRAL ASSESSMENT 1  
2013**

**BOOKLET A**

**Date : 14 May 2013**

**Duration : 1 h 45 min**

**Name : \_\_\_\_\_ (     )**

**Class: Primary 3 (     )**

**DO NOT OPEN THIS BOOKLET UNTIL YOU ARE TOLD TO DO SO.  
FOLLOW ALL INSTRUCTIONS CAREFULLY.**

**Booklet A consists of 16 printed pages including this cover page.**

**Section A (30 x 2 marks = 60 marks)**

For each question from 1 to 30, four options are given. One of them is the correct answer. Make your choice (1, 2, 3 or 4). Shade the correct oval (1, 2, 3 or 4) on the Optical Answer Sheet provided.

1. Study the classification chart below.

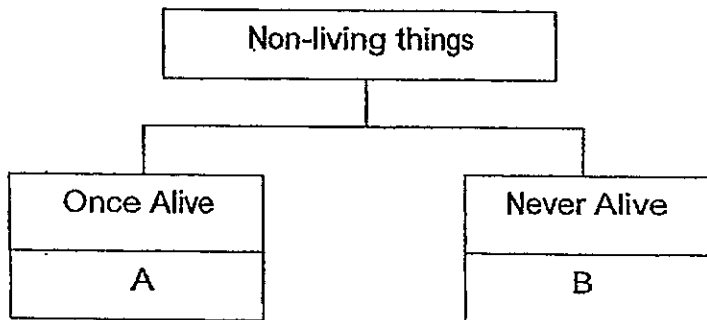

Which one of the following best represents objects A and B?

|     | A             | B            |
|-----|---------------|--------------|
| (1) | eraser        | cotton socks |
| (2) | potato chips  | toilet paper |
| (3) | plastic ruler | metal fork   |
| (4) | silk scarf    | diamond ring |

2. Which one of the following statements shows that living things respond to changes in the surrounding?

- A A boy put on a jacket in a cold cinema.
- B An alarm clock was set to ring at 7 a.m.
- C The leaves of the rain tree close in the evening.
- D A dog picked up a toy which was thrown to him.

- (1) A, B and C only
- (2) A, B and D only
- (3) A, C and D only
- (4) B, C and D only

3. Study the table below carefully. A tick (✓) indicates that a characteristic is observed.

| Objects | Characteristics |                                     |               |
|---------|-----------------|-------------------------------------|---------------|
|         | Can grow        | Can move freely from place to place | Can reproduce |
| P       | ✓               |                                     | ✓             |
| Q       |                 |                                     |               |

Based on the information in the table, which one of the following best represent objects 'P' and 'Q'?

|     | P        | Q     |
|-----|----------|-------|
| (1) | bacteria | moss  |
| (2) | monkey   | mould |
| (3) | fern     | ball  |
| (4) | fire     | car   |

4. In what ways are the three organisms shown in the box below **similar**?

|  |
|--|
| Mimosa<br>Allamanda<br>Dragon's scale fern |
|--|

- A They are poisonous.  
B They reproduce from seeds.  
C They need sunlight to make food.
- (1) A only                                      (2) C only  
(3) B and C only                             (4) A, B and C only

5. Andrea observed the following four animals.

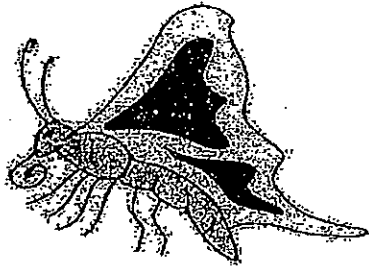

W

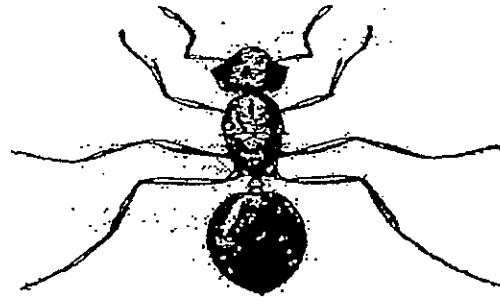

X



Y

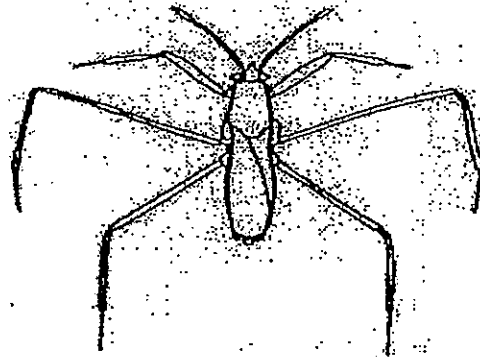

Z

She classified the animals into two groups as shown in the table below.

| Group A     | Group B |
|-------------|---------|
| W<br>X<br>Z | Y       |

Which of the following best represent headings for groups A and B?

|     | A                | B                   |
|-----|------------------|---------------------|
| (1) | Has 6 legs       | Has 8 legs          |
| (2) | Has wings        | Does not have wings |
| (3) | 2 pairs of wings | 1 pair of wings     |
| (4) | No feelers       | Has feelers         |

6. Charlene observed the characteristics of 3 different types of organisms, A, B and C. She then recorded her observations as shown in the table below. A tick (✓) indicates that the organism has a particular characteristic.

| Characteristic            | Organisms |   |   |
|---------------------------|-----------|---|---|
|                           | A         | B | C |
| It has flowers.           |           | ✓ |   |
| It is found on land.      | ✓         |   | ✓ |
| It can make its own food. |           | ✓ | ✓ |

Based on her observations, which of the following best represent organisms A, B and C?

|     | A           | B          | C                |
|-----|-------------|------------|------------------|
| (1) | mushroom    | pine tree  | hydrilla         |
| (2) | rose plant  | hydrilla   | ladder fern      |
| (3) | ladder fern | duckweed   | pine tree        |
| (4) | mould       | water lily | bird's nest fern |

7. During a trip to the school eco-garden, Cindy was asked to look out for a type of aquatic plant. Before the trip, her teacher had given her some descriptions about the aquatic plant.

Based only on Cindy's observation, which of the following descriptions given by her teacher would help her to identify the aquatic plant?

- A It has an edible fruit.
- B It can float on the water
- C It has a swollen leaf stalk.
- D It has purple coloured flowers.
- E It can be grown in different types of water.

- (1) A, C and E only
- (2) B, C and D only
- (3) B, C, D and E only
- (4) A, B, C, D and E

8. During a Science lesson, 4 pupils made the following statements about fungi.

- Raj : Fungi cannot make their own food.  
Eric : Fungi exist as micro-organism only.  
Nurul : Fungi produce spores for reproduction.  
Keisha : Fungi have roots to help them absorb water.

Which pupils had made the **correct** statement?

- (1) Raj and Nurul only                      (2) Eric, Raj and Nurul  
(3) Eric and Keisha only                   (4) Raj, Nurul and Keisha

9. The diagram below shows plant Z.

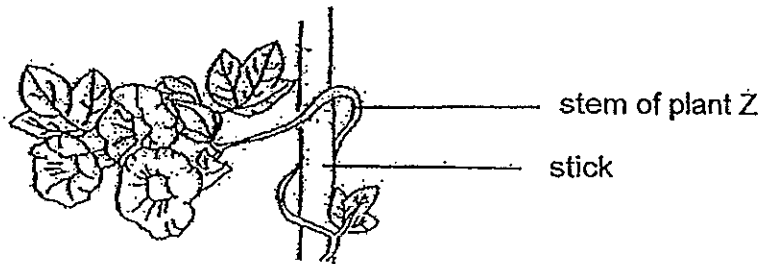

The stem of plant Z is weak and it twirls around the stick.

Which one of the following is the best reason for the plant to twirl its stem around the stick?

- (1) It allows plant Z to grow taller.  
(2) It allows the leaves of plant Z to obtain more air.  
(3) It allows plant Z to get water and mineral salts from the stick.  
(4) It allows the leaves of plant Z to obtain as much sunlight as possible.

10. Four pieces of bread were left undisturbed for a week as shown below. Which bread was most likely to have mould growing on it first?

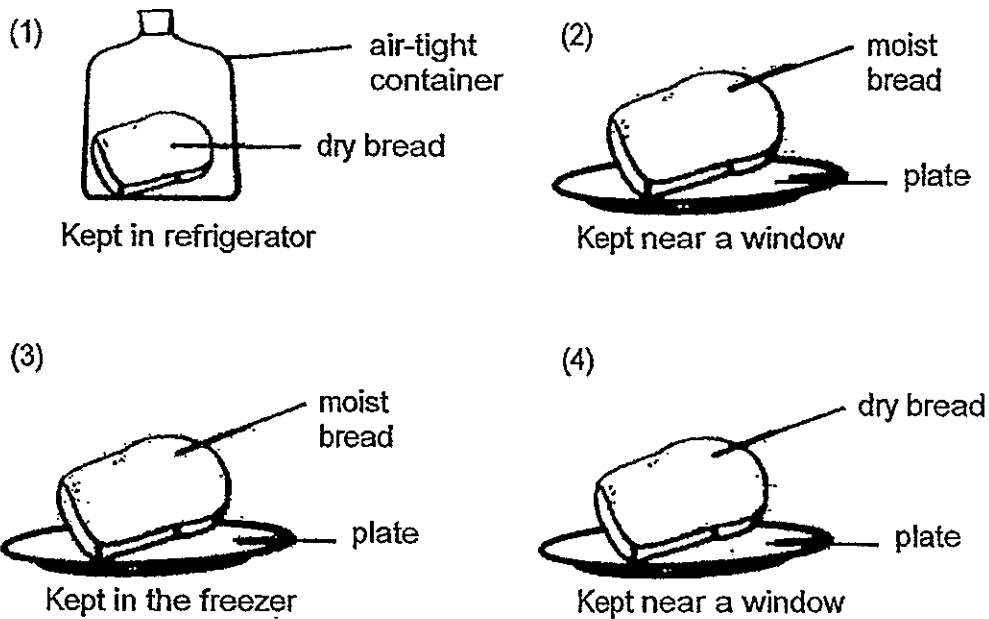

11. Hafiz classified the following organisms into two groups, as shown in the classification table below.

| X  | Y                                  |
|--|------------------------------------|
| papaya tree<br>tomato plant<br>frangipani tree | moss<br>toadstool<br>staghorn fern |

Which one of the following best represents the headings, X and Y?

|     | X                   | Y                   |
|-----|---------------------|---------------------|
| (1) | Non-poisonous plant | Poisonous plant     |
| (2) | Can make food       | Cannot make food    |
| (3) | Flowering plant     | Non-flowering plant |
| (4) | Reproduce by seeds  | Reproduce by spores |



12. Which one of the following sets consists of a floating plant, a partially submerged plant and a fully submerged plant?

- (1) water lily, cattail, cabomba
- (2) hydrilla, cabomba, duckweed
- (3) water hyacinth, water lily, hydrilla
- (4) water hyacinth, duckweed, cattail

13. Nathan made some observations about organism P and recorded his observations in the chart as shown below.

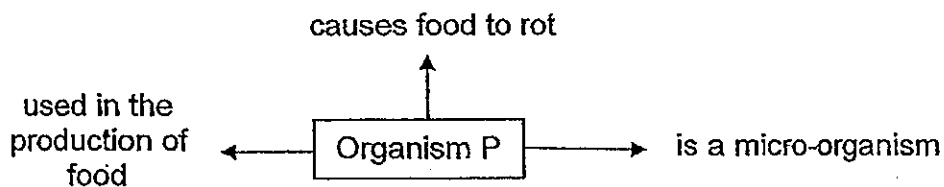

Which of the following could represent organism P?

- (1) yeast and bacteria
- (2) yeast and toadstool
- (3) bracket fungus and mould
- (4) bracket fungus and bacteria

14. Study the table below.

|                                | Organisms |     |
|--------------------------------|-----------|-----|
|                                | G         | H   |
| Does it have green leaves?     | No        | Yes |
| Does it make its own food?     | Yes       | Yes |
| Does it have fragrant flowers? | Yes       | No  |
| Does it float on water?        | No        | No  |

Which one of the following can be definitely be concluded based on the table above?

- (1) Both G and H are plants.
- (2) Both G and H are land plants.
- (3) G is a toadstool but H is a plant.
- (4) G is a flowering plant while H is a non-flowering plant.

15. Study the two groups of living things listed below.

| A         | B     |
|-----------|-------|
| Platypus  | Dog   |
| Goldfish  | Molly |
| Cockroach | Whale |

Which characteristic has been used to classify the living things?

- (1) Number of legs
- (2) Form of movement
- (3) Type of body covering
- (4) Reproduction methods

16. Which one of the following animals lays eggs?

- (1) Fly
- (2) Bat
- (3) Lion
- (4) Whale

17. The characteristics of two animals are given in the table below. A tick (✓) means the animal possess that characteristic.

| Characteristic                   | Animal X | Animal Y |
|----------------------------------|----------|----------|
| Able to fly                      |          |          |
| Gives birth to young alive       |          | ✓        |
| Have hair as their body covering |          | ✓        |

From the information given above, which of the following animals best represents X and Y?

|     | Animal X | Animal Y       |
|-----|----------|----------------|
| (1) | Owl      | Lizard         |
| (2) | Eel      | Spiny anteater |
| (3) | Kiwi     | Bear           |
| (4) | Parrot   | Whale          |

18. A group of pupils came across animal Z. They made the following statements about this animal.

- It can fly.
- It has six legs.
- It reproduces by laying eggs.

What could animal Z be?

- (1) Ostrich
- (2) Penguin
- (3) Dragonfly
- (4) Seahorse

19. Which one of the following is a characteristic that all insects have?

- (1) They can fly.
- (2) They have two body parts.
- (3) They breathe through their breathing holes.
- (4) They have eight jointed legs attached to the thorax.

20. Which pair of animals has been classified ~~wrongly~~ <sup>correctly</sup>?

|     | Has hair  | Has scales |
|-----|-----------|------------|
| (1) | tiger     | tortoise   |
| (2) | duck      | goldfish   |
| (3) | rabbit    | eel        |
| (4) | crocodile | earthworm  |

21. Which one of the following comparisons between a crow and bat is true?

|     | Crow              | Bat                        |
|-----|-------------------|----------------------------|
| (1) | Can fly           | Cannot fly                 |
| (2) | Has hair          | Has feathers               |
| (3) | Lays eggs         | Gives birth to young alive |
| (4) | Suckles its young | Does not suckle its young  |

22. Study the information about animal M in the graphic organiser below.

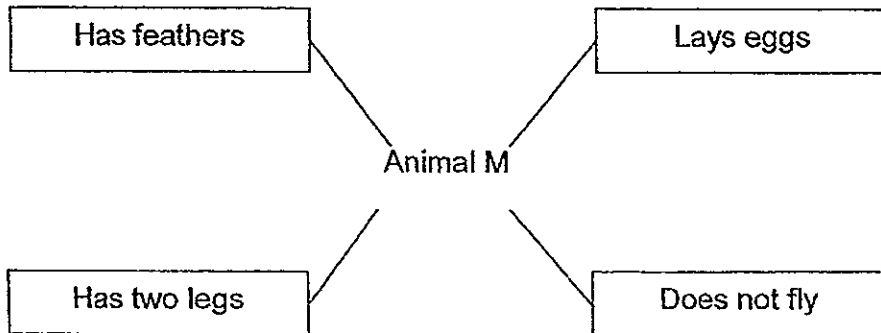

Which one of the following animals best represents animal M?

- (1) Emu
- (2) Seagull
- (3) Dragonfly
- (4) Silverfish

23. Study the animals shown below.

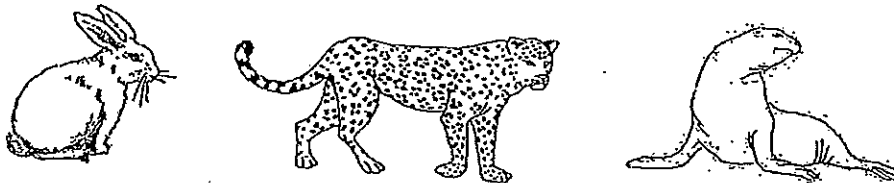

Which of the following statements are true for all the animals above?

- A They have hair.
- B They are warm-blooded.
- C They reproduce by laying eggs.
- D They breathe through their lungs.

- (1) A and B
- (2) C and D
- (3) A, B and C
- (4) A, B and D

24. Karen had to classify the <sup>three</sup> four animals shown below.

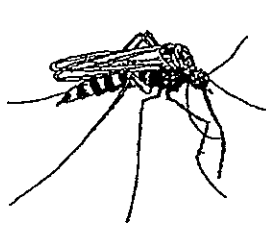

mosquito



seahorse

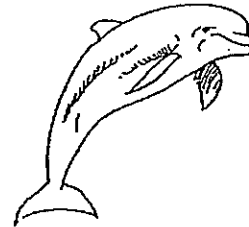

dolphin

She classified them with the help of the chart below.

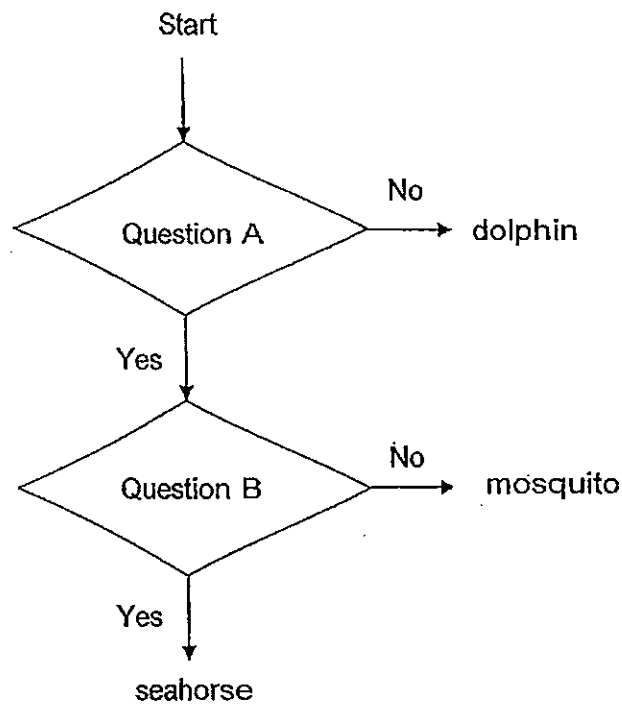

Which of the following could represent Questions A and B?

|     | Question A                     | Question B                     |
|-----|--------------------------------|--------------------------------|
| (1) | Does it lay eggs?              | Does it breathe through gills? |
| (2) | Does it breathe through gills? | Does it lay eggs?              |
| (3) | Does it lay eggs?              | Does it have wings?            |
| (4) | Does it breathe through gills? | Does it have wings?            |

25. Sally classified the following shapes into four groups as shown below.

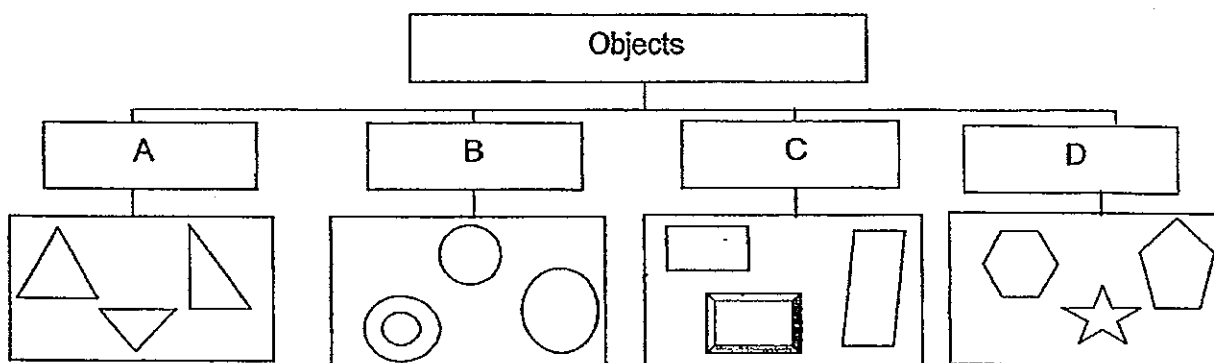

In which group should she place the object shown below?

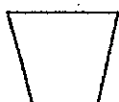

- (1) A
- (3) C

- (2) B
- (4) D

26. Study the picture below.

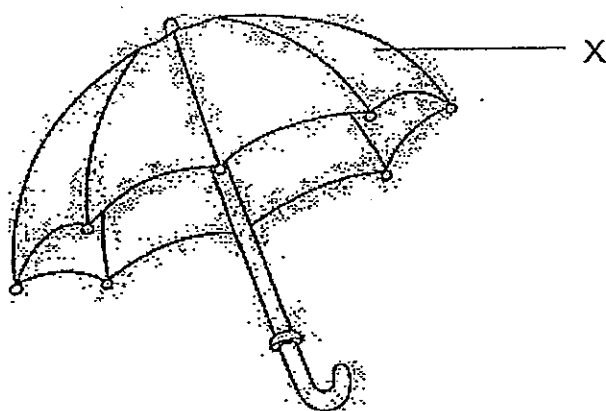

Which of the following are the characteristics that the material for part X must have?

- (1) waterproof and hard
- (2) transparent and hard
- (3) waterproof and flexible
- (4) transparent and flexible

27. Carl conducted an experiment to find out if some objects would sink or float in water. He did this by putting the objects into a basin of water. He filled in the classification chart below based on what he observed but made a few mistakes.

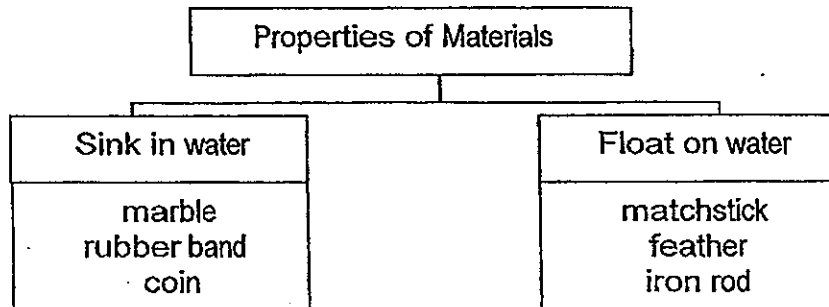

Which of the following objects had been classified wrongly?

- (1) ~~needle~~ <sup>iron rod</sup> and coin
- (2) marble and feather
- (3) marble and matchstick
- (4) rubber band and iron rod
28. Li Li wanted to compare the hardness of four different materials, A, B, C and D. She scratched them, one at a time, with rods made from wood, plastic and metal.

She recorded her observation in the table below.

A tick (✓) indicates the presence of scratch mark made by each rod on the materials.

| Material | Presence of scratch marks made by |            |           |
|----------|-----------------------------------|------------|-----------|
|          | Plastic rod                       | Wooden rod | Metal rod |
| A        | ✓                                 | ✓          | ✓         |
| B        |                                   |            | ✓         |
| C        |                                   | ✓          | ✓         |
| D        |                                   |            |           |

Which of the following statements is true based on the experiment above?

- (1) Material A is the hardest of all.
- (2) Material B is harder than material A.
- (3) Material C is harder than material B.
- (4) Material C is able to scratch material D.

For Questions 29 and 30, refer to the diagram below.

An experiment was carried out as shown in the diagram below. Four different types of materials, W, X, Y and Z, were placed over two pillars at one time. Bricks were stacked on the material until it broke.

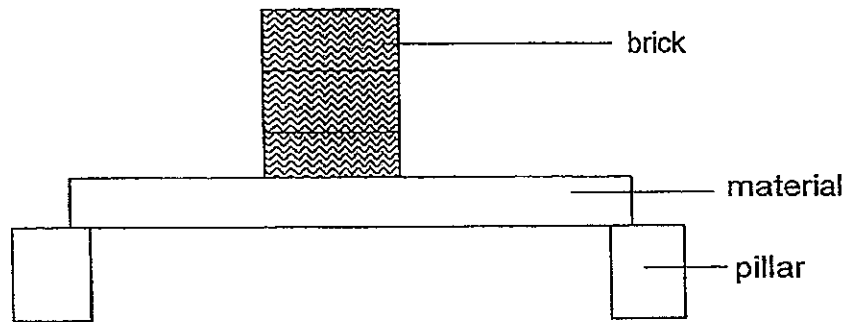

Before the experiment

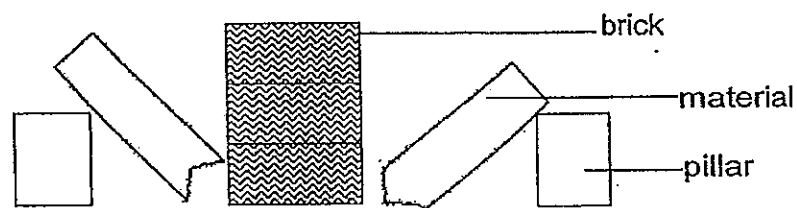

After the experiment

The bar graph below shows the number of bricks placed on each of the materials before it broke.

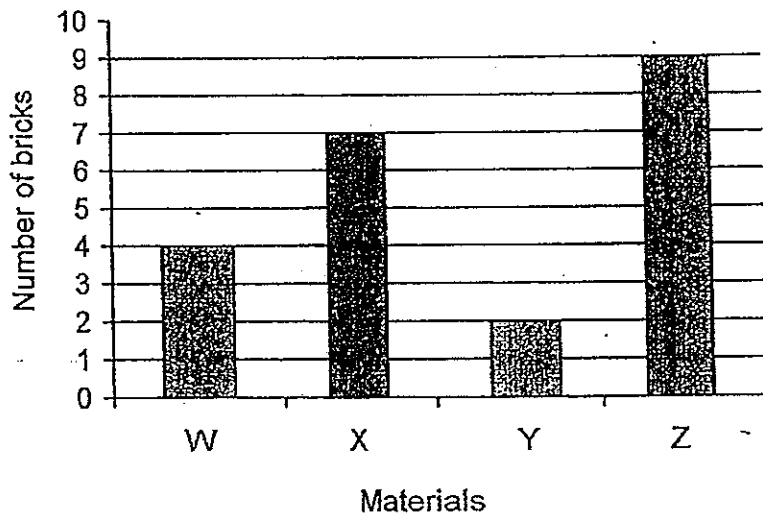



29. What was the aim of this experiment?

- (1) To find out which material bends easily.
- (2) To find out which material is the hardest.
- (3) To find out which material is the strongest.
- (4) To find out which material is the least flexible.

30. Which material, W, X, Y or Z, would be the most suitable to make a bench?

- (1) W
- (3) Y

- (2) X
- (4) Z

**NANYANG PRIMARY SCHOOL**

**PRIMARY THREE SCIENCE**

**SEMESTRAL ASSESSMENT 1  
2013**

**BOOKLET B**

Date : 14 May 2013

Duration : 1 h 45 min

Name : \_\_\_\_\_ ( )

Class: Primary 3 ( )

Marks Scored:

|             |  |     |
|-------------|--|-----|
| Booklet A:  |  | 60  |
| Booklet B : |  | /40 |
| Total :     |  | 100 |

Any query on marks awarded should be raised by 22 May 2013. We seek your understanding in this matter as any delay in the confirmation of marks will lead to delays in the generation of results.

Parent's signature: .....

**DO NOT OPEN THIS BOOKLET UNTIL YOU ARE TOLD TO DO SO.  
FOLLOW ALL INSTRUCTIONS CAREFULLY.**

Booklet B consists of 12 printed pages including this cover page.

**Section B (40 marks)**

Write your answers to questions 31 to 44 in the spaces provided.  
Marks will be deducted for misspelt key words.

31. Four insects, A, B, C and D, of the same kind were kept under different living environment as shown in the table below. A tick (✓) indicates the presence of the condition given to the insect.

| Insects | Conditions for animals |      |       |          |
|---------|------------------------|------|-------|----------|
|         | Air                    | Food | Water | Sunlight |
| A       | ✓                      |      | ✓     | ✓        |
| B       | ✓                      | ✓    |       | ✓        |
| C       | ✓                      | ✓    | ✓     |          |
| D       |                        | ✓    | ✓     | ✓        |

Based on the basic needs of living things, arrange the insects from the insect that will die first to the insect that will die last. [2]

|  |  |  |  |
|--|--|--|--|
|  |  |  |  |
|--|--|--|--|

Insect dies first  → dies last

32. Draw lines to correctly match the animals shown below to the way that they move. [2]

|          |   |  |   |                      |
|----------|---|--|---|----------------------|
| penguin  | ❖ |  | ❖ | hopping and flying   |
| ladybird | ❖ |  | ❖ | hopping and swimming |
| frog     | ❖ |  | ❖ | walking and swimming |
| sparrow  | ❖ |  | ❖ | crawling and flying  |

33. The diagram below shows a tray which has been divided into four equal sections, A, B, C and D. Sections A and C are covered with a black cloth while sections B and D are exposed to the sun for the duration of the experiment. One earthworm is placed on each section of the tray and it is free to move around the entire tray.

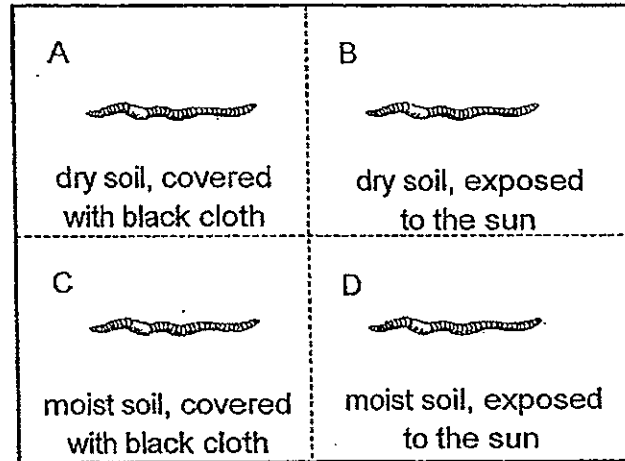

- (a) i) After a few hours, in which of the <sup>section</sup> ~~trays~~ would most of the earthworms be found? [1]

---

- ii) Explain your answer in (i). [1]

---



---

- (b) State two characteristics of living things that are shown in this experiment. [2]

1) 

---

---

2) 

---

---

34. The following table provides some information on four plants, W, X, Y and Z, based on two characteristics. A tick (✓) shows that the plant has the characteristic.

| Characteristics | Plant W | Plant X | Plant Y | Plant Z |
|-----------------|---------|---------|---------|---------|
| Bears fruit     |         | ✓       | ✓       |         |
| Grows in water  |         | ✓       |         | ✓       |

- (a) Based on the information given in the table above, group all the plants by placing the letters, W, X, Y and Z in the correct boxes provided below. [2]

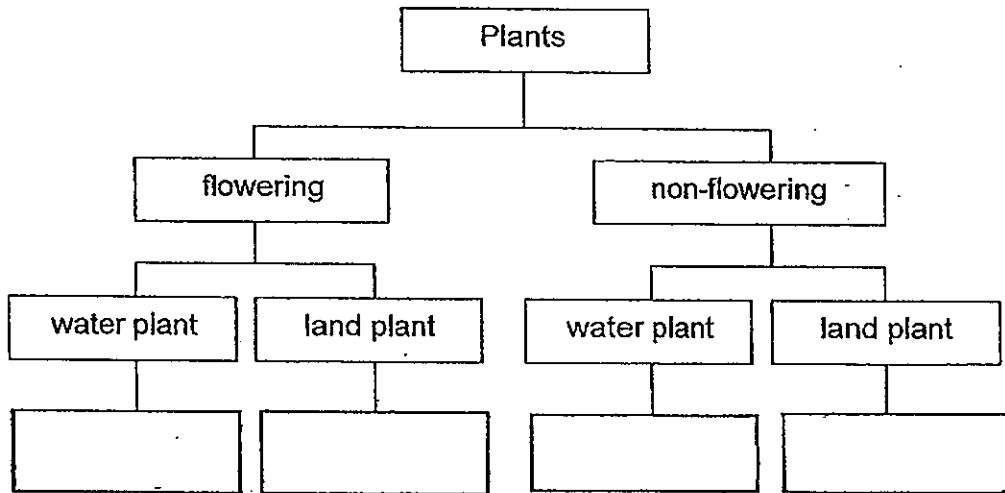

- (b) Based on the information given in the table above, give an **example** of Plant X and Plant W. [1]

Plant X : \_\_\_\_\_

Plant W : \_\_\_\_\_

35. Study the flowchart below carefully.

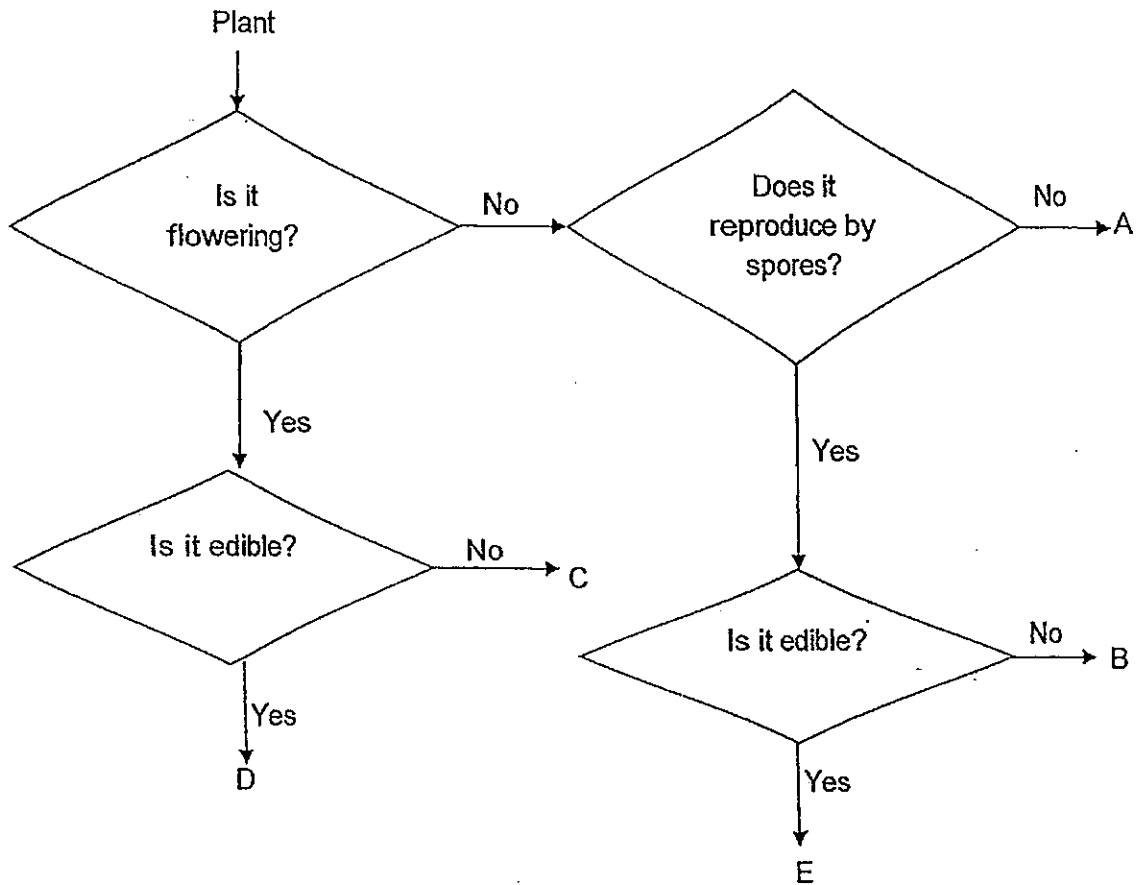

(a) Which letters, A, B, C, D or E, could represent the plants shown below? [2]

(i) Rambutan tree : \_\_\_\_\_

(ii) Pine tree : \_\_\_\_\_

(b) Based on the flowchart above, state one **similarity** between plants B and C. [1]

---



---

36. Sandy made a few statements about plants.

(a) For each of the following statements below, put a tick [✓] in the correct box to indicate if the statements are True or False. [2]

| Statement  | True | False |
|--|------|-------|
| A plant that is observed to have no flowers during winter is definitely a non-flowering plant. |      |       |
| Pong pong is a non-flowering plant.  |      |       |
| All non-flowering plants reproduce by seeds.   |      |       |
| Elodea is a fully submerged plant.   |      |       |

(b) Keith also observed two types of plants, E and F, at the garden, as shown in the diagrams below.

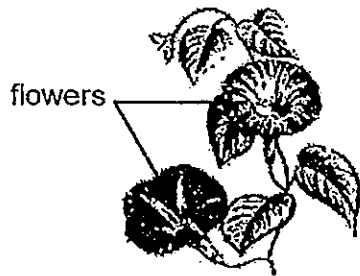

E

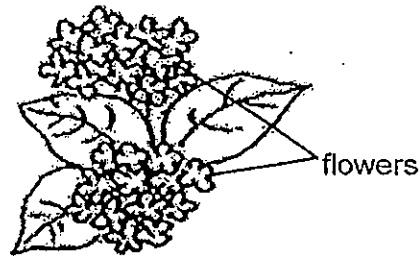

F

The classification chart below shows plants E and F which had been classified based on the way their flowers grow.

Provide the sub-headings to complete the classification chart. [1]

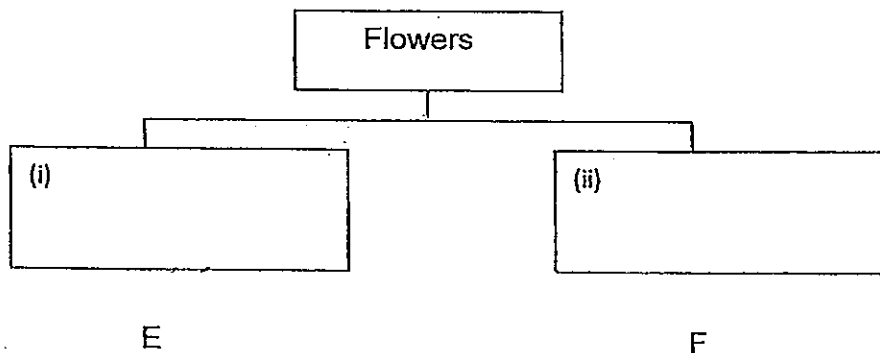

37. Study the classification chart below.

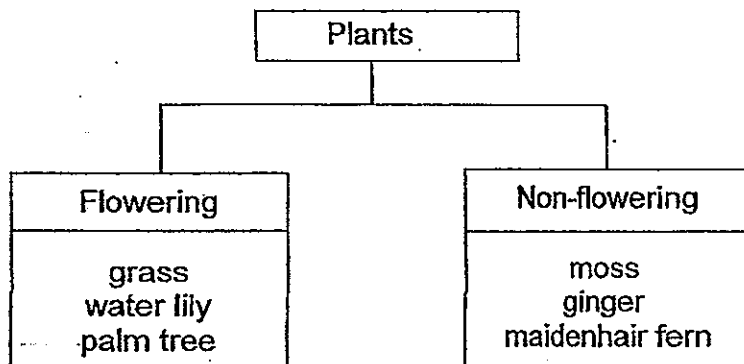

(a) Which one of the organisms above had been classified wrongly? [1]

\_\_\_\_\_

(b) Classify the six plants above in another way, using a different characteristic.

Give a heading for the classification table below. [2]

|  |  |
|--|--|
|  |  |
|  |  |



38. Xin Hui bought two similar pots of plants, like the one shown in the diagram below.

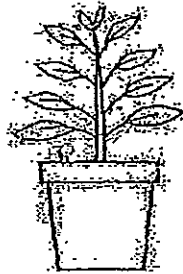

She placed one pot of plant in a **clear glass box** and another pot of plant in a **cardboard box**. Both plants were placed in a sunny area and watered every day.

Draw how both plants in each box would look like after a week. [2]

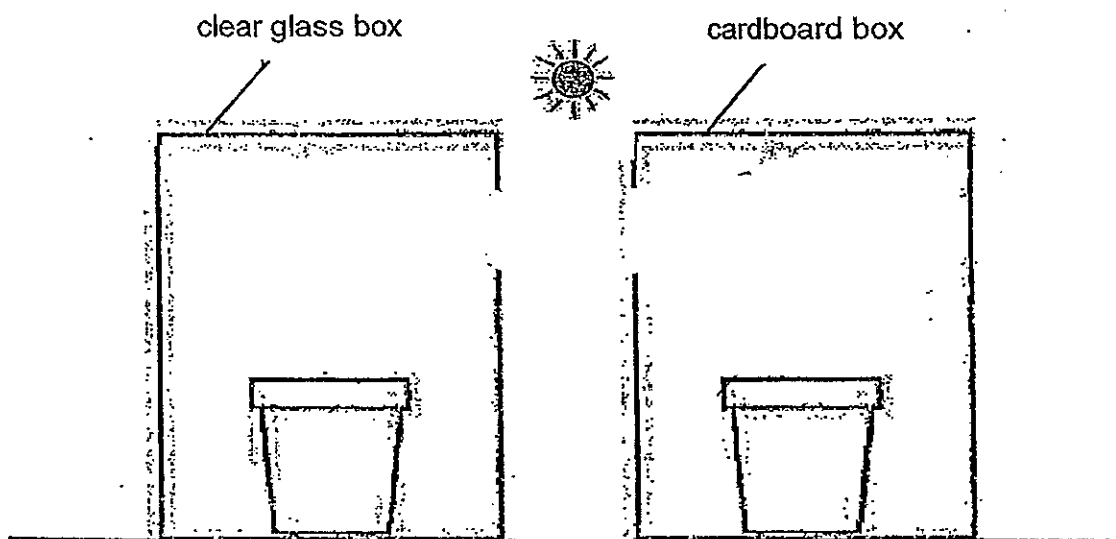

39. Study the flow chart below.

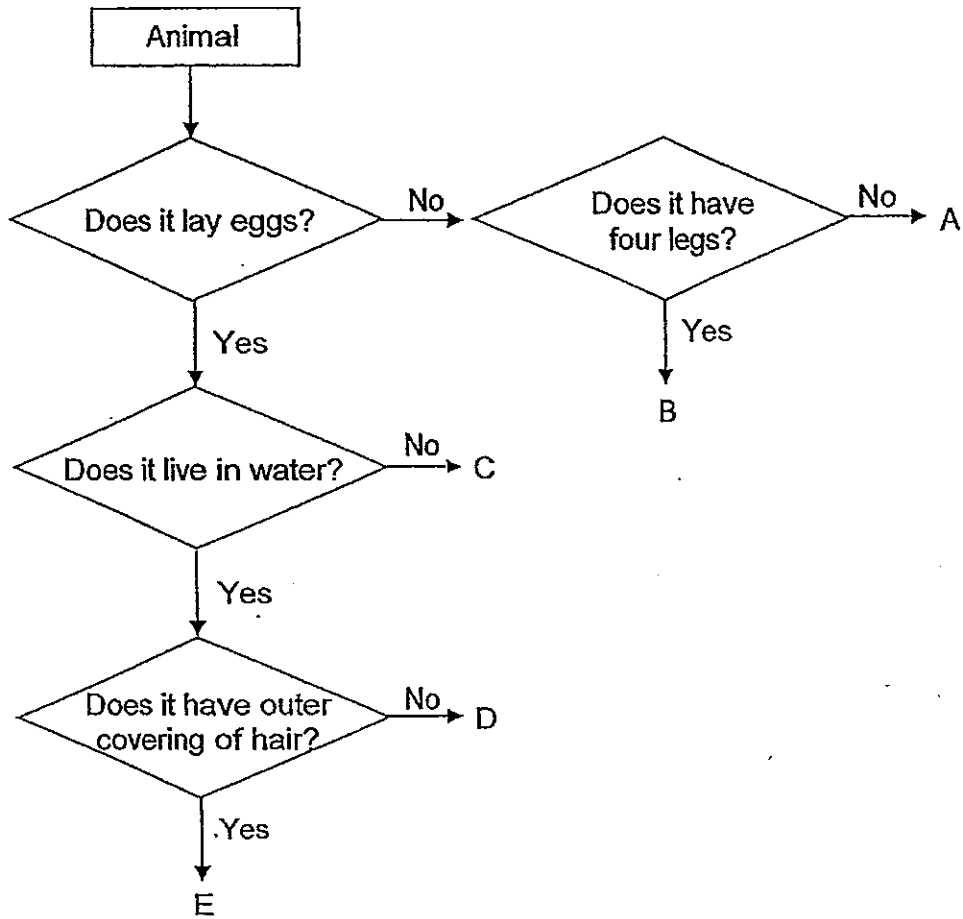

(a) Describe the characteristics of animal B. [1]

---

---

(b) Give an example of an animal that can be represented by E. [1]

---

(c) John said that the swordtail is an example of animal C. Explain whether John had given a correct example of animal C. [2]

---

---

---

40. Study the classification table below. The animals have been grouped based on their outer covering.

| Animals        |         |           |
|----------------|---------|-----------|
| Group P        | Group Q | Group R   |
| Goat           | Kiwi    | Snake     |
| Whale          | Duck    | Goldfish  |
| Spiny anteater | Sparrow | Crocodile |

- (a) State a suitable heading for groups P, Q and R. [3]

Group P : \_\_\_\_\_

Group Q: \_\_\_\_\_

Group R: \_\_\_\_\_

- (b) Explain why 'frog' could not be classified in the table above. [1]

\_\_\_\_\_

\_\_\_\_\_

41. Study the diagrams below. Based only on the diagrams, state one similarity and one difference between animal X and Y. Do not compare their shape, size and colour. [2]

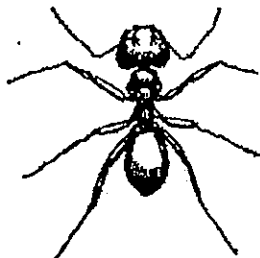

Animal X



Animal Y

Similarity: \_\_\_\_\_

\_\_\_\_\_

Difference: \_\_\_\_\_

\_\_\_\_\_

42. Salina took out an orange from her cupboard. It had been left there for a month and she found a patch of green substance growing on it.

(a) What could the green substance be? [1]

\_\_\_\_\_

(b) How did the green substance get onto the orange? [1]

\_\_\_\_\_

\_\_\_\_\_

43. The diagram below shows a hammer.

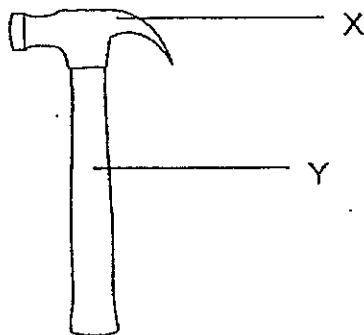

(a) Identify suitable materials used to make parts X and Y. [1]

Part X: \_\_\_\_\_

Part Y: \_\_\_\_\_

(b) State the property of the material used to make Part X.  
Explain why this property makes the material suitable to be used  
in the hammer. [2]

\_\_\_\_\_

\_\_\_\_\_

\_\_\_\_\_

4. Three different materials of the same shape and size were placed into beakers containing 500 ml of water each, as shown in the diagrams below.

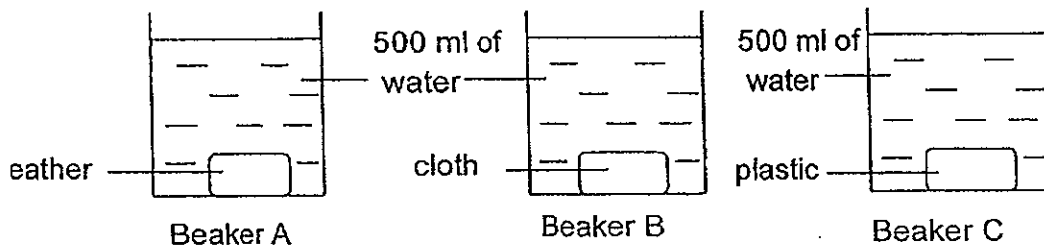

After 30 minutes, the materials were then removed from the beaker and the amount of water left in each beaker was recorded.

- (a) Fill in the amount of water that would be left in beaker C in the table below. [1]

| Beakers | Amount of water left in the beaker (ml) |
|---------|---|
| A       | 480                                     |
| B       | 420                                     |
| C       |   |

- (b) Which material, leather, cloth or plastic; is the most suitable for making a kitchen rag? Explain your answer. [2]

---



---



---

~ End of Paper~

# ANSWER SHEET

**EXAM PAPER 2013**

**SCHOOL : NANYANG PRIMARY SCHOOL**

**SUBJECT : PRIMARY 3 SCIENCE**

**TERM : SA1**

|    |    |    |    |    |    |    |    |    |     |     |     |     |     |     |     |     |
|----|----|----|----|----|----|----|----|----|-----|-----|-----|-----|-----|-----|-----|-----|
| Q1 | Q2 | Q3 | Q4 | Q5 | Q6 | Q7 | Q8 | Q9 | Q10 | Q11 | Q12 | Q13 | Q14 | Q15 | Q16 | Q17 |
| 1  | 3  | 3  | 2  | 1  | 4  | 2  | 1  | 4  | 2   | 4   | 3   | 1   | 1   | 4   | 1   | 3   |

|     |     |     |     |     |     |     |     |     |     |     |     |     |
|-----|-----|-----|-----|-----|-----|-----|-----|-----|-----|-----|-----|-----|
| Q18 | Q19 | Q20 | Q21 | Q22 | Q23 | Q24 | Q25 | Q26 | Q27 | Q28 | Q29 | Q30 |
| 3   | 3   | 1   | 3   | 1   | 4   | 1   | 3   | 3   | 4   | 2   | 3   | 4   |

Section B

Q31) D, B, A, C

Q32)

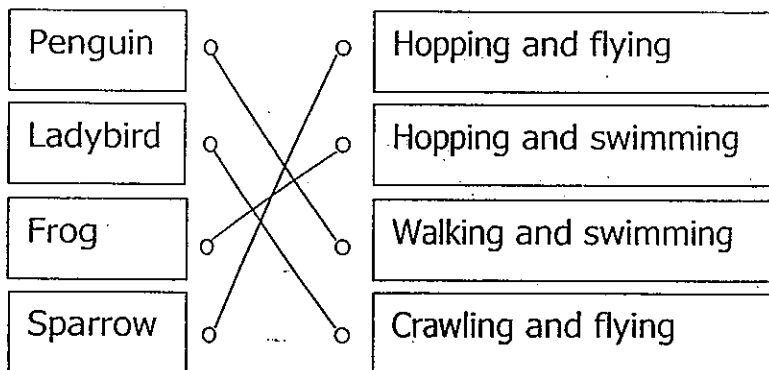

Q33)

a)i) Section C

ii) Earthworms like moist and dark places

b) 1) Living things respond to changes

2) Living things move by themselves

Q34

a)

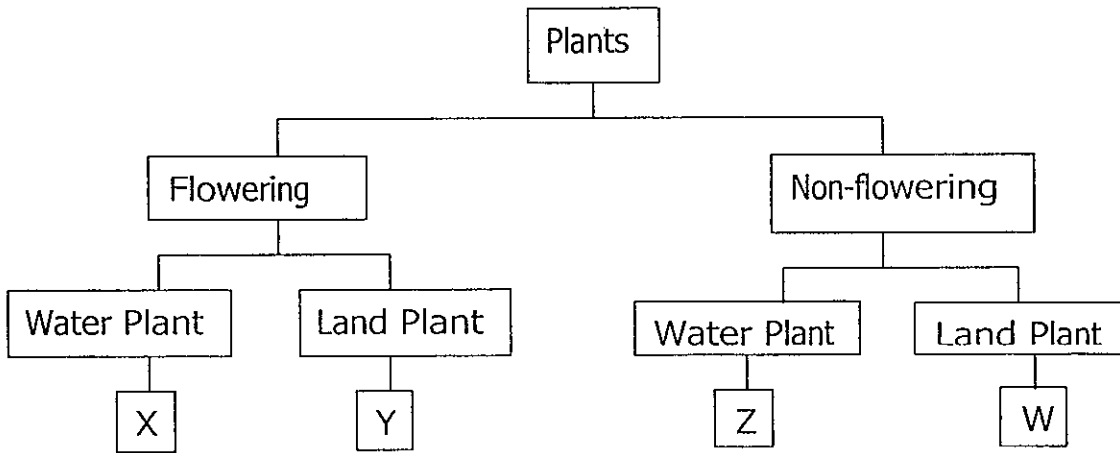

b) Plant X: Water Lily

Plant W: Dragonscale fern

Q35

a) i) D

ii) A

b) Both are not edible

Q36

a)

| Statement   | True | False |
|---|------|-------|
| A plant that is observed to have no flowers during winter is definitely a non-flowering plant |      | ✓     |
| Pong pong is a non-flowering plant  |      | ✓     |
| All non-flowering plants reproduce by seeds   |      | ✓     |
| Elodea is a fully submerged plant   | ✓    |       |

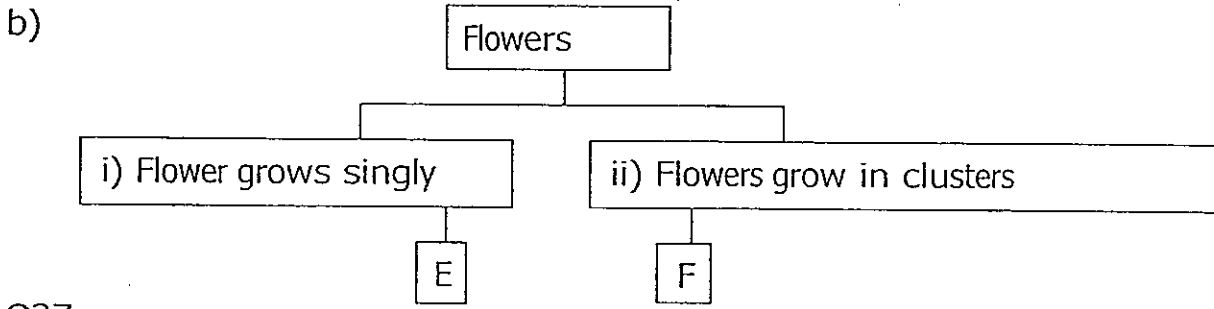

Q37

a) Ginger

b)

| Reproduce by seeds                         | Reproduce by spores        |
|--|----------------------------|
| Grass<br>Water Lily<br>Palm tree<br>Ginger | Moss<br>Maidenhair<br>Fern |

Q38

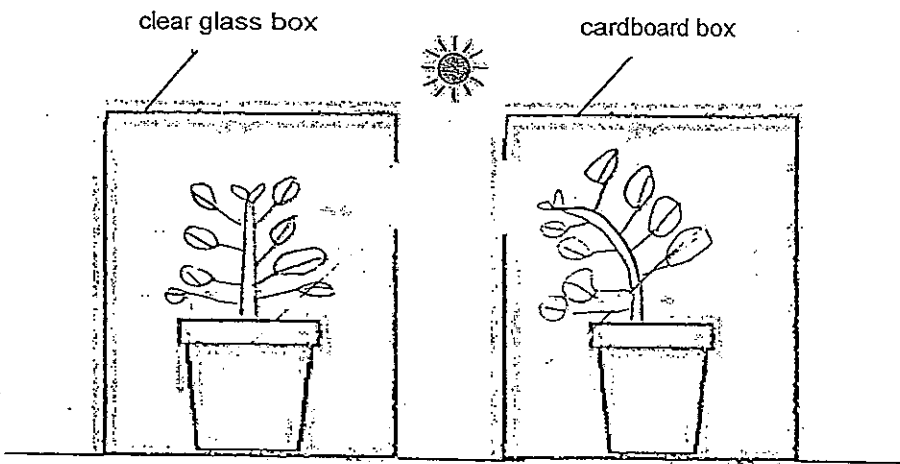

Q39

a) It does not lay eggs and it has four legs

b) Duck-billed platypus

c) No. A swordtail does not lay eggs and lives in water

Q40

a) Group P: Hair

Group Q: Feathers

Group R: Scales

b) Its outer covering is not hair, feathers or scales



Q41) Similarity: Both have six jointed legs  
Difference: Animal Y has wings while animal X does not

Q42

- a) Mould
- b) The spores landed on the orange and grew

Q43

- a) Part X: Metal  
Part Y: Wood
- b) Strong. It will not break easily

Q44

a)

| Beakers | Amount of water left in beaker (ml) |
|---------|-------------------------------------|
| A       | 480                                 |
| B       | 420                                 |
| C       | 500                                 |

- b) Cloth. It absorbs the most water

**Pei Chun Public School**  
**Semestral Assessment 1 – 2013**  
**Science**  
**Primary 3**

Name : \_\_\_\_\_ (    )    Date : 17 May 2013

Class : Pri. 3 (    )

Science Teacher : \_\_\_\_\_

Time : 50 min

**Section A (15 × 2 marks)**

For questions 1 to 15, choose the most suitable answer and shade its number (1, 2, 3 or 4) on the Optical Answer Sheet (OAS) provided.

1. Study the following diagrams.



A



B



C



D

Which of the following need air, food and water to stay alive?

- (1) A and D only
- (2) B and C only
- (3) B and D only
- (4) C and D only

(    )

2. The following leaves, A, B and C, were grouped together according to a common characteristic.

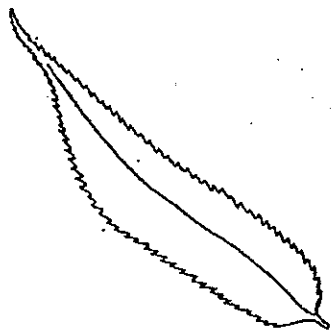

Leaf A

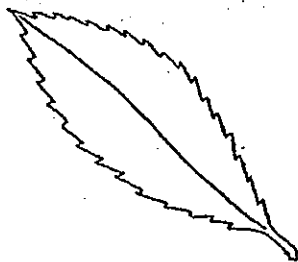

Leaf B



Leaf C

Which of the following leaves could be grouped with leaves A, B and C?

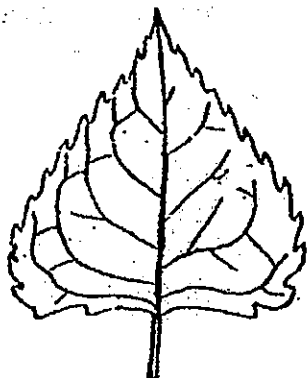

(1)

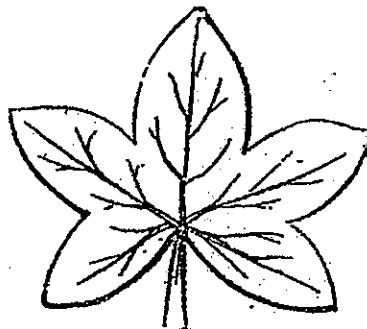

(2)

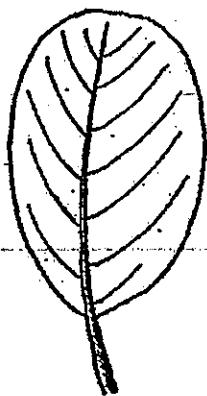

(3)

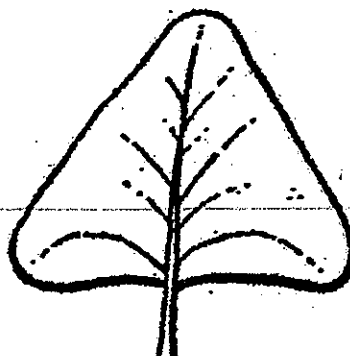

(4)

( )

3. The things below are classified according to their similarities.

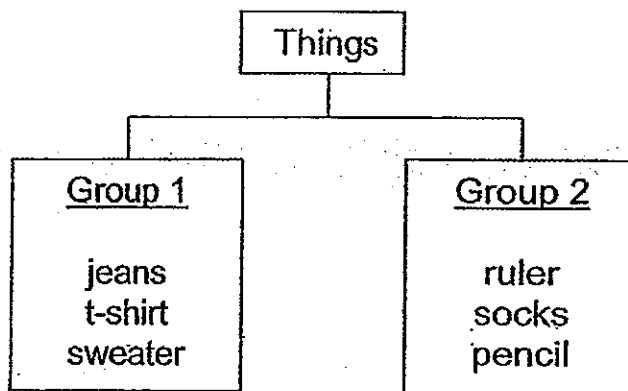

Which of the things is classified wrongly?

- (1) ruler
- (2) socks
- (3) jeans
- (4) sweater

( )

Ethel placed a pot of seedlings next to an open window and left it there for a week as shown below.

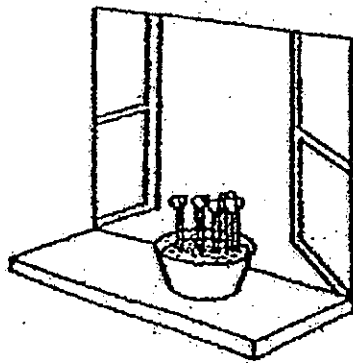

One week later, she noticed that the seedlings had died. Which of the following is the most likely reason?

- (1) The seedlings were not given water.
- (2) The seedlings were not given warmth.
- (3) The seedlings did not receive sunlight.
- (4) The seedlings did not receive enough air.

( )

5. Which of the following statements about living things is/are true?

- A. All living things die.
- B. All living things reproduce by giving birth.
- C. All living things can make their own food.
- D. All living things respond to changes around them.

- (1) A only
- (2) B and C only
- (3) A and D only
- (4) A, B and D only

( )

6. The diagram below shows two plants, P and Q.

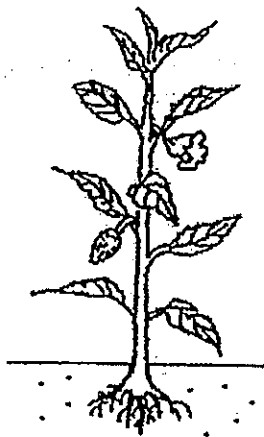

Plant P

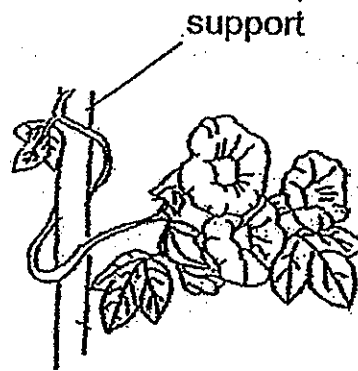

Plant Q

Based on the observations of plants P and Q, which of the following statements is true?

- (1) Plant P grows faster than Plant Q.
- (2) Plant P has a stronger stem than Plant Q.
- (3) Plant Q needs more sunlight than Plant P.
- (4) Plant Q is a flowering plant, but Plant P is not.

( )

7. Study the flowchart carefully.

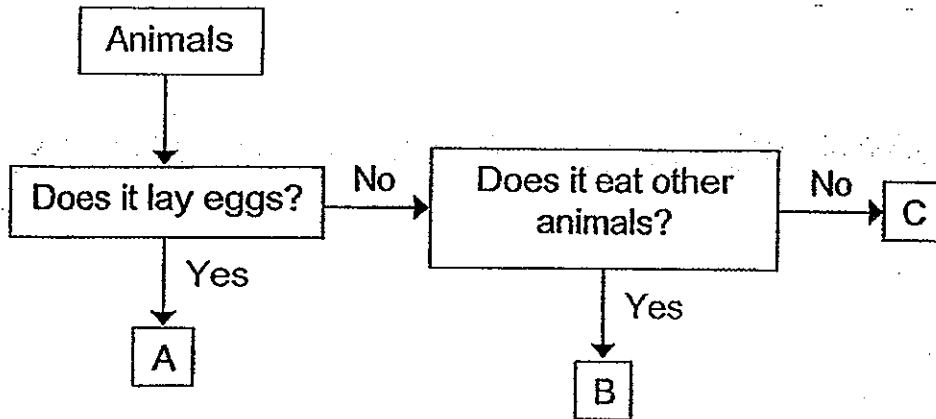

Which of the following can be animals A, B and C?

|     | A          | B       | C         |
|-----|------------|---------|-----------|
| (1) | guppy      | duck    | giraffe   |
| (2) | frog       | lion    | deer      |
| (3) | hen        | cow     | eagle     |
| (4) | fern plant | leopard | crocodile |

8. John classified four organisms in the same group as shown below. Based on the diagrams, which of the organisms did he place in the group wrongly?

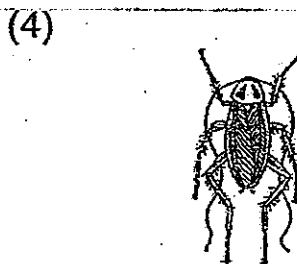
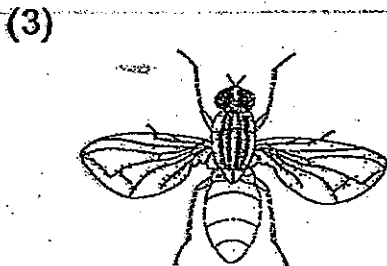
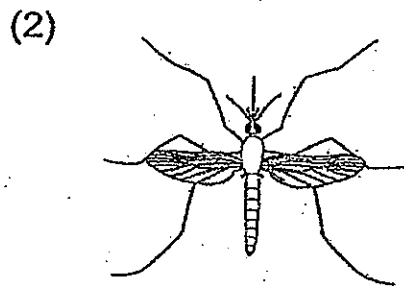
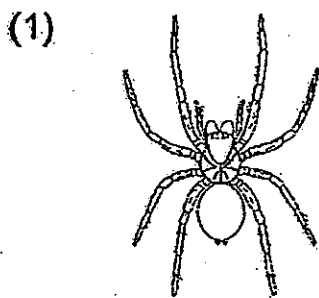

( )

9. The classification diagram below shows animals classified under three different groups P, Q, and R.

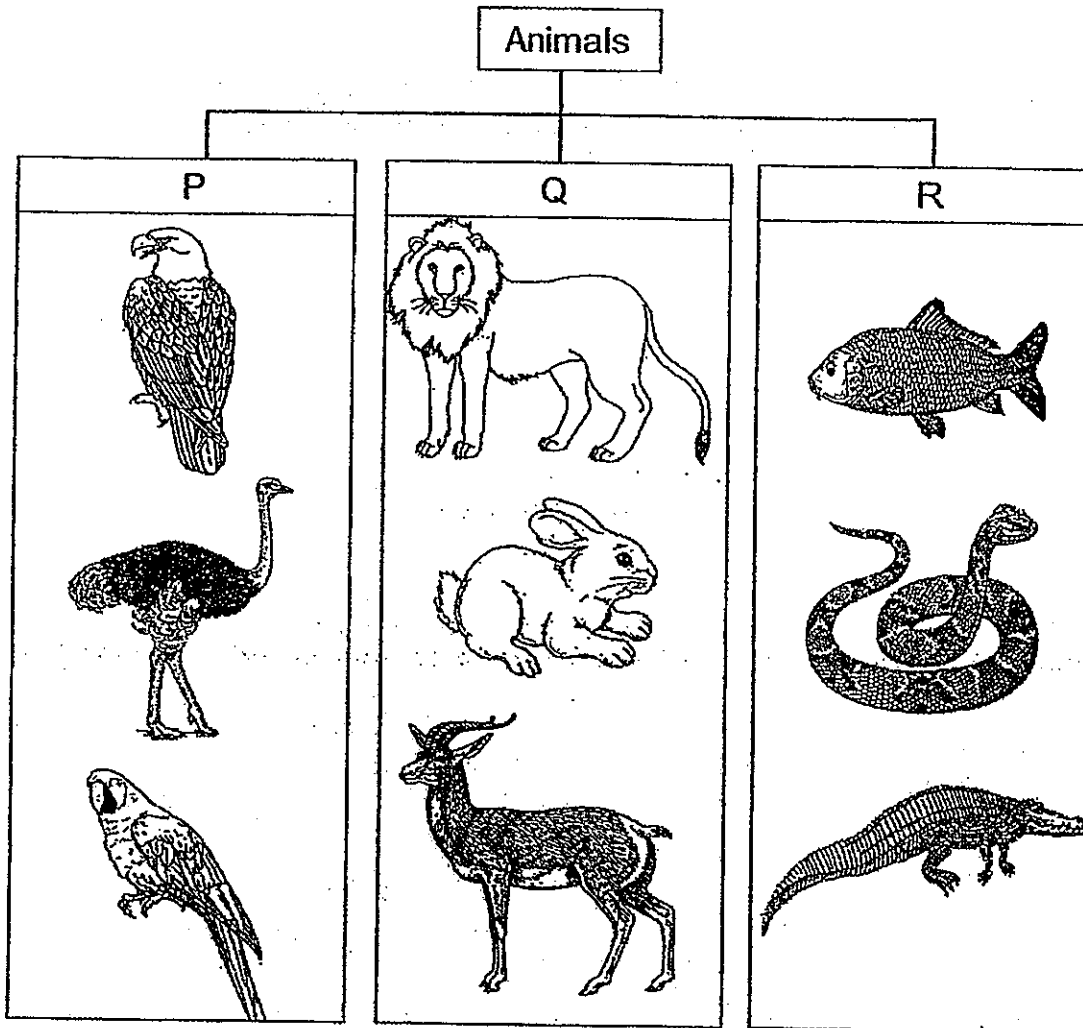

Which of the following groups best represents the above classification?

|     | P             | Q          | R           |
|-----|---------------|------------|-------------|
| (1) | can fly       | can walk   | can swim    |
| (2) | lay eggs      | give birth | give birth  |
| (3) | eat animals   | eat plants | eat animals |
| (4) | have feathers | have hair  | have scales |

( )

10. Four pupils made some statements about bacteria below.

Adelyn: Bacteria can have different shapes.

Bianca: Bacteria can be harmful or useful.

Cassie: Bacteria can make their own food.

Darren: Bacteria can only be seen under a microscope.

Which of the following pupils made a **wrong** statement?

(1) Adelyn

(2) Bianca

(3) Cassie

(4) Darren

( )

11. Alice was playing with a ball inside a house. The diagram below shows what had happened when the ball hit a vase.



Which of the following materials is the vase most likely to be made of?

(1) wood

(2) metal

(3) glass

(4) plastic

( )



12. Study the flowchart carefully.

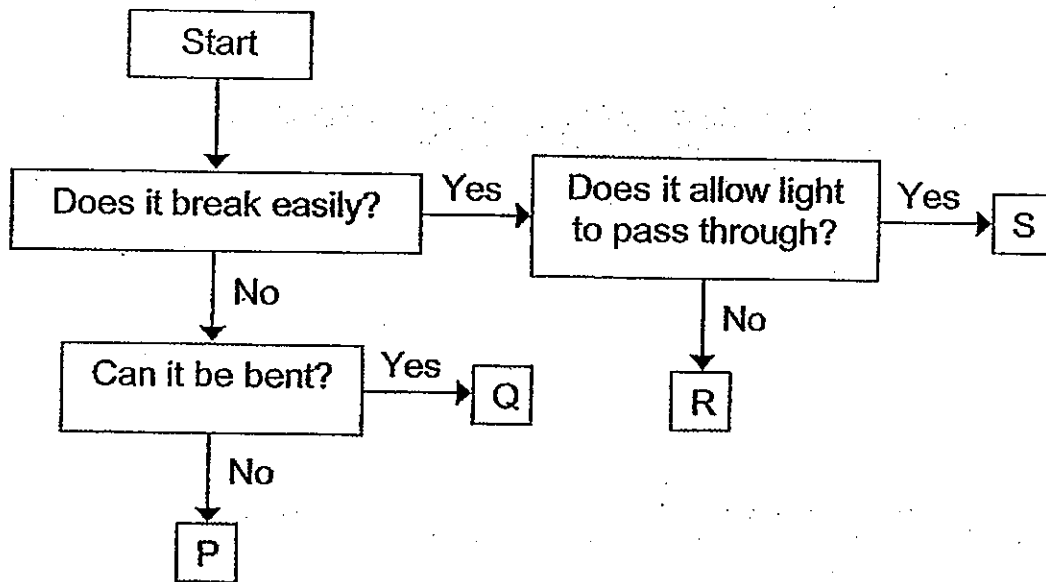

Which of the following best represents P, Q, R and S?

|     | P          | Q          | R          | S          |
|-----|------------|------------|------------|------------|
| (1) | hammer     | paper clip | flower pot | fish tank  |
| (2) | fish tank  | hammer     | paper clip | flower pot |
| (3) | flower pot | fish tank  | hammer     | paper clip |
| (4) | paper clip | flower pot | fish tank  | hammer     |

( )

13. Geraldine conducted an experiment to find out the most suitable conditions best for storing bread. She placed four slices of bread A, B, C and D in different conditions. After one week, she recorded her observations in the table below.

| Bread | Conditions |      |       |     | Observations   |
|-------|------------|------|-------|-----|----------------|
|       | Warm       | Cool | Moist | Dry |                |
| A     |            | ✓    |       | ✓   | no mould       |
| B     | ✓          |      | ✓     |     | a lot of mould |
| C     |            | ✓    | ✓     |     | some mould     |
| D     | ✓          |      |       | ✓   | little mould   |

Based on the information provided, which of the following pairs of conditions is most suitable for storing a loaf of bread?

- (1) cool and dry
- (2) warm and dry
- (3) cool and moist
- (4) warm and moist

( )

14. Jason has four bags, each made of a different material. Each bag is able to hold objects up to a certain weight. The information below shows how much weight each bag can hold without breaking.

| Bag | Amount of weight bag can hold without breaking (kg) |   |   |    |
|-----|---|---|---|----|
|     | 2   | 4 | 8 | 10 |
| A   | ✓   | ✓ |   |    |
| B   | ✓   | ✓ | ✓ | ✓  |
| C   | ✓   |   |   |    |
| D   | ✓   | ✓ | ✓ |    |

Which bag should Jason use to carry an object weighing 9 kg?

- (1) A
- (2) B
- (3) C
- (4) D

( )

15. The diagram below shows a screwdriver.

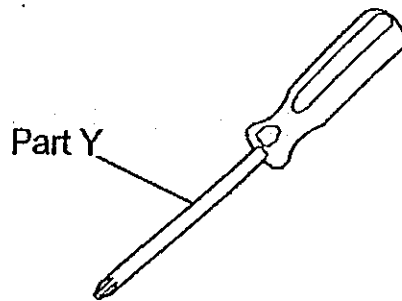

Part Y of the screwdriver is usually made of metal. Which of the following reason(s) best explain(s) why metal is used for Part Y?

- A. Metal is hard.
- B. Metal is shiny.
- C. Metal is strong.
- D. Metal is flexible.

- (1) A only
- (2) A and C only
- (3) B and D only
- (4) A, B and C only

( )

**End of Section A**

**Pei Chun Public School**  
**Semestral Assessment 1 – 2013**  
**Science**  
**Primary 3**

Name: \_\_\_\_\_ (      )

Class: Pri. 3 (      )

Date: 17 May 2013

Time: 50 min

Science Teacher: \_\_\_\_\_

Parent's Signature: \_\_\_\_\_

|           |    |
|-----------|----|
| Section A | 30 |
| Section B | 20 |
| Total     | 50 |

**Section B (20 marks)**

For questions 16 to 22, write your answers in the spaces provided.

16. Study the diagram below carefully.

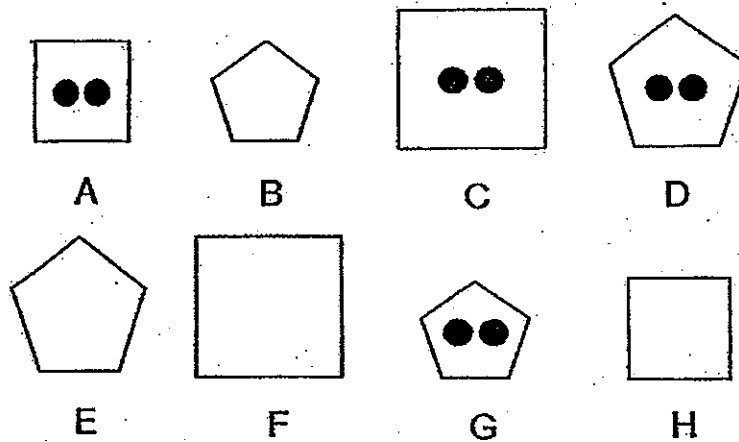

Classify the objects above into two equal groups. (2 m)

| Group A | Group B |
|---------|---------|
|         |         |

17. The set-ups below show two similar hamsters in separate containers.

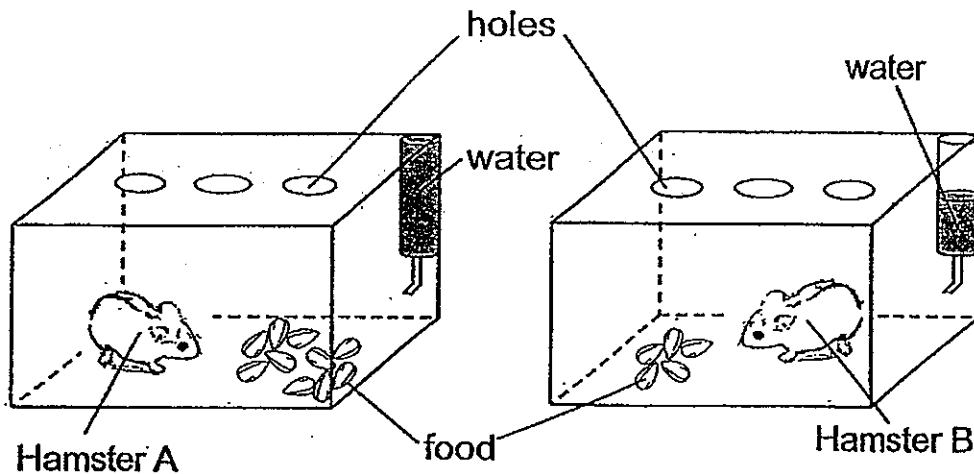

- (a) Based on the above set-ups, which hamster will live longer? (1 m)

---

- (b) Give two reasons for your answer in (a). (2 m)

---



---

18. The diagrams below show two organisms X and Y.



Organism X

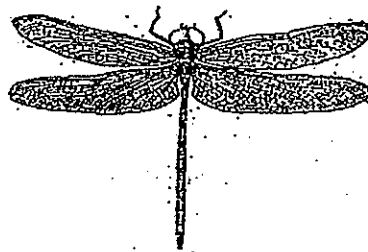

Organism Y

Based on your observations of the organisms from the diagrams above, put a tick (✓) in the box(es) where the statement(s) is/are true. (3 m)

| Statements  | Tick                     |
|---|--------------------------|
| (a) Both organisms have wings.                                  | <input type="checkbox"/> |
| (b) Both organisms reproduce by giving birth.                   | <input type="checkbox"/> |
| (c) Organism X has a beak, but organism Y does not.             | <input type="checkbox"/> |
| (d) Organism X is covered with feathers, but organism Y is not. | <input type="checkbox"/> |

19. Margaret and her friends were having a conversation about whales. Below is what they talked about.

Brandon : Just yesterday, I read in a book that whales have hairs and a tail. They also move like a fish in the water.

Margaret : I watched a television programme saying that whales can stay underwater for very long. They breathe through lungs and occasionally come up to the water surface for air.

Sandrene : I read on the Internet that whales only give birth to one young every two to four years.

(a) Based on the conversation, what type of animals do whales belong to? (1 m)

---

(b) List down one characteristic found in the conversation that supports your answer in (a). (1 m)

---

---

(c) Suggest another animal that belongs to the same type of animals as a whale. (1 m)

---

20. The diagram below shows a mushroom.

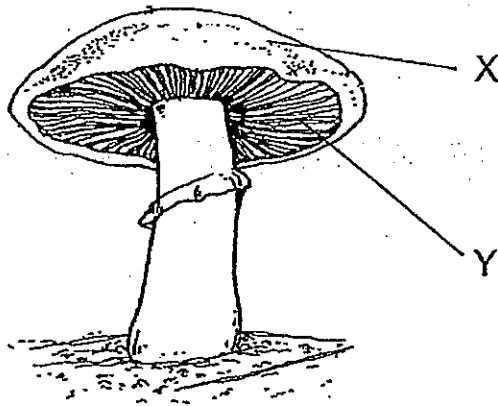

(a) Identify parts X and Y.

(1 m)

X: \_\_\_\_\_

Y: \_\_\_\_\_

(b) Josiah wanted to classify mushroom in the same group as bird's nest fern because both are plants. His teacher told him that his reason was wrong.

Give a reason why Josiah's teacher said his reason was wrong.

(1 m)

---

---

---

(c) Suggest one common characteristic between a mushroom and a bird's nest fern so that they can be grouped together.

(1 m)

---

---

---

21. An experiment was conducted to test the strength of four different materials A, B, C, and D. Weights were dropped from the same height onto each material.

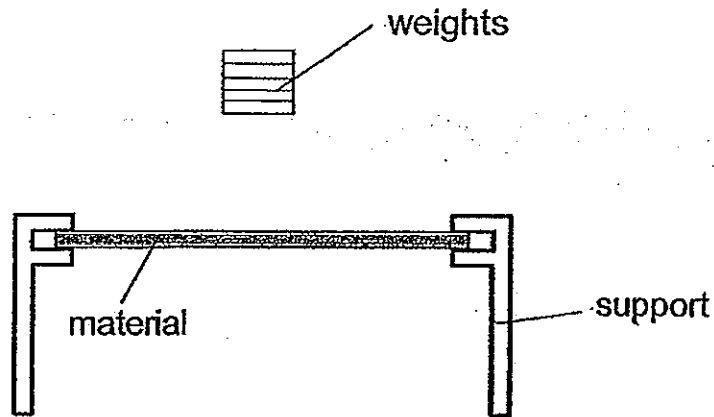

The minimum number of weights required to break each material was recorded in the graph below.

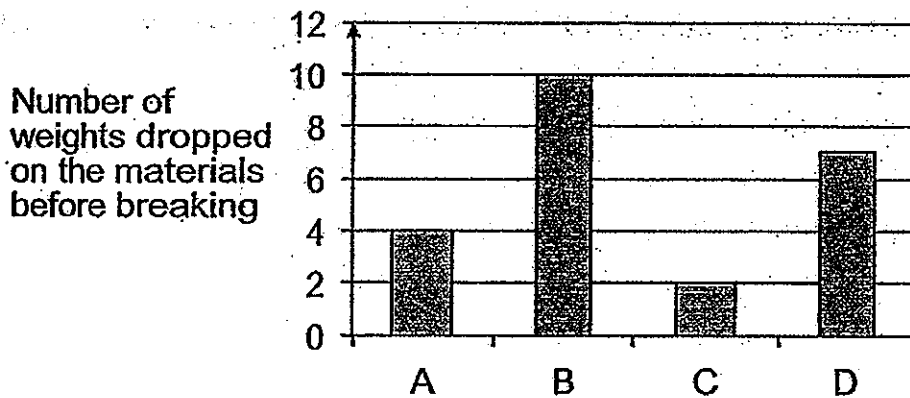

- (a) Which one of the materials (A, B, C or D) is the weakest?

(1 m)

---

- (b) Which one of the materials (A, B, C or D) is the most suitable for making a door?

(1 m)

---

- (c) Give a reason for your answer in (b).

(1 m)

---

---



22. Ahmad conducted an experiment. He hung four different strips of materials in a large container of water. All the strips were of equal length. He then waited for one minute. The diagram below shows the water mark on each piece of material.

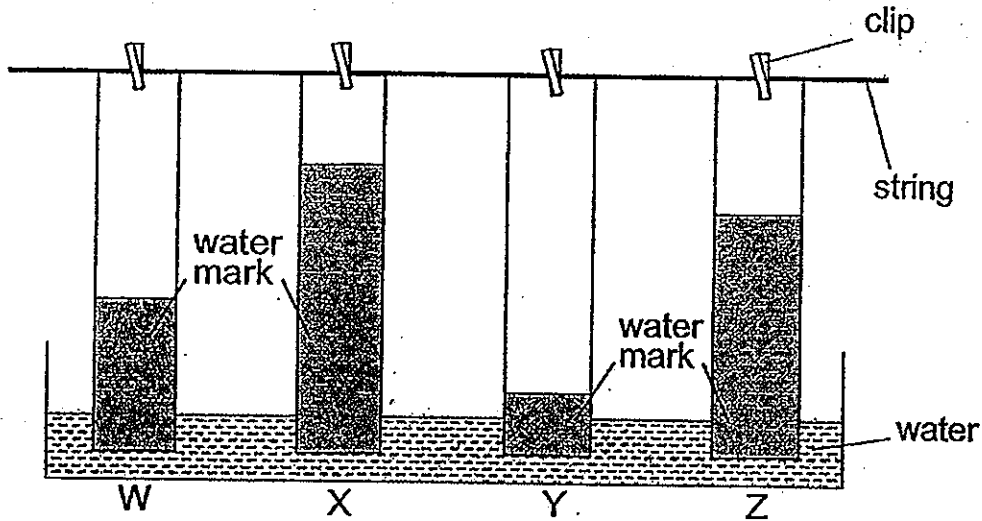

- (a) Based on the diagram above, arrange the materials (W, X, Y, and Z) from the most suitable to least suitable for making a mop. (1 m)

Most suitable  $\longrightarrow$  Least suitable

\_\_\_\_\_ , \_\_\_\_\_ , \_\_\_\_\_ , \_\_\_\_\_

- (b) Ahmad then repeated the experiment with another strip of the same length cut from a raincoat. Will there be any water mark observed on the strip cut from the raincoat? Give a reason your answer. (2 m)

---



---



---



---

**End of Section B**

## Exam Paper 2013 Answer Sheet

**School: PEI CHUN PUBLIC SCHOOL**

**Subject: PRIMARY 3 SCIENCE**

**Term: SA1**

|    |   |     |   |     |   |
|----|---|-----|---|-----|---|
| 1) | 3 | 6)  | 2 | 11) | 3 |
| 2) | 1 | 7)  | 2 | 12) | 1 |
| 3) | 2 | 8)  | 1 | 13) | 1 |
| 4) | 1 | 9)  | 4 | 14) | 2 |
| 5) | 3 | 10) | 3 | 15) | 2 |

16. Group A – A, C, D, G

Group B – B, E, F, H

17. (a) Hamster A.

(b) Hamster A has more food and water than hamster B. Thus, hamster A will live longer.

18. Tick a, c and d.

19. (a) Mammal.

(b) It has hair.

(c) Bat.

20. (a) X: Cap

Y: Gills

(b) The bird nest fern makes food while mushrooms do not make food.

Thus, the mushroom is a fungi, not a plant.

(c) They reproduce by spores.

21. (a) C

(b) B

(c) Material B is the strongest material in the experiment.

22. (a) X, Z, W, Y

(b) There will not be any watermark. Plastic is waterproof.

---

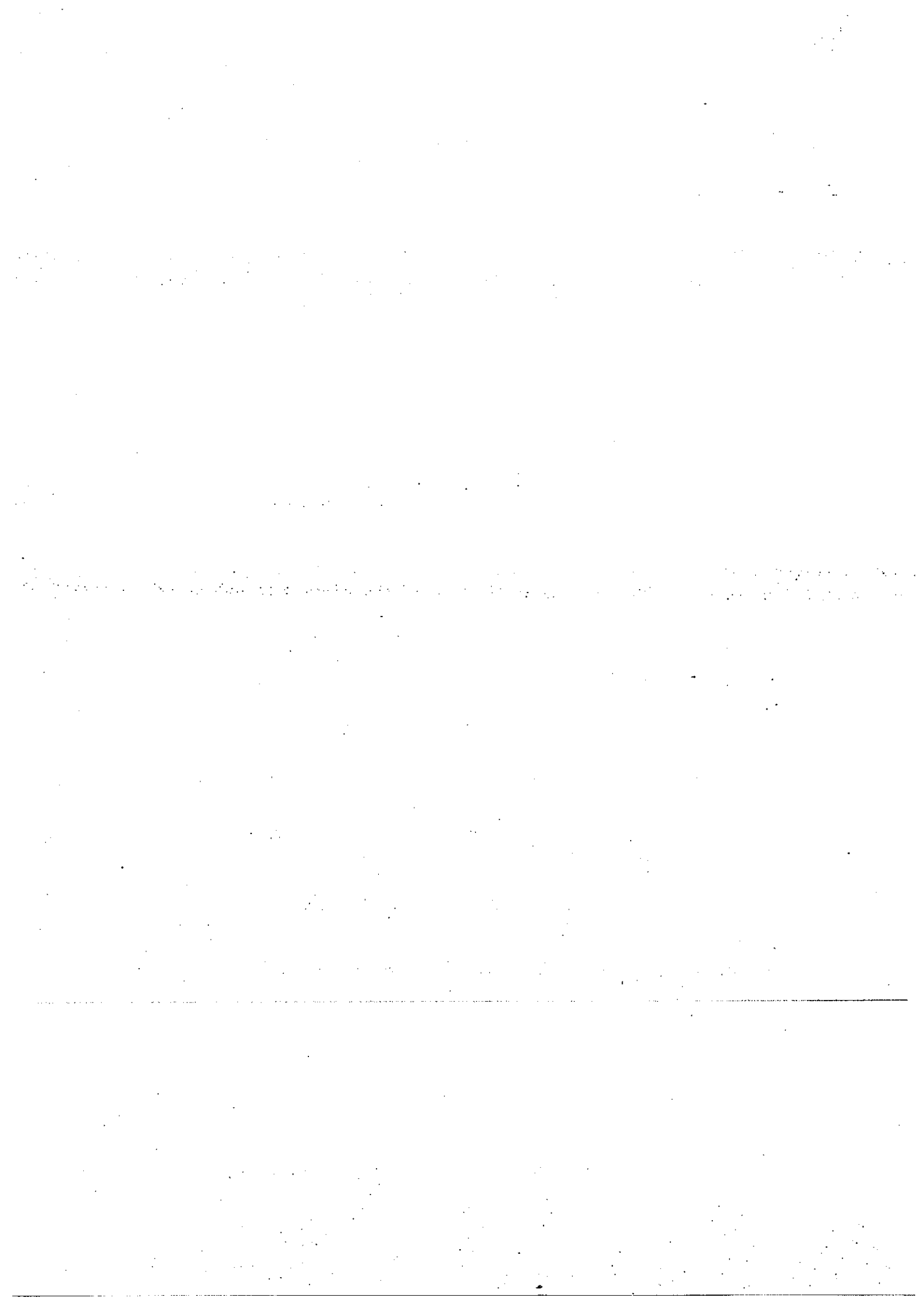



# RAFFLES GIRLS' PRIMARY SCHOOL

## SEMESTRAL ASSESSMENT (1)

2013

Name : \_\_\_\_\_ Index No: \_\_\_\_\_ Class: P 3 \_\_\_\_\_

7 May 2013

SCIENCE

Attn: 1 h 15min

|                            |    |
|----------------------------|----|
| Section A                  | 36 |
| Section B                  | 24 |
| Your score out of 60 marks |    |
| Parent's signature         |    |

### SECTION A (18 X 2 marks)

For each question from 1 to 18, four options are given. One of them is the correct answer. Make your choice (1, 2, 3 or 4). Shade the correct oval on the Optical Answer Sheet.

1. Which one of the following characteristics is true of all living things?

- (1) They feed on animals.
- (2) They move about freely.
- (3) They reproduce by laying eggs.
- (4) They respond to changes around them.

2. Which of these objects are made of things that were once alive?

- A newspaper
- glass bottle
- leather belt
- wooden bench

- (1) A only
- (2) B only
- (3) A, C and D only
- (4) A, B, C and D



3. Sam carried out an experiment using seeds of the same type. Each was put in identical containers under a different set of conditions. The diagrams below show his observations in each set-up after 3 days.

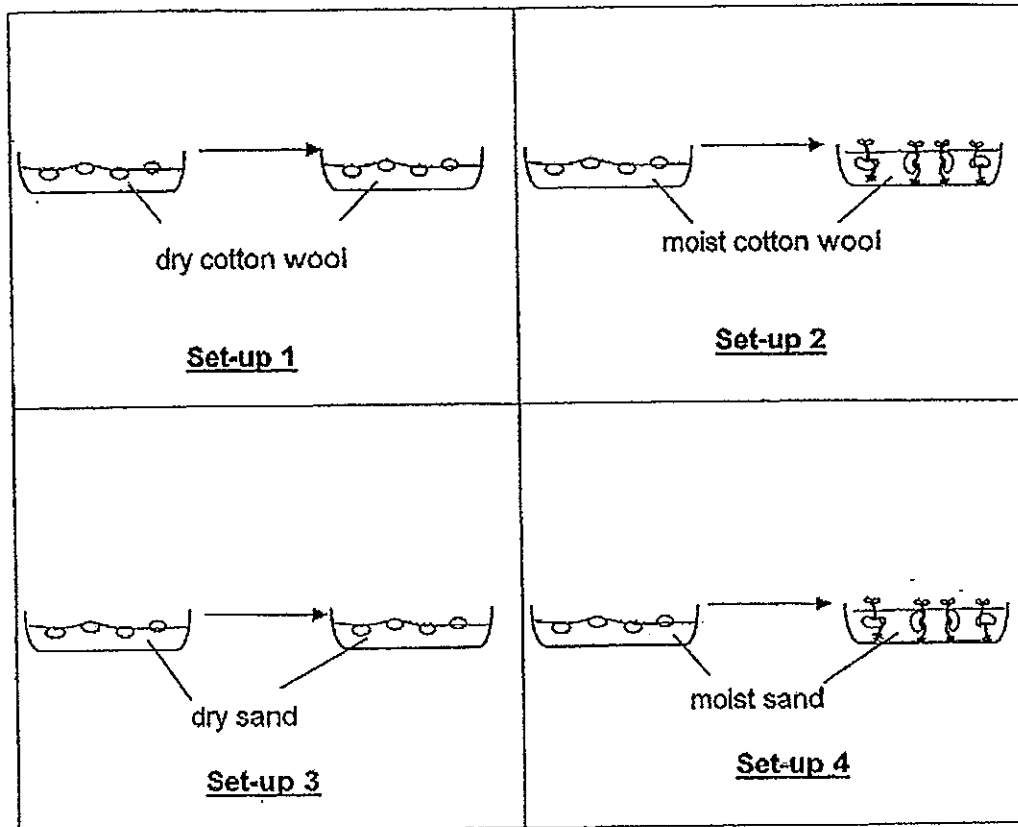

Based on the observation above, what can Sam conclude?

The seeds need \_\_\_\_\_ to germinate.

- (1) air
- (2) soil
- (3) water
- (4) cotton wool

4. Ali put a mouse in a tank. He covered it with a wire mesh as shown below.

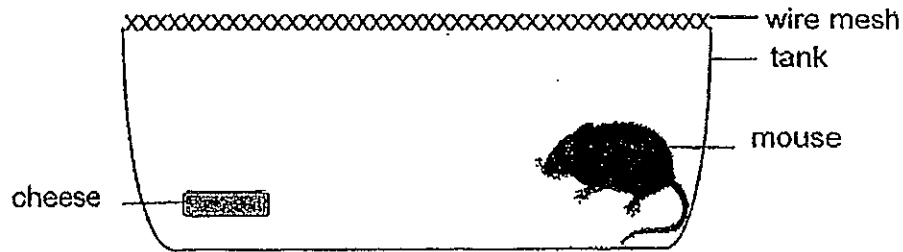

Ali placed the above set-up near the window. The mouse was only fed with cheese daily. After one week, it was observed to be dead.

Based on the above information, which of the following is most likely to be the reason for its death?

- (1) There was no water.
- (2) There was no sunlight.
- (3) There was not enough air in the tank.
- (4) There was not enough room for the mouse to move about.

5. Based on your observations of the following animals, which one of them is not an insect?

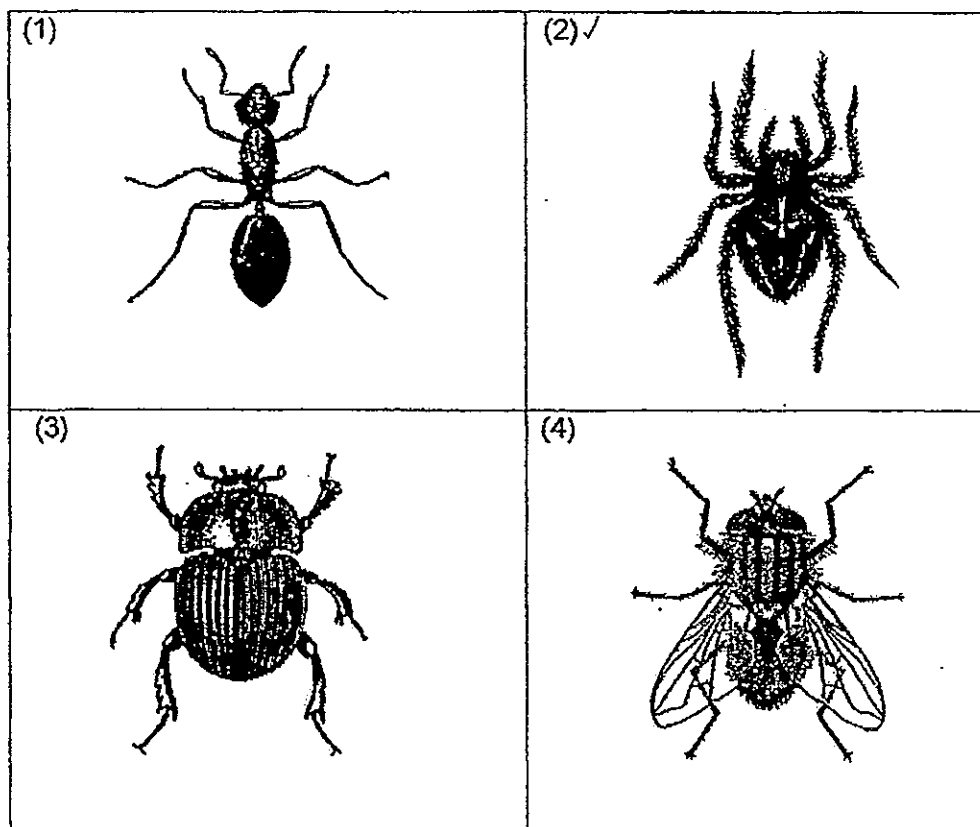

Based on the information below, answer questions 6 and 7.

Nine animals are classified into three groups as shown below.

| Animals    |         |          |
|------------|---------|----------|
| Group X    | Group Y | Group Z  |
| angelfish  | bat     | cat      |
| silverfish | duck    | deer     |
| clownfish  | penguin | platypus |

6. Which of these animals are classified wrongly?

- (1) bat and platypus
- (2) silverfish and bat
- (3) silverfish and penguin
- (4) penguin and platypus



7. Which of the following characteristics is true for all animals in Group Z?

- A They have hair.
- B They give birth to live young.
- C They feed their young with milk.

- (1) A only
- (2) B only
- (3) A and C only
- (4) A, B and C

8. The table below shows how some animals can be classified.

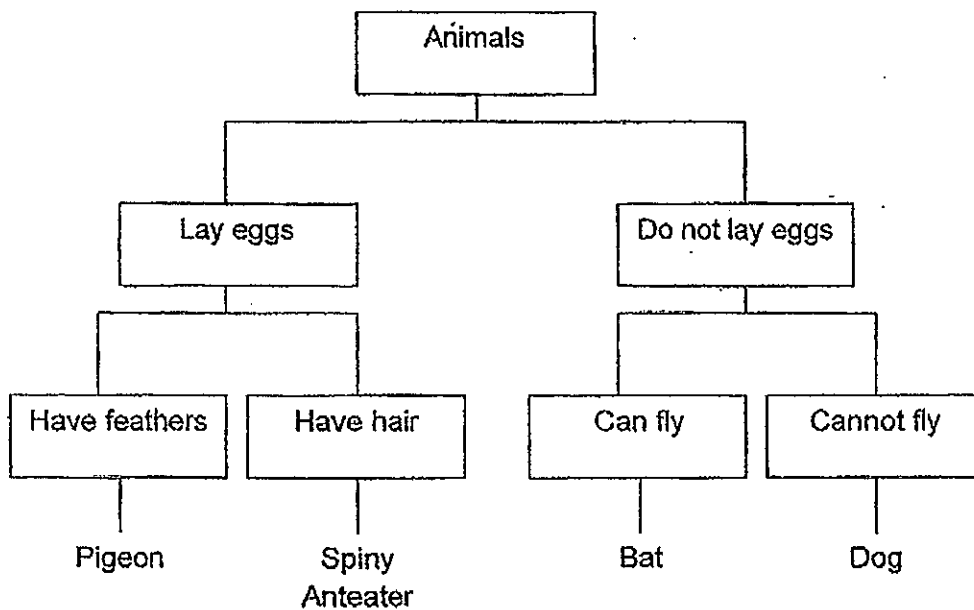

Based on the above classification chart, which one of the following statements is most possibly true?

- (1) A bat and a spiny anteater lay eggs.
- (2) A dog and a bat move in the same manner.
- (3) A bat and a dog give birth to its young alive.
- (4) A pigeon and a spiny anteater have the same body covering.

9. The flow chart below differentiates some living things.

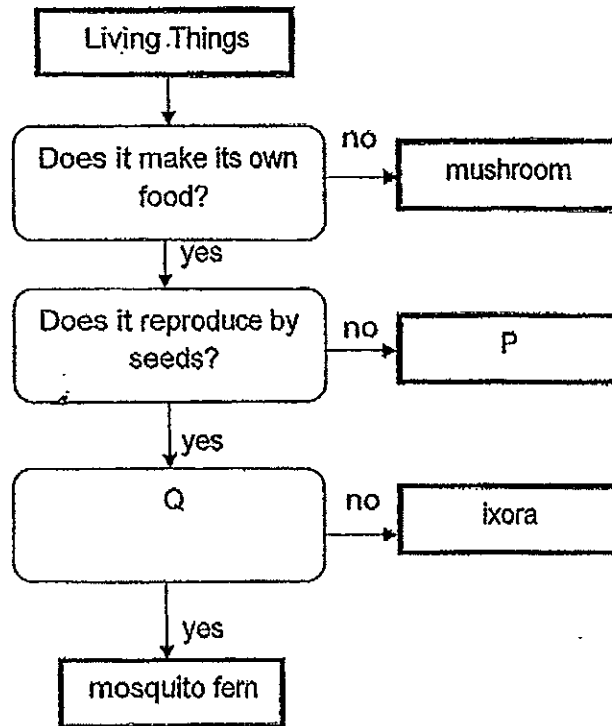

Which one of the following best represents P and Q respectively?

|     | P                | Question Q                              |
|-----|------------------|---|
| (1) | moss             | Does it have brightly-coloured flowers? |
| (2) | tree fern        | Does it have a strong stem?             |
| (3) | sword fern       | Does it grow in water?                  |
| (4) | bird's nest fern | Does it grow on land?                   |

10. The table below shows the characteristics of plants A, B, C and D. A tick (✓) in the box indicated the characteristic of the plant.

|                   | A | B | C | D |
|-------------------|---|---|---|---|
| It bears fruit.   | ✓ |   | ✓ | ✓ |
| It grows on land. |   | ✓ | ✓ |   |

Based on the information above, which of the following shows the correct classification of the plants A, B, C and D?

|     | Plants    |      |               |      |
|-----|-----------|------|---------------|------|
|     | Flowering |      | Non-flowering |      |
|     | Water     | Land | Water         | Land |
| (1) | A         | C, D |               | B    |
| (2) |           | B    | A             | C, D |
| (3) | D         | B    | A             | C    |
| (4) | A, D      | C    |               | B    |

11. Study the classification table below. Which one of the following has been grouped **incorrectly**?

|     | Group | Flowering plants  | Non-flowering plants  | Fungi   |
|-----|-------|---|---|---|
| (1) | P     | <ul style="list-style-type: none"> <li>• Lantana</li> <li>• Maize plant</li> </ul>      | <ul style="list-style-type: none"> <li>• pine</li> <li>• moss</li> </ul>            | <ul style="list-style-type: none"> <li>• Yeast</li> <li>• bracket fungus</li> </ul> |
| (2) | Q     | <ul style="list-style-type: none"> <li>• coconut palm</li> <li>• orchid</li> </ul>      | <ul style="list-style-type: none"> <li>• tree fern</li> <li>• sword fern</li> </ul> | <ul style="list-style-type: none"> <li>• mould</li> <li>• toadstool</li> </ul>      |
| (3) | R     | <ul style="list-style-type: none"> <li>• Maize plant</li> <li>• mimosa</li> </ul>       | <ul style="list-style-type: none"> <li>• pine</li> <li>• Lantana</li> </ul>         | <ul style="list-style-type: none"> <li>• mushroom</li> <li>• toadstool</li> </ul>   |
| (4) | S     | <ul style="list-style-type: none"> <li>• coconut palm</li> <li>• Maize plant</li> </ul> | <ul style="list-style-type: none"> <li>• pine</li> <li>• moss</li> </ul>            | <ul style="list-style-type: none"> <li>• Mould</li> <li>• bracket fungus</li> </ul> |

12. Ali found an organism shown below while hiking.



puffball

He described it as follows:

- A It grew on a rotting log.
- B It was white and round like a ball.
- C When pressed, some spores escaped.

Which of the above characteristic confirmed that it is a fungi?

- (1) A only
- (2) A and B only
- (3) A and C only
- (4) A, B and C





13. David placed three pieces of bread from the same loaf on a table. He arranged the bread according to the amount of mould found on them after a week.

Which one of the following is the most possible arrangement in order from the one with the most mould?

|     | Most mould  | —————→        | Least mould   |
|-----|-------------|---------------|---------------|
| (1) | fresh bread | moist bread   | toasted bread |
| (2) | fresh bread | toasted bread | moist bread   |
| (3) | moist bread | fresh bread   | toasted bread |
| (4) | moist bread | toasted bread | fresh bread   |

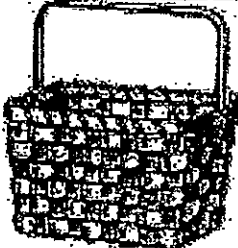
Based on your observations, answer questions 14 and 15.

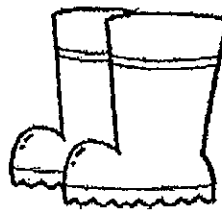
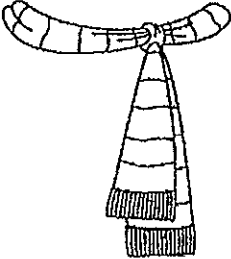
Six objects are classified into three groups as shown below.

| Group A  | Group B  | Group C  |
|--|--|--|
| <br>paper basket  | <br>Woolen hat  | <br>metal frying pan |
| <br>rubber boots | <br>silk scarf | <br>glass vase     |

14. Objects from Group C are made from \_\_\_\_\_.

- (1) plants only
- (2) animals only
- (3) both animals and plants
- (4) things found in the ground

15. The objects from Group A and B can be grouped together.  
In what way are they similar?

- (1) The objects are waterproof.
- (2) The objects can float in water.
- (3) They are made of things from the ground.
- (4) They are made of things that were once alive.

16. Sally investigated the properties of the objects below.

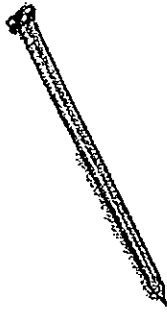

iron nail



paper clip

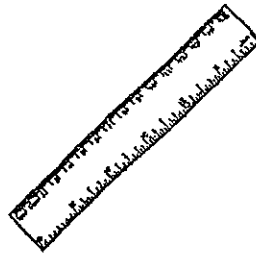

metal ruler

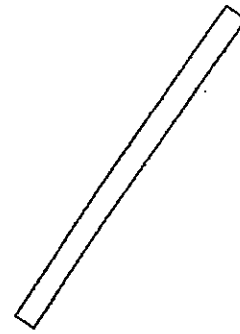

plastic drinking  
straw

She made the following observations about the properties of one of the objects above.

- It can be bent easily.
- It does not absorb water.
- It can be cut easily with a pair of scissors.

Which one of the following objects did Sally observe?

- (1) iron nail
- (2) paper clip
- (3) metal ruler
- (4) plastic drinking straw

17. Tina wanted to test the hardness of 4 materials of the same size, P, Q, R and S. She used a nail to scratch on each material.

Then she recorded her observations in the table below

| Material | Observation                |
|----------|----------------------------|
| P        | a cut through material     |
| Q        | no scratches on surface    |
| R        | light scratches on surface |
| S        | deep scratches on surface  |

Which of the following shows the correct order of the materials from the hardest to the softest?

- (1) P, Q, R, S
- (2) P, S, R, Q
- (3) Q, R, S, P
- (4) S, R, Q, P

18. Sam wanted to find out the strength of 4 different types of paper, W, X, Y and Z of the same size. He hung each piece of paper, one at a time, using the following set-up as shown below.

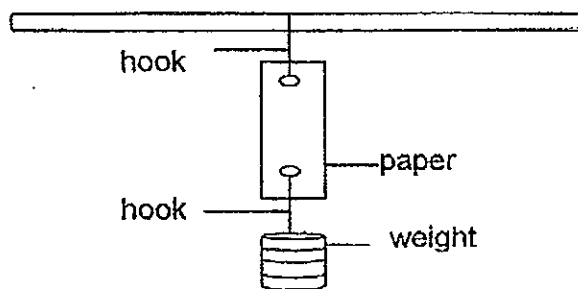

Sam added one weight at a time to the hook until the paper started to tear and recorded his results as shown in the graph below.

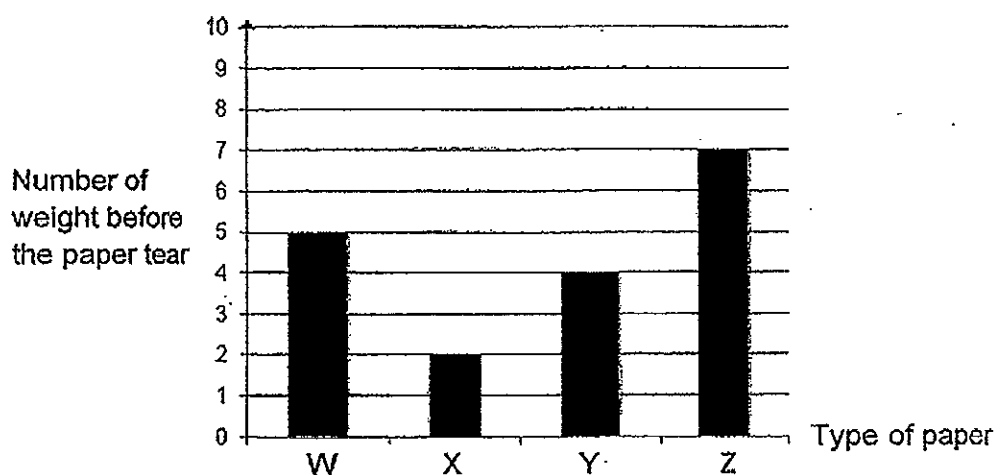

Based on the information above, which of the following statements are correct?

- A Y is stronger than Z.
- B Z is the strongest paper.
- C W is stronger than X and Y.
- D X is stronger than W and Y.

- (1) B only
- (2) B and C only
- (3) A and D only
- (4) A and C only



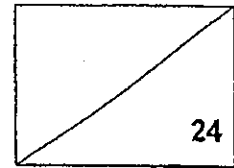

Name : \_\_\_\_\_ Index No: \_\_\_\_\_ Class: Primary 3 \_\_\_\_\_

**SECTION B (24 marks)**

For questions 19 to 30, write your answers clearly in the spaces provided. The number of marks available is shown in the brackets [ ] at the end of each question or part question.

19. The leaves of a mimosa plant close when touched.

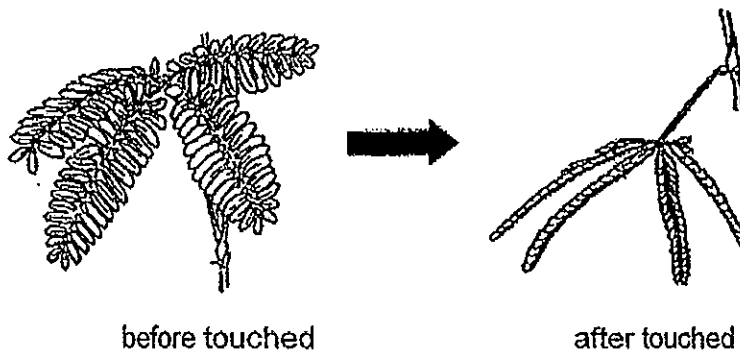

(a) Based on the above observation, state a characteristic of living thing which is shown by the mimosa plant. [1]

---

---

(b) After one month, the leaves on the mimosa plant increased in size. What characteristic of living thing does this observation show? [1]

---

---

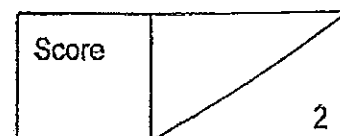

20. David put a rabbit in each containers, A, B and C, as shown in the diagram below. He placed a carrot in all the containers and a bowl of water in container B and C only.

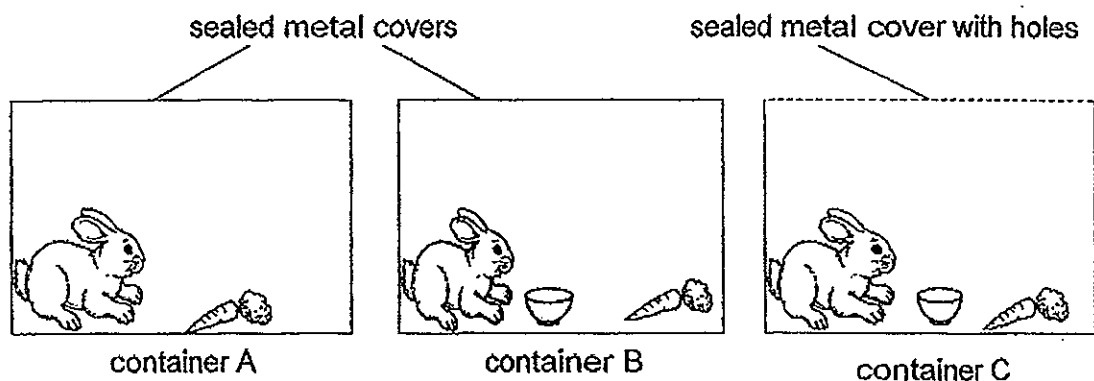

- (a) Based on the information above, answer the following questions: [1]  
In which container would the rabbit live the longest? Explain your answer.

| Container | Explanation |
|-----------|-------------|
| _____     |             |

- (b) What do you think will happen to the rabbits if all the containers above were filled with water up to the brim? Give a reason for your answer. [1]

---

|       |   |
|-------|---|
| Score | 2 |
|-------|---|

21. Some scientists discovered an animal X. They observed that the animal X bears the following characteristics:

- It lays eggs.
- It lives in water.
- It feeds its young with milk.
- It has a body covering of hair.

(a) Based on the information above, which animal group would the animal X most likely belong to? [1]

---

(b) Explain your answer in (a) clearly. [1]

---

---

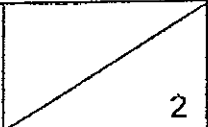
|       |   |
|-------|---|
| Score |  |
|-------|---|

22. The flow chart below shows how the animals P, Q and R are classified.

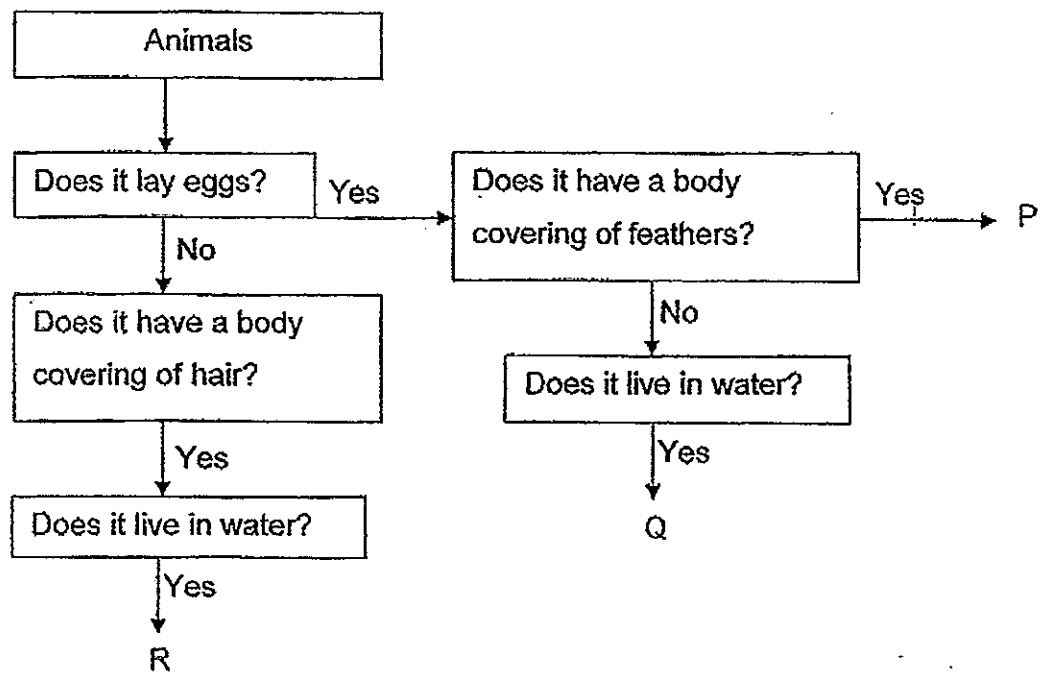

[1]

(a) Based on the information above, which animal, P, Q or R, is a bird?  
State a reason for your answer.

| Animal | Reason      |
|--------|-------------|
| _____  | <hr/> <hr/> |

Give an example of each of the following:

(b)

[2]

Animal R: \_\_\_\_\_

Animal Q: \_\_\_\_\_

|       |  |
|-------|--|
| Score |  |
|-------|--|

23. The diagram below shows a banana plant.

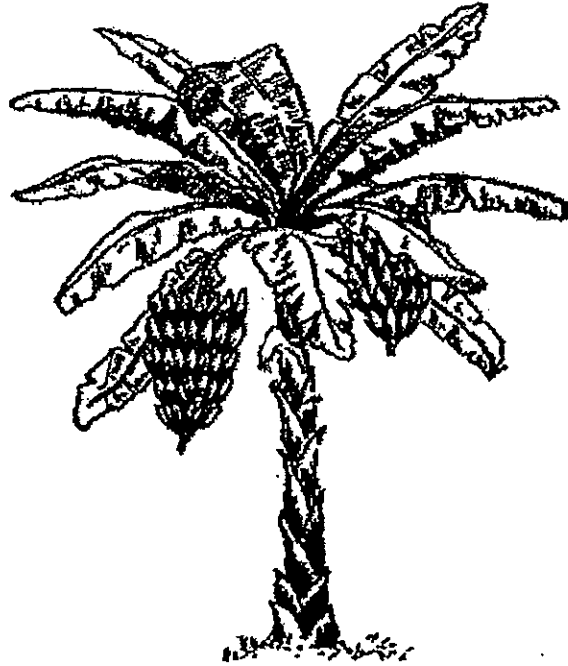

Banana tree

The following are the characteristics of the banana tree. Put a tick (✓) in the correct box below.

[2]

|     | Characteristic                            | True | False | Not possible to tell |
|-----|---|------|-------|----------------------|
| (a) | It does not need support to grow upright. |      |       |                      |
| (b) | It is a water plant.                      |      |       |                      |
| (c) | It makes its own food.                    |      |       |                      |
| (d) | It is a flowering plant.                  |      |       |                      |

|       |   |
|-------|---|
| Score | 2 |
|-------|---|

24. The pictures below shows 2 different plants, A and B, not drawn to scale.

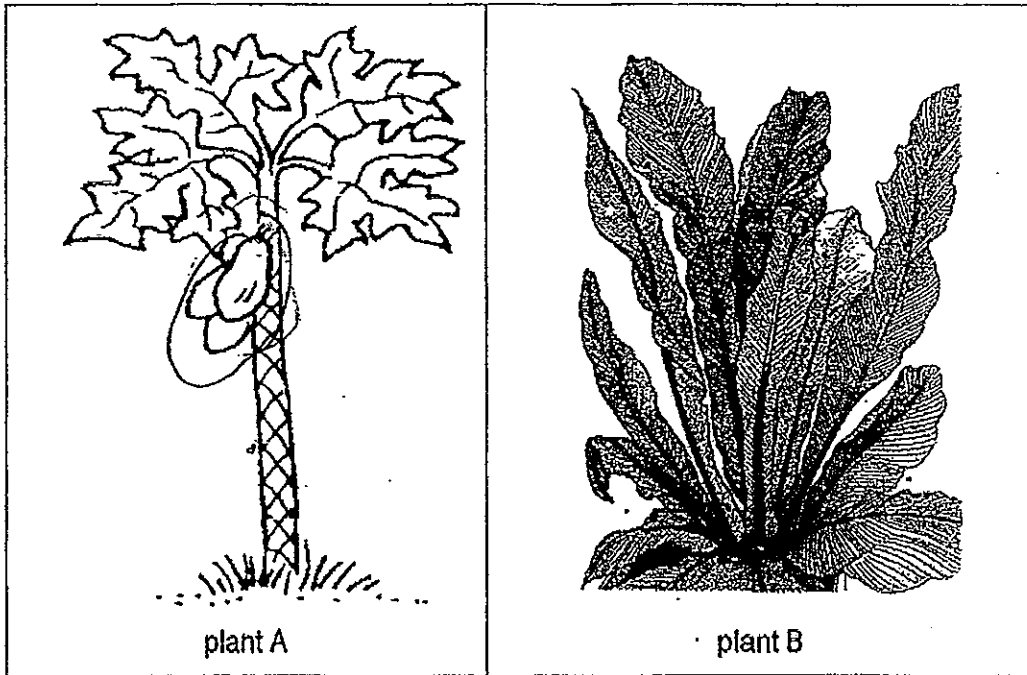

Based on your **observation** of the plants above, state one similarity and one difference between the plants. [Do not mention the size and shape] [2]

|            |                   |
|------------|-------------------|
| Similarity | <hr/> <hr/> <hr/> |
| Difference | <hr/> <hr/> <hr/> |

|       |   |
|-------|---|
| Score | 2 |
|-------|---|

25. Sally observed some plants and classified them in the table below.

| Group X                                   | Group Y                            |
|---|------------------------------------|
| rose plant<br>tulip plant<br>orchid plant | moss<br>bamboo<br>bird's nest fern |

(a) Name the plant which Sally classified incorrectly. Give a reason for your answer. [1]

| Plant | Reason |
|-------|--------|
|       |        |
|       |        |
|       |        |
|       |        |

(b) Name another plant that can be classified under group Y.

\_\_\_\_\_

|       |   |
|-------|---|
| Score | 2 |
|-------|---|

26. Tim had a slice of raw fish for dinner and it caused him to suffer from a stomachache. The doctor said it was due to a type of organism present in the raw fish.

(a) What group of organisms is most likely to be responsible for Tim's <sup>stomachache</sup> stomachache? [1]

---

(b) State one way in which the group of organisms mentioned in (a) can also be useful to man. [1]

---

---

27. The pictures below show a fern and a mushroom, not drawn to scale.



fern

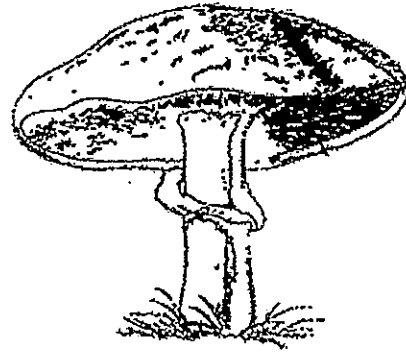

mushroom

(a) In the diagram above, label with an "X" to show the part of the mushroom where spores are found. [1]

(b) Can fern make its own food? Give a reason for your answer. [1]

---

---

|       |   |
|-------|---|
| Score |   |
|       | 4 |



28. (a) The picture below shows a nail clipper which is made of a type of material.

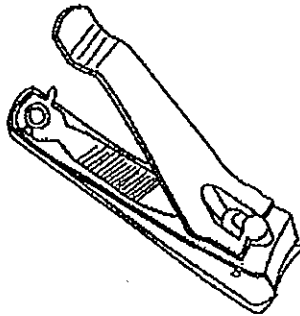

Name the material that is used to make the nail clipper. State two properties of the material that is taken into consideration to make the nail clipper.

[1]

| Material | Properties  |
|----------|-------------|
| <hr/>    | <hr/> <hr/> |

|       |            |
|-------|------------|
| Score | <hr/><br>1 |
|-------|------------|

29. The picture below shows the various positions of objects A, B, C and D when they were put in a tank of water.

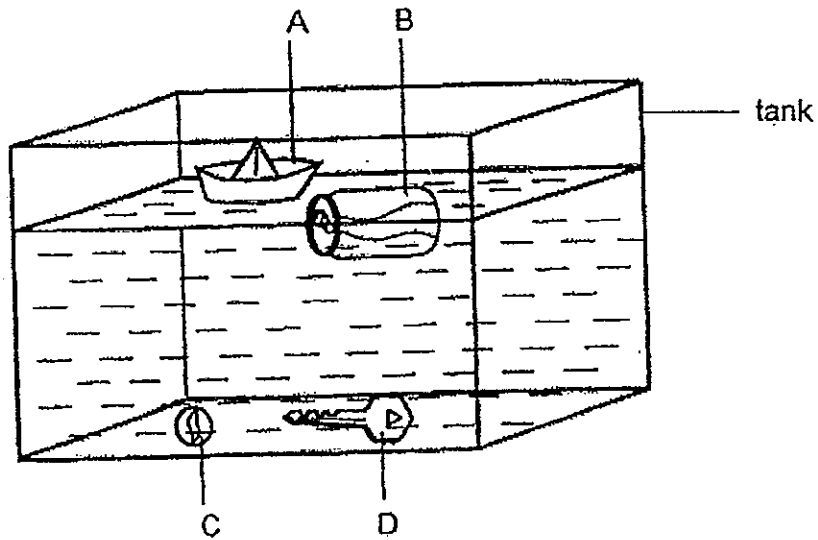

Based on your observations, complete the classification with objects A, B, C and D. [2]

| Objects |      |
|---------|------|
| Float   | Sink |
|         |      |

|       |   |
|-------|---|
| Score | 2 |
|-------|---|

30. Mr Lee is a shoe manufacturer. He wants to select the best material that will keep the feet dry during rainy days. He placed an identical size of material A, B and C over each container respectively. Next, 100 ml of water was poured over each material. The amount of water collected in each container after 5 minutes is shown in the diagrams below.

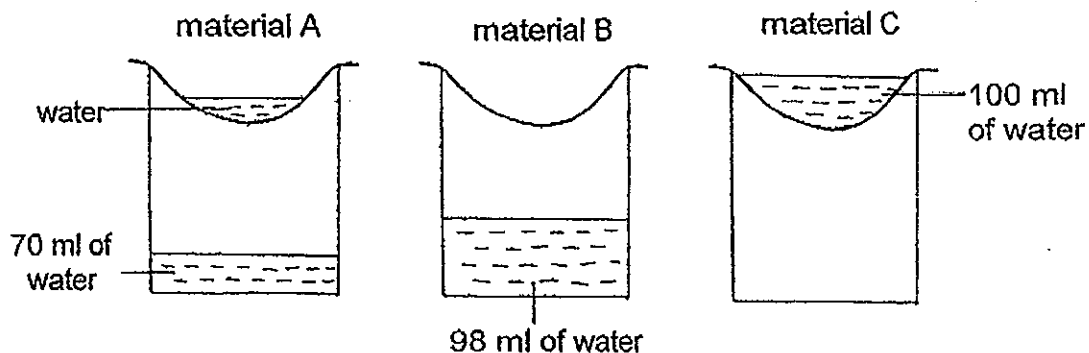

Based on the information above, answer the following questions:

- (a) Which materials, A, B or C, should Mr Lee choose to make the shoes? Give a reason for your answer. [1]

| Material | Reason |
|----------|--------|
|          |        |
|          |        |
|          |        |

- (b) Which material, A, B, or C, is most suitable to make into a coffee filter bag to separate the coffee from the coffee powder most effectively. Explain your answer clearly. [1]

| Material | Explanation |
|----------|-------------|
|          |             |
|          |             |
|          |             |

- END OF PAPER -

|       |   |
|-------|---|
| Score | 2 |
|-------|---|

# ANSWER SHEET

**EXAM PAPER 2013**

**SCHOOL : RAFFLES GIRLS' PRIMARY SCHOOL**

**SUBJECT : PRIMARY 3 SCIENCE**

**TERM : SA1**

---

|    |    |    |    |    |    |    |    |    |     |     |     |     |     |     |     |     |
|----|----|----|----|----|----|----|----|----|-----|-----|-----|-----|-----|-----|-----|-----|
| Q1 | Q2 | Q3 | Q4 | Q5 | Q6 | Q7 | Q8 | Q9 | Q10 | Q11 | Q12 | Q13 | Q14 | Q15 | Q16 | Q17 |
| 4  | 3  | 3  | 1  | 2  | 2  | 3  | 3  | 3  | 4   | 3   | 3   | 3   | 4   | 4   | 4   | 3   |

|     |
|-----|
| Q18 |
| 2   |

Section B

Q19

- a) Living things respond to changes around them
- b) Living things can grow

Q20

a)

| Container | Explanation  |
|-----------|--|
| C         | The rabbit has enough air, water and food to survive |

b) The rabbit will die as they have no air

Q21

- a) Mammals
- b) Animal X has hair and it feeds its young with milk

Q22

a)

| Animal | Reason  |
|--------|---|
| P      | A bird lays eggs and has feather as body covering |

- b) Animal R: Dolphin  
 Animal Q: Platypus

Q23

|     | Characteristic                           | True | False | Not possible to tell |
|-----|--|------|-------|----------------------|
| (a) | It does not need support to grow upright |      |       | ✓                    |
| (b) | It is a water plant                      |      | ✓     |                      |
| (c) | It makes its own food                    | ✓    |       |                      |
| (d) | It is a flowering plant                  | ✓    |       |                      |

Q24

|            |  |
|------------|--|
| Similarity | They both have leaves                                  |
| Difference | Plant A bears fruit while plant B does not bear fruits |

Q25

a)

| Plant  | Reason                      |
|--------|-----------------------------|
| Bamboo | Bamboo is a flowering plant |

b) Sword fern

Q26

- a) Bacteria  
 b) It can help your food be digested

Q27

a)

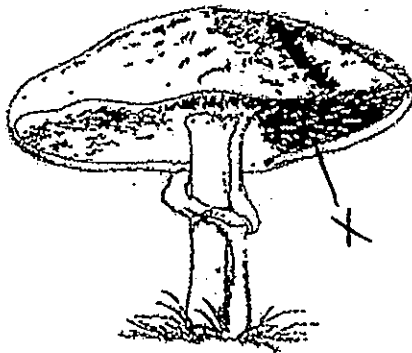

mushroom

b) Yes, it can make its own food in the presence of light

Q28

| Material | Properties            |
|----------|-----------------------|
| Steel    | It is hard and strong |

Q29

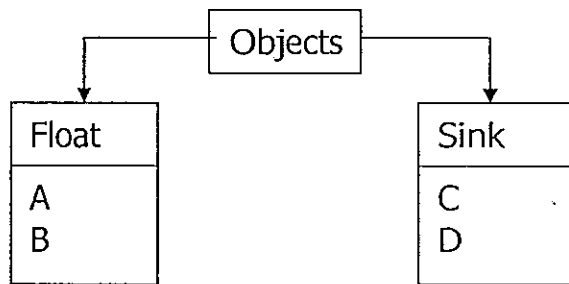

Q30

a)

| Material | Reason           |
|----------|------------------|
| C        | It is waterproof |

b)

| Material | Reason  |
|----------|---|
| B        | Material B allows most of the water to pass through |





**Rosyth School**  
**Semestral Examination 1 for 2013**  
**SCIENCE**  
**Primary 3**

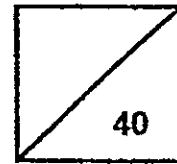

Name: \_\_\_\_\_

Total  
Marks:

Class: Pr 3 \_\_\_\_\_ Register No. \_\_\_\_\_ Duration: 1 h 30 min

Date: 15 May 2013 Parent's Signature: \_\_\_\_\_

---

## **BOOKLET A**

### **Instructions to Pupils:**

- 1. Do not open the booklets until you are told to do so.**
- 2. Follow all instructions carefully.**
- 3. This paper consists of 2 booklets, Booklet A and Booklet B.**
- 4. For questions 1 to 20 in Booklet A, shade the correct ovals on the Optical Answer Sheet (OAS) provided using a 2B pencil.**
- 5. For questions 21 to 32, give your answers in the spaces given in Booklet B.**

**\* This booklet consists of 13 pages.**

**This paper is not to be reproduced in part or whole without the permission of the Principal.**



**Part I (40 MARKS)**

For each question from 1 to 20, four options are given. One of them is the correct answer. Make your choice (1, 2, 3 or 4) and shade the correct oval (1, 2, 3 or 4) on the Optical Answer Sheet (OAS).

1. Look at the classification chart below.

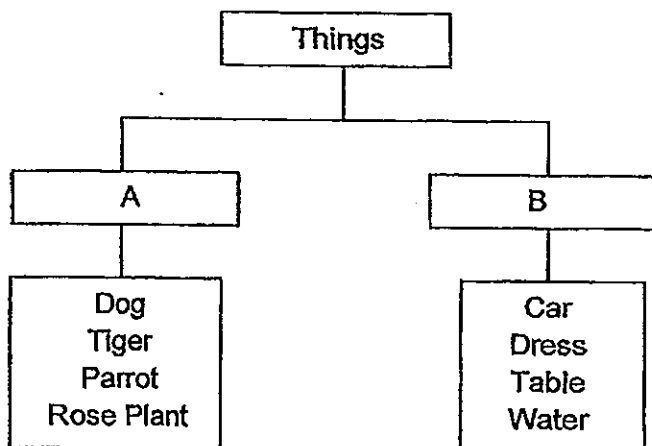

Which of the following are the correct headings for A and B?

|     | A                    | B                       |
|-----|----------------------|-------------------------|
| (1) | Living Things        | Non-Living Things       |
| (2) | Non-Living Things    | Living Things           |
| (3) | Things found on land | Things found in the sky |
| (4) | Things that can move | Things that cannot move |

2. Which one of the following statements about fungi is true?

- (1) All fungi are edible.
- (2) Fungi make their own food.
- (3) Fungi feed on plants and animals.
- (4) Fungi reproduce by producing seeds.

3. Which of the following statements are characteristics of all living things?

- A: They grow.
- B: They reproduce.
- C: They make their own food.
- D: They move by themselves.

- (1) A, B and C only
- (2) A, B and D only
- (3) B, C and D only
- (4) A, C and D only

4. Alice compared a bird and an insect. Which of the following characteristics make a bird different from an insect?

- A: It lays eggs.
- B: It has wings.
- C: It has a beak.
- D: It has feathers.

- (1) A and B only
- (2) C and D only
- (3) A, C and D only
- (4) B, C and D only

5. Study the classification table below.

| Group X | Group Y | Group Z |
|---------|---------|---------|
| Fishes  | Birds   | Mammals |

How are the animals in Group X, Y and Z classified?

- (1) According to their movement
- (2) According to their outer covering
- (3) According to how they reproduce
- (4) According to their number of body parts

6. Study the flow chart below.

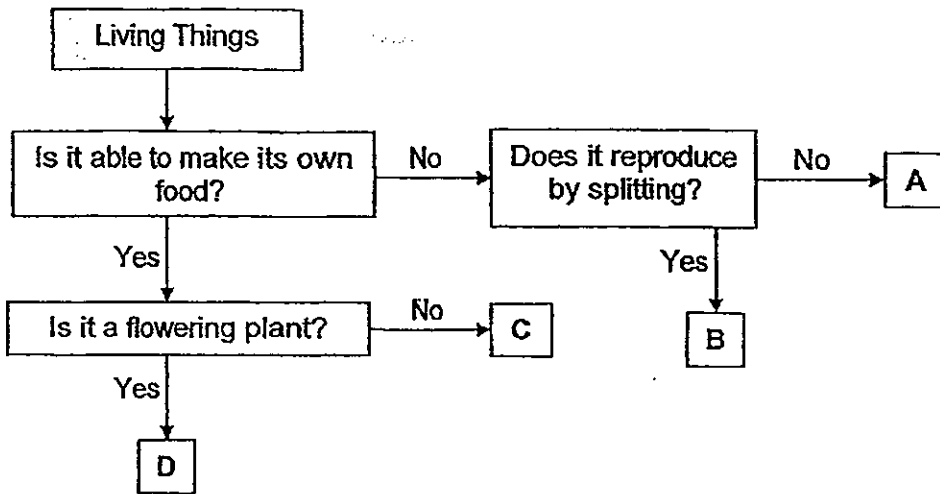

Which letter (A, B, C or D) best represents the living thing as shown below?



- (1) A
- (3) C

- (2) B
- (4) D

7. Study the flow chart below.

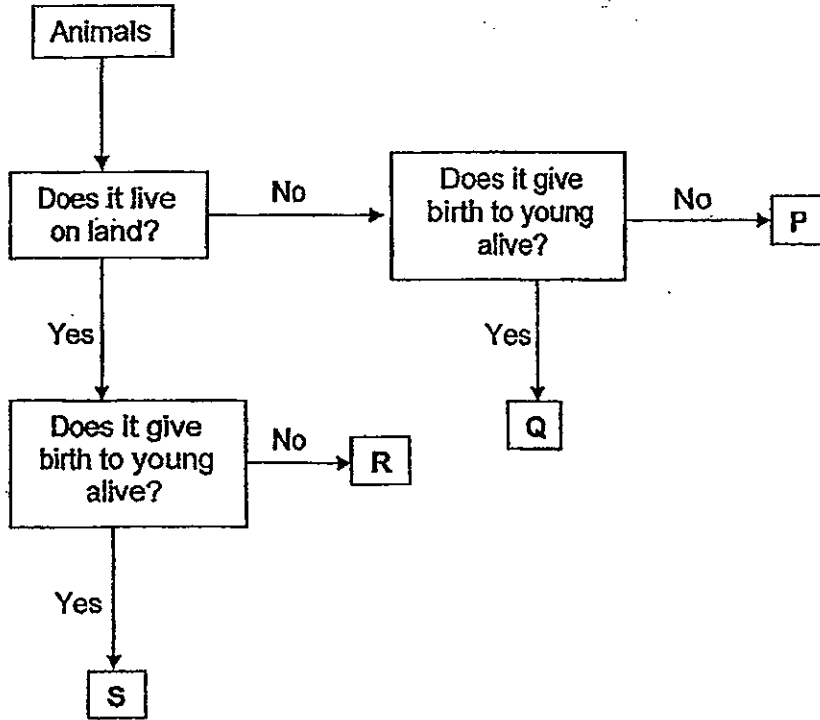

Which letter (P, Q, R or S) best represents the animal shown below?



Mosquito

- (1) P
- (3) R

- (2) Q
- (4) S

8. Study the diagrams below.

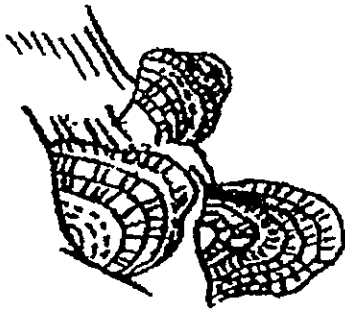

Bracket fungi



Mimosa plant

The bracket fungi and mimosa plant have similar characteristics. How are they similar?

- (1) Both of them feed on other plants.
- (2) Both of them reproduce by spores.
- (3) Both of them need food to survive.
- (4) Both of them are non-flowering plants.

9. Lily found four animals (P, Q, R and S) and took care of them for a few months. The table below describes what she observed during that period. A tick (✓) represents a characteristic that the animal has.

|                  | Animal P | Animal Q | Animal R | Animal S |
|------------------|----------|----------|----------|----------|
| Can fly          | x        | ✓        | x        | x        |
| Lay eggs         | ✓        | ✓        | x        | ✓        |
| More than 2 legs | x        | x        | ✓        | ✓        |

Which one of the following animals is most likely to be a fish?

- (1) Animal P
- (2) Animal Q
- (3) Animal R
- (4) Animal S

10. John carried out an experiment with an equal number of fish in the set-ups as shown below. Each set-up was prepared under different conditions. In which set-up, A, B, C or D would the fish most likely die after one week?

(1) Set-up A

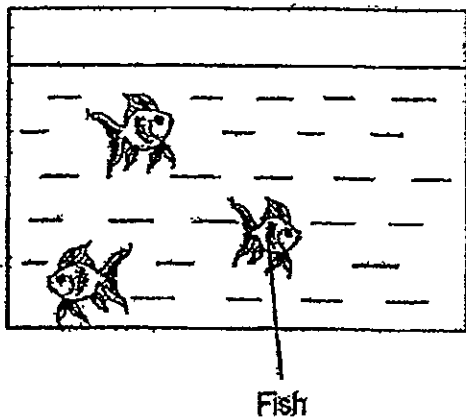

(2) Set-up B

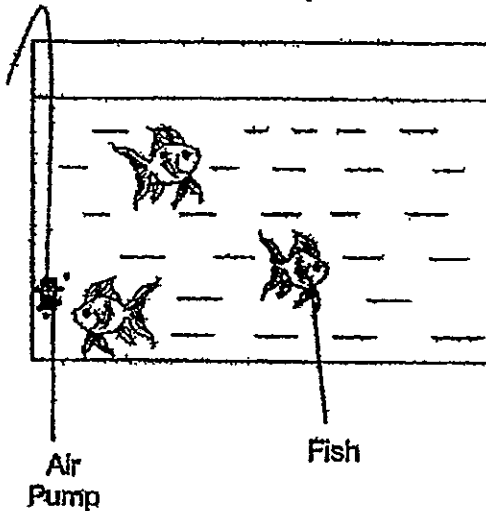

(3) Set-up C

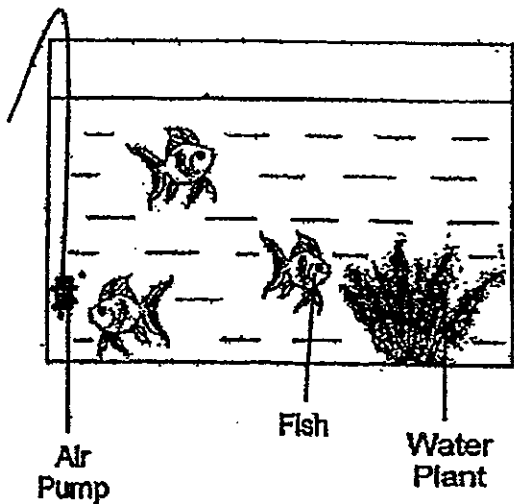

(4) Set-up D

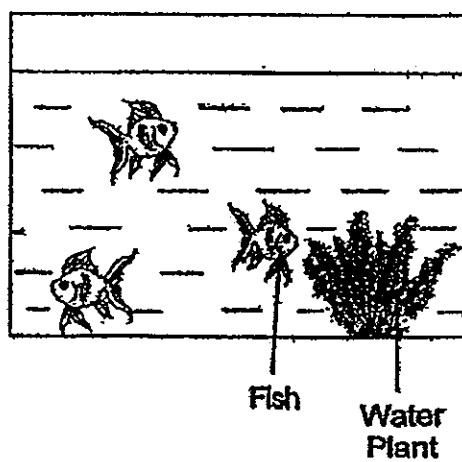

11. Mary described the properties of a material as shown below.

It is light.  
 It is waterproof.  
 It can be flexible or stiff.

Which of the following is most likely to be the material she has described?

- |            |             |
|------------|-------------|
| (1) Paper  | (2) Wood    |
| (3) Fabric | (4) Plastic |

12. The diagram below shows a tricycle. It is made of different materials.

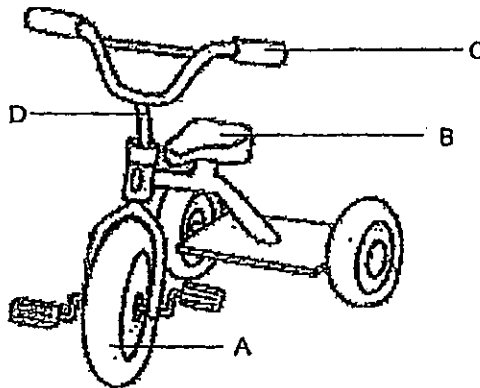

Which of the following best explain why the materials are chosen for parts A, B, C and D of the tricycle?

| Part | Material | Reason                       |
|------|----------|------------------------------|
| A    | rubber   | It is strong and waterproof. |
| B    | plastic  | It is hard and strong.       |
| C    | rubber   | It is stiff.                 |
| D    | metal    | It is strong and flexible.   |

- |                     |                     |
|---------------------|---------------------|
| (1) A and B only    | (2) C and D only    |
| (3) A, B and C only | (4) A, B and D only |

13. The classification diagram below shows how some objects are grouped into Group A and Group B.

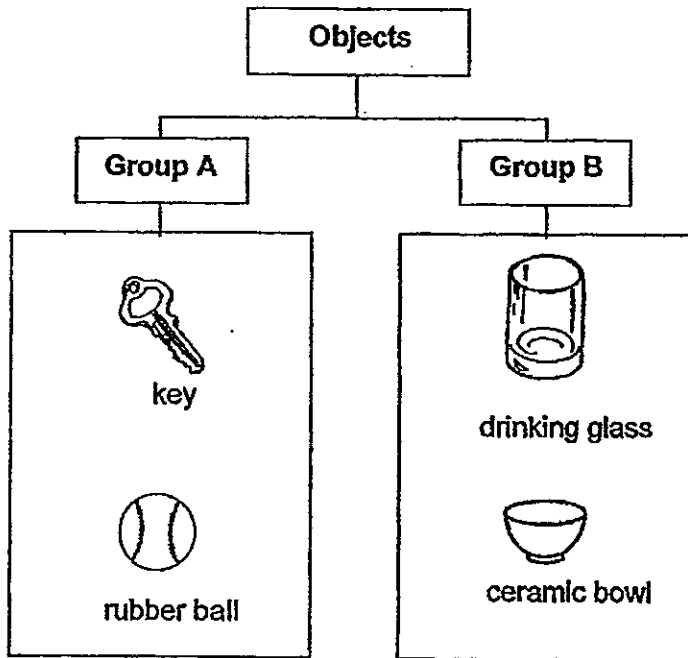

Which of the following headings best describe the materials used to make the objects in Group A and Group B?

|     | Group A        | Group B    |
|-----|----------------|------------|
| (1) | Soft           | Hard       |
| (2) | Flexible       | Stiff      |
| (3) | Non-breakable  | Breakable  |
| (4) | Non-waterproof | Waterproof |



14. Henry wanted to make a pair of spectacles with glass lens. His father advised him to make the spectacles with plastic lens instead of glass lens. In what way is plastic lens better than glass lens for making Henry's spectacles?

- (1) Plastic is waterproof.
- (2) Plastic can be bent easily.
- (3) Plastic does not break easily.
- (4) Plastic does not scratch easily.

15. Weiling did a scratch test with four materials. She used each material to scratch one another and recorded her observations in the table below.

| Materials | Observations                               |
|-----------|--|
| A         | Made a scratch mark on D only              |
| B         | Made a scratch mark on A and D             |
| C         | Made a scratch mark on A, B and D          |
| D         | Did not make a scratch mark on any objects |

Based on the table, which of the following shows the correct order of the hardness of the materials, starting from the hardest material?

- (1) A, B, C, D
- (2) C, B, A, D
- (3) D, C, B, A
- (4) D, A, B, C

16. Alice has four objects: a plastic ruler, a glass cup, a wooden peg and a towel.

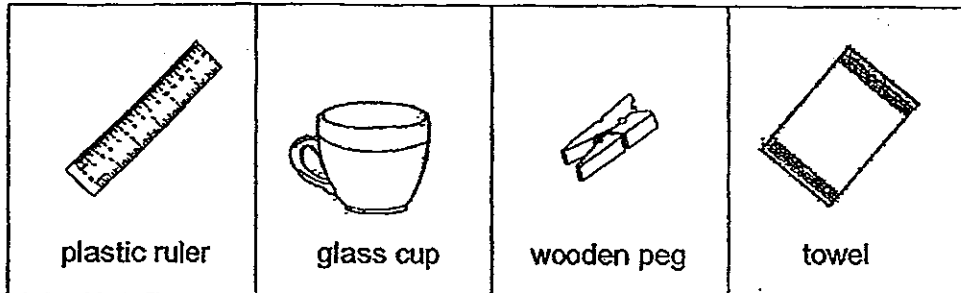

She used the flowchart shown below to sort the four objects into four boxes, A, B, C and D.

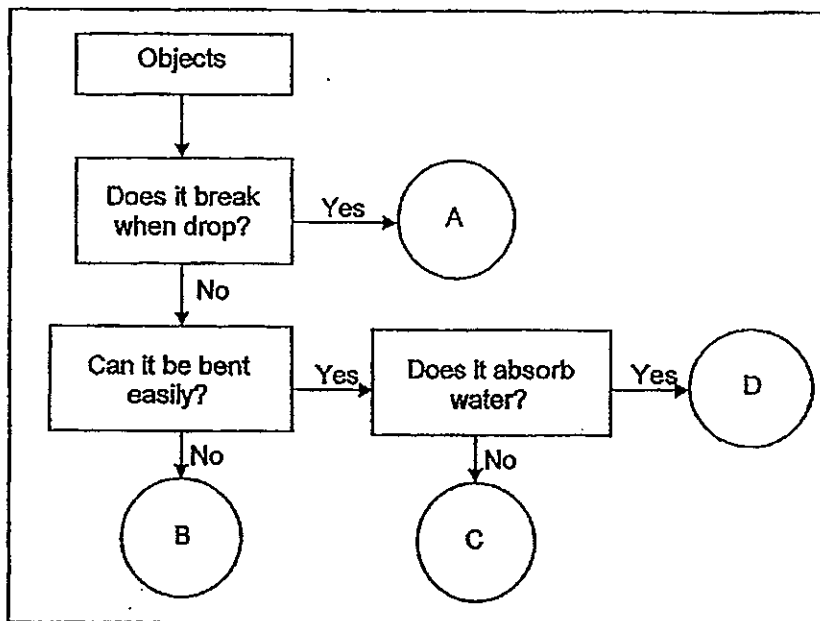

Which of the following best shows the object she placed in each of the four boxes A, B, C and D?

|     | A             | B          | C             | D             |
|-----|---------------|------------|---------------|---------------|
| (1) | plastic ruler | wooden peg | towel         | glass cup     |
| (2) | plastic ruler | towel      | glass cup     | wooden peg    |
| (3) | glass cup     | towel      | wooden peg    | plastic ruler |
| (4) | glass cup     | wooden peg | plastic ruler | towel         |

17. A magnet was brought near four containers made of four different kinds of materials as shown in the diagram below.

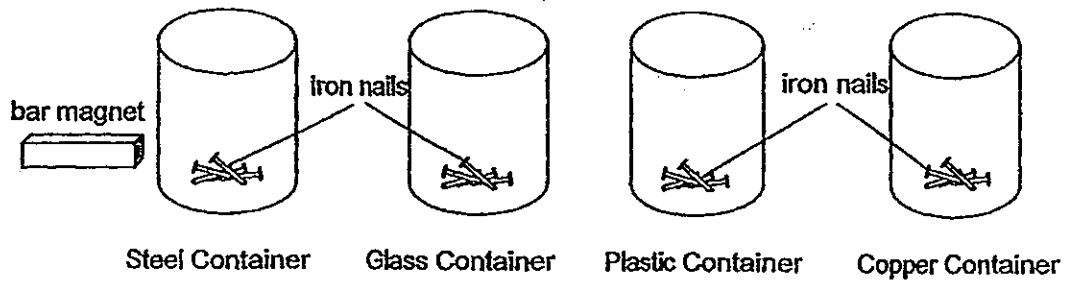

In which container would the iron nails not be attracted to the magnet?

- (1) Steel Container                      (2) Glass Container  
(3) Plastic Container                    (4) Copper Container
18. Sammy held a strong magnet over a container of gold coins, cotton balls, paper clips and marbles.

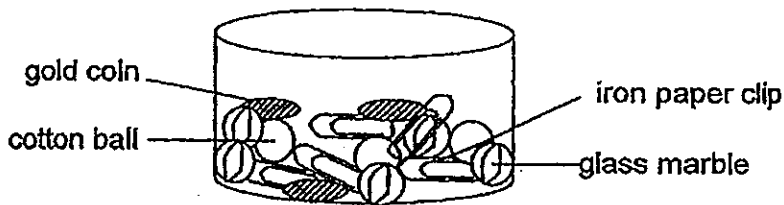

Which of the following objects would be attracted to the magnet?

- (1) coins only                              (2) paper clips only  
(3) marbles and cotton balls only      (4) paper clips and coins only

19. Amy and Bernard were able to use a strip of metal to hold a piece of paper against Whiteboard A. However, Cindy and Darren were not able to use the same strip of metal to hold the piece of paper against Whiteboard B.

Amy, Bernard, Cindy and Darren each made a statement about their observations.

- Amy : The strip of metal is a magnet.  
Bernard : The paper is a non-magnetic material.  
Cindy : Whiteboard A is made of magnetic material.  
Darren : Whiteboard B is made of non-magnetic material.

Whose statements are correct?

- (1) Amy, Cindy and Darren only  
(2) Amy, Bernard and Darren only  
(3) Bernard, Cindy and Darren only  
(4) Amy, Bernard, Cindy and Darren

20. Dave has three bar magnets as shown below.

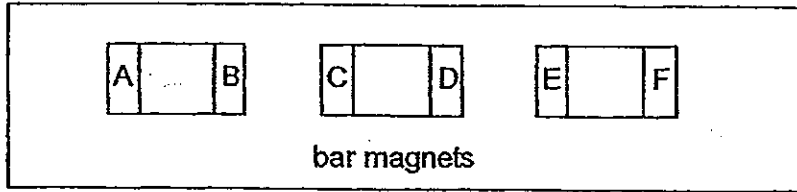

He puts two of them close to each other each time and notes his observations as shown below.

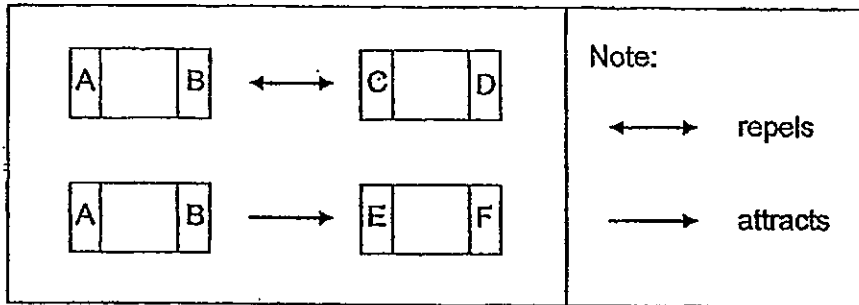

Which of the following would most likely happen when Dave tries to arrange the three magnets together?

(1)

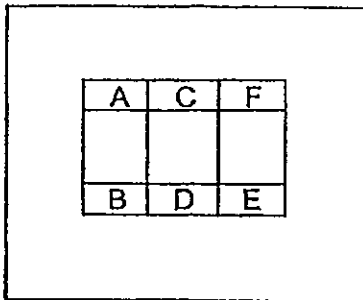

(2)

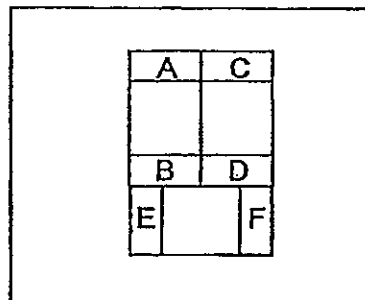

(3)

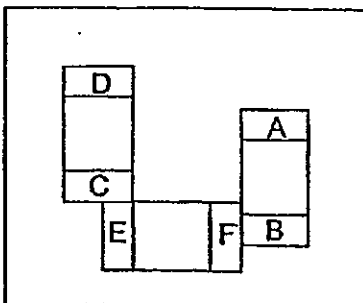

(4)

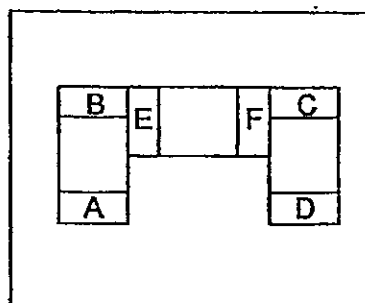

**End of Part I**



Rosyth School  
Semestral Examination 1 for 2013  
**SCIENCE**  
Primary 3

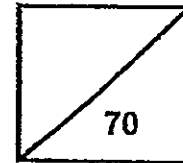

Name: \_\_\_\_\_

Total  
Marks:

Class: Pr 3 \_\_\_\_\_ Register No. \_\_\_\_\_ Duration: 1 h 30 min

Date: 15 May 2013 Parent's Signature: \_\_\_\_\_

---

## BOOKLET B

Instructions to Pupils:

1. For questions 21 to 32, give your answers in the spaces given in this Booklet B.

|           | Maximum  | Marks Obtained |
|-----------|----------|----------------|
| Booklet A | 40 marks |                |
| Booklet B | 30 marks |                |
| Total     | 70 marks |                |

\* This booklet consists of 12 pages.

This paper is not to be reproduced in part or whole without the permission of the Principal.

**Part II (30 MARKS)**

For questions 21 to 32, write your answers in this booklet.

21. Yijie bought a chick from a chicken farm. He measured the growth of the chick over 6 weeks and recorded the height of the chick in a table as shown below.

| Time   | Height (cm) |
|--------|-------------|
| Week 1 | 7           |
| Week 2 | 8           |
| Week 3 | 10          |
| Week 4 | 12          |
| Week 5 | 15          |
| Week 6 | 15          |

- (a) From the table above, what do you observe about the height of the chick from Week 1 to Week 6? (1m)

---



---

- (b) What is the characteristic of living things observed from Week 1 to Week 4? (1m)

---



---

22. Yifang has four hibiscus plants, E, F, G and H. She placed the plants under different conditions as shown in the table below.

| Plant | Conditions |          |       |
|-------|------------|----------|-------|
|       | Air        | Sunlight | Water |
| E     | √          |          | √     |
| F     | √          |          |       |
| G     | √          | √        |       |
| H     | √          | √        | √     |

- (a) Which one (E, F, G or H) will survive the longest? Give a reason for your answer. (1m)

---



---

Question 22 continues on page 2

- (b) Yifang placed the pot of plant in a box with a tiny opening as shown below. It was placed near a lamp.

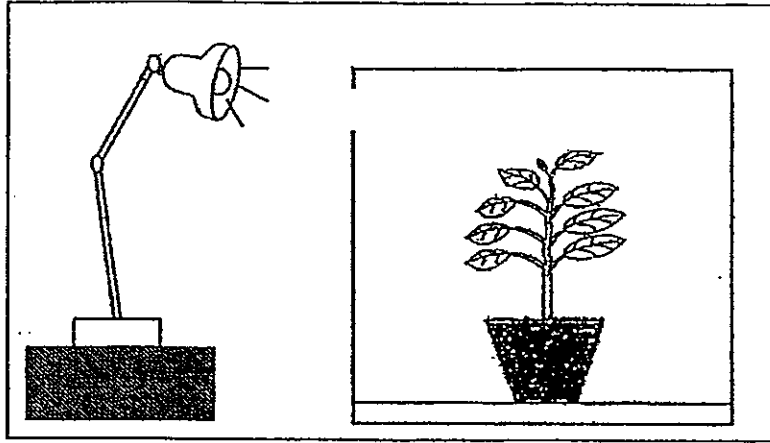

In the box below, draw what you think Yifang will observe about the plant after a week. (1m)

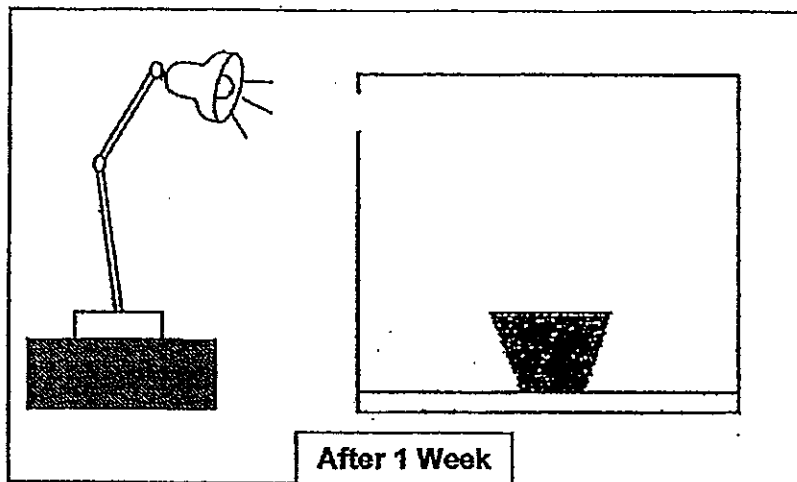



23. Siti drew an animal named 'Animal Y' as shown below.

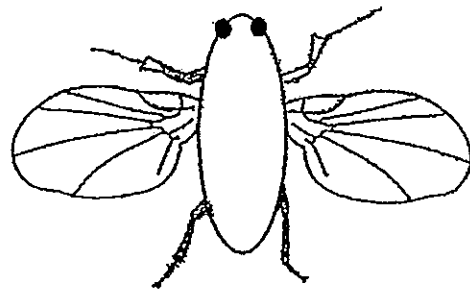

Animal Y

She wanted to classify Animal Y in the classification diagram below.

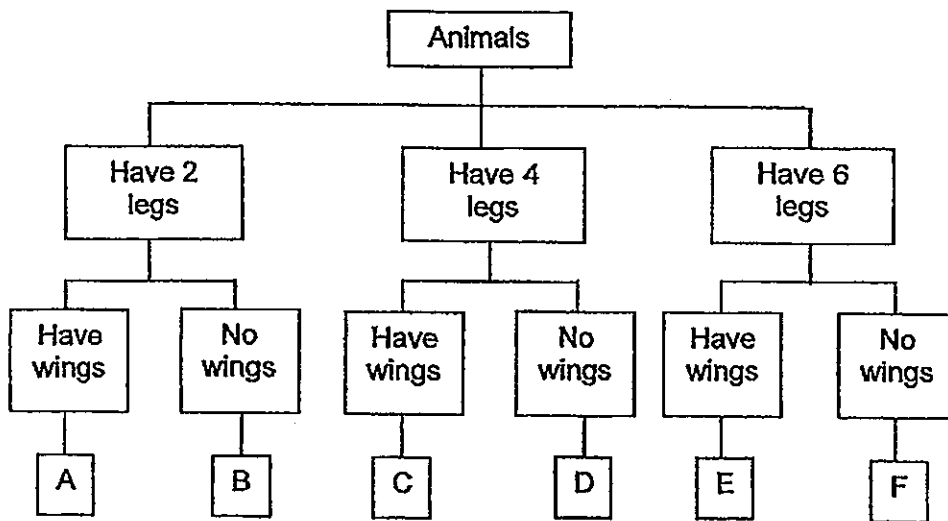

(a) Which letter (A, B, C, D, E or F) in the classification diagram best represents Animal Y? (1m)

---

(b) Which letter (A, B, C, D, E or F) in the classification diagram best represents a bird? Explain why. (1m)

---

---

24. Study the two organisms below.

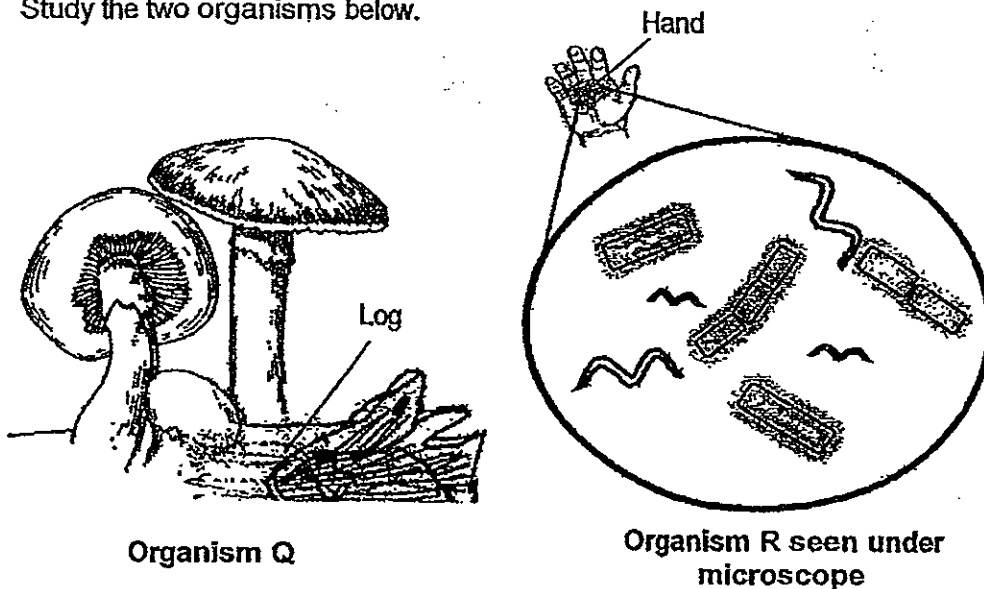

(a) In which group of living things do Organism Q and R belong to? (2m)

Organism Q : \_\_\_\_\_

Organism R : \_\_\_\_\_

(b) Based on the above diagram only, state one difference between Organism Q and R (1m)

---

---

25. Study the classification table below.

| Living Things   |             |
|-----------------|-------------|
| Group A         | Group B     |
| Sunflower plant | Fern        |
| Rose plant      | Bread mould |

- (a) Give a suitable heading for Group A and Group B with regard to how they reproduce. (2m)

Group A: \_\_\_\_\_

Group B: \_\_\_\_\_

The diagram below shows Plant Z.

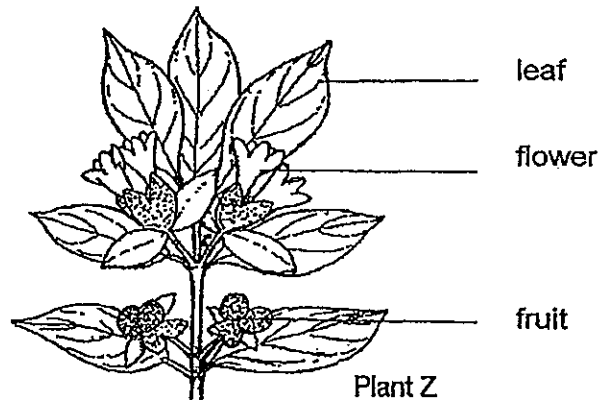

Syafiq said that it must be placed in Group A.

- (b) What did he observe on Plant Z that caused him to place Plant Z in Group A? (1m)

---



---

26. The flowchart below gives the characteristics of some animals.

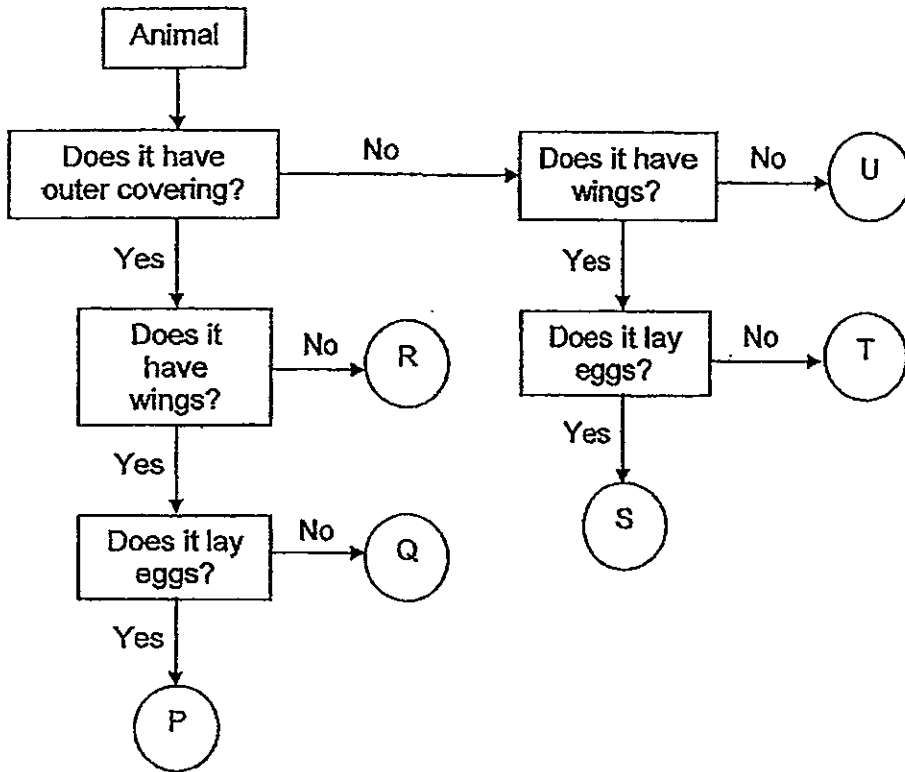

(a) State all the characteristics of Animal R. (1m)

---



---

(b) State two similarities between Animal P and Animal S. (2m)

---



---

(c) In which animal group do U and T belong to? Support your choice. (1m)

---



---

27. Melissa took a balloon and blew air into it. She drew her observation as shown in the diagram below.

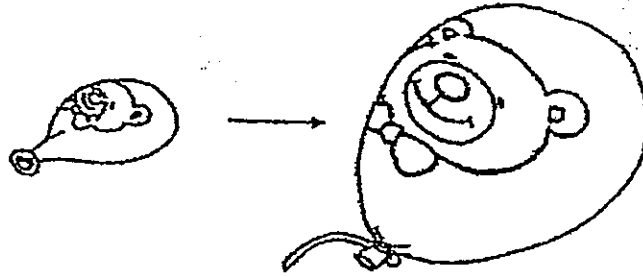

- (a) Describe what has happened to the balloon when air was blown into it. (1m)

---

---

- (b) What does her observation tell about the property of the material used to make the balloon? (1m)

---

---

28. Terrence carried out an experiment with three pieces of materials, W, X and Y. He placed each piece of material over a metal container. Then, he added some weights over it as shown in the diagram below. He continued adding the weights until the piece of material broke.

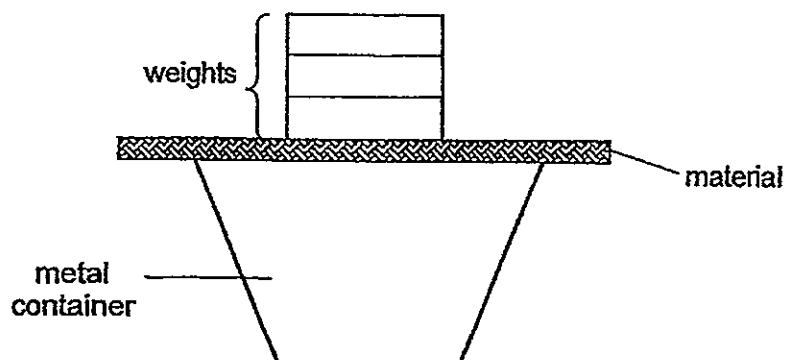

The table below shows the maximum weights taken to break each piece of material.

| Materials | Weights it could hold before it broke |
|-----------|---------------------------------------|
| W         | 20kg                                  |
| X         | 5kg                                   |
| Y         | 10kg                                  |

- (a) Arrange the materials (W, X and Y) according to their strength from the strongest to the weakest. (1m)

---

- (b) Based on the information given in the table above, which material, W, X or Y, is most suitable for making a stool? Support your answer. (1m)

---



---

29. Simon took four pieces of materials, A, B, C and D, of similar sizes and weighed them. He then placed them in a tank of water as shown in the diagram below.

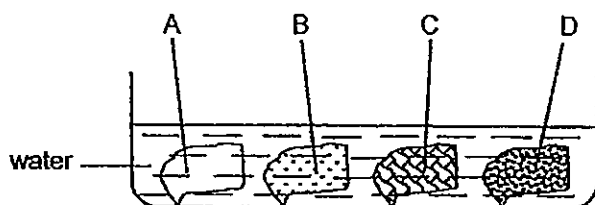

After ten minutes, he removed the materials from the water and weighed them again. He recorded the mass of the materials as shown in the table below.

| Material                               | A | B  | C | D |
|--|---|----|---|---|
| Mass of material before the experiment | 3 | 5  | 2 | 3 |
| Mass of material after the experiment  | 5 | 15 | 3 | 6 |

- (a) Which property of the material was tested in the above experiment? (1m)

---

- (b) Based on the information in the table, which material (A, B, C or D) is most suitable for making a face towel? Support your choice. (1m)

---



---

30. Lesley put three objects, A, B and C, into a container of water. The objects are of the same size. The diagram below shows his observation.

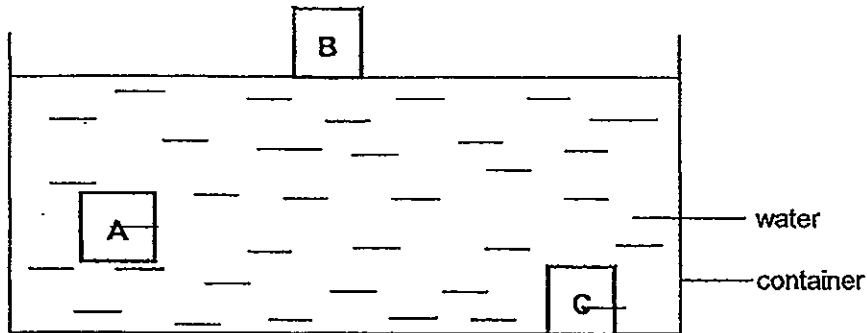

- (a) Classify all the objects (A, B and C) into two groups. Write the letters in the table below. (1m)

| Sinks in Water | Floats in Water |
|----------------|-----------------|
|                |                 |

Next, Lesley put Object D into the container of water. Object D is the same size as A, B and C but it is made of a lighter material than A and C and a heavier material than B.



Object D

- (b) Draw Object D in the container of water above. (1m)
- (c) Lesley said that object C is made of metal. Do you agree with him? Support your answer with a reason. (1m)

---



---



31. Study the flowchart below.

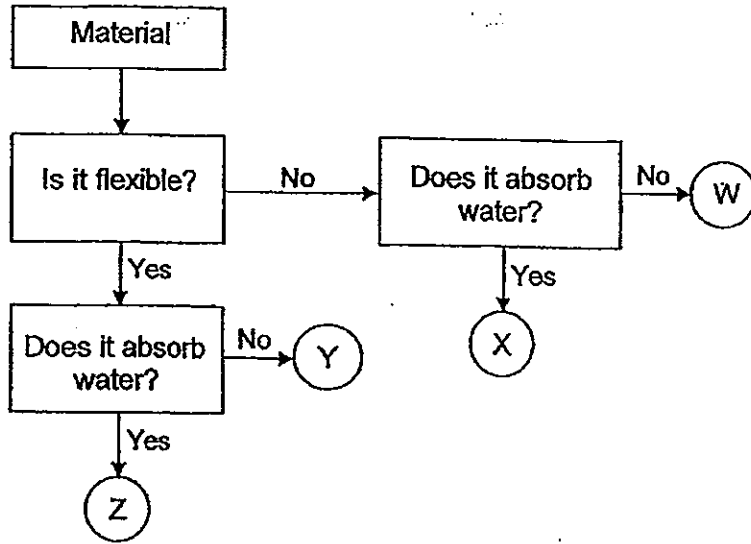

- (a) Material Y is used to make umbrellas. Based on the flowchart, state the properties of Material Y that make it suitable. (1m)

---



---

- (b) Choose a property from the flowchart above and write them as headings in the classification chart below, (i) and (ii). Then classify W, X, Y and Z into the two groups in the classification chart. (2m)

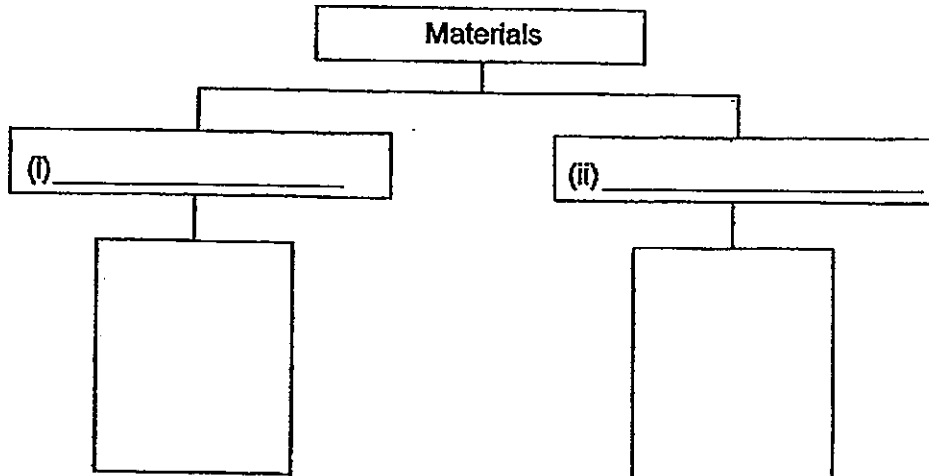

32. Linda wanted to make an electromagnet. She set up the experiment as shown below using two new batteries, a switch, a wire and an aluminium rod. She put some iron nails near the rod.

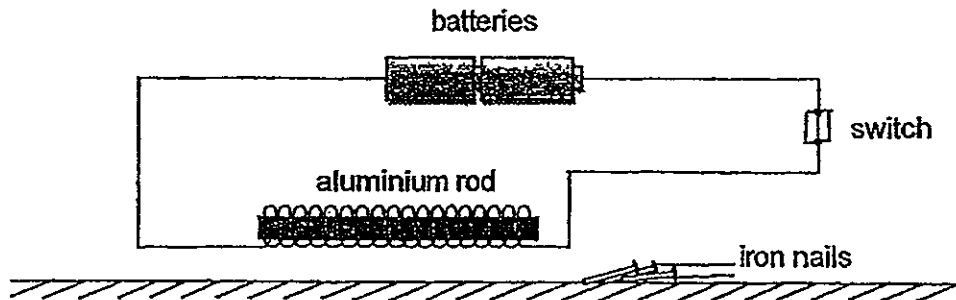

- (a) When Linda turned on the switch, she observed that the iron nails were not attracted to the rod. Explain her observation. (1m)

---

---

- (b) What must she do in the above set-up to enable the iron nails to be attracted to the rod? (1m)

---

---

End of Paper



# ANSWER SHEET

**EXAM PAPER 2013**

**SCHOOL : ROSYTH PRIMARY SCHOOL**

**SUBJECT : PRIMARY 3 SCIENCE**

**TERM : SA1**

|    |    |    |    |    |    |    |    |    |     |     |     |     |     |     |     |     |
|----|----|----|----|----|----|----|----|----|-----|-----|-----|-----|-----|-----|-----|-----|
| Q1 | Q2 | Q3 | Q4 | Q5 | Q6 | Q7 | Q8 | Q9 | Q10 | Q11 | Q12 | Q13 | Q14 | Q15 | Q16 | Q17 |
| 1  | 3  | 2  | 2  | 2  | 4  | 3  | 3  | 1  | 1   | 4   | 1   | 3   | 3   | 2   | 4   | 4   |

|     |     |     |
|-----|-----|-----|
| Q18 | Q19 | Q20 |
| 2   | 4   | 2   |

Section B

Q21

- a) From week 1 to week 5 the height of the chick increased but from week 5 to 6 the height remained the same  
b) Living things grow

Q22

- a) H will survive the longest because it has air, sunlight and water to stay alive  
b)

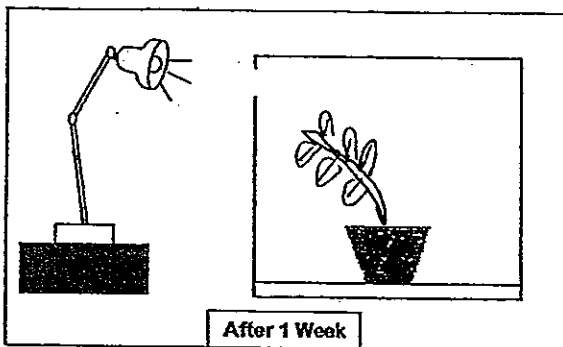

Q23

- a) C best represents animal Y
- b) A, birds have 2 legs and a pair of wings

Q24

- a) Q: Fungi  
R: Bacteria
- b) Organism R can be seen under the microscope but organisms can be seen with naked eye

Q25

- a) A: Reproduce by seeds  
B: Reproduce by spores
- b) He observed that it had flowers and Group A also had flowers so they both are flowering plants

Q26

- a) Animal R has outer covering but does not have wings
- b) Both animal P and S lay eggs and have wings
- c) It belongs in the Insect group because they do not have outer covering.

Q27

- a) It expanded from a small balloon to a big balloon
- b) The property is flexibility

Q28

- a) W, Y, X
- b) W is able to hold the heaviest material as it is the strongest material

Q29

- a) Absorbency was tested
- b) B has absorbed the most amount of water

Q30

a)

| Sinks in water | Floats in water |
|----------------|-----------------|
| A              | B               |
| C              |                 |

b)

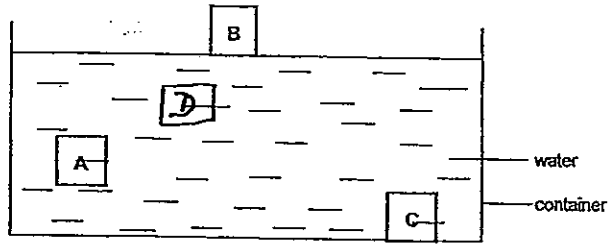

c) Yes, metal is heavier than water it will sink to the bottom of the container

Q31

- a) The properties of Material Y are it is flexible and does not absorb water.
- b) i) can absorb – X, Z
- ii) cannot absorb – W, Y

Q32

- a) Aluminium is a non-magnetic material
- b) She can change the aluminium rod to a iron or steel rod.





Rosyth School  
Second Topical Test for 2013  
**SCIENCE**  
Primary 3

Name: \_\_\_\_\_

Total  
Marks:

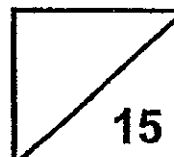

Class: Pr 3 \_\_\_\_\_

Register No. \_\_\_\_\_

Duration: 30 minutes

Date: 22 August 2013

Parent's Signature: \_\_\_\_\_

Instructions to Pupils:

1. Do not open the booklet until you are told to do so.
2. Follow all instructions carefully.
3. This paper consists of 2 parts, Part I and Part II.
4. For questions 1 to 10, write the correct answer in the brackets provided.
5. For questions 11 and 12, give your answers in the spaces provided in Part II.

|         | Maximum  | Marks Obtained |
|---------|----------|----------------|
| Part I  | 10 marks |                |
| Part II | 5 marks  |                |
| Total   | 15 marks |                |

\* This booklet consists of 7 pages.

This paper is not to be reproduced in part or whole without the permission of the Principal.



SINGAPORE CHINESE GIRLS' SCHOOL  
 FIRST SEMESTRAL ASSESSMENT 2013  
 PRIMARY 3  
 SCIENCE

Name: \_\_\_\_\_ (     )

Date: \_\_\_\_\_

Class: Primary 3

| Components | Marks Obtained | Maximum Mark |
|------------|----------------|--------------|
| Part I     |                | 30           |
| Part II    |                | 20           |
| Total      |                | 50           |

Parent's Signature: \_\_\_\_\_

**Part II ( 20 marks)**

Answer the following questions.

16. The table below shows some characteristics of Animals X and Y.

|          | Has fins | Has a tail | Gives birth to young<br>alive | Suckles its young with<br>milk |
|----------|----------|------------|-------------------------------|--------------------------------|
| Animal X | √        | √          | √                             | √                              |
| Animal Y | √        | √          |                               |                                |

a) Write down the similarities between Animal X and Animal Y.

[1]

b) Write down the Animal Group that Animal X and Animal Y belong to.

[2]

Animal X: \_\_\_\_\_

Animal Y: \_\_\_\_\_

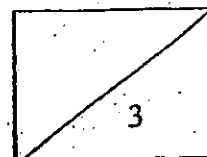

17. Susan went on a holiday for a week in June. She bought an automatic food dispenser and placed it in her fish tank. She also had an air pump in her fish tank. There was a short circuit in her home on the first day and electricity was cut off. It caused the air pump in the tank to stop working.

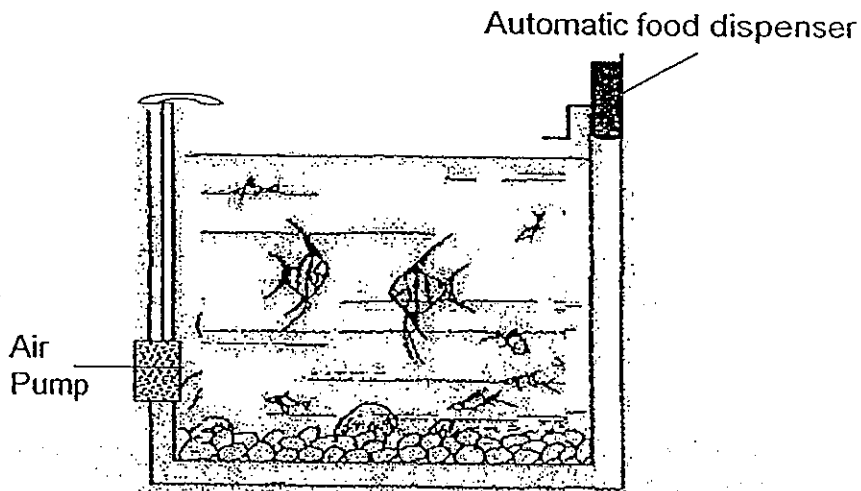

- a) Before Susan left for her holiday, she ensured that her fish had the 3 things they needed to survive. What are the 3 things? [1]

i) \_\_\_\_\_ ii) \_\_\_\_\_ iii) \_\_\_\_\_

- b) However, when Susan returned home from her holiday, she discovered that some of her fish had died even though there was still fish food in the tank.

Why did some of her fish die? [1]

---



---

18. Label the different parts of the beetle. [2]

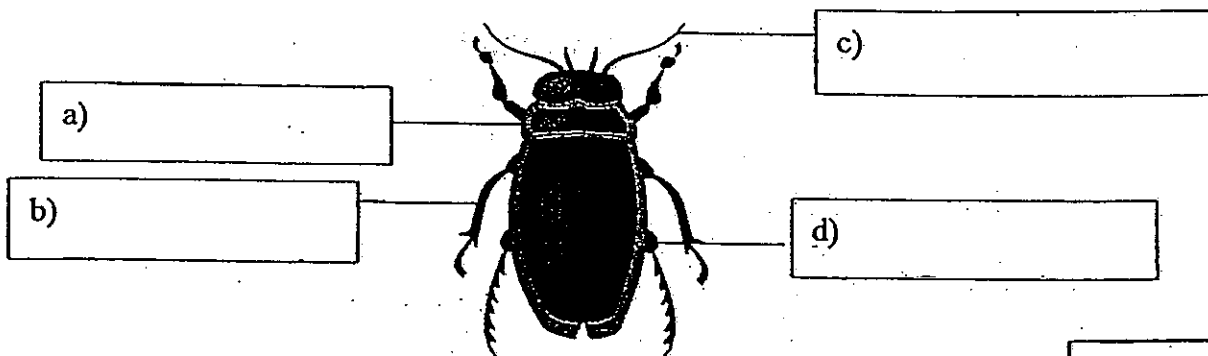

19. Linda has been given 4 plants as listed in the box below. Help her place the correct plant under the correct heading. [2]

|               |         |                  |            |
|---------------|---------|------------------|------------|
| Mosquito fern | Jasmine | Bird's nest fern | Water lily |
|---------------|---------|------------------|------------|

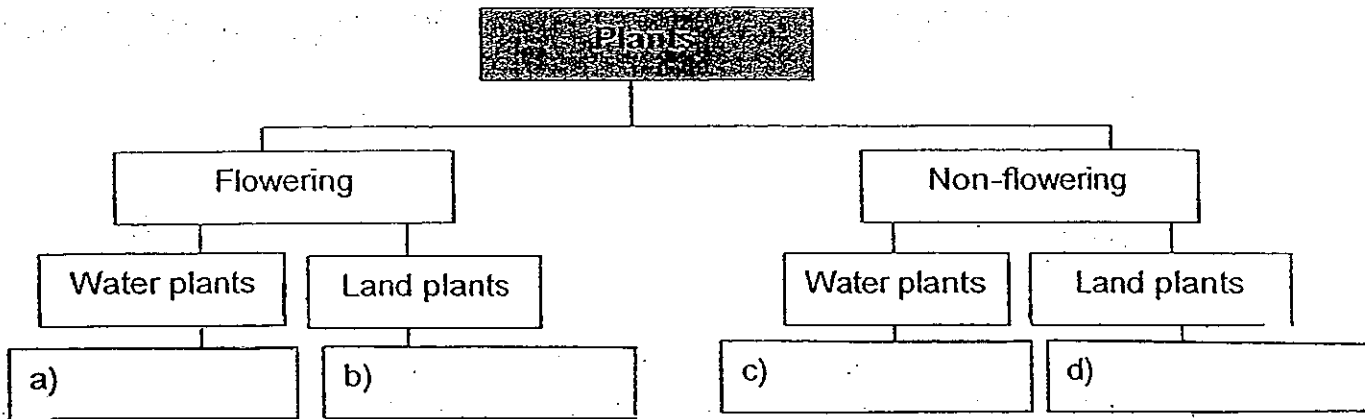

20. Jenny conducted an experiment as shown by the table below. Three slices of white bread; X, Y and Z of equal size were cut from the same loaf. The table below shows the places the three slices of white bread were kept. She wanted to find out which slice(s) of bread would have bread mould on it first.

| White bread | Number of teaspoons of water added before being put in zip-lock bags | Where the slices of white bread were placed |
|-------------|--|---|
| X           | 4  | Under the sun                               |
| Y           | 4  | Storeroom                                   |
| Z           | 4  | Refrigerator                                |

a) On which slice(s) of bread would bread mould most likely to appear first? [1]

b) Write down the conditions that enable bread mould to grow the fastest in (a). [1]

c) If Jenny had used brown instead of white bread for the experiment, why do you think she would have difficulty getting her results? [1]

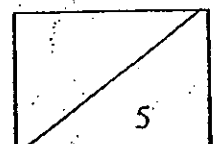

21. Look carefully at the flow chart.

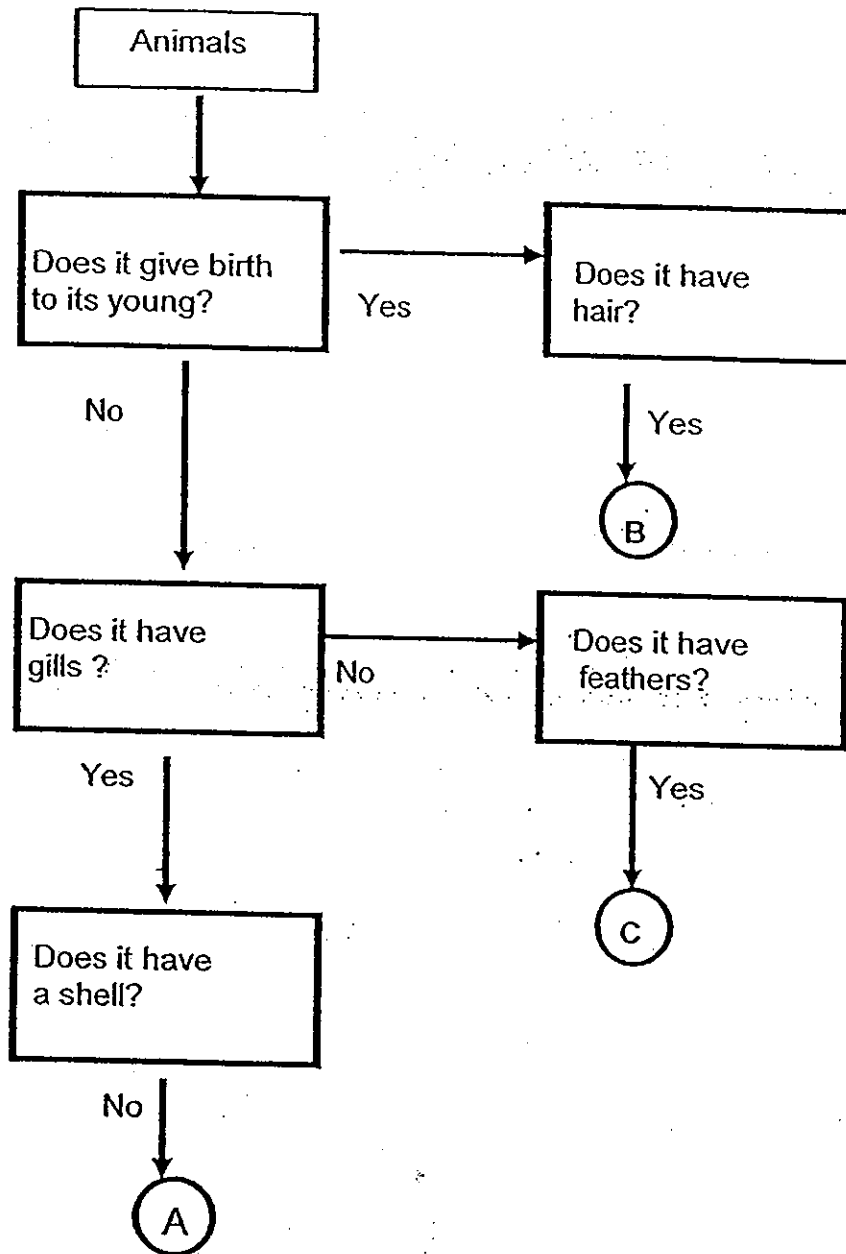

Use the helping words in the boxes and match them with animals A, B and C. [3]

|         |           |       |       |
|---------|-----------|-------|-------|
| ostrich | clownfish | whale | snail |
|---------|-----------|-------|-------|

- a) Animal A : \_\_\_\_\_
- b) Animal B: \_\_\_\_\_
- c) Animal C: \_\_\_\_\_

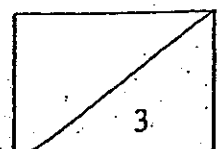

22. Read the statements carefully and circle the correct answer. [2]

|    |                                  |              |
|----|----------------------------------|--------------|
| a) | Bacteria are micro-organisms.    | True / False |
| b) | Fungi reproduce by seeds.        | True / False |
| c) | Puffball is an example of fungi. | True / False |
| d) | All bacteria harm our body.      | True / False |

23. Study the flow chart below.

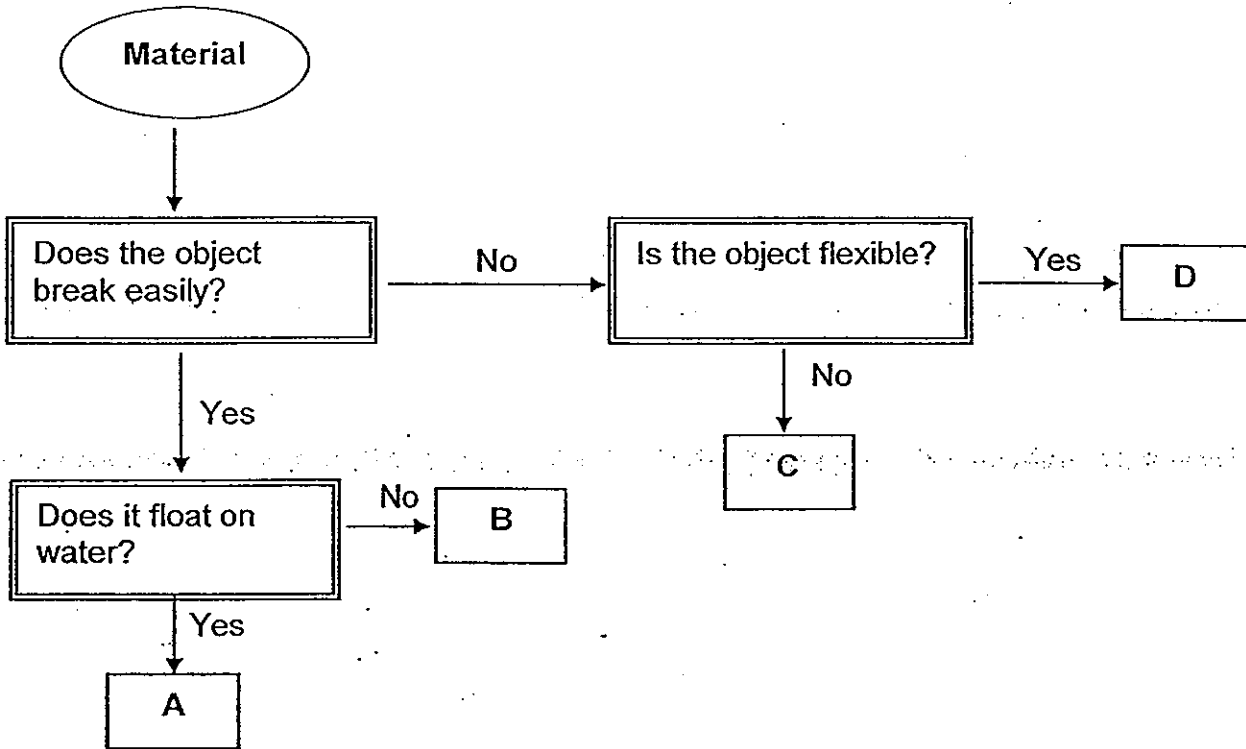

a) Write down all the characteristics of Object B. [1]

---



---

b) Using the flow chart, put a tick (✓) which shows the characteristic and a cross (X) if it does not show the characteristic of Objects C and D in the table below. [2]

| Objects | Flexible? | Breakable? |
|---------|-----------|------------|
| C       |           |            |
| D       |           |            |

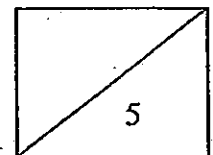

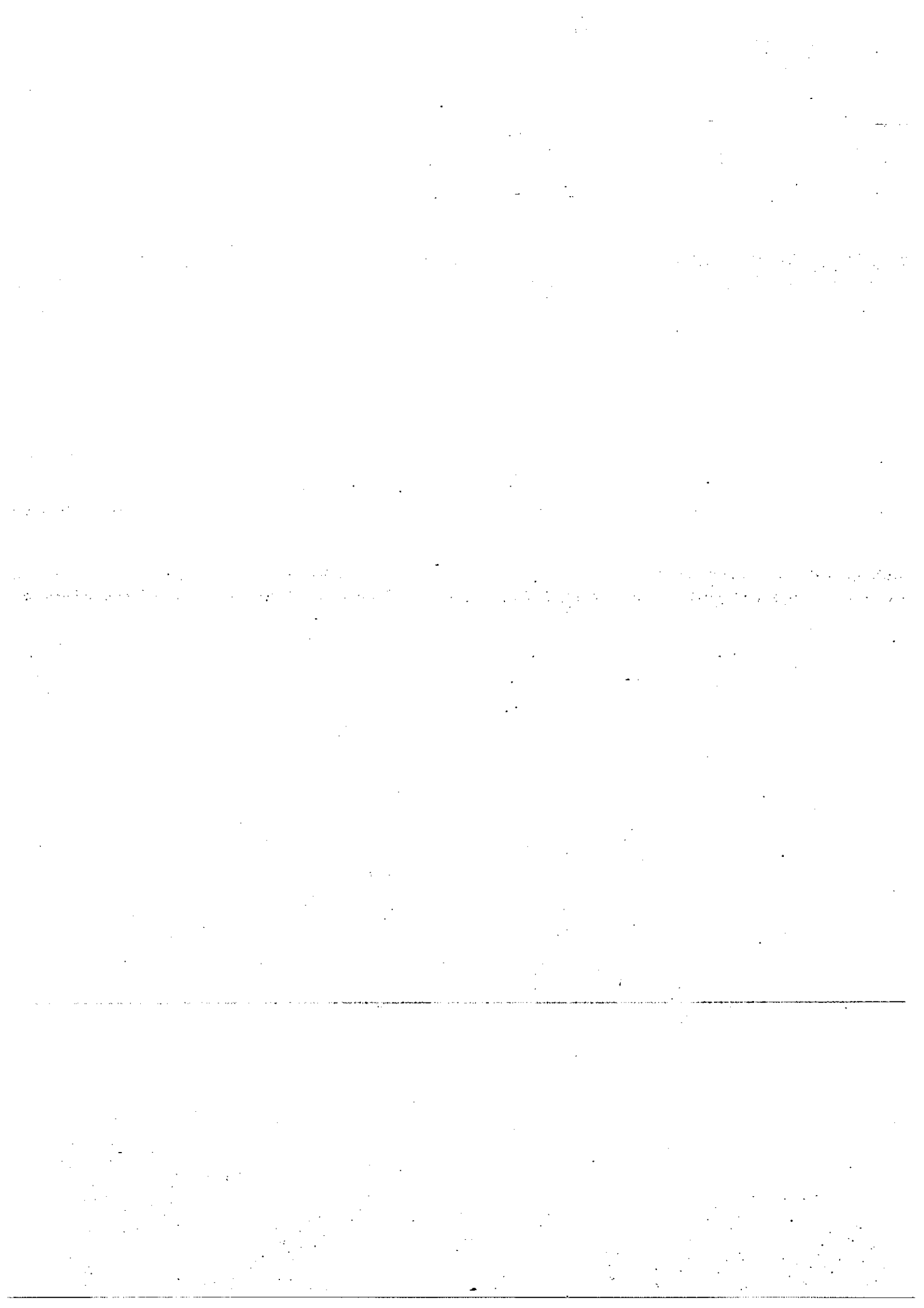

# ANSWER SHEET

**EXAM PAPER 2013**

**SCHOOL : SINGAPORE CHINESE GIRLS' SCHOOL**

**SUBJECT : PRIMARY 3 SCIENCE**

**TERM : SA1**

|    |    |    |    |    |    |    |    |    |     |     |     |     |     |     |
|----|----|----|----|----|----|----|----|----|-----|-----|-----|-----|-----|-----|
| Q1 | Q2 | Q3 | Q4 | Q5 | Q6 | Q7 | Q8 | Q9 | Q10 | Q11 | Q12 | Q13 | Q14 | Q15 |
| 3  | 2  | 2  | 1  | 4  | 2  | 4  | 4  | 1  | 3   | 4   | 4   | 4   | 3   | 1   |

## Part II

Q16

- a) Both have a fin and tail
- b) X: Mammals  
Y: Fish

Q17

- a) i) air  
ii) food  
iii) water
- b) Because the air pump in the tank was not working so the fish did not have enough air to breathe

Q18

- a) thorax
- b) legs
- c) feelers
- d) abdomen

Q19

- a) Water Lily

- b) Jasmine
- c) Mosquito fern
- d) Bird's nest fern

Q20

- a) Y
- b) Dark and warm
- c) If the bread was brown, she would have difficulty finding out where the mould is on the bread as the mould is dark-coloured and may blend in with the colours of the brown bread

Q21

- a) clownfish
- b) whale
- c) ostrich

Q22

- a) True
- b) False
- c) True
- d) False

Q23

- a) It breaks easily and it does not float on water
- b)

| Objects | Flexible? | Breakable? |
|---------|-----------|------------|
| C       | X         | X          |
| D       | √         | X          |





## PRIMARY 3 MID-YEAR EXAMINATION 2013

Name : \_\_\_\_\_ (      ) Date: 20 May 2013

Class : Primary 3 (      )

Time: 8.00 a.m. to 9.30 a.m.

Parent's Signature : \_\_\_\_\_

Marks: \_\_\_\_\_ / 40

# SCIENCE BOOKLET A

### INSTRUCTIONS TO CANDIDATES

Write your name, register number and class.

Do not turn over this page until you are told to do so.

Follow all instructions carefully.

Answer all questions.

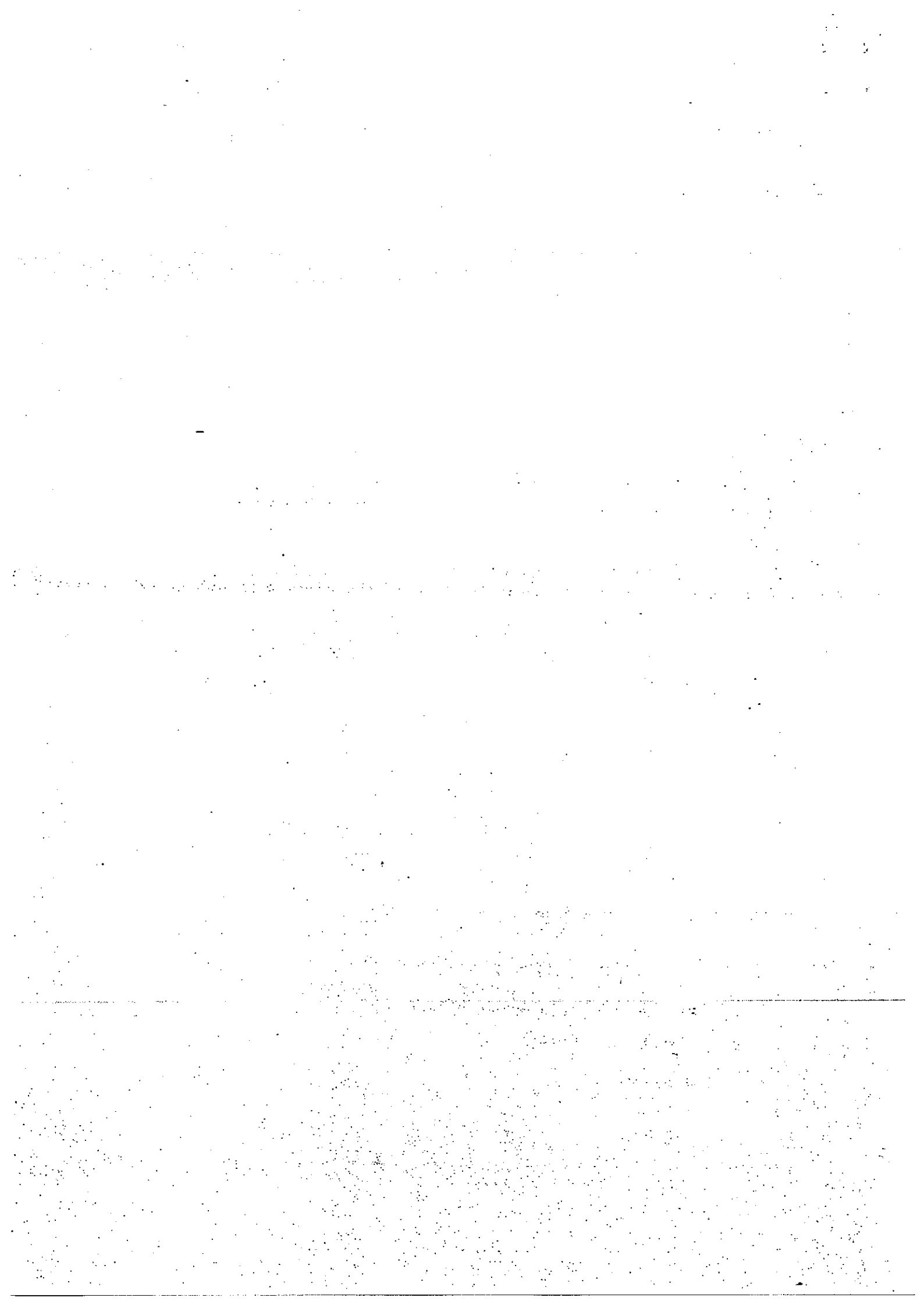

**Section A ( 20 x 2 marks = 40 marks)**

For each question, choose the most suitable answer and shade its corresponding oval (1, 2, 3 or 4) in the optical answer sheet.

1. Study the classification table below.

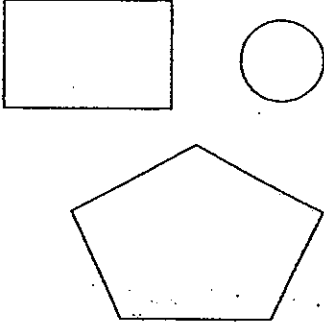
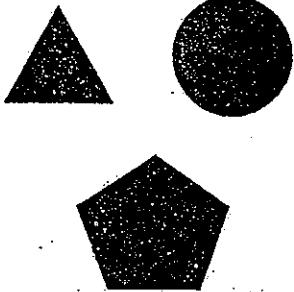
| Group X   | Group Y  |
|---|--|
|  |  |

How are the things in Group X and Group Y classified?

- (1) Things in Group X and Group Y are grouped according to size.
- (2) Things in Group X and Group Y are grouped according to shape.
- (3) Things in Group X and Group Y are grouped according to colour.
- (4) Things in Group X and Group Y are grouped according to pattern.

2. Which of the following is grouped correctly?

|     | Living thing | Non-living thing |
|-----|--------------|------------------|
| (1) | Mushroom     | Tree             |
| (2) | Frog         | Spoon            |
| (3) | Mirror       | Bacteria         |
| (4) | Watch        | Raincoat         |

3. Angela saw a dragonfly at a pond. She tried to catch the dragonfly but it flew away. What characteristic of living things did the dragonfly show?

- (1) It can die.
- (2) It can grow.
- (3) It lays eggs.
- (4) It can move on its own.

4. Which of the following graphs show the height of a healthy growing child?

(1)

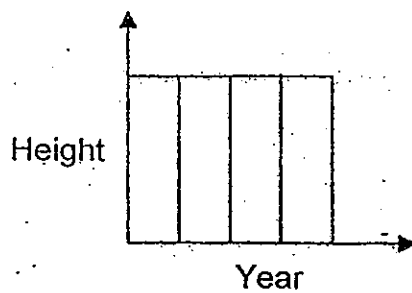

(2)

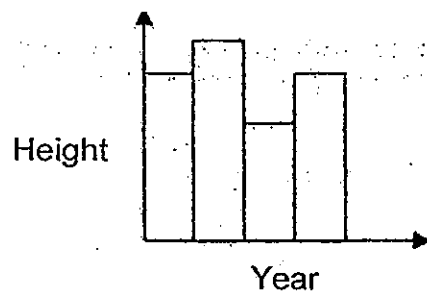

(3)

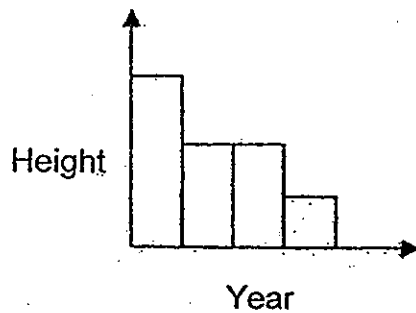

(4)

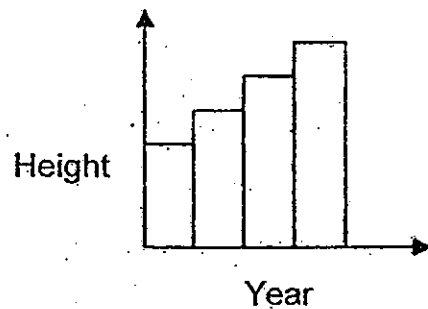

5. Melissa placed a potted plant in a dark cupboard. After a week, the plant withered even though she watered it daily.

What can Melissa conclude from this?

- (1) Plants can grow.
- (2) Plants can reproduce.
- (3) Plants need sunlight to live.
- (4) Plants cannot move around freely.

6. In the classification chart below, the fruits are grouped according to certain characteristics.

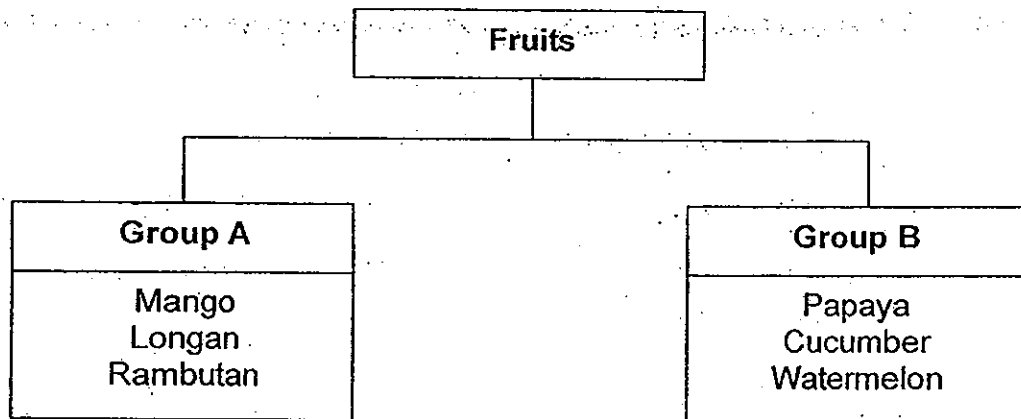

Which one of the following shows the correct characteristics of the fruits in Group A and Group B?

|     | Group A      | Group B     |
|-----|--------------|-------------|
| (1) | Edible       | Inedible    |
| (2) | Yellow flesh | Red flesh   |
| (3) | Rough skin   | Smooth skin |
| (4) | Single seed  | Many seeds  |

7. Study the classification chart below.

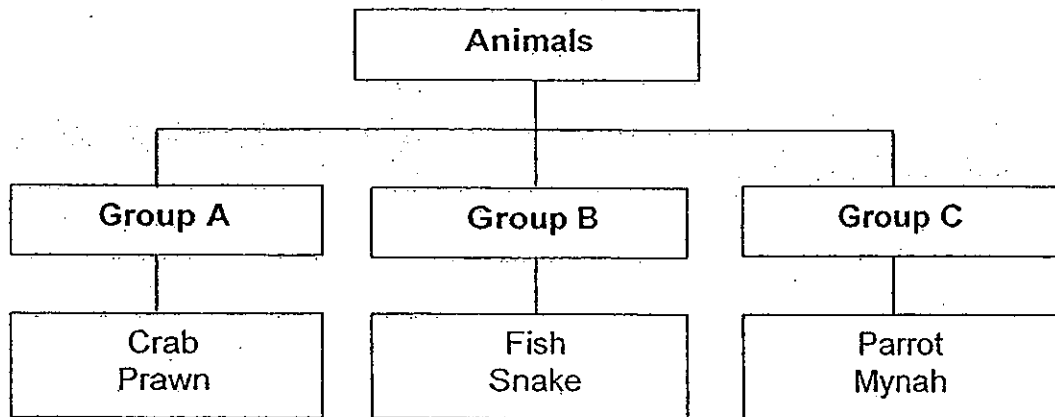

How are the animals above grouped?

- (1) By their shape
- (2) By the way they move
- (3) By the way they reproduce
- (4) By their outer body coverings

8. Study the diagram below.

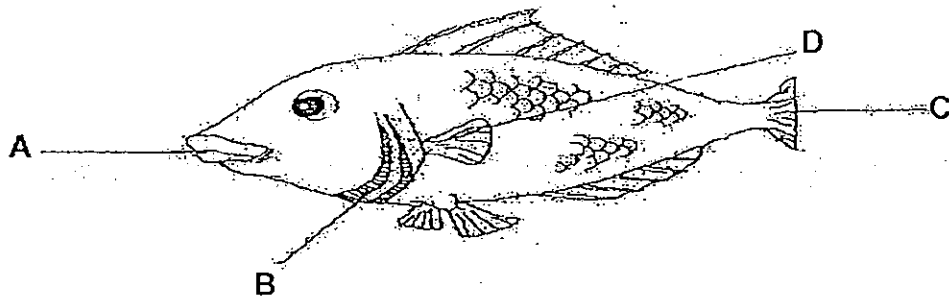

Which of the following correctly represents the body parts of the fish?

|     | A          | B          | C     | D          |
|-----|------------|------------|-------|------------|
| (1) | Gill Cover | Mouth      | Fin   | Tail       |
| (2) | Mouth      | Gill Cover | Tail  | Fin        |
| (3) | Tail       | Fin        | Mouth | Gill Cover |
| (4) | Fin        | Mouth      | Tail  | Gill Cover |

9. Study the flowchart below.

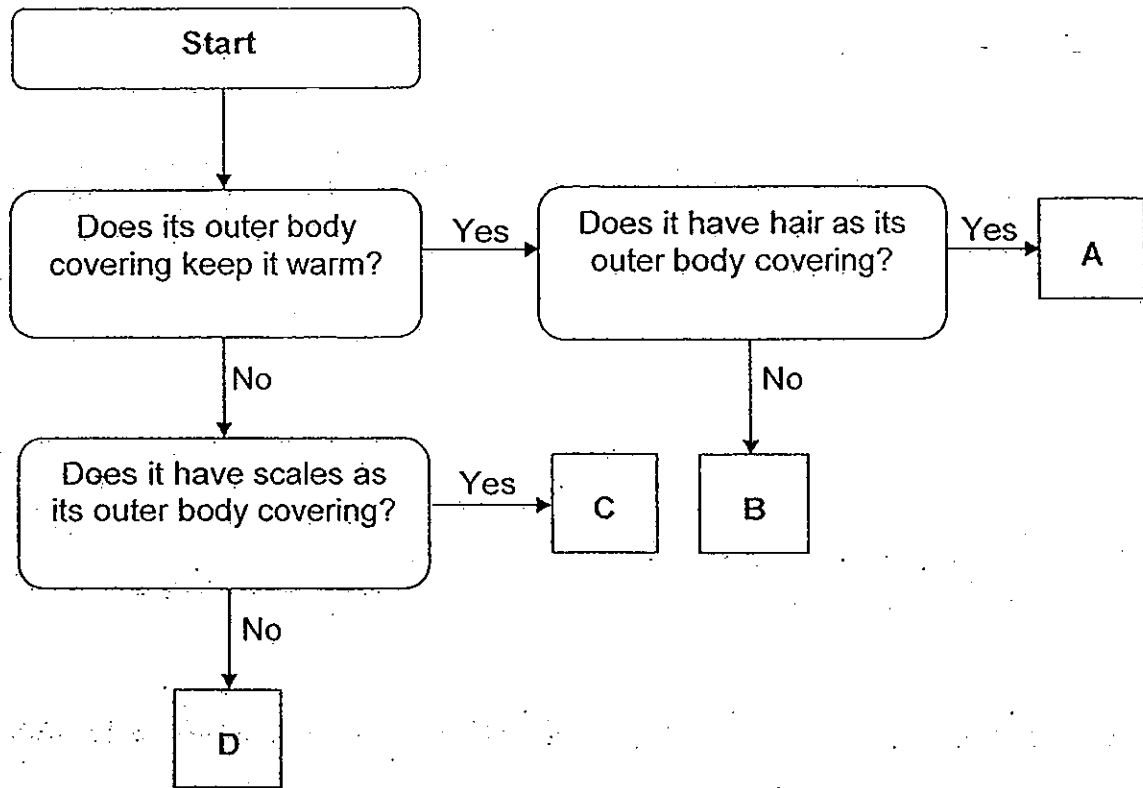

Which of the following animals represent A, B, C and D?

|     | A         | B              | C         | D           |
|-----|-----------|----------------|-----------|-------------|
| (1) | Lion      | Guppy          | Ostrich   | Platypus    |
| (2) | Butterfly | Bear           | Whale     | Crab        |
| (3) | Rabbit    | Penguin        | Goldfish  | Mosquito    |
| (4) | Eagle     | Spiny Anteater | Angelfish | Grasshopper |



10. Study the classification chart below.

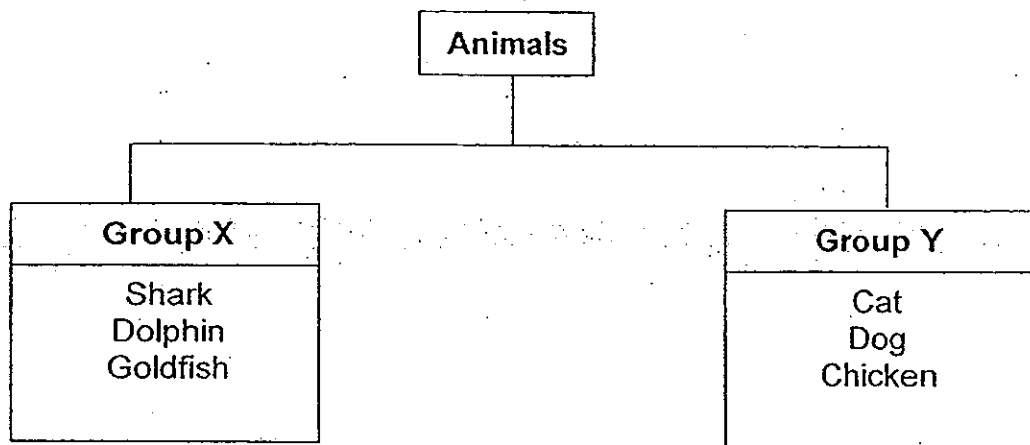

Which of the following represent Group X and Group Y?

|     | Group X                    | Group Y                                |
|-----|----------------------------|--|
| (1) | Animals that swim          | Animals that fly                       |
| (2) | Animals without hair       | Animals with hair                      |
| (3) | Animals that live in water | Animals that live on land              |
| (4) | Animals that lay eggs      | Animals that give birth to young alive |

11. Study the flowchart below.

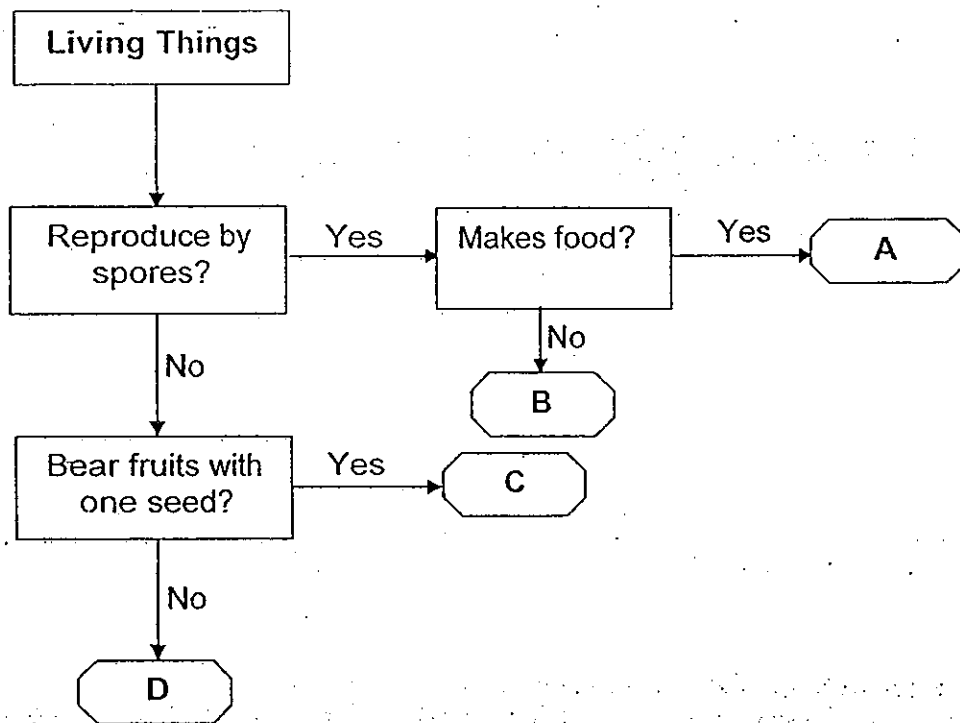

Which of the following represent A, B, C and D?

|     | A                | B           | C          | D             |
|-----|------------------|-------------|------------|---------------|
| (1) | Orchid           | Mushroom    | Mango Tree | Rambutan Tree |
| (2) | Bird's Nest Fern | Bread Mould | Cactus     | Rambutan Tree |
| (3) | Staghorn Fern    | Bread Mould | Mango Tree | Durian Tree   |
| (4) | Rose Plant       | Mushroom    | Cactus     | Durian Tree   |

12. Angeline carried out an experiment to find out more about the growth of mould on 4 pieces of similar bread slices.

| Bread slice | What Angeline did to the bread slice?                             | Location of the bread slice |
|-------------|---|-----------------------------|
| A           | Sprinkled water on the bread slice then toasted it for 10 minutes | In a freezer                |
| B           | Sprinkled water on the bread slice                                | In a freezer                |
| C           | Sprinkled water on the bread slice then toasted it for 10 minutes | In a cupboard               |
| D           | Sprinkled water on the bread slice                                | In a cupboard               |

On which piece of bread slice was she likely to observe mould being formed the fastest?

- (1) A
- (2) B
- (3) C
- (4) D

13. The characteristics of W, X, Y and Z are given in the table below.

| Characteristics                        | W   | X   | Y   | Z   |
|--|-----|-----|-----|-----|
| Responds to changes?                   | Yes | No  | Yes | Yes |
| Can only be seen through a microscope? | No  | Yes | Yes | No  |
| Can make its own food?                 | No  | No  | No  | Yes |

Which of the following is a micro-organism?

- (1) W
- (2) X
- (3) Y
- (4) Z

14. Three pupils, Carole, Jonathan and Christopher were talking about Organism Y.

Carole: It can make us sick.

Jonathan: It is so tiny. I cannot see it.

Christopher: It can be used to turn milk into yoghurt.

What is Organism Y?

- (1) Ant
- (2) Moss
- (3) Mould
- (4) Bacteria

15. Why are the lenses of a pair of spectacles made of either clear glass or clear plastic?



- (1) These materials are light.
- (2) These materials are thick.
- (3) These materials are strong.
- (4) These materials are transparent.

16. The objects in the classification chart below are classified according to the materials they are made of.

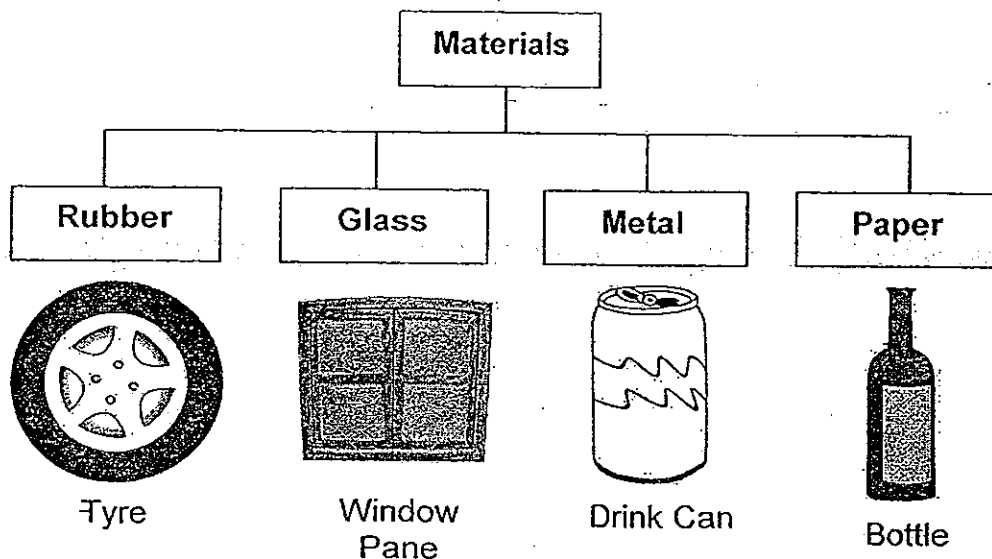

Which object in the classification chart above is classified **incorrectly**?

- (1) Tyre
  - (2) Bottle
  - (3) Drink Can
  - (4) Window Pane
17. Below shows a frying pan with parts labelled A and B.

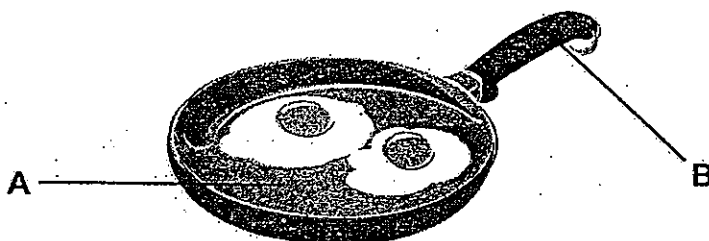

Which of the following are materials that are suitable for making the parts A and B?

|     | A       | B       |
|-----|---------|---------|
| (1) | Glass   | Ceramic |
| (2) | Metal   | Plastic |
| (3) | Plastic | Metal   |
| (4) | Rubber  | Glass   |

18. Which of the following is made of more than one material?

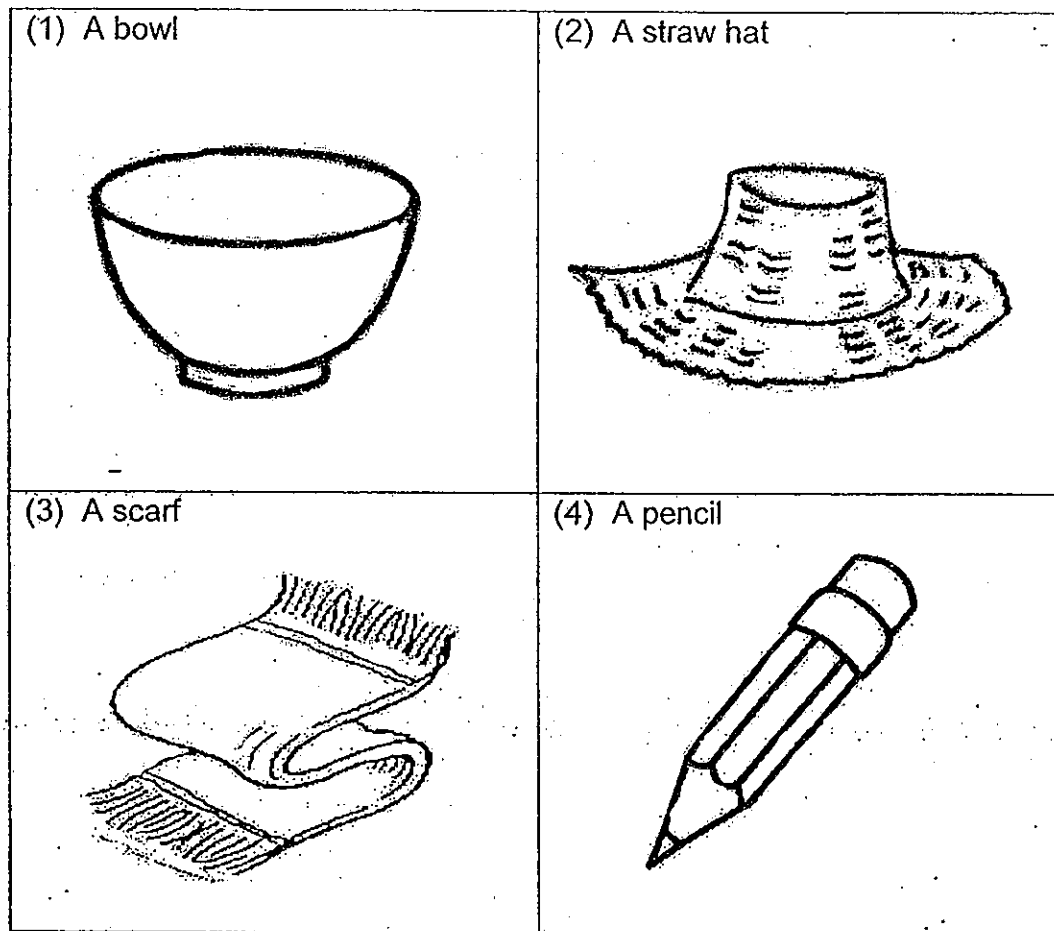

19. Which of the following comes from plants?

- (1) Silk
- (2) Wool
- (3) Rubber
- (4) Leather

20. Study the flowchart below.

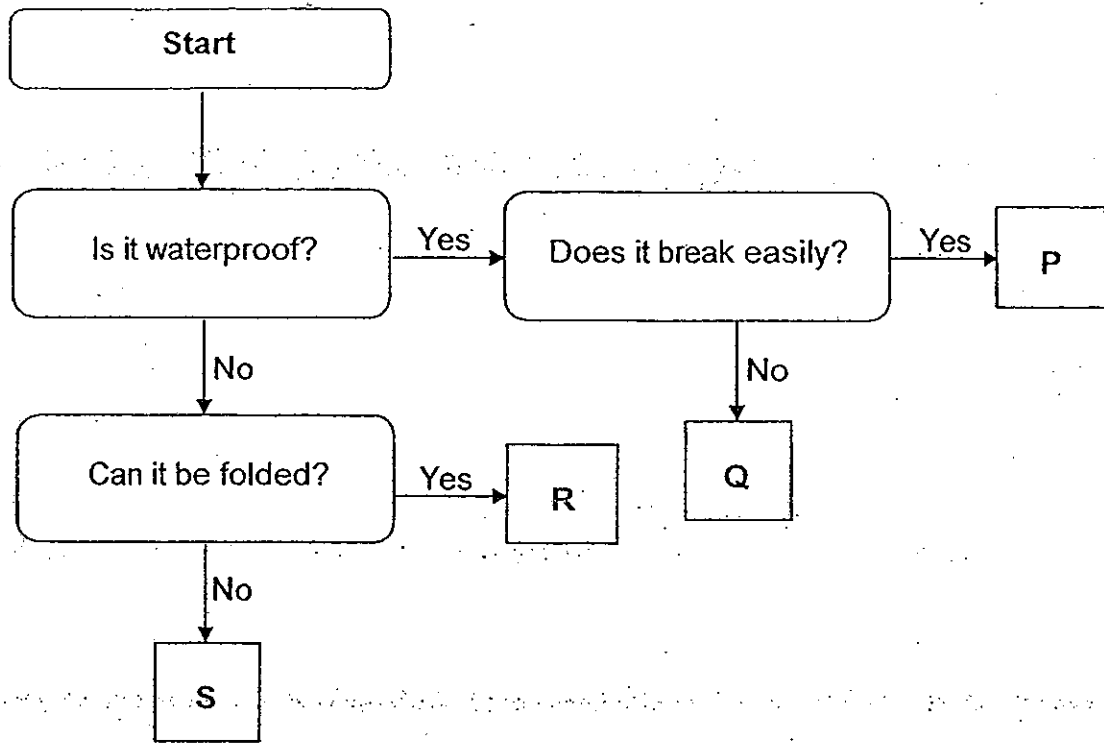

Where will you place a porcelain cup and a bath towel?

|     | Porcelain Cup | Bath Towel |
|-----|---------------|------------|
| (1) | S             | Q          |
| (2) | P             | R          |
| (3) | Q             | S          |
| (4) | R             | P          |

– End of Booklet A –

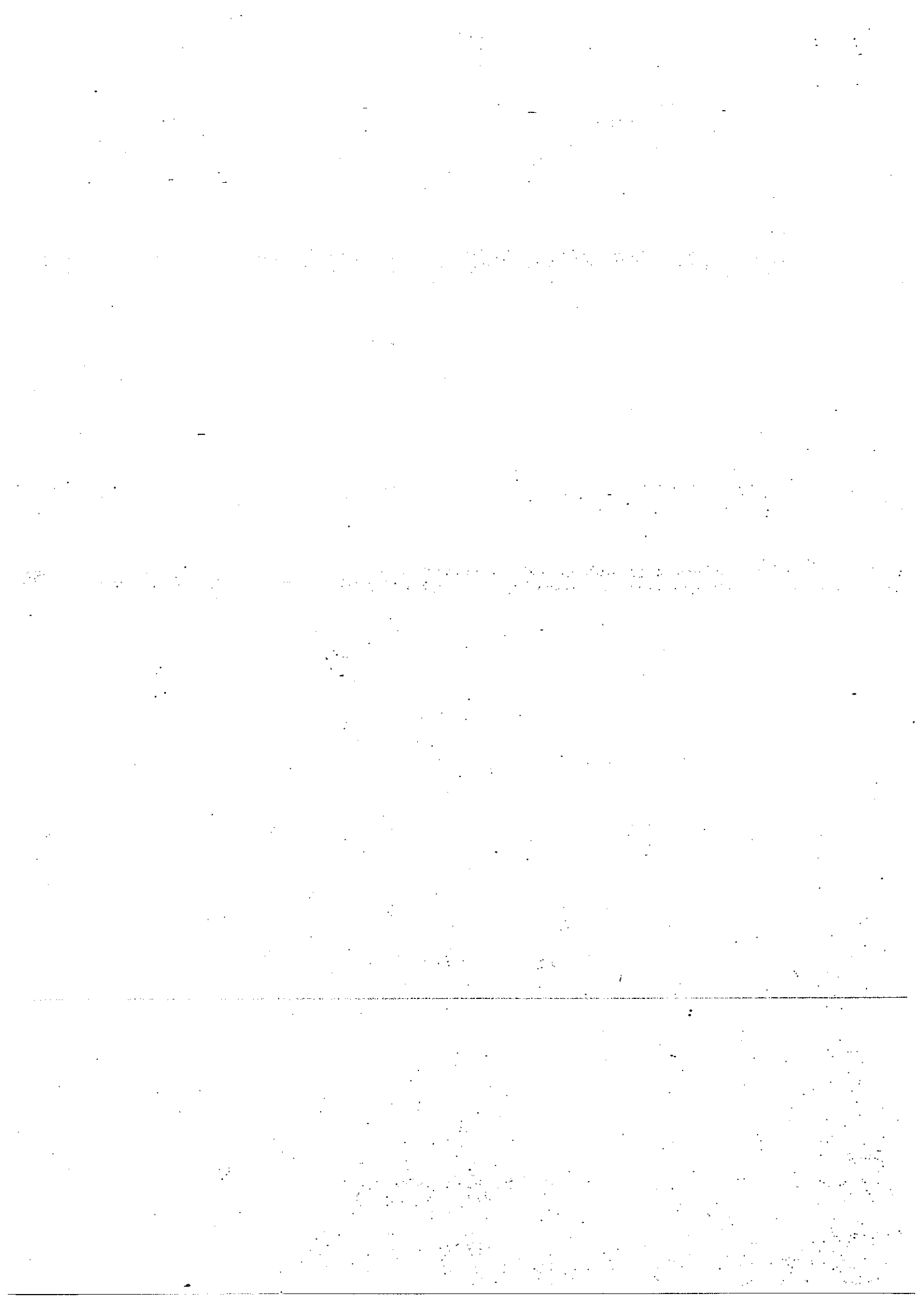





## PRIMARY 3 MID-YEAR EXAMINATION 2013

Name : \_\_\_\_\_ ( ) Date: 20 May 2013

Class : Primary 3 ( )

Time: 8.00 a.m. to 9.30 a.m.

Parent's Signature : \_\_\_\_\_

Marks: \_\_\_\_\_ / 30

# SCIENCE BOOKLET B

### INSTRUCTIONS TO CANDIDATES

Write your name, register number and class.

Do not turn over this page until you are told to do so.

Follow all instructions carefully.

Answer all questions.



Section B (30 marks)

Write your answers in the spaces provided.

21. (a) The following tells us the characteristics of living things.

| Characteristics |   |
|-----------------|---|
| A:              | Living things grow.                     |
| B:              | Living things move.                     |
| C:              | Living things reproduce.                |
| D:              | Living things need air, food and water. |

Match the activities below to the characteristics above.  
Write A, B, C or D in the spaces provided.

(2m)

| Activities                     | Characteristics |
|--------------------------------|-----------------|
| (1) A bird lays an egg.        |                 |
| (2) A frog swims in a pond.    |                 |
| (3) A chick grows into a hen.  |                 |
| (4) A cheetah feeds on a deer. |                 |

(b) Karen placed a mouse in a glass container together with a dish of water and some food as shown below. Then she covered and sealed the box to prevent the mouse from getting out. A few days later, the mouse was dead.

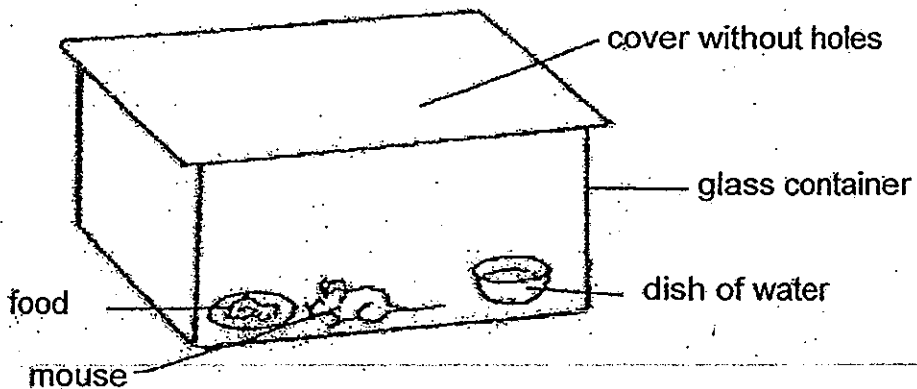

Explain why the mouse died.

(1m)

---

---

22. Classify the objects below under the correct headings of the classification chart provided. (3m)

| Objects       |         |        |
|---------------|---------|--------|
| Bicycle       | Shirt   | Pigeon |
| Venus flytrap | Dolphin | Wallet |

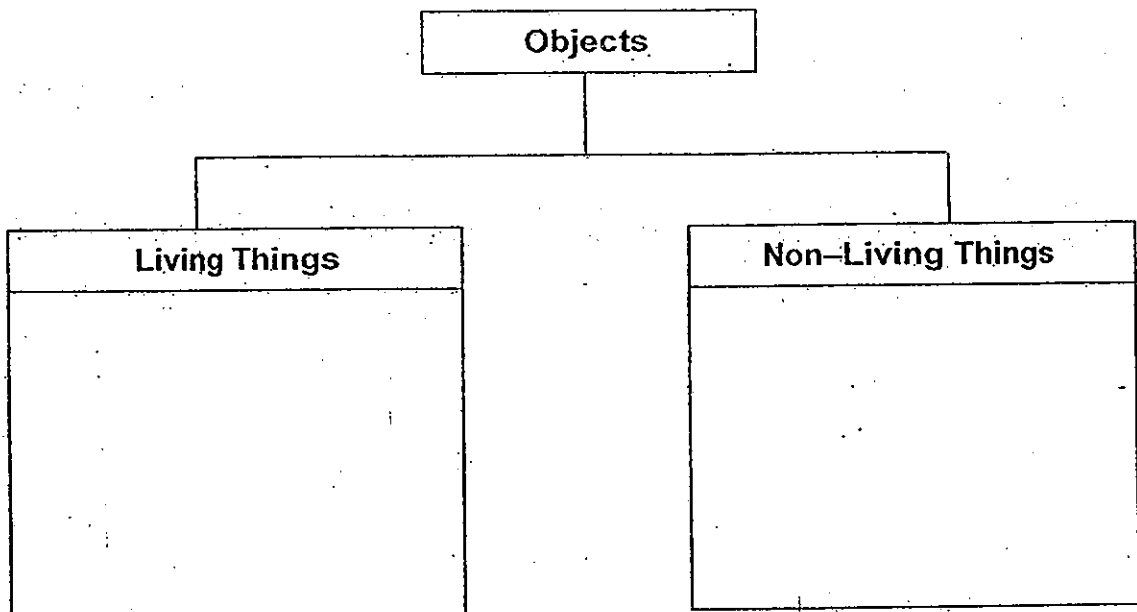

23. Study the flowchart below.

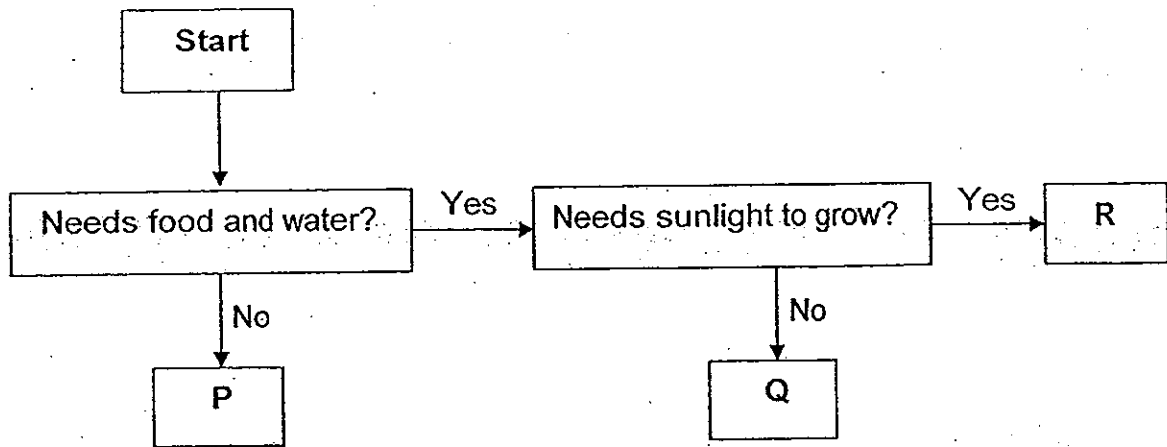

(a) Which of the following are P and R?

|          |       |       |
|----------|-------|-------|
| Kangaroo | Radio | Ixora |
|----------|-------|-------|

P : \_\_\_\_\_ (1m)

R : \_\_\_\_\_ (1m)

(b) Peter studied the flowchart above and identified Sunflower as "Q" as shown below.

Q : Sunflower

Is Peter correct? Explain your answer based on the flow chart above. (1m)

---

---

---

24. (a) Look at the water plants in the pond below.

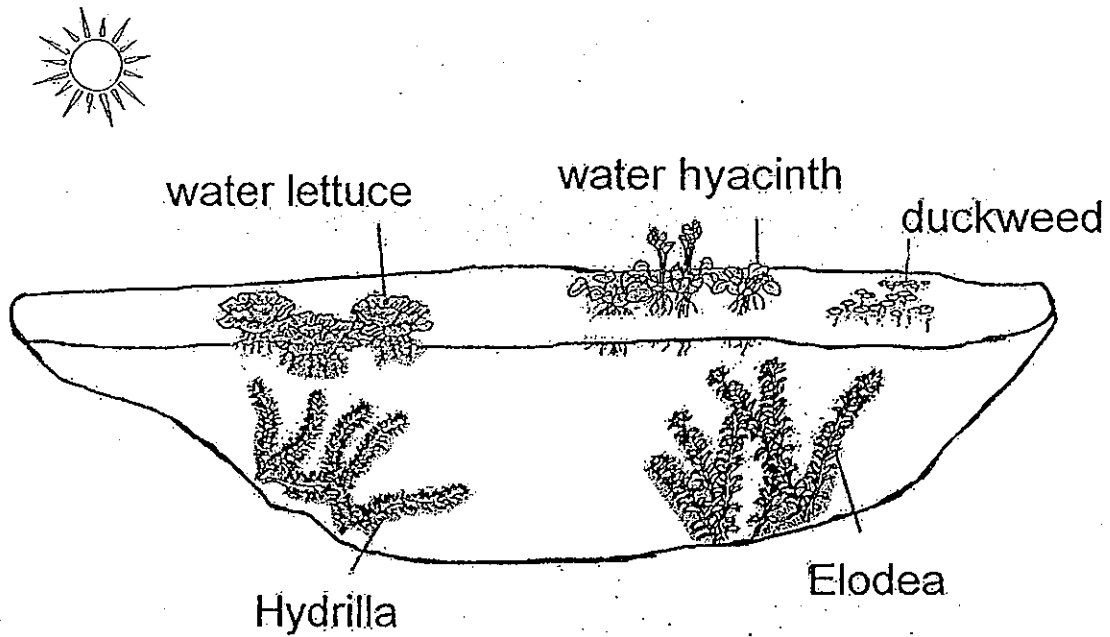

Based on the pond above, circle 'True', 'False' or 'Not Possible To Tell' for the following. (1m)

|       |  |      |       |                      |
|-------|--|------|-------|----------------------|
| (i)   | Water hyacinth is a flowering plant.                           | True | False | Not Possible To Tell |
| (ii)  | The water plants need sunlight to grow.                        | True | False | Not Possible To Tell |
| (iii) | Duckweeds are smaller in size than water lettuce.              | True | False | Not Possible To Tell |
| (iv)  | There are more types of submerged plants than floating plants. | True | False | Not Possible To Tell |

(b) Elodea is a submerged plant. Its leaves trap sunlight to make food, using carbon dioxide and water. Which characteristic of living things is Elodea showing? (2m) ~~(1m)~~

---



---



---

25. Study the flow chart below.

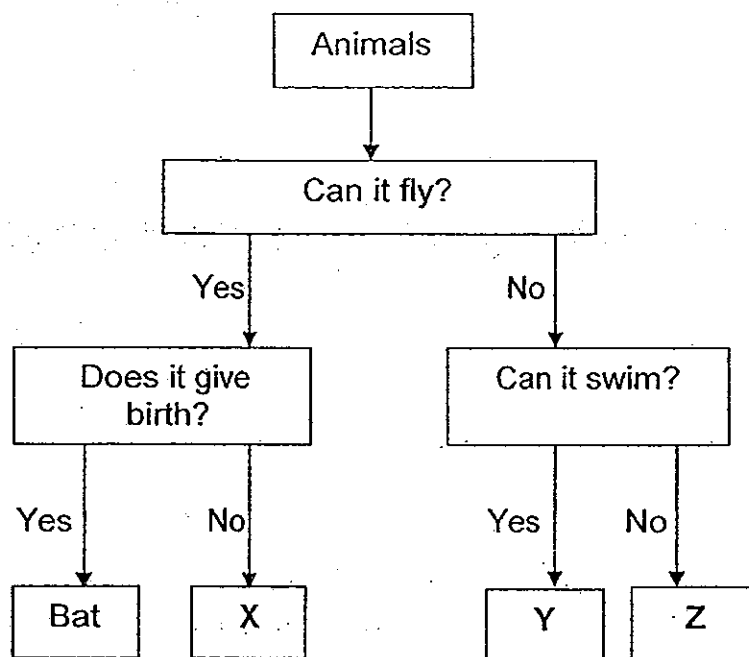

Identify the animals represented by the letters, X, Y and Z, in the flow chart above. Write X, Y or Z in the correct boxes below. (3m)

(a) Emu:

(b) Crow:

(c) Stingray:

26. Study the flowchart below.

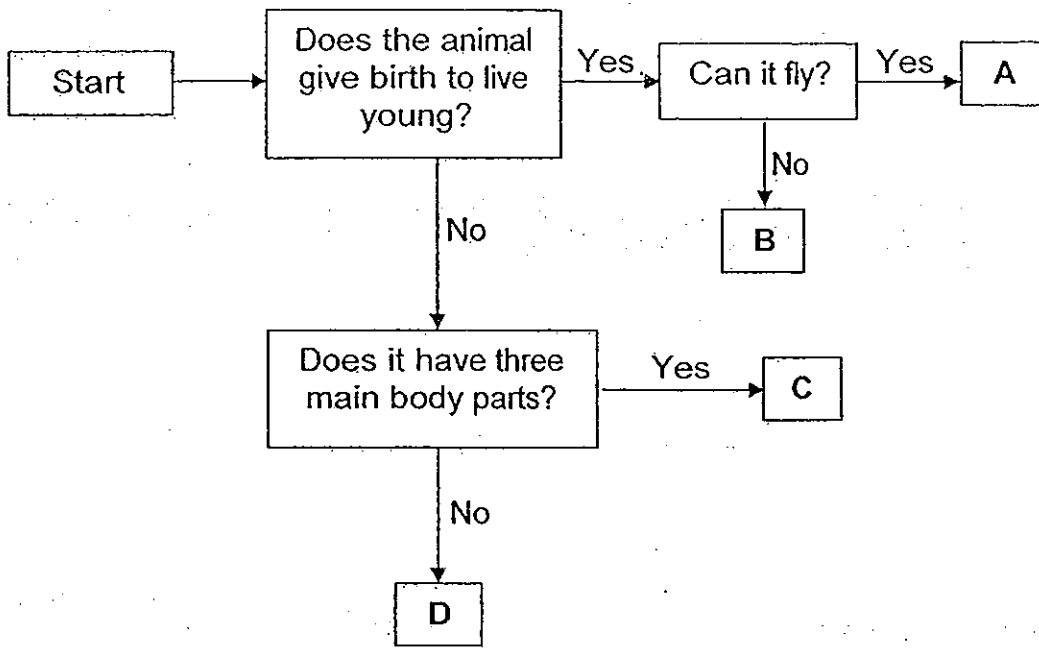

(a) Based on the flowchart above, state the characteristics of the animal, C. (1m)

---

---

---

(b) How are the animals, A and B, similar? (1m)

---

---

---

(c) How are the animals, C and D, different? (1m)

---

---

---



27. The picture below shows a mushroom.

(a) Name the parts of the mushroom labelled A and B.

(2m)

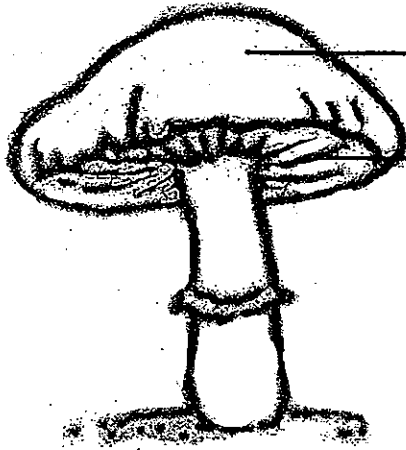

A: \_\_\_\_\_

B: \_\_\_\_\_

(b) How does mushroom reproduce?

(1m)

---

---

28. (a) Classify the materials below under the correct headings of the classification chart provided. (2m)

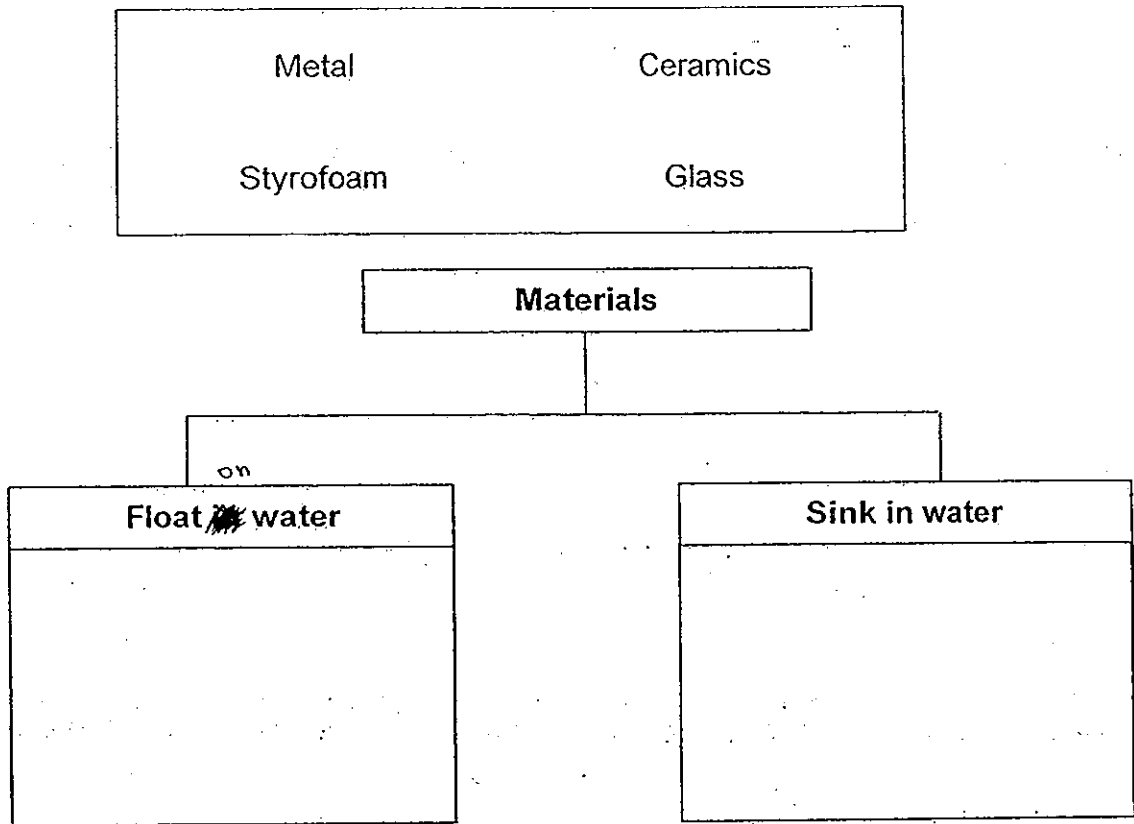

- (b) An anchor is used to keep a ship in one place.

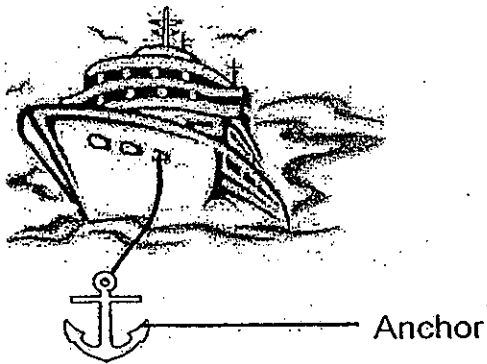

What material is suitable for making the anchor? Give a reason for your \_\_\_\_\_ (1m)

---

---

---

# ANSWER SHEET

**EXAM PAPER 2013**

**SCHOOL : TAO NAN PRIMARY SCHOOL**

**SUBJECT : PRIMARY 3 SCIENCE**

**TERM : SA1**

|    |    |    |    |    |    |    |    |    |     |     |     |     |     |     |     |     |
|----|----|----|----|----|----|----|----|----|-----|-----|-----|-----|-----|-----|-----|-----|
| Q1 | Q2 | Q3 | Q4 | Q5 | Q6 | Q7 | Q8 | Q9 | Q10 | Q11 | Q12 | Q13 | Q14 | Q15 | Q16 | Q17 |
| 3  | 2  | 4  | 4  | 3  | 4  | 4  | 2  | 3  | 3   | 3   | 4   | 3   | 4   | 4   | 2   | 2   |

|     |     |     |
|-----|-----|-----|
| Q18 | Q19 | Q20 |
| 3   | 4   | 2   |

Section B

Q21

a)

| Activities                    | Characteristics |
|-------------------------------|-----------------|
| (1) A bird lays an egg        | C               |
| (2) A frog swims in a pond    | B               |
| (3) A chick grows into a hen  | A               |
| (4) A cheetah feeds on a deer | D               |

b) The mouse died because there was a lack of air

Q22)

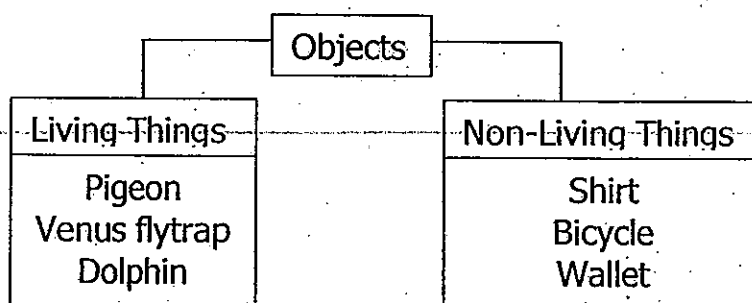

Q23

a) P: Radio ; R: Ixora

b) No, because the Sunflower is a plant and every plant needs sunlight to grow

Q24

a)

|       |  |      |       |                      |
|-------|--|------|-------|----------------------|
| (i)   | Water hyacinth is a flowering plant                  | True | False | Not possible to tell |
| (ii)  | The water plants need sunlight to grow               | True | False | Not possible to tell |
| (iii) | Duckweeds are smaller in size than water lettuce     | True | False | Not possible to tell |
| (iv)  | There are more submerged plants than floating plants | True | False | Not possible to tell |

b) It shows that living things need food, water and air to survive.

Q25

a) Z

b) X

c) Y

Q26

a) Animal C does not give birth to young and have three body parts

b) Both A and B give birth to live young

c) Animal C has three main body parts while D does not have three main body parts

Q27

a) A: Cap; B: Gills

b) The mushroom reproduces by spores

Q28

a)

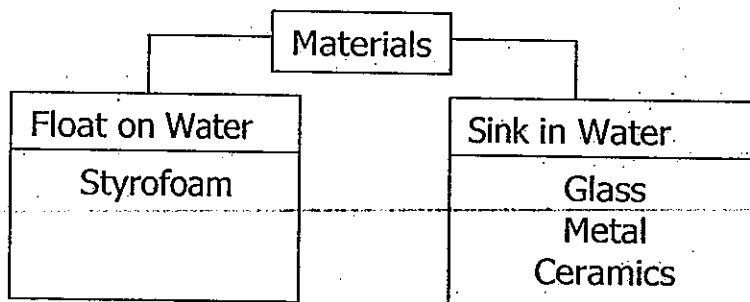

b) Metal. The anchor is heavy